

TOP FLITE™

TOP FLITE™
TUTOR™
III
ARF

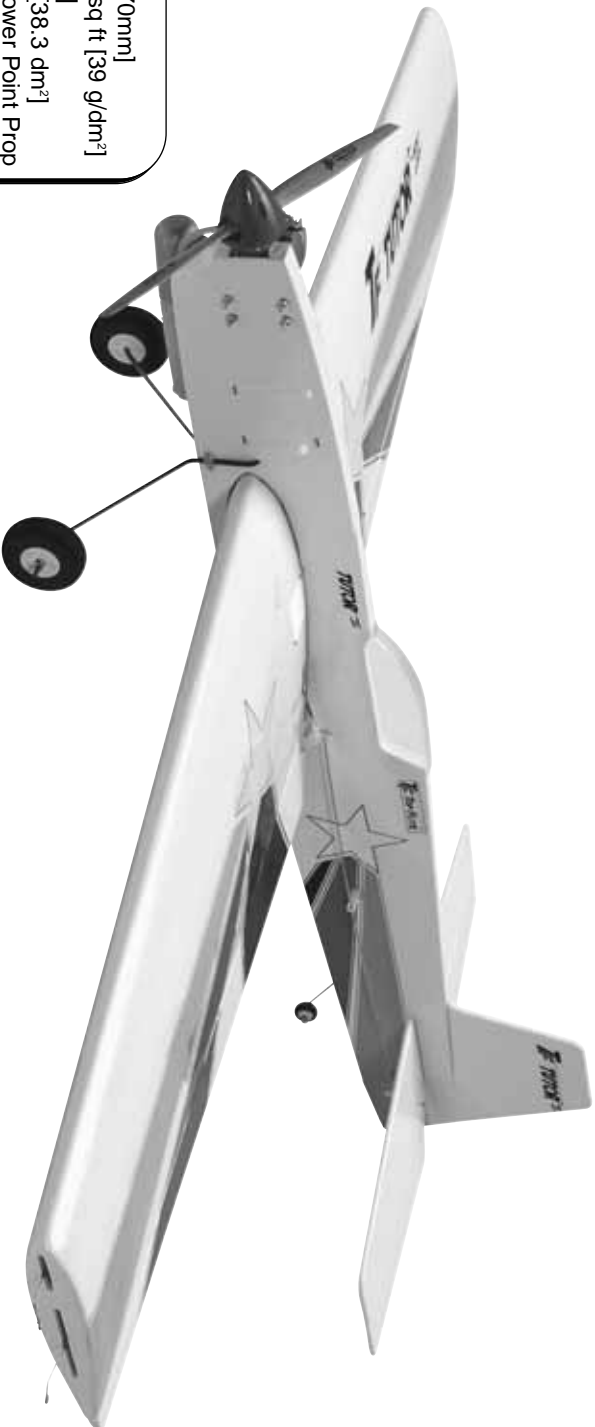

Wingspan: 54 in [1,370mm]
Wing Loading: 13 oz/sq ft [39 g/dm²]
Length: 43 in [980mm]
Wing Area: 594 sq in [38.3 dm²]
Prop: 11x4 Top Flite Power Point Prop
Weight: 3.5 – 4 lb [1,590 – 1,815g]
Engine: .40 – .46 cu in [5.5 – 7.5cc]
2-stroke glow control line

WARRANTY.....**Top Flite**® Models guarantees this kit to be free from defects in both material and workmanship at the date of purchase. This warranty does not cover any component parts damaged by use or modification. **In no case shall Top Flite's liability exceed the original cost of the purchased kit.** Further, Top Flite reserves the right to change or modify this warranty without notice. In that Top Flite has no control over the final assembly or material used for final assembly, no liability shall be assumed nor accepted for any damage resulting from the use by the user of the final user-assembled product. By the act of using the user-assembled product, the user accepts all resulting liability. **If the buyer is not prepared to accept the liability associated with the use of this product, the buyer is advised to return this kit immediately in new and unused condition to the place of purchase.**

Top Flite Models **Champaign, IL**

Telephone (217) 398-8970, Ext. 5

airsupport@top-flite.com

READ THROUGH THIS INSTRUCTION BOOK FIRST. IT CONTAINS IMPORTANT INSTRUCTIONS AND WARNINGS CONCERNING THE ASSEMBLY AND USE OF THIS MODEL.

TABLE OF CONTENTS

INTRODUCTION	2
IMPORTANT SAFETY PRECAUTIONS	2
ENGINE & LINE RECOMMENDATIONS	3
ADDITIONAL ITEMS REQUIRED	3
Hardware & Accessories	3
Adhesives & Building Supplies	3
Optional Supplies & Tools	3
Covering Tools	3
KIT INSPECTION	4
ORDERING REPLACEMENT PARTS	4
IMPORTANT BUILDING NOTES	4
KIT CONTENTS	5
BUILDING INSTRUCTIONS	6
Assemble the Main Wing	6
Install the Horizontal Stab	7
Attach the Elevators	8
Attach the Fin	8
Install the Flaps	9
Connect the Flap Pushrod	9
Connect the Elevator Pushrod	10
LANDING GEAR INSTALLATION	11
Install the Main Gear	11
Install the Tail Gear	12
ENGINE INSTALLATION	12
FUEL TANK INSTALLATION	13
Assemble the Fuel Tank	13
Mount the Fuel Tank	13
FINAL DETAILS	14
Control Surface Check	14
Mount the Canopy	14
Apply the Decals	14
GET THE MODEL READY TO FLY	15
Balance the Model (C.G.)	15
Balance the Propeller	15
Engine Check	15
Control Check	15
Adjustable Leadouts	15
ENGINE SAFETY PRECAUTIONS	16
AMA SAFETY CODE (excerpt)	16
General	16
Control Line	16

CHECK LIST	17
FLYING	17
Preflight	17
Takeoff	18
Landing	18
AMA STUNT MANEUVERS	19

INTRODUCTION

Congratulations and thank you for purchasing the Top Flite Control Line Tutor II ARF. Reincarnated and enlarged from original Top Flite plans, the Tutor II ARF is a perfect way to get into beginner stunt flying without the initial time and money commitment required for today's kit-built stunters. And if you plan to just dabble in control line, the Tutor II ARF has the perfect blend of maneuverability and stability to get you into the air with minimal assistance from an experienced flyer.

PROTECT YOUR MODEL, YOURSELF & OTHERS FOLLOW THESE IMPORTANT SAFETY PRECAUTIONS

1. Your Top Flite Tutor II ARF should not be considered a toy, but rather a working model that functions like a full-size airplane. Because of its performance capabilities, the Tutor II ARF, if not assembled and operated correctly, could possibly cause injury to yourself or spectators and damage to property.
2. You must assemble the model according to the instructions. Do not alter or modify the model, as doing so may result in an unsafe or unflyable model. In a few cases the instructions may differ slightly from the photos. In those instances the written instructions should be considered as correct.
3. You must take time to build straight, true and strong.

4. You must use control lines that are in first-class condition with appropriate length and diameter. Use a correctly sized engine and components throughout the building process.
5. You must correctly install all pushrods and other components so that the model operates correctly on the ground and in the air.
6. You must check the operation of the model before every flight to insure that all equipment is operating and that the model has remained structurally sound.
7. If you are not already an experienced control line pilot, you should fly the model only with the help of a competent, experienced control line pilot.
8. While this kit has been flight tested to exceed normal use, if the plane will be used for extremely high stress flying, such as racing, the modeler is responsible for taking steps to reinforce the high stress points.

Note: We, as the kit manufacturer, provide you with a top quality, thoroughly tested kit and instructions, but ultimately the quality and flyability of your finished model depends on how you build it; therefore, we cannot in any way guarantee the performance of your completed model, and no representations are expressed or implied as to the performance or safety of your completed model.

Remember: Take your time and follow the instructions to end up with a well-built model that is straight and true.

If you have not flown a control line stunt model before, we recommend that you get the assistance of an experienced pilot in your club for your first flights. If you're not a member of a club, your local hobby shop has information about clubs in your area whose membership includes experienced pilots.

In addition to joining a control line club, we strongly recommend you join the AMA (Academy of Model Aeronautics). AMA membership is required to fly at AMA sanctioned clubs. Among other benefits, the AMA provides insurance to its members who fly at sanctioned sites and events. Additionally, training programs and instructors are available at AMA club sites to help you get started the right way. Contact the AMA at the following address or toll-free phone number:

Academy of Model Aeronautics

5151 East Memorial Drive
Muncie, IN 47302-9252
Tele. (800) 435-9262
Fax (765) 741-0057

Or via the Internet at: <http://www.modelaircraft.org>

ENGINE & LINE RECOMMENDATIONS

A .40-.46 [5.5-7.5cc] sized control line engine is required for this plane to achieve its potential. Crisp maneuvers will not be possible with an underpowered engine. Stepping above the recommended engine range may negatively influence the flight characteristics and stability of the Tutor II. Therefore, for maximum enjoyment we recommend staying in the engine range specified.

Also, due to the speed and size of this plane, we recommend flying on 65-70ft [20-22m] lines. Shorter lines will increase the speed at which the pilot turns and maneuvers will have to be executed much more quickly.

ADDITIONAL ITEMS REQUIRED

Hardware & Accessories

Following is a list of hardware and accessories required to finish the Top Flite Control Line Tutor II ARF. Order numbers are provided in parentheses.

- 3' [900mm] Std silicone fuel tubing (GPMQ4131)
- Control lines, .018" x 70' (SULP2636)
- 1/4" [6mm] White striping tape (GPMQ1610)
- Line connectors, Large, 50lb test (SULP2949)
- Standard INSTA JUST handle (SULP2866)

Adhesives & Building Supplies

In addition to common hobby tools and household tools, this is the "short list" of the most important items required to build the Top Flite Tutor II ARF. **Great Planes® Pro™ CA** and **Epoxy** glue are recommended.

- Great Planes 1/2 oz. Thin Pro CA (GPMR6001)
- Great Planes Pro 30-minute epoxy (GPMR6047)
- Great Planes Threadlocker™ thread-locking cement (GPMR6060)
- Hobbico® #1 Hobby knife (HCAR0105)
- Hobbico #1 Blades (5-pack HCAR0211, or 100-pack HCAR0311)
- Drill bits: 1/16" [1.6mm], 5/64" [2mm], 3/32" [2.4mm], 1/8" [3.2mm], 9/64" [3.6mm]
- Small metal file
- Great Planes Stick-on segmented lead weights (GPMQ4485)
- Hobbico Medium T-pins (100, HCAR5150)
- Sandpaper assortment

Optional Supplies & Tools

These are some of the items used while building the Tutor II ARF that are not absolutely necessary, but are mentioned in the manual.

- Top Flite Panel line pen (TOPQ2510)
- Hobbico CA applicator tips (HCAR3780)
- Great Planes CA debonder (GPMR6039)
- Great Planes Pro 6-minute epoxy (GPMR6045)
- Great Planes Epoxy brushes (6, GPMR8060)
- Great Planes Mixing sticks (50, GPMR8055)
- Great Planes Mixing cups (GPMR8056)
- Hobbico Builder's Triangle Set (HCAR0480)
- Hobbico Curved-tip canopy scissors for trimming plastic parts (HCAR0667)
- Denatured alcohol (for epoxy clean up)
- Bulk Kevlar cable 30' [9m] (SULQ3223)
- Great Planes CG Machine™ (GPMR2400)
- Top Flite Precision Magnetic Prop Balancer™ (TOPQ5700)
- Rotary Tool such as Dremel®
- Great Planes Double-sided Servo Tape 1" x 3' [25x915mm] (GPMQ4442)

Covering Tools

- 21st Century® (COVR2700) or Top Flite Monokote® sealing iron (TOPR2100)
- 21st Century (COVR2702) or Top Flite Hot Sock™ iron cover (TOPR2175)

KIT INSPECTION

Before starting to build, take an inventory of this kit to make sure it is complete, and inspect the parts to make sure they are of acceptable quality. If any parts are missing or are not of acceptable quality, or if you need assistance with assembly, contact **Product Support**. When reporting defective or missing parts, use the part names exactly as they are written in the Kit Contents list on page 5.

Great Planes Product Support

3002 N Apollo Drive Suite 1

Champaign, IL 61822

Telephone: (217) 398-8970

Fax: (217) 398-7721

E-mail: airsupport@top-flight.com

ORDERING REPLACEMENT PARTS

Replacement parts are not available from Product Support, but can be purchased from hobby shops or mail order/Internet order firms. Hardware items (screws, nuts, bolts) are also available from these outlets. If you need assistance locating a dealer to purchase parts, visit www.greatplanes.com and click on "Where to Buy." If this kit is missing parts, contact Product Support.

Note: Full-size plans are not available for the Tutor II ARF.

IMPORTANT BUILDING NOTES

- There are two types of screws used in this kit: **Sheet metal screws** are designated by a number and a length.

For example #6 x 3/4" long [19mm]

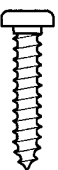

This is a number six screw that is 3/4" [19mm] long.

- **Machine screws** are designated by a number, threads per inch, and a length.

For example 4-40 x 3/4" long [19mm]

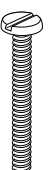

This is a number four screw that is 3/4" [19.1mm] long with forty threads per inch.

- When you see the term **test fit** in the instructions, it means that you should first position the part on the assembly **without using any glue**, then slightly modify or *custom fit* the part as necessary for the best fit.

- Whenever the term **glue** is written you should rely upon your experience to decide what type of glue to use. When a specific type of adhesive works best for that step, the instructions will tell you what glue is recommended.

- Whenever just **epoxy** is specified, you may use **either** 30-minute (or 45-minute) epoxy **or** (or optional) 6-minute epoxy. When 30-minute epoxy is **specified**, it is **highly recommended** that you use only 30-minute (or 45-minute) epoxy because you will need the working time and/or the additional strength.

- **Photos and sketches** are placed **before** the step they refer to. Frequently you can study photos in following steps to get another view of the same parts.

Note: The stabilizer and wing incidences and engine thrust angles have been factory-built into this model. However, some technically-minded modelers may wish to check these measurements anyway. To view this information, visit the web site at www.top-flight.com and click on "Technical Data." Due to manufacturing tolerances which will have little or no effect on the way the model will fly, there may be slight deviations between your model and the published values.

KIT CONTENTS

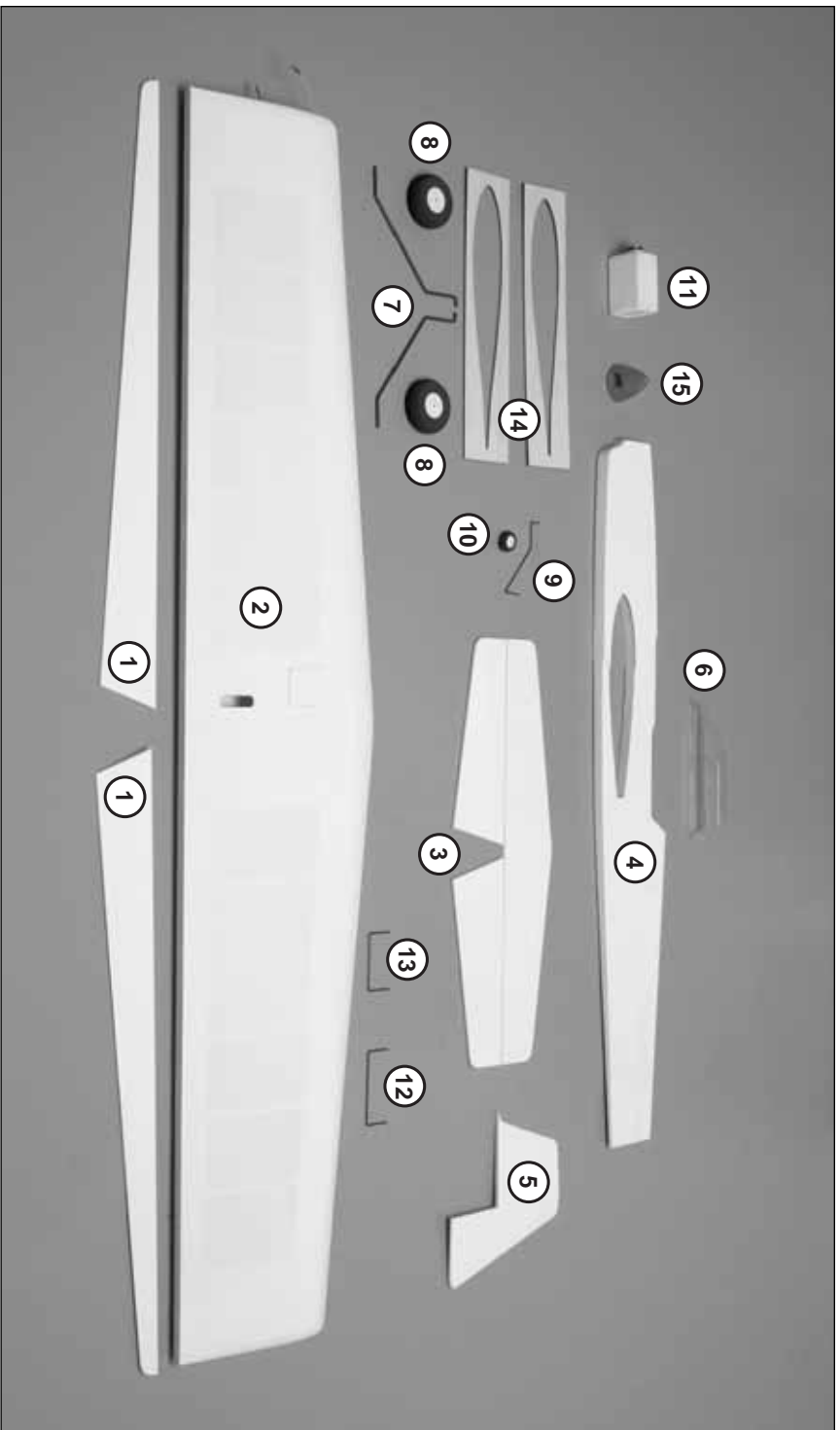

PARTS PHOTOGRAPHED

1. Flaps
2. Wing
3. Horizontal Stabilizer with Elevators
4. Fuselage
5. Fin
6. Canopy
7. Main Landing Gear (2)
8. 2-1/2" [65mm] Main Wheels (2)
9. Tail Gear Wire
10. Tail Wheel
11. Fuel Tank
12. Flap Joiner Wire
13. Elevator Joiner Wire
14. 1/8" [3mm] Plywood Flap
15. Spinner

PARTS NOT PHOTOGRAPHED

- (2) Nylon Tie Straps
- (1) 2-56 x 18" [458mm] Pushrod (Elevator)
- (1) 2-56 x 6" [153mm] Pushrod (Flaps)
- (2) Nylon Clevises
- (6) 4-40 x 1-1/2" [38mm] Socket Head Cap Screws (2-Main Gear, 4-Engine Mounting)
- (6) 4-40 Nylon Lock Nuts (2-Main Gear, 4-Engine Mounting)

- (8) #4 Flat Washers (Gear Mounting)
- (4) 5-32" [4mm] Wheel Collars (Main Wheels)
- (1) 5-64" [2mm] Wheel Collar (Tail Wheel)
- (5) 6-32 Set Screws (Wheel Collars)
- (1) #2 x 1/2" [13mm] Screw (Pushrod Standoff)
- (2) #2 x 3/4" [19mm] Machine Threaded Screws (Flap Control Horn)
- (2) #2 x 1/2" [13mm] Machine Threaded Screws (Elevator Control Horn)
- (4) #2 x 1/4" [6mm] Screws (Hatch on Wing)

- (2) #2 x 5/8" [16mm] Screws (Tail Gear)
- (2) Nylon Hump Straps
- (1) Nylon Flat Strap
- (1) Hinge Strip Material
- (2) Silicone Clevis Retainers
- (1) Bell Crank with Leadouts (Factory Installed)
- (1) Metal Pushrod Standoff
- (2) Large Nylon Control Horns with Backplates
- (2) Decal Sheet

BUILDING INSTRUCTIONS

Assemble the Main Wing

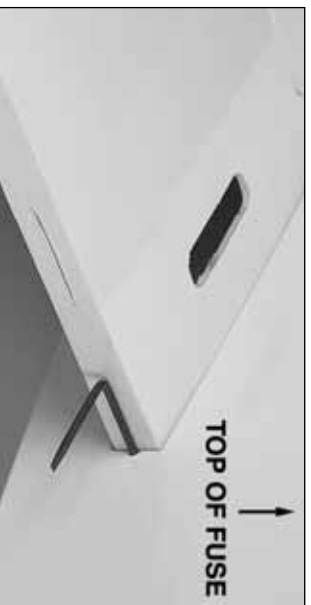

- ❑ 1. Locate the 4" [102mm] Flap Joiner Wire. There is a notch in the trailing edge (TE) of the wing saddle where this wire will rest. Slide the wing in place while holding this joiner as shown above. **Be sure the hatch in the wing is on the top.**

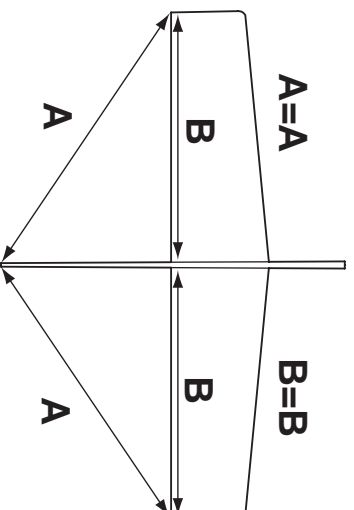
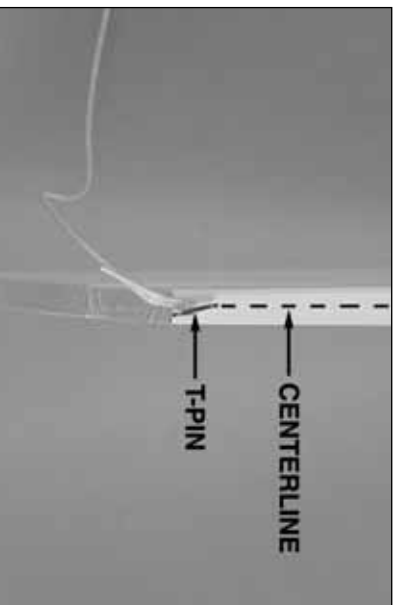

- ❑ 2. Center the wing laterally (B=B). Insert a **T-pin** through the top, center of the fuselage over the tail. Tie a loop in one end of a 36" [1m] piece of non-elastic string such as monofilament or Kevlar cable (SULQ3223). Slip the loop in the string over the T-pin.

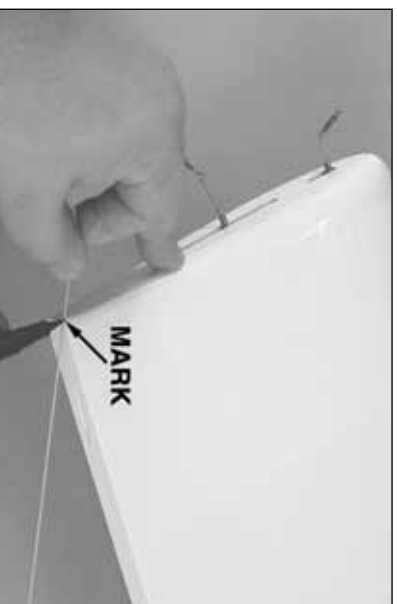

- ❑ 3. Fold a piece of masking tape over the string near the other end and draw an arrow on it or mark the string with a black marker. Slide the tape along the string and align the arrow with one end of the wing as shown in the sketch, or make a mark where the string crosses the wing. Swing the string over to the other end of the wing and hold it in the same position. Keeping the trailing edge of the wing centered from side-to-side, move the wing tips forward or back as necessary until the arrow, or mark aligns with both ends of the wing.



- ❑ 4. Once the wing is aligned, use a fine point marker such as a Top Fite Panel Line Pen to trace around the wing. Remove the wing and joiner from the fuselage.



- ❑ 5. Remove the covering using a sharp, new hobby knife or a heated soldering iron to cut the covering from the wing 1/16" [1.6mm] inside the lines. If using a knife, use a light touch and great care not to cut into the sheeting under the covering or the wing will be weakened. Using a soldering iron is preferred because it melts through the covering without cutting into the wood. Move the soldering iron fast enough to melt through the covering without burning the wood. After cutting the covering, use denatured alcohol and a tissue to clean the ink lines from the covering. Then, peel off the covering.

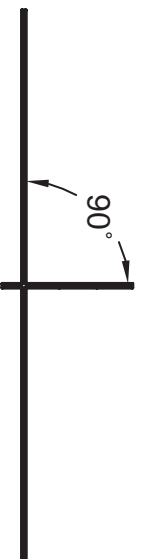

- ❑ 6. Mix up a batch of 30-minute epoxy. Slide the wing most of the way into the fuselage. Apply epoxy to the inside of the wing saddle and to the wing where it contacts the fuselage. Slide the wing into position with the joiner wire. **Be careful not to let epoxy come in contact with the flap joiner wire. If you are uncertain about the flap joiner wire, you can coat the center of the wire with petroleum jelly to prevent the epoxy from securing it in place.** Verify the alignment of the wing as done in step 3. Ensure the wing remains perpendicular to the fuselage as shown in the sketch. Use small balsa sticks and/or paper towels and alcohol to wipe up excess epoxy. Allow the epoxy to fully harden before proceeding.

Install the Horizontal Stabilizer

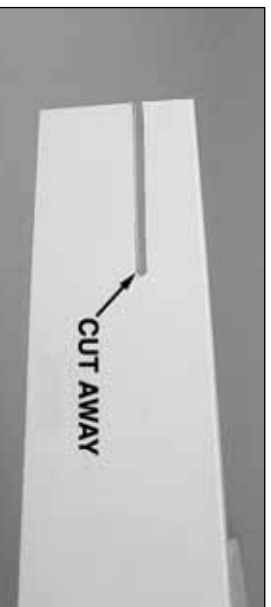

- ❑ 1. Remove the covering from the stab slot using a sharp hobby knife.

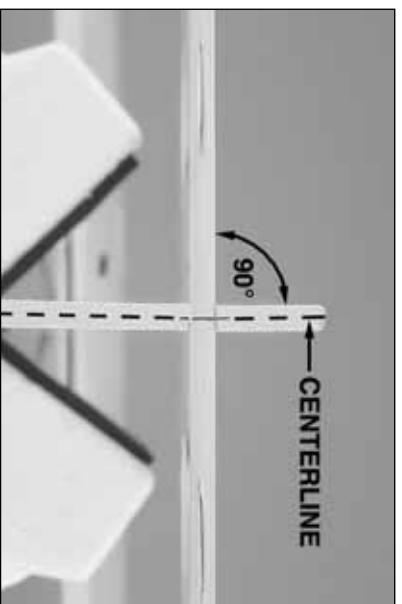
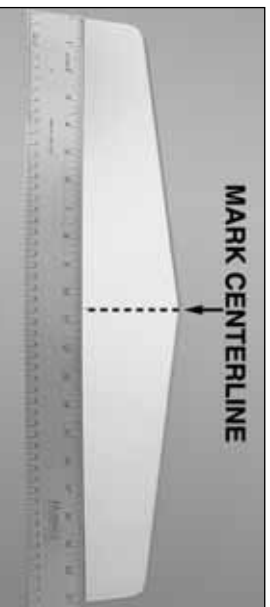

- ❑ 2. Measure and mark the centerline of the TE of the stab. Also mark a spot on the centerline on the aft end of the fuse. Test fit the stab aligning the marks you just made.

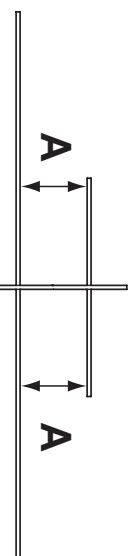

- ❑ 3. Slide the stab into position. For now, center the stab in the fuselage as best as you can by "eye." Stand approximately ten feet behind the model and view the alignment of the stab and wing. If the stab is not parallel with the wing, place a small weight on the "high side" of the stab to bring it into alignment. If weight is not enough, remove the stab from the fuselage and lightly trim or sand the stab saddle as necessary until you can get the stab to align with the wing.

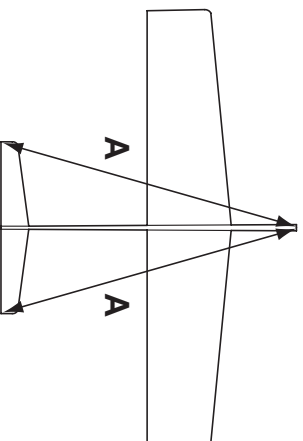

- ❑ 4. Now that the stab is level with the wing, center the trailing edge of the stab in the fuselage by measuring

from both tips to the center of the fuselage. Make sure "A" = "A" on both sides of the stab as indicated in the sketch. Stick pins into the stab near the trailing edge on both sides of the fuselage. This will keep the trailing edge of the stab centered.

- ❑ 5. Insert a pin through the top, center of the fuselage on the nose of the fuselage. Tie a loop in one end of a 36" [920mm] piece of non-elastic string such as monofilament or Kevlar cable (SULQ3223). Slip the loop in the string over the T-pin.

- ❑ 6. Fold a piece of masking tape over the string near the other end and draw an arrow on it or mark the string with a black marker. Slide the tape along the string and align the arrow with one end of the stab as shown in the sketch, or make a mark where the string crosses the stab. Swing the string over to the other end of the stab and hold it in the same position. Keeping the trailing edge of the stab centered from side-to-side, move the wing tips forward or back as necessary until the arrow, or mark, aligns with both ends of the stab.

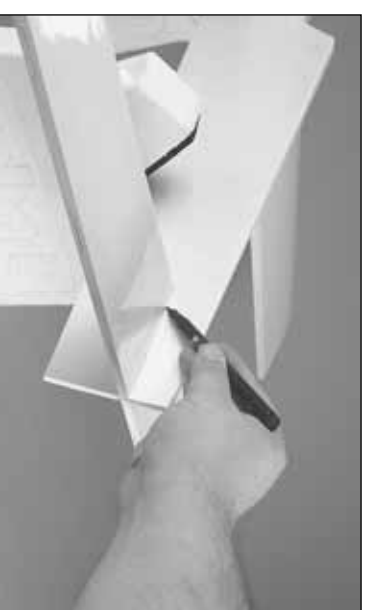

- ❑ 7. The same as was done for the wing, use a fine-point felt-tip pen to mark the outline of the fuselage all the way around both sides of the stab. Then, cut and remove the covering from the center-section.

- ❑ 8. Mix up a small batch of 30 minute epoxy and coat the areas that you removed covering from on the stab. Slide the stab into the mounting slot. Clean up excess epoxy with a paper towel and alcohol. Be sure to check the alignment PRIOR to the epoxy hardening.

Attach the Elevators

- ❑ 1. Locate the **Elevator Joiner Wire** and the two elevator halves.

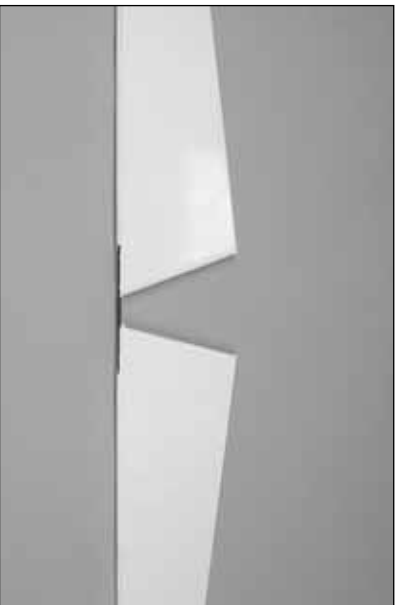

- ❑ 2. Remove the covering from the precut groove in the LE of the elevator halves. Test fit the joiner wire in both elevator halves. The elevator halves should both lay flat with the joiner installed. If they do not, you may “tweak” the wire to get both halves to lay flat when joined.

- ❑ 3. Use a piece of wire or a toothpick to apply epoxy in the holes and grooves in the elevators for the joiner wire. Insert the joiner wire into both elevators. Wipe away excess epoxy as it squeezes out.

- ❑ 4. Insert 3 hinges into each elevator half and install the elevator assembly on the stab. Insert T-pins into the center of each hinge to keep them centered.



- ❑ 5. Using thin CA, glue each hinge in place. Apply 6 drops of CA on each hinge, top and bottom. After the glue has cured, pull on the elevator halves to be sure the hinges are glued securely in place. Apply more CA if necessary.

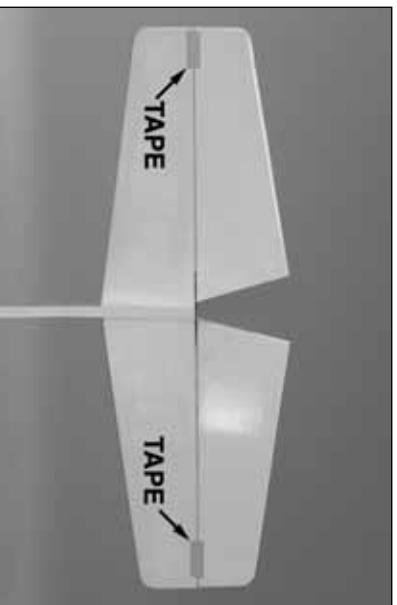

- ❑ 6. Using masking tape, hold the elevators in place ensuring they remain parallel to each other when viewed from behind.

- ❑ 7. Allow the epoxy to fully harden on the elevator halves before proceeding.

Attach the Fin

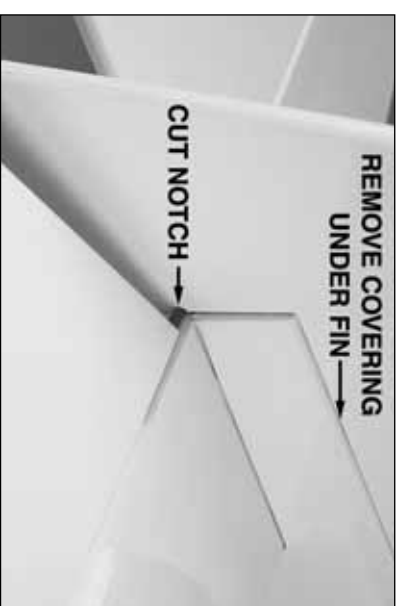

- ❑ 1. Test fit the **fin**. Make note of where the elevator joiner wire comes in contact with the fin. You will need to make a small notch to allow the elevator joiner wire to rotate freely at this location and allow the fin to rest flush against the fuselage for gluing. Remove the fin and coat the notch with thin CA to fuelproof the exposed wood.

- ❑ 2. Check where the fin contacts the fuselage once you have it aligned. Mark the outline of the fin on the fuselage and remove the covering between these marks.

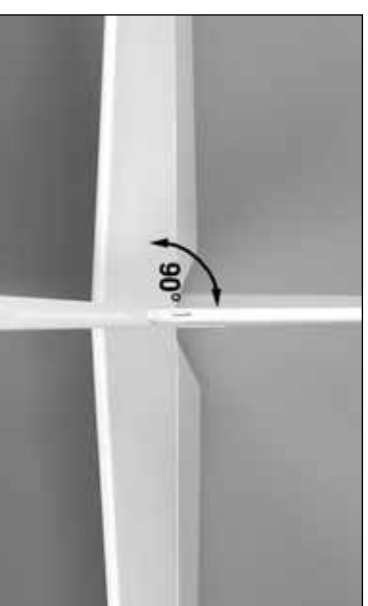

- ❑ 3. Glue the fin in place as shown using 30 minute epoxy. The leading edge of the fin should be centered on the fuselage. Ensure the fin is perpendicular (at a 90° angle) to the horizontal stabilizer. Use T-Pins and masking tape to hold the fin in place until the epoxy fully hardens.

Install the Flaps

- ❑ 1. Without using any glue, test fit the flap to the joiner wire and install 4 hinges. If necessary, use a hobby knife to enlarge any hinge slots that are too tight.

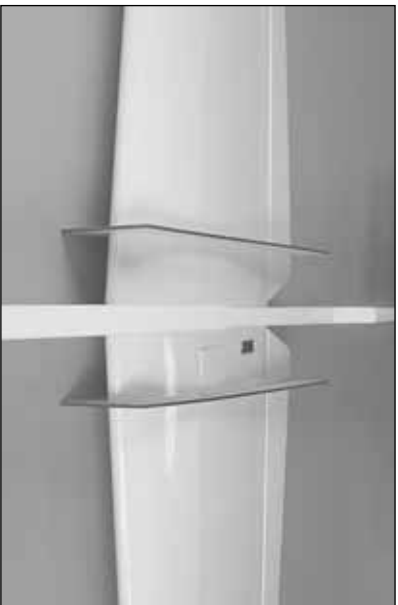

- ❑ 2. Remove the flaps. Mix up a small batch of 30 minute epoxy. Use a piece of wire or a toothpick to apply epoxy in the hole and groove in the flap for the joiner wire. Join the flaps to the wing with the joiner wire and hinges. Slide the **1/8" [3mm] Die-Cut Ply Flap Aligning Jig** over the wing and flap until it is snug and no gaps are present. Do this for both wing halves. Once they are in place, the aircraft can rest on these jigs.
- ❑ 3. Once the epoxy has fully hardened, remove the jigs and apply thin CA to the hinges. Do not use accelerator.

- ❑ 4. View the trailing edges of the flaps from the end of the wing. See if the flaps are parallel with each other (have the same "up" and "down"). If necessary, carefully "tweak" the joiner wire to align the flaps.

Connect the Flap Pushrod



- ❑ 1. Remove the hatch on the left wing panel so you can see the bellcrank below.
- ❑ 2. Locate the **6" [152mm] 2-56 pre-bent flap pushrod**. Thread a **nylon clevis** approximately 14 turns onto the threaded portion. Slide a silicone clevis retainer onto the clevis as shown.

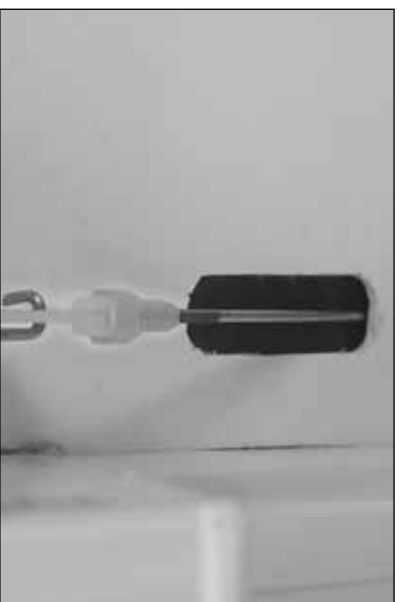

- ❑ 3. Slide the pushrod through the slot provided in the wing. It should exit in the center of this slot.



- ❑ 4. Insert the bent portion of the pushrod into the last hole on the bell crank as shown.

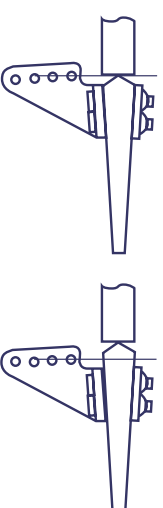

Correct

Incorrect

- ❑ 5. Align the control horn holes with the hinge line. Mark the location of the holes in the base of the control horn. Drill 1/16" [1.6mm] holes at these marks. Attach the control horn and base using **two #2 x 3/4" [19mm] machine threaded screws**.

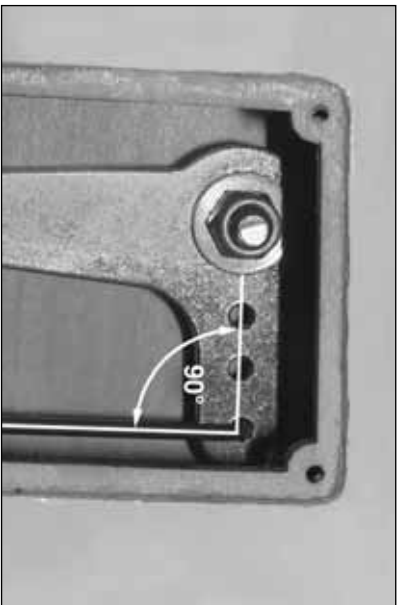
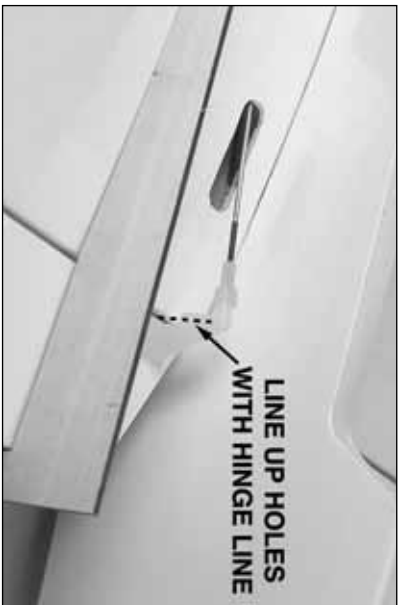

- ❑ 6. Adjust the clevis on the flap pushrod so the flaps will be centered when the bell crank is neutral.

Hint: The jigs you used to align the flaps can also be used here to position the flaps at center and hold them there while you adjust the flap pushrod. Connect the clevis to the top hole in the control horn. Slip the retainer over the clevis.

Connect the Elevator Pushrod

- ❑ 1. Locate the **18" [460mm] 2-56 pre-bent elevator pushrod wire**.

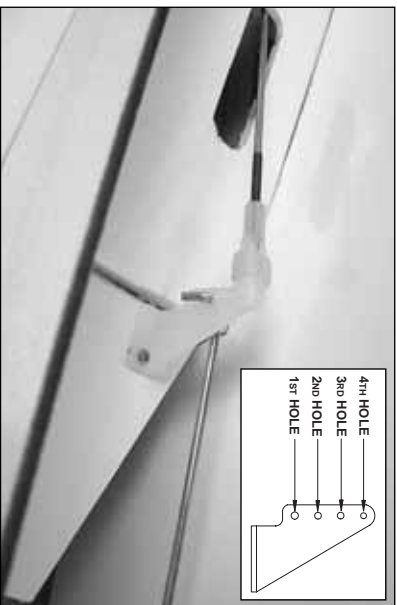

- ❑ 2. Insert the bend end into the second hole on the flap control horn as shown.



- ❑ 3. Locate the **white metal standoff** and slide it over the elevator pushrod. On the fuselage you will notice a darker square showing through the covering. In the center of this block, drill a 3/64" [1.2mm] pilot hole. Be careful not to go all the way through the fuselage. Attach the metal standoff to the fuselage using **one #2 x 1/2" [13mm] self-tapping screw**.

- ❑ 4. Thread a nylon clevis and silicone retainer onto the threaded portion of the pushrod.

- ❑ 5. Align the elevator control horn holes with the hinge line as you did with the flap control horn. Mark the location of the holes in the base of the control horn on the elevator. Drill 1/16" [1.6mm] holes at these marks. Attach the control horn and base using **two #2 x 1/2" [13mm] machine threaded screws**.

- ❑ 6. Adjust the clevis on the elevator pushrod so the elevators will be centered when the bell crank is neutral. Connect the clevis to the 3rd hole in the control horn. Slip the retainer over the clevis.

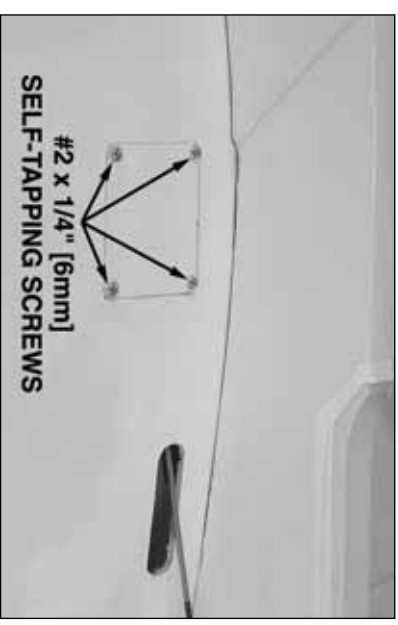

- ❑ 7. Use four #2 x 1/4" [6mm] self-tapping screws to attach the hatch to the opening above the bellcrank in the wing. Remove the screws and harden the holes with thin CA. Allow the glue to dry completely before reinstalling the hatch.

LANDING GEAR INSTALLATION

Install the Main Gear

- 1. Locate the 5/32" [4mm] landing gear wire.

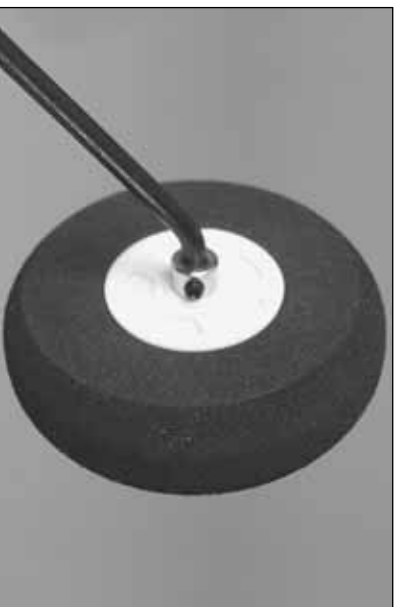

- 2. Slide a 5/32" [4mm] wheel collar over the axle, followed by a 2-1/2" [65mm] main wheel, then another wheel collar. Insert a 6-32 set screw into each wheel collar and tighten to attach the wheel as shown.



- 3. Remove the wheel and wheel collars and using a rotary tool such as a Dremel®, grind flat spots on the axle where the set screws will rest.

- 4. Reassemble the gear, using Threadlocker on the set screws to prevent them from backing out. Add a drop of oil to the axle to ensure the wheel spins freely.



- 5. Locate the two 5/32" [4mm] holes on each side of the fuselage just forward of the main wing and remove the covering using a sharp hobby knife.

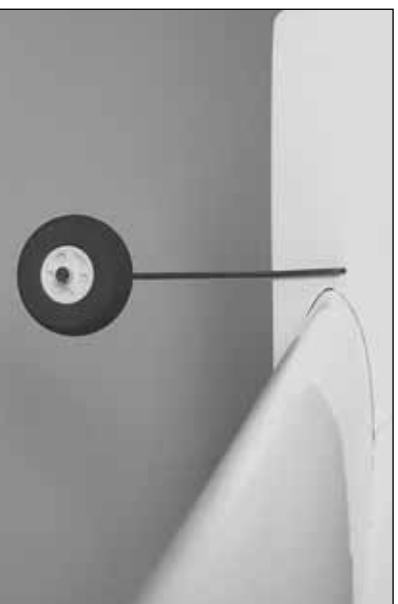

- 6. Insert one of the gear legs as shown in the hole. The gear should point straight down. Note: due to wood possibly compressing or expanding during shipment, you may have to widen the hole slightly to allow the gear to seat fully.



- 7. Position one nylon humped landing gear bracket at the midpoint of the gear leg. Mark the holes on the fuselage you will need to drill.

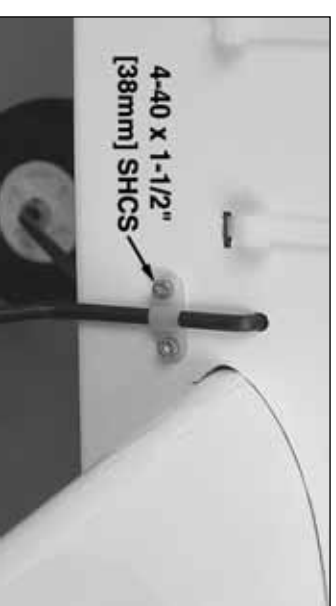

- 8. Drill two 1/8" [3mm] holes at these marks all the way through the fuselage. Wick some thin CA into the holes to harden them. Attach the strap to the fuselage using two 4-40 x 1-1/2" [38mm] socket head cap screws. On the other side of the fuselage, slide the landing gear strap over the two socket head cap screws and attach two 4-40 nylon locknuts to the ends of the screws. Tighten the screws down to hold the gear in place. Be careful not to over tighten.

Install the Tail Gear

- ❑ 1. Locate the 5/64" [2mm] tailgear wire and the small wheel collar.



- ❑ 2. Mount the tail wheel to the pre-bent tail gear wire with the small wheel collar and a 6-32 set screw. Use Threadlocker on the set screw before installing it into the collar.

- ❑ 3. Drill a 5/64" [2mm] hole at the position shown in the photo 6" [153mm] from the fuselage tail and 1/2" [13mm] from the bottom of the fuselage.

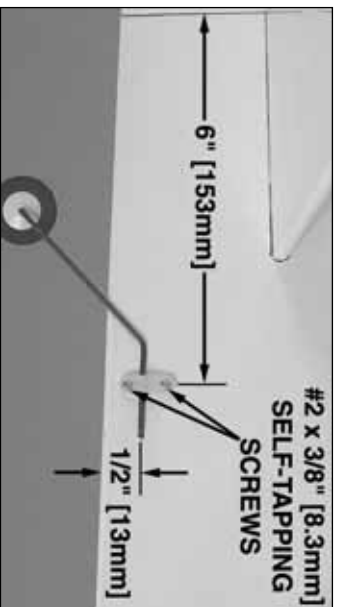

- ❑ 4. Insert the tail gear wire as shown into the hole. It may be necessary to trim the wire so it does not come out the other side of the fuselage. Mix a small batch of 30-minute epoxy and fill the hole for the tail gear wire with epoxy and hold the tail wire in place with tape while the epoxy hardens. Locate the nylon gear strap. Secure the tail wire to the fuselage using the nylon gear strap and two #2 x 5/8" [16mm] self-tapping screws. Remove the screws and harden the holes with thin CA. Allow the CA to harden completely before re-installing the screws.

ENGINE INSTALLATION



- ❑ 1. Our test models were flown using the O.S. .40 and .46 LA C/L engines. If you choose to use another brand of engine, you will need to test fit the engine and mark the location of the engine mounting holes. Be sure the front of the thrust washer clears the fuselage. The engine mounting rails may need to be sanded to accommodate other brands of engines.

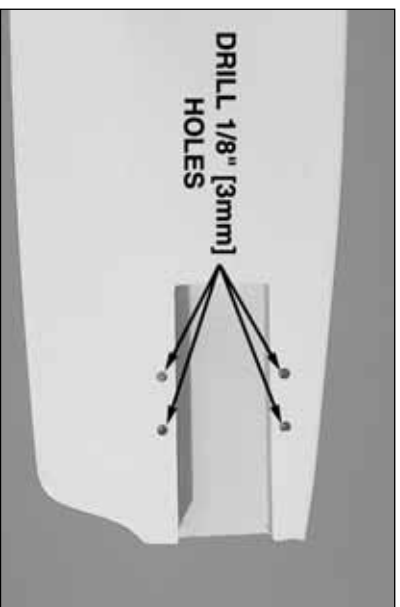

- ❑ 2. If you are using an O.S. engine, the engine mounting bolt holes have been started for you as a guide. Locate the four holes on each side of the fuselage by lightly rubbing the covering with your finger and feeling for the holes. Use a T-pin to poke the covering to verify you have found the hole. Remove the covering from the hole using a sharp

hobby knife. Drill 1/8" [3mm] holes through the engine mounting rails at the marks for your engine to allow the engine mounting bolts to pass through. Laying a small block of wood on the back side of the fuselage when drilling will help prevent the wood from splintering. Strengthen these holes by wicking some thin CA into them.



- ❑ 3. Using four 4-40 x 1-1/2" [38mm] socket head cap screws, 4-40 nylon lock nuts, and eight #4 washers, mount the engine to the fuselage.

FUEL TANK INSTALLATION

Assemble the Fuel Tank



- ❑ 1. Remove the **rubber stopper** from the fuel tank. The hardware for the fuel tank is located inside of it. Shake the fuel tank lightly to get the hardware out. Inside there is a **fuel clunk**, **three aluminum tubes**, and a **3" [76mm] length of silicone fuel tubing**. **NOTE:** You will only use two of the metal tubes for the control line fuel tank setup.

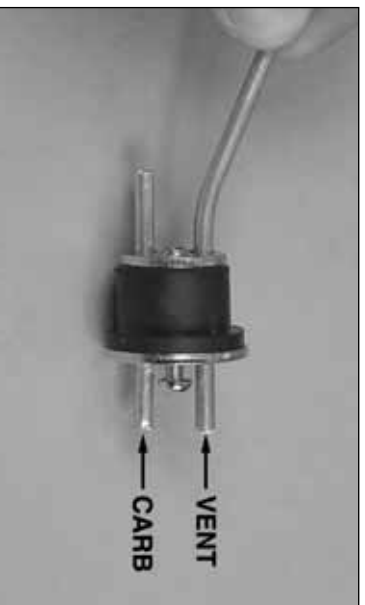

- ❑ 2. Insert two metal tubes through the openings in the stopper assembly as shown. Be sure that the bottom plate is on the stopper assembly when you insert the tubes. Bend one of the tubes slightly. All tubes except for the long bent tube should protrude from the stopper 1/2" [13mm]. The long end does not need to be any specific length.

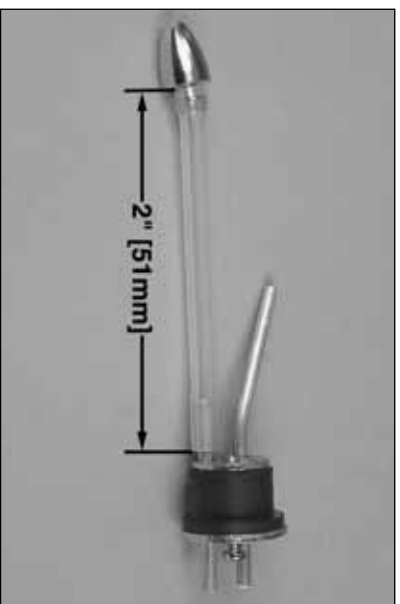

- ❑ 3. Cut the silicone fuel tubing to 2" [51mm] in length and attach the **fuel clunk**.

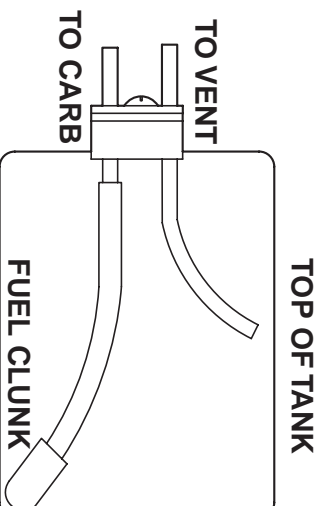

- ❑ 4. Slide the stopper assembly into the **fuel tank**. The bent tube should point upward. The clunk should move freely, but rest against the back of the tank when the stopper is in place. Make note of which of the tubes is bent inside the tank. This will be your **vent line** that is connected to the muffler. The other line is connected to the carburetor on the engine.

Mount the Fuel Tank



- ❑ 1. Locate the four mounting slots for the fuel tank. Remove the covering from these slots with a sharp hobby knife. Wick some thin CA into the slots to fuelproof the exposed wood.



- ❑ 2. Using the two **nylon tie straps** provided, attach the fuel tank to the fuselage. The vent line should be towards the top of the fuselage. **Hint:** A small strip of **double-sided foam tape** could be used between the fuselage and the fuel tank to help hold the fuel tank in place.



- ❑ 3. Cut 4" [102mm] and 3" [77mm] lengths of fuel tubing. Connect the shorter length to the carburetor and the fuel line. The longer piece connects the vent line to the muffler which can now be mounted.

FINAL DETAILS

Prop Installation and Control Surface Check



- ❑ 1. Attach the prop and spinner to the engine.



CONTROL SURFACES AT NEUTRAL

- ❑ 2. Be certain that the flaps are centered when the elevators are centered. Also be certain that all the pushrods are connected and that the flaps and elevator are operating smoothly. Make any adjustments necessary.

Mount the Canopy

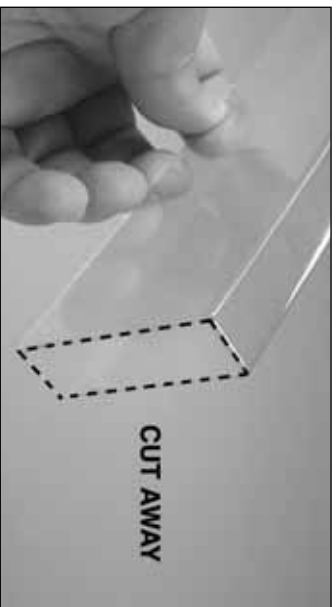

CUT AWAY

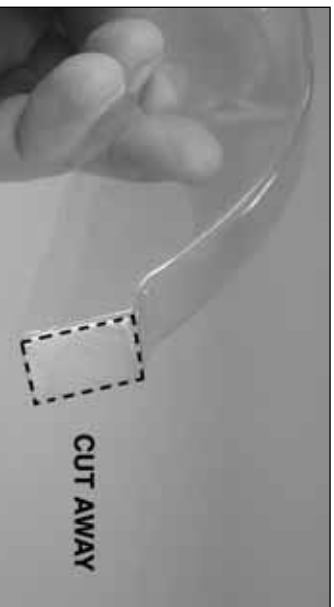

CUT AWAY

- ❑ 1. Use scissors to cut out the **canopy** front and rear.

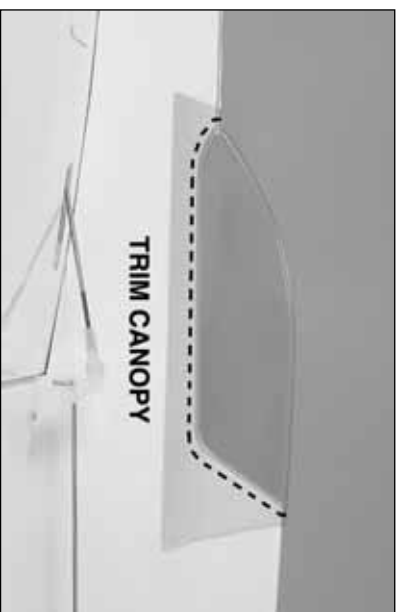

TRIM CANOPY

- ❑ 2. Test fit the canopy and trim it to the desired shape. Be sure to leave enough overlap for the next step.
- ❑ 3. Mount the canopy to the fuselage with **1/4" [6mm] white striping tape** or **Canopy Glue**. Do not use CA as it will attack the clear canopy, causing it to fog over and become soft.

Apply the Decals

Prior to applying decals, use a covering iron with a covering sock to remove any wrinkles in the covering on the wing and flaps. The best way is to glide the iron over the covering until the wrinkles disappear, and then go over the area again, pushing down to bond the covering to the wood. If the wrinkles don't go away, the balsa in that area may be bending inward. If this is happening, do not press down on the iron in that area. Simply let the heat of the iron shrink the covering. If the wrinkles momentarily disappear, then immediately reappear, the iron may be too hot, thus causing air bubbles. Lower the temperature of the iron or use a sharp #11 blade to puncture several holes in the covering, and then reheat. The suggested iron temperature is around 360° F

- ❑ 1. Use scissors or a sharp hobby knife to cut the decals from the decal sheet. Where possible, round the corners so they are less likely to peel up during cleaning and handling.

- ❑ 2. Be certain the model is clean. Prepare a dishpan or small bucket with a mixture of liquid dish soap and warm water—about 1/2 teaspoon of soap per gallon of water. Submerge one of the decals in the solution and peel off the paper backing. Note: Even though the decals have a “sticky-back” and are not the water transfer type, submersing them in soap and water allows accurate positioning and reduces air bubbles underneath.
- ❑ 3. Position the decal on the model where desired. Holding the decal down, use a paper towel to wipe away most of the water.
- ❑ 4. Use a piece of soft balsa or something similar to squeeze remaining water from under the decal. Apply the rest of the decals the same way.

GET THE MODEL READY TO FLY

Balance the Model (C.G.)

At this stage the model should be completely ready-to-fly with all of the components installed including the engine, muffler, propeller, spinner, landing gear and wheels.

The C.G. range for the Top Flite Tutor II ranges 2-3/4" [70mm] to 3-3/8" [83mm] from the LE. The recommended starting C.G. is 3" [76mm] back from the LE of the wing at the fuselage. This is the midpoint of the C.G. range specified.

- ❑ 1. If using a Great Planes C.G. Machine to balance the model, set the rulers to 3" [76mm]. If not using a C.G. Machine, use a fine-point felt-tip pen or 1/8" wide tape to accurately mark the recommended C.G. (center of gravity, or “balance point”) on the bottom of the wing 3" [76mm] back from the leading edge on both sides of the fuselage.

- ❑ 2. Place the model on a Great Planes CG Machine, or lift it at the balance point you marked on both sides of the fuselage. Note whether the nose or tail drops. If the tail drops, the model is “tail heavy” and weight must be added to the nose to balance. If, however, the nose drops, then weight must be added to the tail to balance.

- ❑ 3. Add nose or tail weight to balance the model. If nose weight is required it may be added by using a “spinner weight” (GPMQ4645 for the 1 oz. [30g] weight, or GPMQ4646 for the 2 oz. [55g] weight) or Great Planes (GPMQ4485) “stick-on” lead which may be added to the nose. If tail weight is required it may be placed on the right side of the fuselage (opposite the muffler) under the stabilizer.

NOTE: Do not rely upon the adhesive on the back of the lead weight to permanently hold it in place. Over time, fuel and exhaust residue may soften the adhesive and cause the weight to fall off. Use #2 sheet metal screws, RTV silicone or epoxy to permanently hold the weight in place.

IMPORTANT: If you found it necessary to add any weight, recheck the C.G. after the weight has been installed.

Balance the Propeller

Carefully balance your propeller and spare propellers before you fly. An unbalanced prop can be the single most significant cause of vibration that can damage your model. Not only will engine mounting screws and bolts loosen, possibly with disastrous effect, but vibration can also cause your fuel to foam, which will, in turn, cause your engine to run hot or quit.

We use a Top Flite Precision Magnetic Prop Balancer™ (TOPQ5700) in the workshop and keep a Great Planes Fingertip Prop Balancer (GPMQ5000) in our flight box.

Engine Check

If the engine is new, follow the engine manufacturer’s instructions to break-in the engine. After break-in, confirm that the engine runs reliably and smoothly and maintains full power indefinitely. After you run the engine on the model, inspect the model closely to make sure all screws remained tight, the hinges are secure and the prop is secure.

Control Check

With the lines connected to the lead-outs and your assistant holding the model, operate the controls to make sure they move smoothly. If any binding or hesitation is detected, inspect the model and eliminate the problem.

Adjust Leadouts

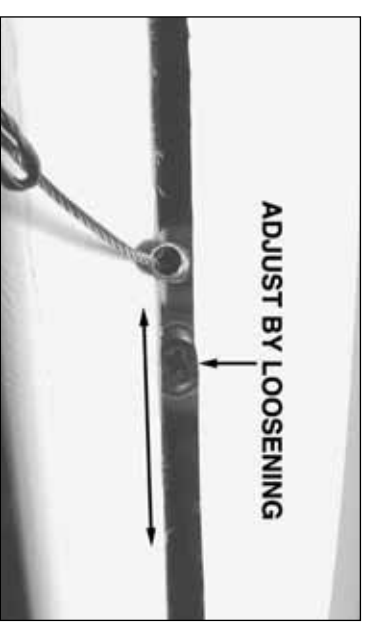

The Top Flite Tutor II ARF is equipped with **adjustable leadouts**. The lines can be adjusted by means of a Phillips head set screw located inside the slot provided for the lead outs. The leadouts can be loosened, then slid fore and aft. When they are in place, tighten the set screw down to prevent the leadouts from moving back and forth in flight. You should also check the leadouts after each flight, making sure each screw is tight.

As a general guideline, positioning the leadouts further aft makes plane pull harder on lines (for windy days), but also makes plane “handle” or react a little slower. This positioning is recommended for less-powerful engines or longer lines and is also a good way to counter the effect of having not enough wing tip weight.

Further forward makes plane pull less hard on lines, thus quickening response. This can be better for calm days, better for faster, more powerful engines or shorter lines. It is also a way to counter the effect of having too much wing tip weight.

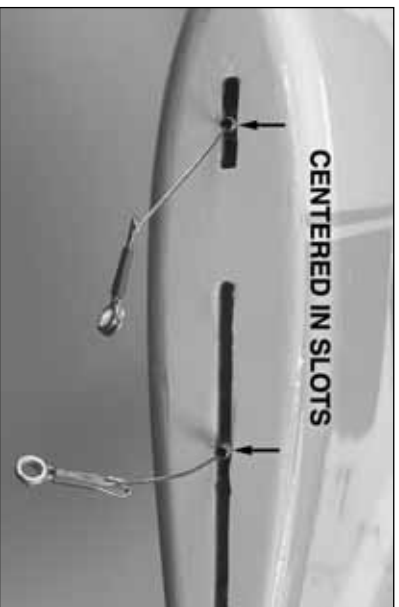

The exact placement of these leadouts will be a matter of experimentation to match your flying style; however, we recommend centering the two leadouts in their slots as a starting point.

ENGINE SAFETY PRECAUTIONS

Keep all engine fuel in a safe place, away from high heat, sparks or flames, as fuel is very flammable. Do not smoke near the engine or fuel; and remember that engine exhaust gives off a great deal of deadly carbon monoxide. Therefore, do not run the engine in a closed room or garage.

Get help from an experienced pilot when learning to operate engines.

Use safety glasses when starting or running engines.

Do not run the engine in an area of loose gravel or sand; the propeller may throw such material in your face or eyes.

Keep your face and body as well as all spectators away from the plane of rotation of the propeller as you start and run the engine.

Keep these items away from the prop: loose clothing, shirt sleeves, ties, scarfs, long hair or loose objects such as pencils or screwdrivers that may fall out of shirt or jacket pockets into the prop.

Use a “chicken stick” or electric starter to start the engine. Do not use your fingers to flip the propeller. Make certain the glow plug clip or connector is secure so that it will not pop off or otherwise get into the running propeller.

Make all engine adjustments from behind the rotating propeller.

The engine gets hot! Do not touch it during or right after operation. Make sure fuel lines are in good condition so fuel will not leak onto a hot engine, causing a fire.

To stop the engine, cut off the fuel supply by closing off the fuel line or following the engine manufacturer's recommendations. Do not use hands, fingers or any other body part to try to stop the engine. Do not throw anything into the propeller of a running engine.

AMA SAFETY CODE (EXCERPTS)

Read and abide by the following Academy of Model Aeronautics Official Safety Code:

General

1. I will not fly my model aircraft in sanctioned events, air shows, or model flying demonstrations until it has been proven to be airworthy by having been previously successfully flight tested.
3. Where established, I will abide by the safety rules for the flying site I use, and I will not willfully and deliberately fly my models in a careless, reckless and/or dangerous manner.
5. I will not fly my model unless it is identified with my name and address or AMA number, on or in the model.
7. I will not operate models with pyrotechnics (any device that explodes, burns, or propels a projectile of any kind).
8. I will not consume alcoholic beverages prior to, nor during, participation in any model operations.
9. Children under 6 years old are only allowed on the flight line as a pilot or while under flight instruction.

Control Line

1. I will subject my complete control system (including safety thong, where applicable) to an inspection and pull test prior to flying. Pull test will be in accordance with the current Competition Regulations for applicable model category. Models not fitting a specific category as detailed shall use those pull test requirements for Control Line Precision Aerobatics.
2. I will assure that my flying area is safely clear of all utility wires or poles.
3. I will assure that my flying area is safely clear of all non-essential participants and spectators before permitting my engine to be started.
4. I will not fly a model closer than 50 feet [15m] to any electrical power line.

CHECKLIST

- 1. Make sure areas exposed to fuel or exhaust residue have been fuel proofed.
- 2. Check the C.G. according to the measurements and procedure provided in the manual.
- 3. Use thread-locking compound on the set screws in the wheel collars that hold on the wheels.
- 4. Add a drop of oil to the axles so the wheels will turn freely.
- 5. Make sure all hinges are securely glued in place.
- 6. Use thin CA to harden all screw holes throughout the airplane.
- 7. Confirm that the flaps and elevators operate freely and smoothly by pulling on the lead-outs.
- 8. Make sure the fuel lines are connected and are not kinked.
- 9. Balance your propeller and spare propellers.
- 10. Tighten the propeller nut and spinner.
- 11. Place your name, address, AMA number and telephone number on your model.
- 12. If you wish to photograph your model, do so before the first flight.

FLYING

Preflight

NOTE: The Top Flite Tutor II ARF is not a beginner's model. It is intended for beginning to advanced stunt pilots who have had some previous control line experience. If you are an inexperienced pilot, seek the assistance of a knowledgeable control line pilot who can help you with your first flights.

Beginning stunt pilots should make their first flights in calm or low wind conditions. Stronger winds may blow the model inward which will decrease line tension resulting in loss of control. If the lines ever do go slack, quickly step back to tighten the lines and regain control. Of course, this is most likely to happen, and should be expected, as the model approaches the upwind half of the circle.

Place the model and starting equipment where the wind will be behind the model when it is released for takeoff.

For the first half-circle (during the brief period when the pilot has the least control before the model is "up to speed") the wind will push the model outward to maintain line tension.

Mark the center of the flying circle with paint, chalk or a suitable object (such as a shop towel) so you won't wander. This is especially important if the flying area is limited.

With your assistant holding the model, walk from the model toward the handle in the center of the circle while using your fingers to keep the lines separated. This will ensure that the lines are not twisted and are free to operate the controls.

While the pilot is holding the lines, the assistant should walk the model once around the circle to be certain the flight path is clear and to double-check that there are no obstructions that could snag the lines.

The pilot should double-check the operation of the controls by pulling and pushing on the handle and having the assistant signal what the controls are doing ("up" and "down").

Takeoff

When both the pilot and assistant are ready, the model may be fueled and started. Once the engine is running and the model is ready to be released, the assistant should point the nose of the model slightly away from the inside of the circle. This will help keep the lines taut for the first few feet until the model gets going.

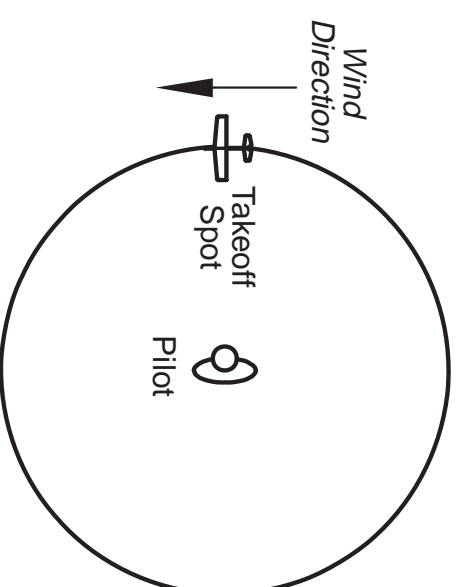

Upon the pilot's signal, the assistant may release the model—never push the model forward as doing so may result in a crash.

The pilot should be ready—especially during takeoff—to briefly step back to maintain line tension until the model has gained enough air speed to achieve line tension on its own. Allow the model to roll out and gain enough speed to become airborne. When enough speed has been gained, the pilot may raise his arm slightly, giving "up" elevator command, thus allowing the model to leave the ground.

Once the model has lifted, maintain a slow and steady climb until a comfortable altitude has been reached (usually between "eye-level" and approximately ten feet in the air). The lines must remain taut throughout the entire flight. If the lines ever do go slack, the pilot will not have control of the model. During most situations the model's factory built-in features will allow it to maintain good line tension, but on occasions when the wind blows the model inward or the model becomes too slow the modeler must anticipate or notice a decrease in "pull" and quickly step backward to tighten the lines and regain control.

To climb, the pilot will slowly raise his arm. To descend, the pilot will slowly lower his arm. To maintain level flight the pilot will hold his arm horizontally. Beginning

pilots should control the model by keeping their arms straight and bending at the elbow with little or no wrist movement. Later, when they become more experienced, wrist movement may be increased to increase control response. All control inputs should be smooth. Continue flying the model in a level attitude, getting used to how the controls react and how the model “feels.” Do this until the engine runs out of fuel. Actual flight time depends on several factors, such as the engine size and brand, needle valve setting, propeller size, fuel, atmospheric conditions, etc., but you can expect flight times around 7-8 minutes.

Landing

When the engine starts to sputter and/or speed up, this is an indication that the tank is nearly empty. Continue to fly the model in a level attitude until the engine finally quits. The same as any time the model slows, the pilot should step back to keep the lines taut and maintain control. Allow the model to descend until it is about two feet off the ground. When the model has lost nearly all flying speed and is a foot or two from the ground, the pilot should raise his arm to keep the lines taut and apply full up elevator, allowing the model to gently touch down.

After the model has come to a stop the assistant may retrieve the model and return it to the starting area. In doing so the lines should be kept taut so they do not become twisted or entangled.

Clean the model using paper towels and household cleaner to wipe off exhaust residue. Inspect the model thoroughly, looking for loose fasteners and signs of damage or fatigue. Also make sure the prop has not been damaged. Perform any maintenance necessary to prepare the model for the next flight.

At the end of the flying session any unspent fuel should be drained from the tank.

After you have become familiar with the way your Tutor II ARF flies and you are ready to begin performing stunts, seek the assistance of an experienced stunt pilot before attempting to learn new maneuvers on your own. Almost any control line stunt maneuvers are started with the model downwind from the pilot, i.e. wind on the pilot's back. Consult the AMA Control Line section for stunt maneuvers.

One final note about flying your model: Have a goal or flight plan in mind for every flight. This can be learning a new maneuver(s), improving a maneuver(s) you already know, or learning how the model behaves in certain conditions (such as when testing different propellers or fuel). This is not necessarily to improve your skills (though it is never a bad ideal), but more importantly so you do not surprise yourself by impulsively attempting a maneuver and suddenly finding that you've run out of time, altitude or airspeed. Every maneuver should be deliberate, not impulsive. For example, if you're going to do a loop, check your altitude and mind the wind direction. A flight plan greatly reduces the chances of crashing your model just because of poor planning and impulsive moves. Remember to think!

Have a ball, keep the lines taut and always fly in a safe manner.

GOOD LUCK, GREAT FLYING, AND HAVE FUN!

This model belongs to:	
_____	Name
_____	Address
_____	City, State, Zip
_____	Phone number
_____	AMA number

- O.S. Engines®**
- .40 LA-S Control Line Engine with Muffler (OSMG1440)**
- .46 LA-S Control Line Engine with Muffler (OSMG1446)**



The O.S. .40 and .46 LA-S offer the proven power of LA Series R/C sport engines – but are engineered for the special requirements of control line flying, replacing the carburetor with a venturi that keeps the engine running at a constant speed. A remotely mounted needle valve keeps your hands safely distanced from the spinning prop during adjustments. An O-ring helps seal the needle against fuel and air leaks, while heavy-duty webbing reinforces the blue-finish, one-piece crankcase in high-stress areas. Includes E-3030 muffler, muffler mounting screws, #A3 glow plug, and 2-year warranty. Fuel with 10-20% nitro and 18% oil content recommended.

AMA STUNT MANEUVERS

Here are some of the AMA Stunt Maneuvers. Refer to the AMA Rule Book for full descriptions.

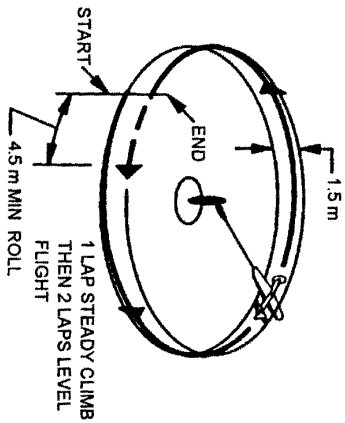

Takeoff

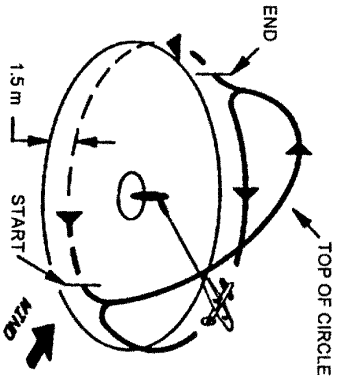

Reverse Wingovers

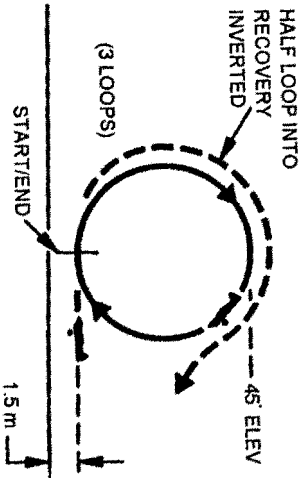

Consecutive Inside Loops

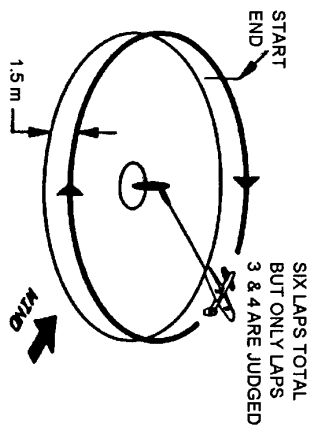

Inverted Flight

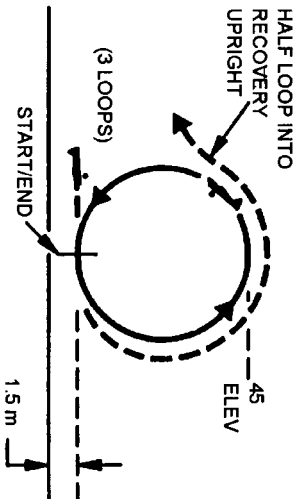

Consecutive Outside Loops

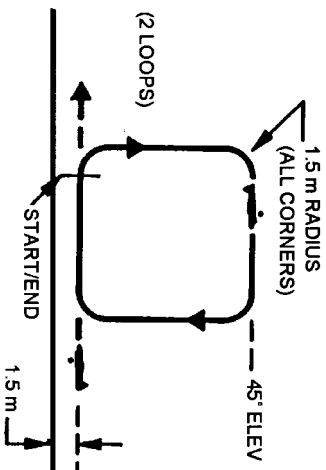

Consecutive Inside Square Loops

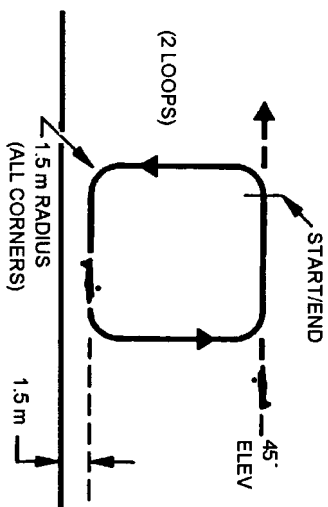

Consecutive Outside Square Loops

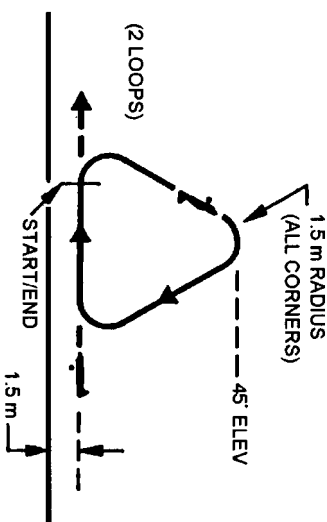

Consecutive Inside Triangular Loops

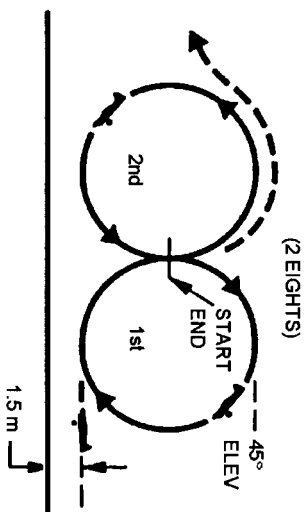

Horizontal Eights

FLIGHT LOG

DATE

COMMENTS

Started Assembly

Finished Assembly

First Flight

First Loop

First Inverted Flight

First Wingover

DATE	COMMENTS
	Started Assembly
	Finished Assembly
	First Flight
	First Loop
	First Inverted Flight
	First Wingover