

**PLEASE NOTE THE FOLLOWING CHANGES:**

- The die-cut patterns on page 6 indicate that two CRSGF07's are included in the kit. This is incorrect. Only one is included. However, a separate CRSGF07A is provided to supply the additional F-1 required to build the fuselage.
- On page 12, after test fitting the hinges in the elevators and stab, mark "bevel to" lines on the top and bottom of the elevators' LE. Shape the LE to a "V".
- On page 18, step 7, position the 7/8" x 1-1/4" x 9-1/2" balsa dihedral jig block so that the wing center section is raised 7/8" from the building table.
- In certain kits, the two parts ULGD and URGD on die-cut sheet CRSGF14 are mislabeled. Refer to the photo on page 24, step 16 for the correct labeling. The photo is correct.
- On page 25, after completing step 21, skip forward and perform steps 27 through 30. After completing step 30, return to step 22 and use epoxy to glue the 1/4" x 1" x 1" plywood stab retainer block to the stab base before gluing the plywood stab base and stab base supports to the aft fuse plate. See figure 1.

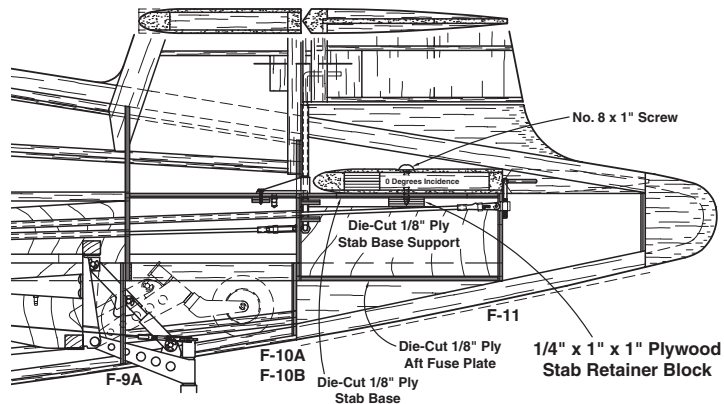

figure 1