

# P-47D THUNDERBOLT



## WARRANTY.....

Top Flite Models guarantees this kit to be free of defects in both materials and workmanship at the date of purchase. This warranty does not cover any component parts damaged by use or modification. In no case shall Top Flite's liability exceed the original cost of the purchased kit. Further, Top Flite reserves the right to change or modify this warranty without notice.

In that Top Flite has no control over the final assembly or material used for final assembly, no liability shall be assumed nor accepted for any damage resulting from the use by the user of the final user-assembled product. By the act of using the user-assembled product the user accepts all resulting liability.

If the buyer is not prepared to accept the liability associated with the use of this product, the buyer is advised to immediately return this kit in new and unused condition to the place of purchase.



**Top Flite Models**  
**P.O. Box 788**  
**Urbana, IL 61801**  
**Technical Assistance - Call (217) 398-8970**

READ THROUGH THIS INSTRUCTION BOOK FIRST. IT CONTAINS IMPORTANT INSTRUCTIONS AND WARNINGS CONCERNING THE ASSEMBLY AND USE OF THIS MODEL.

# TABLE OF CONTENTS

- Introduction** .....3
- About the airfoils**.....3
- Precautions**.....3
- Decisions you must make early in the building process** .....4
  - Engine selection .....4
  - Razorback or Bubble canopy .....4
  - Retracts or fixed gear .....4
  - Wheel selection .....4
  - Flaps.....4
- Top Flite Scale Accessories**.....5
  - Scale Cockpit Interior .....5
  - Replica Radial Engine .....5
  - Static Display Prop .....5
  - Drop Tanks .....5
- Notes for the competition Minded modelers and deviations from scale**.....5
- Documentation** .....5
- Other Items required**.....5
  - Optional .....5
  - Suggested Supplies and Tools .....6
  - Die-Cut Patterns Page .....7-8
  - Common Abbreviations Used in the Book and on the plans.....9
  - Metric Conversion Chart.....9
  - Types Of Wood.....9
  - Get Ready to build.....9
- Build the Tail Surfaces** .....9
  - Build the stabilizer and elevators.....9
  - Build the fin and rudder .....13
- Build the Fuselage** .....15
  - Top Frame Assembly .....15

- Razorback .....16
- Bubble Canopy .....17
- Glue the stabilizer and fin to the fuselage ... 18
- Complete The Fuse Top Razorback .....19
- Complete The Fuse Top Bubble Canopy .....20
- Final fit the canopy Razorback.....20
- Final fit the canopy Bubble Canopy .....20
- Final steps before framing the lower fuse.....21
- Frame the fuse bottom .....21
  - Tail Gear Installation .....22
  - Fit the intercooler air exits .....24
  - Sheet the fuse bottom .....25
- Install the engine .....26
- Install servo tray .....27
- Build the wing**.....28
  - Preparation .....28
  - Retract modification for Century Jet Retracts..28
  - Build the wing panels.....29
  - Join the wing panels.....33
  - Preparations before adding bottom wing sheeting.....34
  - Sheet the bottom of the wing.....34
  - Prepare the wing for the top sheeting.....35
  - Sheet the top of the wing.....37
  - Build the flaps .....38
  - Fit the flaps .....39
  - Build the ailerons .....40
- Mount the wing to the fuse**.....41
  - Build the wing fillet.....42
  - Build the wing belly pan.....43
  - Sheet the belly pan.....44
- Build and fit the cowl** .....45
- Finish preparation**.....46
  - Final sanding .....46
  - Fuelproofing.....46

- Balance the airplane Laterally .....46
- Finishing** .....46
  - Covering .....46
  - Recommended Covering Sequence.....47
  - Apply the decals .....47
  - Apply panel lines to the model.....48
  - Painting.....48
  - Hinging .....48
- Final Assembly**.....49
  - Retracts .....49
  - Cockpit finishing .....50
  - Optional cockpit interior .....50
  - Add the molded scale details.....50
  - Install receiver, switch and battery .....51
  - Final hookups and checks .....51
  - Control surface throws.....51
  - Balance your model.....52
- Preflight**.....52
  - Charge batteries .....52
  - Find a safe place to fly.....52
  - Ground check the model .....52
  - Range check your radio.....52
  - Engine safety precautions .....52
- AMA Safety code**.....53
- Flying**.....53
  - Takeoff.....53
  - Flying .....54
  - Landing.....54
- Three-view drawing – Back cover**

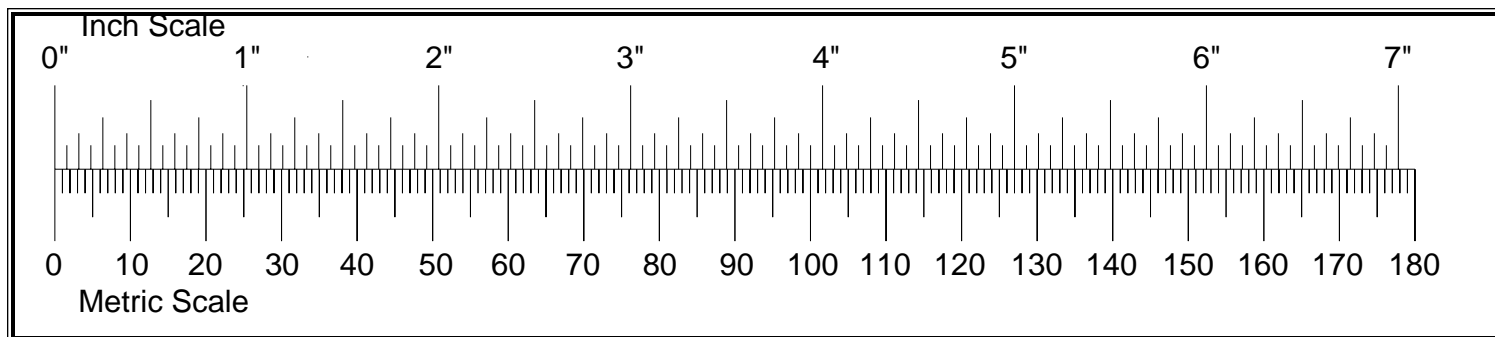

## PROTECT YOUR MODEL, YOURSELF & OTHERS – FOLLOW THIS IMPORTANT SAFETY PRECAUTION

Your P-47 Thunderbolt is not a toy, but rather a sophisticated, working model that functions very much like an actual airplane.

Because of its performance, the Thunderbolt, if not assembled and operated correctly, could possibly cause injury to yourself or spectators and damage property.

**To make your R/C modeling experience totally enjoyable, we recommend that you get experienced, knowledgeable help with assembly and during your first flights.** You'll learn faster and avoid risking your model before you're truly ready to solo. Your local hobby shop has information about flying clubs in your area whose membership includes qualified instructors.

You can also contact the national Academy of Model Aeronautics (AMA), which has more than 2,300 chartered clubs across the country. Through any one of them, instructor training programs and insured newcomer training are available.

Contact the AMA at the address or toll-free phone number below:



**Academy of Model Aeronautics**  
5151 East Memorial Drive  
Muncie, IN 47302-9252  
Telephone: (800) 435-9262  
Fax: (317) 741-0057

## INTRODUCTION

Thank you for purchasing the **Top Flite GOLD EDITION P-47 Thunderbolt**.

The P-47 has long been recognized as an excellent modeling subject. The wing plan form, long tail moment and generous tail areas give the P-47 modeler an excellent starting point. Top Flite builds on these features with custom airfoils, 2-1/2 degrees of washout in the wing and 2-1/2 degrees of right thrust. Top Flite's advanced 3-D computer engineering and interlocking construction techniques combined with additional wing sheeting jigs help you build a straight, lightweight model. The result is a model warbird with exceptional flight characteristics. The Top Flite P-47D is smooth and forgiving both around the runway and in high speed, high "G" flight.

Although this is a scale warbird with plenty of detail, the builder can expect surprising results because both the wing and fuse structure frame up so fast. There is lots of sheeting to do over the quickly framed structure but patterns are provided with hints on how to prepare the sheets. When you show up at the flying field with the Top Flite Gold Edition P-47 your friends will see an "all out," scale warbird but you'll recall a straightforward building project with no complications (but you can keep that a secret). Top Flite's CAD designed structure with interlocking parts and traditional wood construction make this possible.

## ABOUT THE AIRFOILS

Top Flite Design Engineer, David J. Ribbe, and Low Speed Airfoil Expert, Dr. Michael Selig, sat down over pizza to discuss what areas of the model aircraft market could benefit from better airfoils. One area that was identified was model warbirds as they tend to have more wing taper and higher wing loading than most sport/aerobatic models. A warbird would benefit from a set of airfoils that had better lift for a slower stall speed and smooth, gentle stall characteristics.

Dave set out to develop a list of parameters; things such as... stall speed, root chord, tip chord and thickness, while making sure there would be adequate room for retracts, compatibility with flaps, spars, etc. These restraints were sent to Mike, so he could design an airfoil around them. Mike used a computer, with the latest low speed airfoil design code to fine tune each airfoil's shape.

The result is a root (S8036) and tip (S8037) airfoil specifically designed for the needs of a warbird like the P-47. We couldn't be happier with the results.

**Please inspect all parts carefully before starting to build! If any parts are missing, broken or defective, or if you have any questions about building or flying this model, please call us at (217) 398-8970 and we'll be glad to help. If you are calling for replacement parts, please look up the part numbers and the kit identification number (stamped on the end of the carton) and have them ready when calling.**

## PRECAUTIONS

1. You must build the plane **according to the plans and instructions**. Do not alter or modify the model, as doing so may result in an unsafe or unflyable model. **In a few cases the plans and instructions may differ slightly from the photos. In those instances you should assume the plans and written instructions are correct.**
2. You must take time to **build straight, true and strong**.
3. You must use a proper R/C **radio** that is in first-class condition, the correct-sized **engine** and correct **components** (fuel tank, wheels, etc.) throughout your building process.
4. You must properly **install** all R/C and other components so that the model operates properly on the ground and in the air.

5. You must **test** the operation of the model before the first and each successive flight to insure that all equipment is operating and you must make certain that the model has remained structurally sound. Be sure to check external nylon clevises often and replace them if they show signs of wear.

6. You must **fly** the model **only with the competent help** of a well-experienced R/C pilot if you are not already an experienced R/C pilot at this time.

**Remember: Take your time, follow directions to end up with a well-built model that is straight and true.**

**NOTE:** We, as the kit manufacturer, can provide you with a top quality kit and great instructions, but ultimately the quality and performance of your finished model depends on how **you** build it. Therefore, we cannot in any way guarantee the performance of your completed model, and no representations are expressed or implied as to the performance or safety of your completed model aircraft.

## DECISIONS YOU MUST MAKE EARLY IN THE BUILDING PROCESS

### ENGINE SELECTION

The recommended engine range is as follows:

.61 to .90 cu. in. **2-stroke**  
.91 to .120 cu. in. **4-stroke**

The P-47 Thunderbolt will fly well with any of the recommended engines. The 4-stroke engines and most .90 2-stroke engines will turn a larger prop at lower rpm's. This is often desirable for scale realism. If you use a .61 2-stroke, a Schnuerle-ported engine is preferred. The prototype P-47, weighing 10 pounds with all of the options including flaps, retractable landing gear and a releasable 108 gallon (scale of course) drop tank, was first flown with the Super Tigre S-75K. This proved to be the **ideal size** for a two-stroke power plant – large enough to provide plenty of reserve power for aerobatics and sport flying, yet small enough to represent scale speeds when throttled back a little.

A .61-size Schnurle-ported engine will also provide plenty of power for your P-47 – especially if mostly scale flying is in your repertoire. 1.20 4-stroke engines should be reserved for proficient flyers who can handle a model with a higher wing loading and are used to the high torque tendencies of such engines (lots of right rudder on takeoff).

The included adjustable engine mount will hold a range of engines from a .61 2-stroke through 1.20 4-stroke.

A special Top Flite header and muffler is available that will fit inside your cowling. They are designed for 2-stroke engines as used on our prototype:

Header for O.S .61SF (TOPQ7920)  
Header for Super Tigre S61K-S75K (TOPQ7925)  
Header for Super Tigre G75 (TOPQ7926)  
Muffler for above (TOPQ7915)

### RAZORBACK OR BUBBLE CANOPY VERSION

Your Top Flite Gold Edition P-47D Thunderbolt kit includes the parts and instructions to build either the P-47D-23 known as the "Razorback," or the P-47D-25 "Bubble Canopy" version. However, only the Razorback canopy is included in the kit so if you decide to build the Bubble Canopy version, all you need to do is purchase the canopy set, which is offered separately (TOPA1616). You do not need to make this decision until about halfway through fuselage construction.

### RETRACTS OR FIXED GEAR

The choice of retractable or fixed landing gear is yours. Retracts, once again, add to the "presence" of your model in the air and really get the attention of fellow modelers (and spectators). Instructions are included for either option and are quite detailed for retract installation so no difficulty should be expected. Should you decide

to install retracts, there are the two types – wire-and-coil or rigid struts with an oleo. Standard wire struts absorb more shock on rough landings and are less stressful to the airframe while the oleo struts offer greater scale appearance. The standard setup uses the Robart 606 HD pneumatic system with 3/16" wire. Robart 650 oleo struts may be used and can be purchased separately. Century Jet Models also offers the TF P-47 pneumatic retract package with oleo struts. See the "Other Items Required" section and the "Retract Installation" section of the manual for more information.

### WHEEL SELECTION

Scale tire size for the P-47 is over 4" but we recommend 3-1/2" wheels. 3-3/4" wheels will retract into the wing **if extra care is taken during construction.**

### FLAPS

This model is designed to incorporate scale flaps; however, be assured that flaps are **optional and not necessary** for an excellent flying experience. The only difference is, without flaps, the takeoff roll is a little longer and the landing speed is slightly faster.

The flaps are not difficult to assemble, but they do require good craftsmanship if they are to fit well. They add nicely to the model's flight characteristics and scale appearance. Only slight trim correction is needed when flaps are deployed with the recommended throws. Flaps add **drag and lift** to the model on landing approaches, which gives the plane a very steady, locked-in feel. The flaps require one extra channel, a Y-harness and two standard servos. They are a highly recommended *fun* option for those who wish to install them. More information on the use of the flaps may be found in the "Flying" section.

## TOP FLITE SCALE ACCESSORIES

**SCALE COCKPIT INTERIOR:** Another exciting option made specifically for your Top Flite Gold Edition P-47 is the Scale Cockpit Interior. It goes without saying (we'll say it anyway) that a full cockpit interior really adds to the realism and overall appearance of your model. Since it is made for the P-47, installation is easy. This can be done about 3/4 of the way through fuselage construction or it may be saved until after covering is finished. We urge you to take advantage of this option as rarely do you find such details offered by the manufacturer specifically for their own model. Instructions for painting and finishing are included with the cockpit kit (TOPQ8405).

**REPLICA RADIAL ENGINE:** A final touch of scale realism is possible by installing the specially designed 9-cylinder replica radial engine inside the cowl. The replica radial adds significantly to the look of the model and, when backed up by 1/8" lite-ply, doubles as a cooling baffle for the real engine. Made from vacuum-formed ABS, the replica radial is easy to assemble and can be modified to suit any engine installation (TOPQ7902).

**DROP TANKS:** To increase its range, the P-47 used one or more drop tanks. With the 108 gallon "Paper" Tank (TOPQ7899) and/or the 75 gallon Tank (TOPQ7900) you can give the P-47 that business-like "loaded down" look and add even further to the scale realism. The release mechanism is included with the tanks so they can be made releasable in flight or may be manually disconnected. Scale pylons are included for the outboard Wing Tanks.

## NOTES FOR THE COMPETITION-MINDED MODELERS AND DEVIATIONS FROM SCALE

The P-47D-23 Razorback was instrumental in turning the tide of WWII. It was escorting bombers to targets before the longer ranged Mustangs appeared in significant numbers. The "Bonnie" trim scheme shown on the box was done with MonoKote film and the decals supplied in the kit.

The main landing gear is simplified. They pivot at the scale location, but the wells are moved forward, slightly ahead of the main spar. The model's tires (3-1/2" to 3-3/4") are smaller than scale in order to fit into the space provided, but the stance on the ground is scale.

The elevator and rudder hinge lines have been modified in order to simplify assembly and use standard model hinging techniques.

The true scale factor of the Top Flite P-47 is 1:7.77, or approximately 1/8.

## DOCUMENTATION

Following are some of the books that are available showing various details of the P-47:

**Thunderbolt – A Documentary History of the Republic P-47**, Roger A. Freeman.

Contains the excellent 5-view drawings that the Top Flite P-47 was designed around. It also contains many photos and historical information.

**P-47 Thunderbolt – In Action**, Squadron/Signal  
Features "Bonnie" on the cover and includes 3-views and many photos and illustrations.

## OTHER ITEMS REQUIRED

Item numbers (GPMQ4130) are suggested part numbers recognized by distributors and hobby shops and are listed for your ordering convenience. **TOP** is the Top Flite brand, **GPM** is the Great Planes brand and **HCA** is the prefix for the Hobbico brand.

- 4 to 7 channel radio with 5 to 8 servos.
  - 6" Aileron servo extension cords – Futaba J HCAM2000
  - Engine (see page 4)
  - Propellers (see engine instruction manual for proper propeller sizes)
  - 14 oz. Fuel Tank – GPMQ4106
  - 3-1/2" Main Wheels – Robart ROBQ1535
  - 1-1/4" tailwheel – GPMQ4242
  - 3/16" Wheel Collars – GPMQ4308, pkg. of 4
  - 3/32" Wheel Collars – GPMQ4302, pkg. of 4
  - Top Flite MonoKote covering, 3 rolls (see *Finishing* section)
  - Paint (see *Finishing* section)
  - Medium Silicone Fuel Tubing – GPMQ4131
  - 1/2" Latex Foam Rubber Padding – HCAQ1050
  - Flexible cable throttle pushrod – GPMQ3700
- or-
- 1/16" x 12" threaded-end pushrod

## OPTIONAL

### For Flaps:

- Hobbico "Y" Harness (Fut J) – HCAM2500
- or-
- Futaba Dual Servo Extension – FUTM4130
  - 6 Pcs. Robart #309 Super Hinge Points large – ROBQ2509, pkg. of 6

### For Retractable Landing Gear:

- Robart #606 85° HD Pneumatic Retracts – ROBQ0006
- Robart #188 Air Control Kit – ROBQ2388
- Robart #164G Hand Pump – ROBQ2363
- 3 Pcs. Robart #190 Quick Connectors – ROBQ2395 pkg. of 2

- Robart #650 Straight Robostruts – ROBQ1700 (optional)
- Robart #189 Air Restrictor Set – ROBQ2389 (optional)

-or-

- Century Jet Models Retracts
- Top Flite Header & In Cowl Muffler (See page 4 for description)
- Scale Pilot figure (1/6 Scale Williams Brothers WBRQ2472 Military or WBRQ2476 Standard)
- Fuel Filler Valve – GPMQ4160
- Fuel Filter – GPMQ4250
- Top Flite 75 Gal. Drop Tank(s) – TOPQ7900
- Top Flite 108 Gal. Drop Tank – TOPQ7899
- Sullivan #507 Gold-N-Rod for releasable drop tanks – SULQ3007
- Screw-Lock Pushrod Connectors – GPMQ3870 (optional)
- Switch & Charge Jack Mount – GPMM1000
- Top Flite Cockpit Interior Kit – TOPQ8405
- Top Flite 1/8th Scale Replica Radial Engine – TOPQ7902
- #4x1/2 Button head screw – GPMQ3124

### **SUGGESTED SUPPLIES AND TOOLS**

*We recommend Top Flite Supreme™ CA and Epoxy*

- 2 oz. CA (Thin) – TOPR1003
- 2 oz. CA+ (Medium) – TOPR1008
- 1 oz. CA- (Thick) – TOPR1011
- CA Applicator Tips – HCAR3780
- CA Accelerator – TOPR1025
- 6-Minute Epoxy – TOPR1040
- 30-Minute Epoxy – TOPR1043
- Wood Glue – GPMR6160 (optional)
- Pacer Z-560 Canopy Glue – PAAR3300 (optional)
- Hand or Electric Drill
- Silver Solder w/flux – GPMR8070
- Sealing Iron – TOPR2100
- Heat Gun – TOPR2000 (optional)
- Hot Sock – TOPR2175 (optional)
- Trim Seal Tool™ – TOPR2200 (optional)
- #1 Knife handle – XACR4305
- #11 Blades (100 qty.) – HCAR0311

- Single Edge Razor Blades – HCAR0312
- Razor Saw
- Common pliers
- Screwdrivers (Phillips and flat head)
- Robart Super Stand – ROBQ1401
- T-Pins – HCAR5100 small, HCAR5150 medium, HCAR5200 large
- Straightedge–Fourmost Non-Slip – FORR2149
- 3/4 oz. Fiberglass Cloth – HCAR5000 (Optional)
- Masking Tape
- Sandpaper (see Hot Tip on this page)
- Easy-Touch™ Bar Sanders – GPMR1670
- Waxed Paper
- HobbyLite™ Balsa Filler – HCAR3401
- 1/8", 3/16", 1/4", 7/32" brass tube (optional)
- Tap wrench
- 1/4-20 Tap w/drill bit – GPMR8105
- 8-32 Tap w/drill bit – GPMR8103
- Denatured or Isopropyl Alcohol
- Dremel® Moto-Tool™ or similar w/sanding drum, cutting burr, cut off wrench (optional)
- 9/64" ball end hex wrench – GPMR8004
- Kyosho® Curved Scissors – KYOR1010
- Razor Plane – MASR1510
- String
- Auto body filler (Bondo® or similar)
- 3M #75 Repositionable Spray Adhesive

- Drill Bits:
- 1/16"     3/16"
  - 5/64"     7/32"
  - 1/8"     15/64"
  - 9/64"     1/4"
  - 17/64"



On our workbench, we have four 11" **Great Planes® Easy-Touch™ Bar Sanders**, equipped with #50, #80, #150 and #220-grit sandpaper. This setup is all that is required for almost any sanding task. Custom sanding blocks can be made from balsa for sanding hard to reach spots. We also keep some #320-grit wet-or-dry sandpaper handy for finish sanding before covering.



Great Planes **Easy-Touch Bar Sanders** are made from lightweight extruded aluminum and can be found at most hobby shops. They are available in two sizes – 11" (GPMR6170) for most general purpose sanding and 22" (GPMR6172) for long surfaces such as wing leading edges. We recommend using the 2" wide self adhesive sandpaper sold in 12' rolls by Great Planes. Standard sandpaper can be attached by gluing it to the sander with brush-on rubber cement. Apply the rubber cement to both the bottom of the sander and the back of the sandpaper. When both surfaces are dry to the touch, press the sandpaper firmly onto the sander. Spray adhesive can be used for this purpose but it's much harder to remove the sandpaper when you need to replace it. Use a knife blade for cutting sandpaper, not your good scissors!

# DIE-CUT PATTERNS

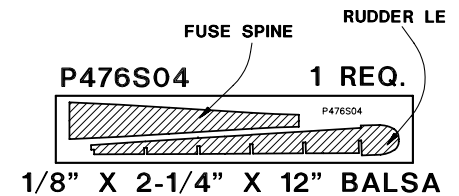
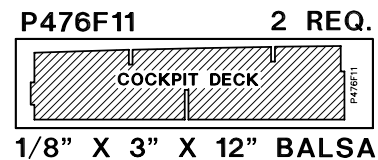
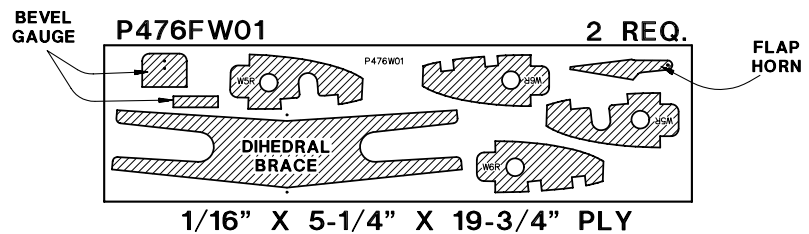
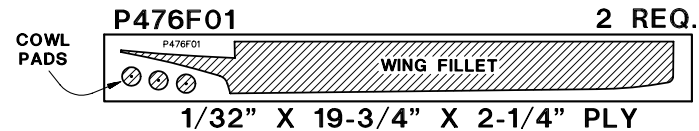
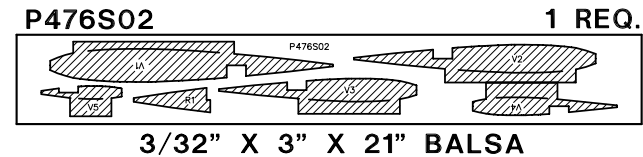
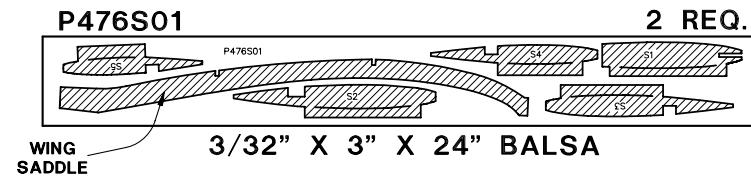
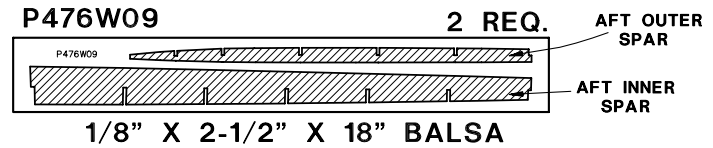
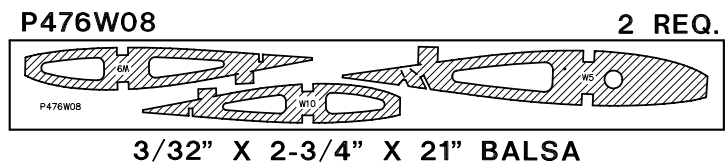
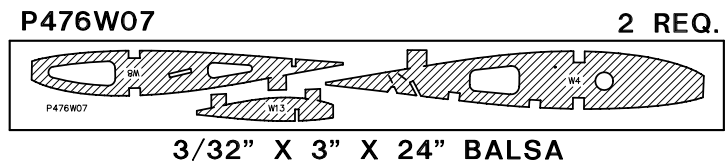
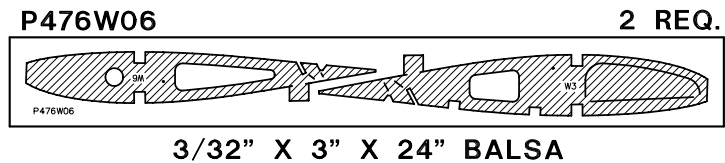
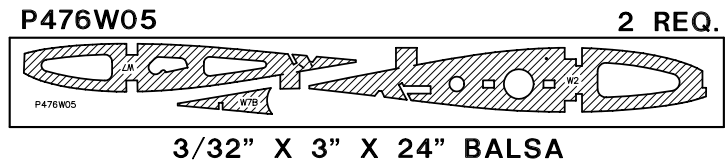
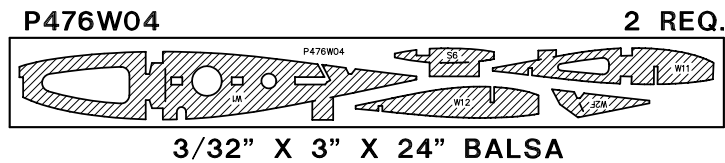
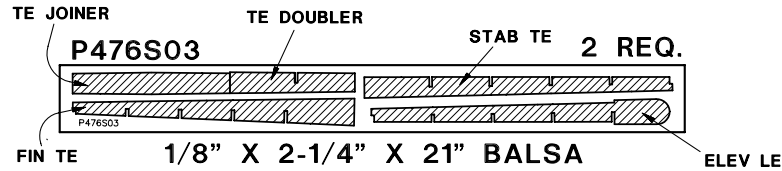

# DIE-CUT PATTERNS

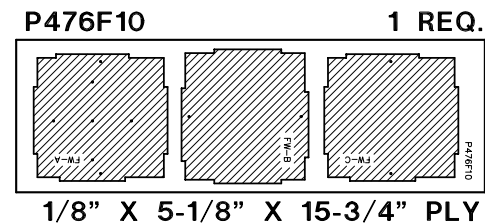
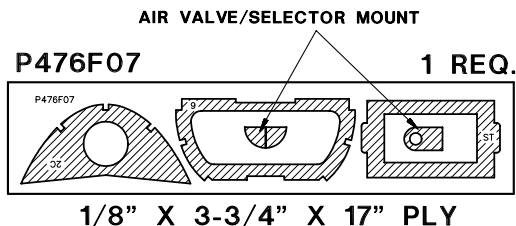
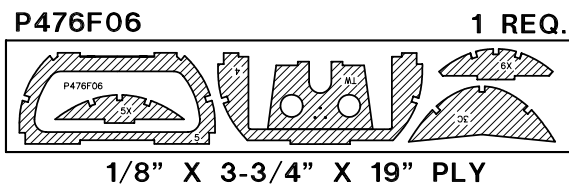
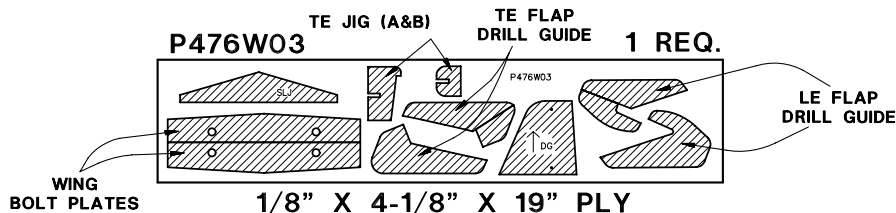
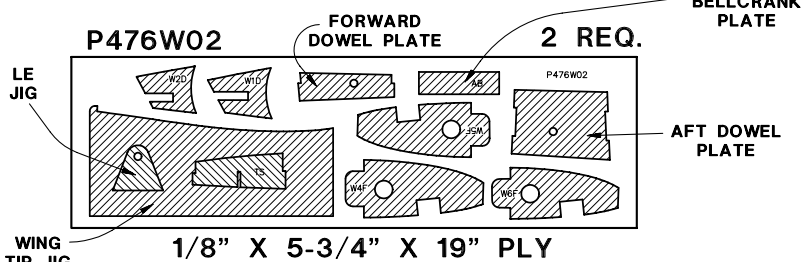
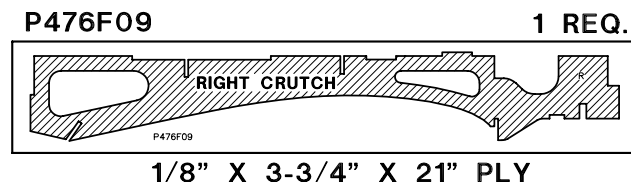
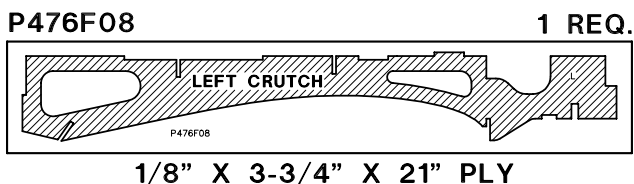
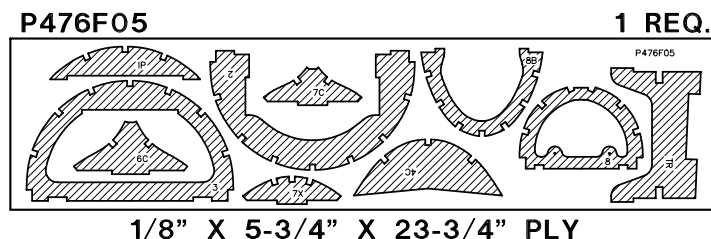
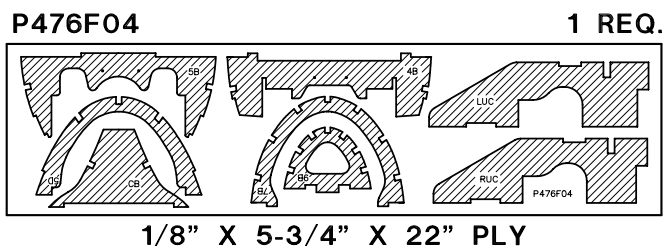
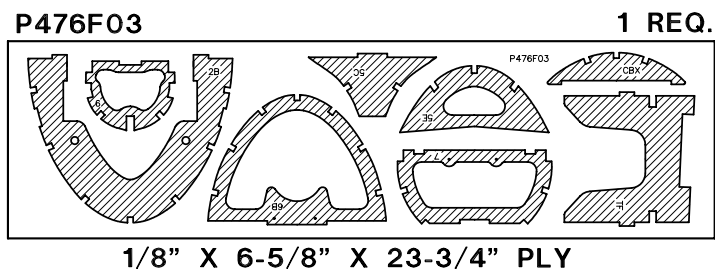
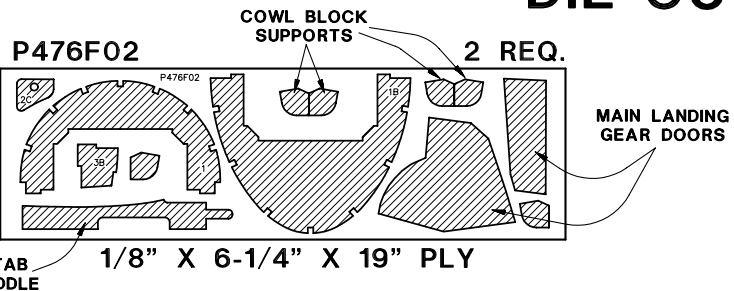

## COMMON ABBREVIATIONS USED IN THIS BOOK AND ON THE PLANS:

Deg = Degrees  
Fuse = Fuselage  
LE = Leading Edge (front)  
LG = Landing Gear  
Lt = Left  
Ply = Plywood  
Rt = Right  
Stab = Stabilizer  
TE = Trailing Edge (rear)  
" = Inches  
Elev = Elevator

## METRIC CONVERSION CHART: INCHES X 25.4 = MM (CONVERSION FACTOR)

1/64" = .4 mm  
1/32" = .8 mm  
1/16" = 1.6 mm  
3/32" = 2.4 mm  
1/8" = 3.2 mm  
5/32" = 4.0 mm  
3/16" = 4.8 mm  
1/4" = 6.4 mm  
3/8" = 9.5 mm  
1/2" = 12.7 mm  
5/8" = 15.9 mm  
3/4" = 19.0 mm  
1" = 25.4 mm  
2" = 50.8 mm  
3" = 76.2 mm  
6" = 152.4 mm  
12" = 304.8 mm  
18" = 457.2 mm  
21" = 533.4 mm  
24" = 609.6 mm  
30" = 762.0 mm  
36" = 914.4 mm

## TYPES OF WOOD:

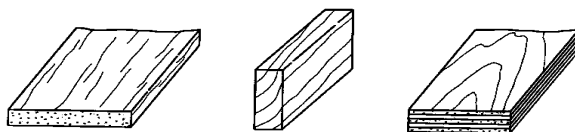

Balsa

Basswood

Ply

## GET READY TO BUILD

1. Unroll the plan sheets. Reroll the plan inside-out to make it lie flat.
2. Remove all parts from the box. As you do, determine the name of each part by comparing it with the plan and the parts list included with this kit. Using a felt-tip or ball-point pen, lightly write the part **name** or **size** on each piece to avoid confusion later. Use the die-cut patterns shown on pages 7 and 8 to identify the die-cut parts and mark them **before** removing them from the sheet. Stock up on scrap balsa by saving the large parts of the remainder of the die-cut sheets after the parts have been removed.

If any of the die-cut parts are difficult to remove, do not try to force them! Instead, cut around the parts with a hobby knife. After removing the die-cut parts, use your Easy-Touch or sanding block to **lightly** sand the edges to remove any die-cutting irregularities.

3. As you identify and mark the parts, separate them into groups, such as **fuse** (fuselage), **wing**, **fin**, **stab** (stabilizer) and **hardware**.



Zipper-top food storage bags are handy to store your small parts as you sort, identify and separate them into sub-assemblies.

## BUILD THE TAIL SURFACES

### BUILD THE STABILIZER AND ELEVATORS

1. Always build on a flat surface. Refer to the plans to identify the parts and their locations. *The plans may be cut apart if space is a problem.* Tape them to your building board and cover them with waxed paper.
2. Remove both sets of the die-cut 3/32" balsa stab **Ribs S-1** through **S-6** and the die-cut 1/8" balsa stab **Trailing Edges (TE's)** and **TE Doublers**. There is a **Jig Tab** on the bottom edge of each of the ribs. If any of these break off, carefully glue them back on with thin CA. Lightly sand any imperfections. Use a pen to mark the extensions of the bottom edge of the ribs across the fore and aft ends of the jig tabs. These marks will help when you trim off the jig tabs later.
3. Cut the **Stab Leading Edges (LE's)** 1/4" longer than shown on the plans from two pieces of 1/4" x 11-7/8" tapered balsa stock.

**HINT:** Bevel the front edge of the ribs to match the **sweep** angle of the LE. This will give you a better fit and a stronger glue joint.

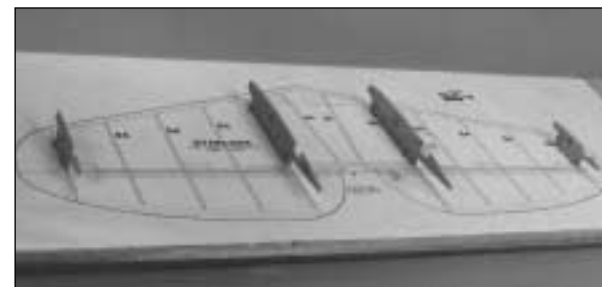

4. Pin only the **S-2** ribs and the **S-6** ribs to the building board over their locations on the plan.

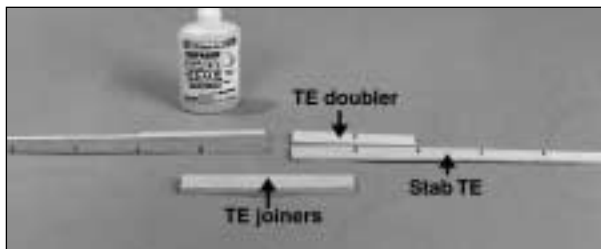

□ 5. With the notch in one of the stab TE's aligned with the notch in a stab TE doubler, glue the pieces together. Do the same with the other stab TE and doubler. **Make a right and a left half.** Glue the die-cut 1/8" balsa stab **TE Joiners** together.

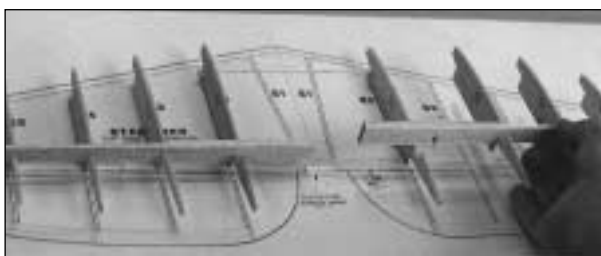

□ 6. **Without using any glue**, install ribs S3, S4 and S5 in the notches in the TE's, then fit the TE's to ribs S6 and S2 previously pinned to the building board.

During the next step make certain the **jig tabs on the ribs are contacting the building board and the ribs are perpendicular to the building board.**

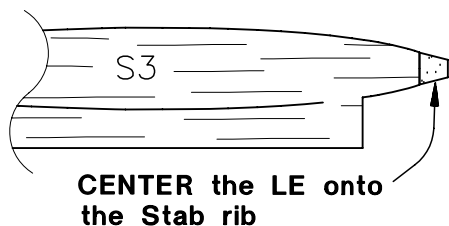

□ 7. Vertically centered, glue one of the stab LE's to ribs **S6** and **S2**, then do the same with the other

LE. Glue both TE's to all the ribs then glue the rest of the ribs to the LE.

□ 8. Use thick CA to glue the TE joiner to the TE's **making sure the jig tabs on the ribs are contacting the building board.** Wipe away excess glue between the TE's.

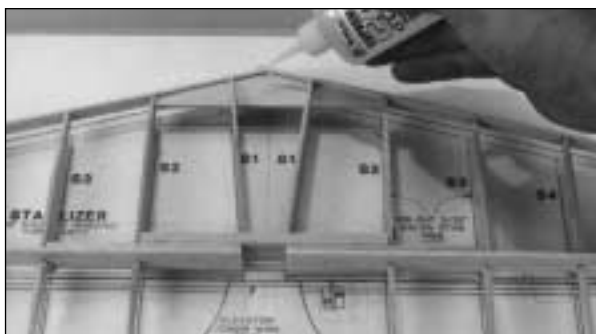

□ 9. Trial fit both **S1** ribs **without** the die-cut 1/8" plywood **LE Joiner**. After any required adjustments have been made to the S1's, trial fit them **with** the LE joiner. Make further adjustments if required then securely glue the assembly in position. Use CA to reinforce any glue joints that don't look strong.



□ 10. Prepare the top of the stab for sheeting. Use a razor plane and a sanding block to trim the top surface of the LE (particularly toward the tip) until it is even with the ribs. Sand the TE to smoothly blend with the ribs. The stab frame may be removed from the building board for this step but must be repinned to the flat building board to apply the skins.



## HOW TO MAKE WING AND STAB SKINS

(Also see additional Hot Tip on page 34)

A. Wherever practical, prejoin the balsa sheets to make a "skin" before attaching them to the structure.

B. Many modelers like to sort the wood so they can put the **best** wood with the most even grain structure on the **top** of the wing and stab.

C. Make your skin larger than needed to allow for misalignment. On a large surface like the wing, 3/8" extra is suggested.

D. To make skins, the following steps are suggested:

1. True up the edges of the sheets with a metal straightedge and a sharp hobby knife or an Easy-Touch Bar Sander.

2. Test fit the sheets together to make sure they match well.

3. Method "A": The fastest method for gluing the sheets together is with thin CA over a flat surface covered with waxed paper. A quick wipe of the joint with a fresh paper towel will remove most of the excess glue and make sanding easier. Mark the poorest surface with an "I" as the inside of the sheet.

Method "B": An alternate method for gluing the pieces that make up a stab or fin skin is to glue them together with aliphatic resin (white glue). Aliphatic resin sands much easier than CA so your skins won't get too thin from over sanding. Use masking tape to hold the sheets together until the glue cures – usually in about thirty minutes.

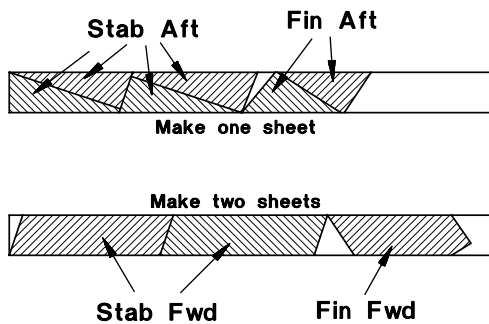

❑ 11. Make the skins for the stabs and fin using three 1/16" x 3" x 36" balsa sheets. See the sketch for the correct layout on the sheets. Refer to the plans for the exact shapes and sizes but remember to cut the sheets slightly oversize.

**Note:** The grain direction of the skins is *parallel* to the leading edges of stab and fin.



❑ 12. Cut a 2-1/2" wide cross-grain strip from one of the 1/16" x 3" x 36" balsa sheets used for the stab and fin skins, cut it to fit, then glue it between the S1 stab ribs.

**Caution:** If you have recently used any CA Accelerator on the structure during previous steps, be aware that residual accelerator may cause the thick or medium CA you may use during the next step to harden prematurely. Some modelers prefer to glue the skins to the structure with aliphatic resin. Use T-pins to hold the skins in position until the glue cures.



❑ 13. Be certain you can remove the stab from the building board after you glued the skins on. Apply an even bead of medium or thick CA to the upward facing edges of the structure. Place a skin in its proper position and press it down firmly until the glue has set. Repeat this step for the other top skin.

❑ 13. Use the template provided on the wing plans to cut four **Elevator Skins** from a sheet of 1/16" x 3" x 36" balsa.

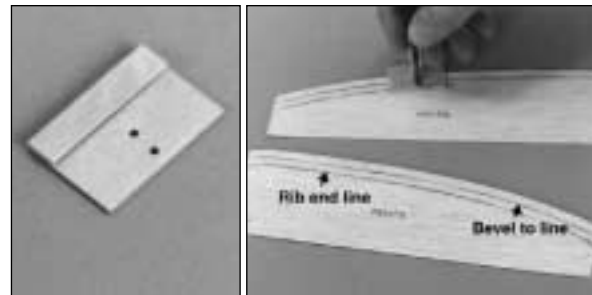

❑ 14. Build the **Bevel Gauge** from the die-cut 1/16" plywood then drill a #48 (or 5/64") hole at each punch mark. Use the gauge with a ball-point pen to mark the **bevel** and "**rib end**" indication lines on the **inside** surfaces of the elevator skins. **Make rights and lefts.**

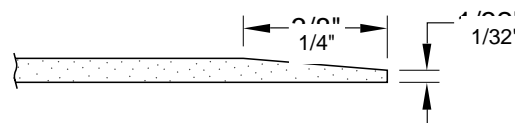

❑ 15. Use your Easy-Touch with fresh 150 or 220-grit sandpaper to bevel the aft 1/4" of the elevator skins (indicated by the aft line drawn with the gauge) down to roughly 1/32".



❑ 16. Glue the die-cut 1/8" balsa **Elevator Leading Edges** to the notches in the ribs then glue the bottom elevator skins in position. **Note:** Be sure the LE's are parallel to the stab TE. **Hint:** A stick will serve as a lever to push up the elevator skin to the elevator leading edge while you are gluing it.

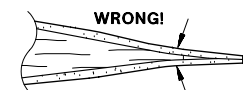
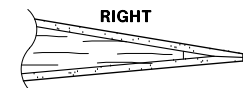

Do not pinch the skin together at the trailing edge.

❑ 17. Glue the top elevator skin in position. Weights placed on the stabilizer will help hold it to your flat building board to assure a straight, true stab and elevators.

❑ 18. Carefully remove the stab and elevators from your building board. Remove the jig tabs and use a razor saw to separate the elevators from the stab. Use an Easy-Touch loaded with 220-grit sandpaper to blend the ribs to the trailing and leading edges of the stab to prepare the structure for the bottom skins.

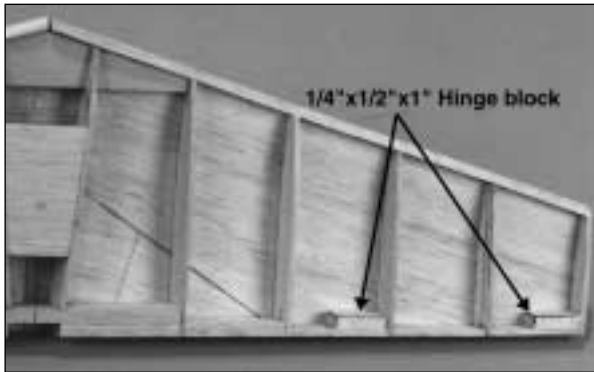

❑ 19. Cut another piece of 1/16" cross-grain sheeting 2-1/2" long and glue it between the S1 ribs as you did in step 12. Add four 1/4" x 1/2" x 1" **Hinge Blocks** to the inside of the stab trailing edged as shown in the plans. The outer hinge blocks will need to be trimmed to match the height and contour of the stab TE.

❑ 20. Inspect all glue joints and add CA where necessary. Glue the bottom stab skins just as you did the top. A good glue joint here is important, so apply a generous bead of thick or medium CA to all the upward facing edges of the structure. **Remember: Residual accelerator can cause the CA to cure prematurely.** Be careful not to add any twist in the stab as you apply the skins.



❑ 21. Use a sanding block to true up the tips of the stab and elevators and to remove the remnants of the ribs from the leading edges of the elevators and the trailing edge of the stab. **IMPORTANT:** Round the LE of the stab to match the **cross section** on the plan.

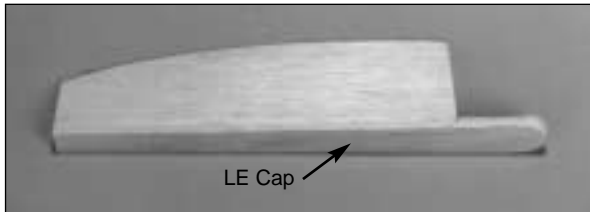

❑ 22. Glue a 3/16" x 1" x 11-7/8" balsa **Leading Edge Cap** to each elevator LE then trim to match the length of the elevator LE. Use a razor plane, then a sanding block to blend the top and bottom of the leading edge cap to the skins. Round the inboard ends to match the elevator LE.

❑ 23. Tack glue three 1/32" scrap plywood shims to the leading edge of each elevator, then tack glue each elevator to the stabilizer with a drop of CA on the shims. Make sure the outboard tips are flush by sanding the edges with a sanding block if required.



❑ 24. **Noting their orientation on the plans,** glue the shaped 5/8" thick balsa **Stabilizer Tips** simultaneously to the stab and elevator.

❑ 25. Use a razor plane and a sanding block to shape and round the tips. Refer to the cross section on the plans frequently during this process.



### SHAPING BALSА BLOCKS

The long carving blade in a heavy duty handle (A) is the best tool to create the rough shape as a large amount of wood can be easily removed. Once the blocks are "roughed in," use a razor plane (B) to fine tune the shape. Finally, #50 coarse, #150 medium and #220 fine sandpaper on an Easy-Touch Bar Sander will smooth out the lines and flat spots. Don't try to shave too much wood at one time and inspect your progress frequently. You can always remove wood, but it's difficult to put it back.





❑ 26. Separate the elevators from the stabilizer by cutting the tips with a razor saw and breaking away the tack glued 1/32" plywood shims.

**Hint:** Hold the razor saw close to the leading edge of the elevators while cutting. Use a long sanding block and 150-grit sandpaper to true the tips with the leading edges of the elevators and the trailing edges of the stabilizer.



❑ 27. Glue the shaped 7/8" thick balsa **Elevator Root Blocks** to the elevators then use a razor plane and a sanding block to shape them as you did the tips.

❑ 28. Draw **centerlines** on the leading edge of the elevators and on the trailing edge of the stabilizer. Mark the position of the hinges on the elevators and stabilizer using the locations on the plans as a guide.



**HOT TIP**

**DRAWING CONTROL SURFACE CENTERLINES**

1. Accurately measure the center point at the two extreme ends of the surface to be marked.
2. Insert a T-pin at each of the marks.
3. Hold a straightedge against the pins, then draw the centerline.

❑ 29. Cut the hinge slots now and temporarily install the hinges. Refer to the detailed hinging instructions on page 48. **NOTE: Do not glue the hinges yet, but wait instead until after the model is covered.**

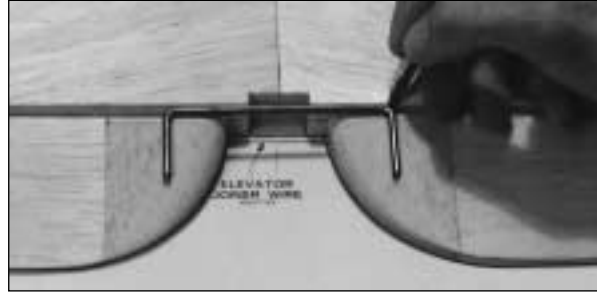
❑ 30. Sand the elevator LE's to a "V" shape to allow for the elevator travel (see the stab cross section on the fuse plans).



❑ 31. Hold the bent 1/8" **Elevator Joiner Wire** up to the elevators and mark the location of the holes (see the plans). Remove the elevators from the stabilizer and drill 1/8" holes in the elevators to accommodate the joiner wire.

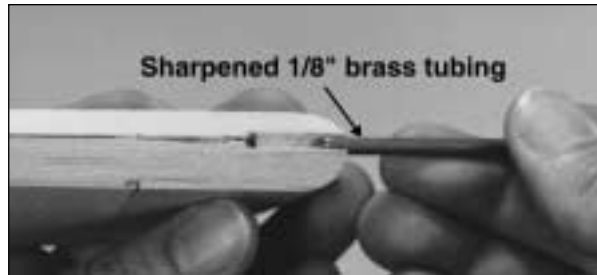

❑ 32. Make slots inboard of the holes to allow the wire to be inserted into the elevators. **Hint:** A piece of 1/8" brass tube sharpened at one end makes a great gouge for cleanly removing material from the leading edge of the elevators. Trial fit the stabilizer to the elevators with the joiner inserted and confirm that the elevators align with each other. Make adjustments if required.

❑ 33. Mark the location for the 1/8" x 7/8" x 1" plywood **Elevator Horn Block** on the bottom of the right elevator. Remove material as needed to allow the horn block to fit flush with the surface of the elevator.



❑ 34. Glue the elevator horn block to the elevator, then sand it so the pieces blend together.

## ***BUILD THE FIN AND RUDDER***

The Fin and Rudder are built simultaneously just the same as the stabilizer.

❑ 1. Remove the die-cut 3/32" balsa ribs **V-1** through **V-5** and **R-1** and the die-cut 1/8" balsa **Fin TE's** and **Rudder LE**. Be sure to preserve the jig tabs.

❑ 2. Cut the fin leading edge to the **exact length** shown on the plans from a piece of 1/4" x 11-7/8" tapered balsa stabilizer LE stock. Notice that the fin LE fits into a notch on top of F-9.

❑ 3. Slightly bevel the front edge of the ribs to match the angle of the leading edge stock.



❑ 4. Cover the rudder and vertical fin portion of the plans with waxed paper. Lay the leading edge on the plans and mark the exact location of rib V-1 directly on it with a pen. Pin only ribs **V-1** and **V-5** to the building board over the plans. Vertically center the LE on the front of the ribs and glue it in place.

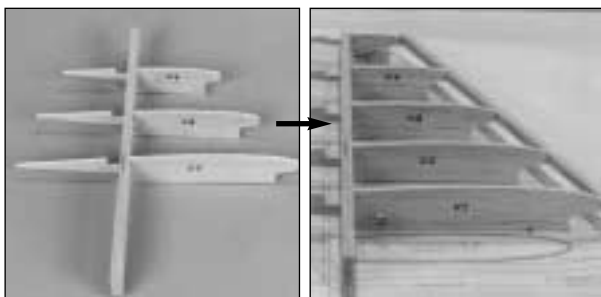

❑ 5. Laminate the two fin trailing edges to each other with thick CA. Place the remaining ribs in the notches of the fin trailing edge, **but do not glue them yet**. Fit the assembly to the parts already on the building board.

❑ 6. With **all jig tabs contacting the building board** and the ribs vertical, glue them to the leading edge and the trailing edge.

❑ 7. Use a sanding block and 150-grit sandpaper to blend the LE and TE to match the ribs on the upward facing (right) fin side.



❑ 8. Make a skin for each side of the fin using the 1/16" balsa sheet left over from the stab skins. Make them longer than required so they extend past V-1 about 5/8"; this will allow fitting to the stab later. With the structure flat on the table, glue on the right skin.

❑ 9. Trial fit the rudder LE to the notches in the ribs and make adjustments if necessary. Glue the rudder LE to the ribs.



❑ 10. Trial fit **R-1** to the notch in the rudder leading edge. Make sure it is square with the rudder leading edge and in line with the other rudder ribs, then glue it in position.

❑ 11. Use the templates provided on the plans to make two **Rudder Skins** from a 1/16" x 3" x 36" balsa sheet. Use the bevel gauge to mark the lines on the inside of each rudder skin, then sand the bevel just the same as you did on the elevator skins.

❑ 12. Glue the left rudder skin to the ribs and leading edge of the rudder.

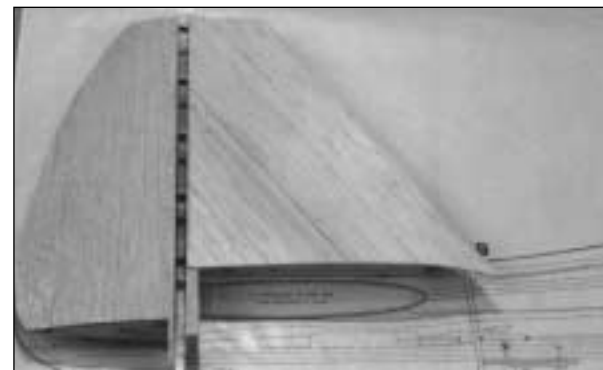

❑ 13. Glue the right rudder skin in position.

❑ 14. Remove the assembly from the building board and use a razor saw to separate the rudder from the fin. Remove the jig tabs from the fin and blend the leading and trailing edge to the ribs to prepare for the left side sheeting.

❑ 15. Glue the left fin skin to the fin.

❑ 16. True up the edges of the sheeting on both the fin and rudder with a sanding block. Shape the LE of the fin to match the cross section on the plans.

❑ 17. Glue the shaped balsa **Rudder Base** and the 1/4" x 1" x 11-7/8" **Rudder LE Cap** to the rudder. Trim the LE cap to the length shown on the plans and roughly shape the rudder base to blend it with the rest of the rudder. Don't completely round the bottom of the rudder yet as this will be done when it can be fitted to the fuselage.

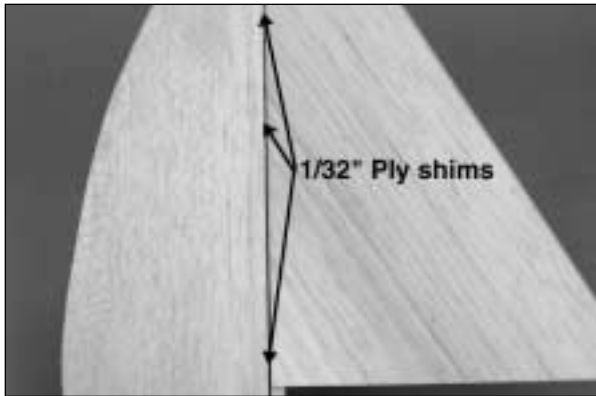

❑ 18. Tack glue or tape the rudder to the fin with three 1/32" plywood shims (as we did with the elevators). True up the tip of the fin and rudder if necessary, then glue the shaped 5/8" balsa **Fin Tip** simultaneously to the fin and rudder.

❑ 19. While the rudder and fin are still joined, use a razor plane and a sanding block to final shape the tip according to the plans. After shaping the tip, separate the rudder from the fin by cutting the tip with a razor saw and breaking off the plywood shims.

❑ 20. Draw a centerline on the leading edge of the rudder and the trailing edge of the fin, cut the hinge slots, then sand the "V" on the leading edge of the rudder.



❑ 21. Mark the location of the 1/8" x 7/8" x 1" birch ply **Rudder Horn Block** on the rudder. Remove balsa from the marked area, then glue the horn block in position. Sand it to blend to the shape of the rudder.

*Now you have a couple of nicely finished, lightweight, yet strong "tail feathers". That's pretty much the way the rest of the P-47 builds; rather "matter-of-factly." Before you know, it you'll have a beautifully-constructed piece of workmanship to admire.*

## BUILD THE FUSELAGE

### TOP FRAME ASSEMBLY

**NOTE:** The die-cut 1/8" plywood formers are stamped only with an abbreviated portion of their name. For example, **F-2B** is stamped **2B**. You may remove all the formers before you begin construction of the fuselage or you can remove them as you need them. Lightly sand each former to remove any die-cutting imperfections, slivers or irregularities before gluing it in position.

**IMPORTANT: All formers must be installed with the stamped identification number facing forward.**

❑ 1. Pin the **top view** of the Fuselage plan to a flat building surface, then cover it with waxed paper.

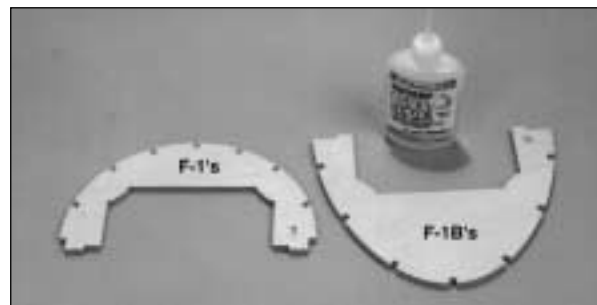

❑ 2. Use thick CA to laminate the **F-1's** together and the **F-1B's** together.

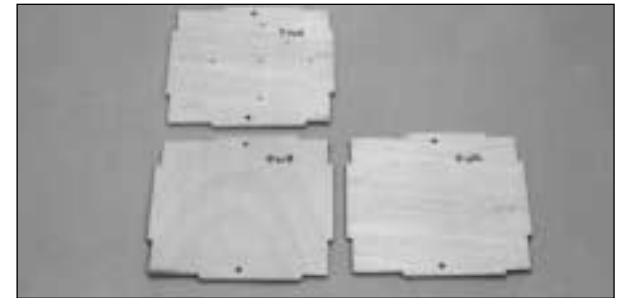

❑ 3. Drill a 1/16" hole in the five engine mount alignment punch marks in **FWA** and a 1/8" hole through each of the two firewall former alignment punch marks in **FWA**, **FWB** and **FWC**.

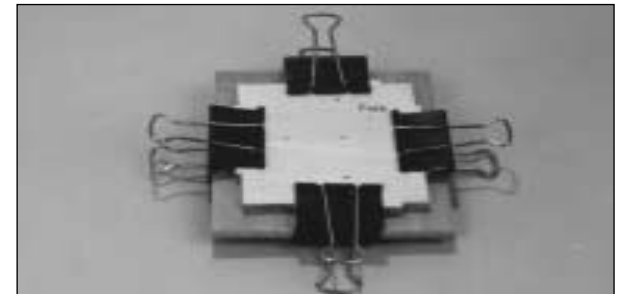

❑ 4. Cut the 1/8" x 1" **Alignment Dowel** in half. Use 30-minute epoxy to laminate FWA, B and C with the alignment dowel inserted in the holes. Make sure the stamped label on each former is facing forward. **Hint:** Clamp the firewall formers to a flat table or board to assure a warp-free firewall.

❑ 5. Remove 4" from each 3/16" x 3/8" x 48" **Shaped Main Stringer**, then pin them to the plans with the groove facing outward. Leave excess material extending beyond F-1 (it will be trimmed later). Accurately match the aft end to the plans.

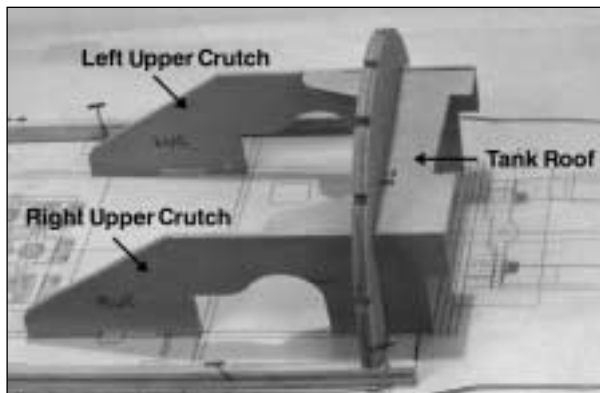

❑ 6. Fit, but do not glue, the **Tank Roof (TR)** followed by the **Right Upper Crutch (RUC)** and **Left Upper Crutch (LUC)** into former F-1. Place the assembly in its location on the plans between the main stringers. **Note:** Left crutch is slightly longer than the right crutch to set the engine thrust angle.

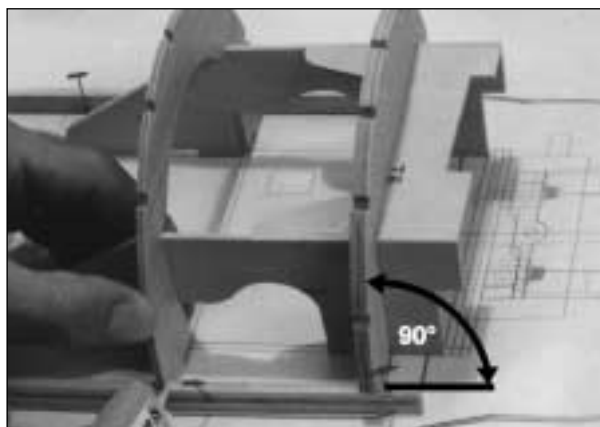

❑ 7. Fit former **F-2** to the upper crutches. Making sure F-1 is perpendicular to the building board, use medium CA to glue the **TR, RUC** and **LUC** to the **aft side only** of F-1. Later we'll glue the parts to the front of F-1 with a fillet of epoxy. **Do not glue the TR to the upper crutches forward of F-1.** Glue F-1 and F-2 to the side stringer and glue F-2 to the crutches.

**NOTE:** From this point on you will encounter a few areas on the structure that may be difficult to glue because they are not easily accessible. At this early stage much of the structure only needs to be tack glued, but it can be reinforced with thick or medium CA after the sheeting is applied and the frame is removed from the building board.

❑ 8. Drill 3/16" holes through the punch marks in formers **F-7** and **F-8**. With the numbers facing forward, glue the remaining formers **F-3** through **F-9** to the side stringers.

**NOTE: Use a small triangle to hold ALL formers vertical while gluing. Any small warps or twists will be taken out when the 3/16" stringers are glued in later.**

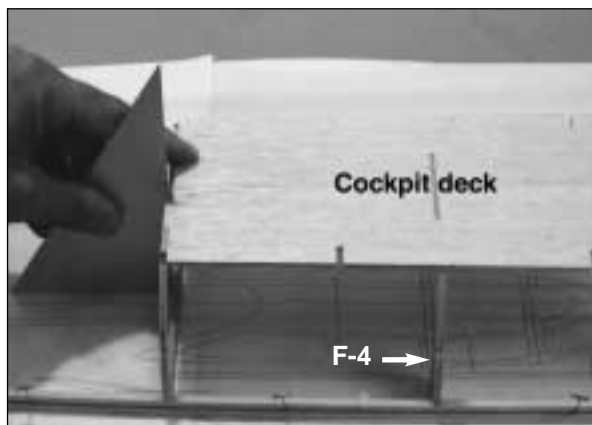

❑ 9. Glue the two halves of the die-cut 1/8" balsa **Cockpit Deck** together, then glue it to formers F-3, F-4 and F-5. **NOTE:** If you will be installing the Top Flite Scale Cockpit Interior, do not glue the cockpit deck to F-4.

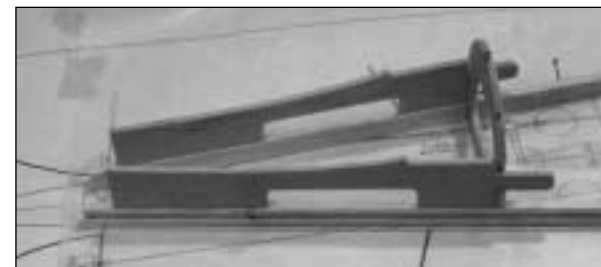

❑ 10. Glue the die-cut 1/8" plywood **Stab Saddles** to F-9 and the side stringers. **Note:** The bottom edges of the stab saddles are not flush with the side stringer but set away from the outside edge slightly. Also, the tops of the saddles are canted toward each other.

#### RAZORBACK VERSION:

Perform steps 11, 12 and 13 only if building the Razorback version.



❑ 11. Glue the die-cut 1/8" plywood formers **IP, CB** and **5-C** to the cockpit deck and former tops **6-C** and **7-C** to their respective formers. **Hint:** If you have decided to install the Top Flite Scale Cockpit Interior, glue the IP to the cockpit deck from the front only and CB from the back only. Most of the cockpit deck will be cut flush with IP and CB.

**NOTE: Save all the unused portions of the 3/16" x 3/16" stringers used during construction of the fuselage.**

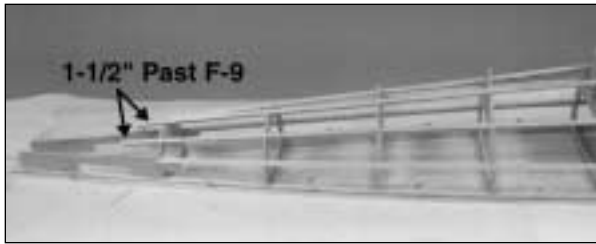

□ 12. Use a drafting triangle to hold the formers vertical and remove any twists as you glue one 3/16" x 3/16" x 42" balsa stringer in F-1 through F-9 on each side of the fuselage. Cut the stringers flush with F-1. Glue 3/16" x 3/16" x 24" stringers in the rest of the formers on the **aft end** of the fuselage. The middle stringer on each side extends past F-9 1-1/2" and will be trimmed to exact size later. The top 3/16" stringers end at the forward surface of F-9. **NOTE:** Do not glue the top stringers to F-9.

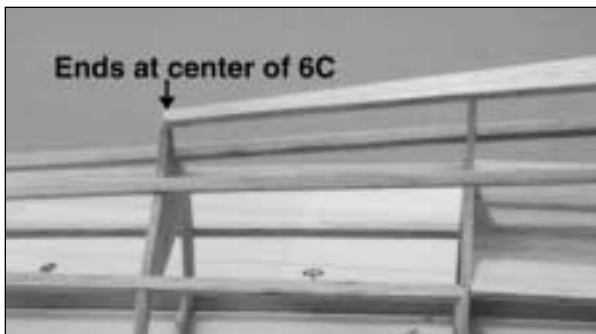

□ 13. Glue the die-cut 1/8" balsa **Razor Spine** to the top of CB, 5-C and 6-C. **NOTE:** The aft edge of the razor spine ends at the **center** of 6-C.

## BUBBLE CANOPY VERSION:

Perform steps 14 and 15 if building the Bubble Canopy version.

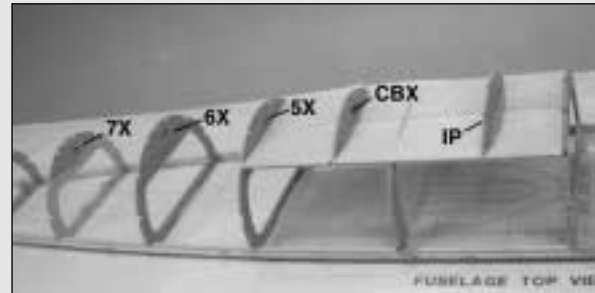

□ 14. Glue the die-cut 1/8" Plywood Formers **IP**, **CBX** and **5X** to the cockpit floor and former tops **6X** and **7X** to their respective formers. **Hint:** if you have decided to install the Top Flite scale cockpit, glue the IP to the cockpit deck from the front only and CBX from the back only. Most of the cockpit deck will be cut flush with IP and CB.

**NOTE: Save all the unused portions of the 3/16" x 3/16" stringers used during construction of the fuselage.**



□ 15. Use a drafting triangle to hold the formers vertical and remove any twists as you glue one 3/16" x 3/16" x 42" balsa stringers in formers F-1 through F-9 on each side of the fuselage. Cut them flush with F-1. Glue 3/16" x 3/16" x 24" stringers in the rest of the formers on the aft end of the fuselage **except for the top, middle stringer**. Notice the middle stringer on each side of F-9 extends 1-1/2" and will be trimmed to exact size later. The top 3/16" stringers end at the forward surface of F-9. **NOTE:** Do not glue the top stringers to F-9.



□ 16. Cut and glue the rest of the stringers for the front of the fuselage from three 3/16" x 3/16" x 24" balsa sticks.

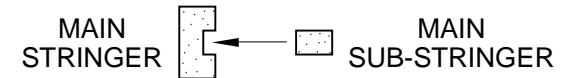

□ 17. Use thin CA (wiping away any excess before it cures) to glue two 1/8" x 3/16" x 24" balsa sub-stringers into the groove in each side main stringer. These sub-stringers will provide a ledge for the sheeting.

□ 18. Lightly sand all joints and blend the stringers to the formers in preparation for sheeting. Use a razor plane to bevel the edges of the cockpit deck.

## SHEET THE SIDES OF THE FUSELAGE TOP

□ 1. Locate the two shaped 3/32" balsa **Main Upper Fuselage Side Sheets**. The fuselage is longer than the sheet so we'll add a piece to the rear later. Refer to the plans for the position of the side sheet.

❑ 2. Wet the outside surface of a sheet and test fit it to the fuselage. **Hint:** a 50:50 mixture of water and rubbing alcohol applied to the outside surface will make the sheeting easier to bend. Make adjustments to the sheet if required.

❑ 3. Apply a bead of thick CA (remember the CA may cure on contact if there is any residual accelerator in the balsa wood) to the main side stringer and sub stringer then quickly place the sheet in position. Start from the middle and work outward inserting T-pins to hold the sheeting in place until the CA cures.

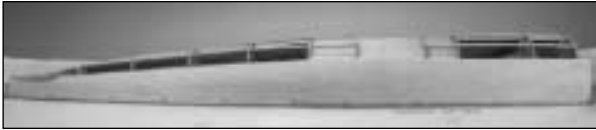

❑ 4. Glue the top of the side sheet to the stringers and cockpit deck with thin CA starting from the middle and working outward. Glue the sheet to the rest of the stringers and formers.

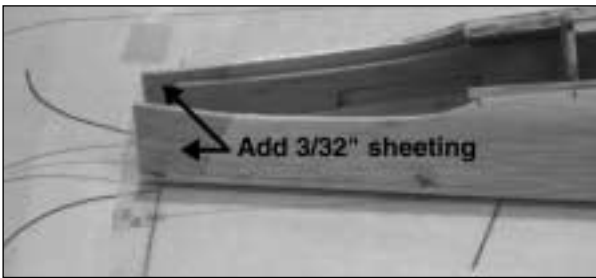

❑ 5. Glue the other sheet to the fuselage in the same manner. Add a piece of leftover 3/32" sheeting to the rear of each fuselage side.

## GLUE THE STABILIZER AND FIN TO THE FUSELAGE



❑ 1. Carefully trim the fuselage side sheeting until it is even with the plywood inner stab saddle. Make adjustments to the fuse sides very carefully so you **don't change the incidence angle** set by the inner stab saddle. If sanding is necessary, put masking tape over the inner stab saddles. Trial fit the stab to the saddle. Continue trimming the balsa side sheeting and the stringers that extend past F-9 until the stab contacts the entire length of the **plywood stab saddle**.



❑ 2. Remove the stab and trial fit the fin to the fuselage. A small piece of fin sheeting will need removed from the fin LE so it will fit in former F-9. The fin is in the correct position when the **front** of the fin trailing edge contacts the plywood stab saddle, the **bottom** of the fin trailing edge contacts the work surface and the fin LE fits all the way down into F-9. Study the fuselage side view. The trailing edge of the fin must be perpendicular to the work surface.

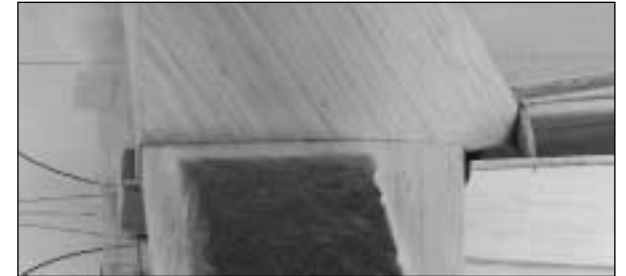

❑ 3. Place the stab onto the stab saddle, then trim the sheeting on both sides of the fin until it fits in the same position it was when you fit it without the stab.

**In preparation for gluing the stab and fin to the fuselage, make a "dry run" of the next few steps first without using any glue so you understand the procedure.**

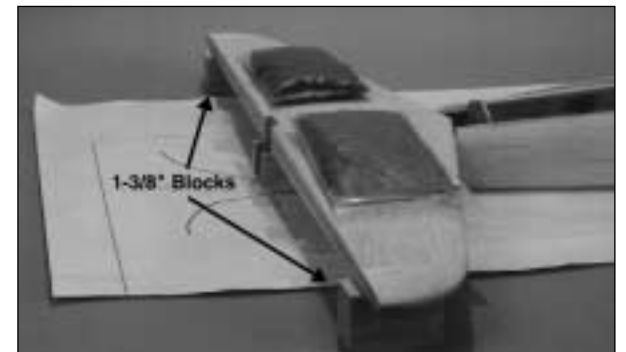

❑ 4. Put the stab on the saddle and add weights to hold it in place. Measure the height of each tip above the work surface and if not identical, make **small** adjustments to the saddle and fuse sides. **Hint:** Slide 1-3/8" balsa blocks (not supplied) under the tips and adjust their position to level the stab.

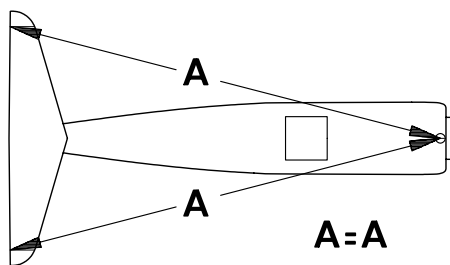

❑ 5. Use a string, pinned to the center of the top stringer at F-1, to equalize the distance of the stab tips to the nose. **Hint:** An alternate method to the “string and pin” technique, is to extend the line on the plans showing the trailing edge of the stab, then align the stab with this line. Use a pen and a straightedge to draw the line.



❑ 6. Accurately draw a centerline along the length of the fin post (or use the same centerline previously drawn for hinging). Fit the fin into the stab and fuselage, then clamp the rear of the fuselage sides together. Use a triangle to confirm that the fin is perpendicular to the work surface. When it's time to glue the fin to the fuse and stab, masking tape may be used to hold the fin in position while the epoxy cures.

❑ 7. Double check all alignments. Permanently glue the fin and stab in position with 30-minute epoxy.

### COMPLETE THE FUSE TOP RAZORBACK VERSION:

Perform steps 8 through 13 **only** if you are building the Razorback version.

However, if you are installing the optional cockpit kit (no matter which version you are building), skip ahead and perform steps 3 & 4 on page 21 before you glue the top fuse sheeting in position.



❑ 8. Trim the shaped 15" balsa **Fuselage Spine** to fit between the leading edge of the fin and the aft edge of the Razor Spine then glue it to the formers. Bevel the sides of the Razor Spine so it blends with the curvature of the formers. (See cross section on fuselage plan.)



❑ 9. Use the template on the plans to make a **Right** and a **Left Aft Fuselage Top** from two 3/32" x 3" x 30" balsa sheets. Start by fitting the bottom edge of one of the top sheets to the side sheet, on the fuselage. Position the top sheet on the fuselage and mark where it will be notched for the Razor Spine.



❑ 10. Cut the notch in the top of the sheet so it will fit against the Razor Spine and fuselage spine. Wet the **inside** portion of the sheet that bends inward towards the fuselage and wet the **outside** of the portion of the sheet that bends around the formers. **Hint:** The best way to make the sheeting conform to the compound curves of the Razorback is to liberally wet the sheet then place it on the fuselage and little by little bend it into position. Wet, then reposition the sheet on the fuselage a few times continuously bending it to shape each time. Let the sheet dry for a few minutes before permanently gluing it. Glue the aft top sheet to the fuselage.

❑ 11. Trim the top edge of the sheet where it meets the Razor Spine and fuselage spine. Glue the other aft top sheet to the fuselage in the same manner as the first.



❑ 12. Position the 1/2" x 1-1/4" x 8" **Aft Deck Top Block** on the Razor Spine and trace its outline. Carve the top block to approximate shape, then glue it in position.



❑ 13. Glue a 1-1/4" wide strip of 3/32" balsa to the cockpit sides joining the front deck. Refer to the cross section and side view on the plans then use a razor plane and a sanding block to blend the aft deck top block to the fuselage. Cut out the canopy and use it as a guide to accurately shape the top block.

### COMPLETE THE FUSE TOP BUBBLE CANOPY VERSION:

Perform steps 8-10 only if building the Bubble Canopy version.



❑ 8. Reference the cross section on the plans, then cut a notch in former F-8 for the top stringer. Trial fit the 3/16" x 3/16" x 24" stringers in the notches in the tops of the formers. The aft end will have to be shaped to fit between the stringers at former F-9. Glue the stringer in position.



❑ 9. Use the template on the plans to make a **Right** and a **Left Aft Fuselage Top** from two 3/32" x 3" x 30" balsa sheets. Wet the outside of one of the tops, then glue it to the top edge of the aft fuselage side and the stringers. Apply medium CA to the formers and top stringer, then roll the sheet into contact. Hold it in position until the CA cures.

❑ 10. Custom fit the other aft fuselage top then glue it to the other aft fuselage side in the same manner.

❑ 14. Cut the **Upper Forward Fuselage Tops** from a 3/32" x 4" x 30" balsa sheet. This should be done in two halves with the pieces joining in the center of the top middle stringer.



❑ 15. Wet the outside of an upper forward fuselage top to soften it, then place it on the upper forward frame. It should overlap the instrument panel and F-1 by about 1/8".

❑ 16. Glue the top to the fuselage. Cut the other side of the upper forward fuselage top to fit on the fuselage then glue it in position the same as you did the first piece.

### FINAL FIT THE CANOPY RAZORBACK VERSION

❑ 1. Use leftover balsa and the templates on the plans to make the 1/16" **Razorback Cockpit Fairings** and the 1/8" **Cockpit Fairing Formers**.



❑ 2. Set the canopy on the fuselage and mark the location of the cockpit fairing formers. Glue the formers to the fuselage.

❑ 3. Replace the canopy on the fuselage to confirm the position of the cockpit formers and test fit the cockpit fairings. Make adjustments if necessary, then glue the cockpit fairings in place.



❑ 4. Apply HobbyLite balsa filler around the fairings to blend them to the fuselage sheeting. Apply a couple of thin layers and sand between each application.

### FINAL FIT THE CANOPY BUBBLE CANOPY

❑ 1. Cut the bubble canopy to the trim lines scribed around its perimeter. Lightly sand the butyrate to smooth the edges.

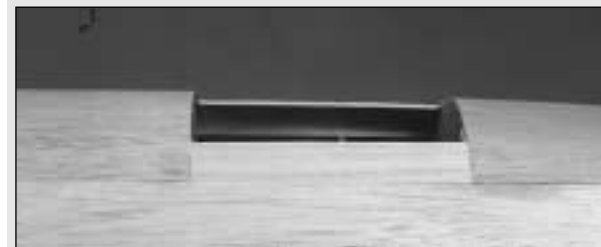

❑ 2. Fit and glue two pieces of leftover 3/32" balsa sheet between IP and the cockpit's aft former. These pieces should extend about 1" above the upper stringer as shown.

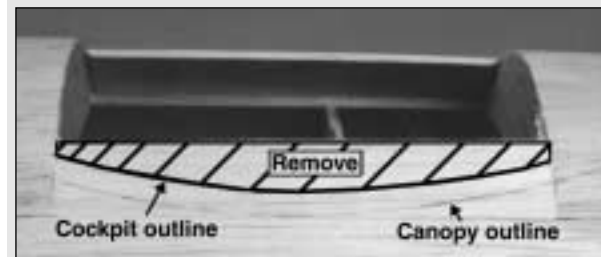

❑ 3. Refer to the plans for the canopy location, then position the canopy on the fuselage. Trace around the canopy to define its shape around the cockpit. Remove the canopy. Draw a second line parallel to and 1/4" above the first. Trim the excess balsa to match the **second** line.

## FINAL STEPS BEFORE FRAMING THE LOWER FUSE

❑ 1. Turn the fuselage over and reinforce all glue joints that don't look strong or that you couldn't reach before. **Do not glue the tank roof to the upper crutches forward of F-1 until told to do so.** Add a fillet of 30-minute epoxy inside the fuselage where the stab meets the plywood saddle. **Hint:** *An inexpensive Robart® Super Stand works well to support the fuse and because it's made of Styrofoam® and can be modified to conform to the fuse shape.*



❑ 2. Use model filler (Hobbico *HobbyLite* balsa-colored filler recommended) to **begin** blending the top deck with the stab and fin. Apply in thin layers allowing each layer to dry thoroughly before the next application.

Perform steps 3 & 4 only if installing the optional scale interior kit.

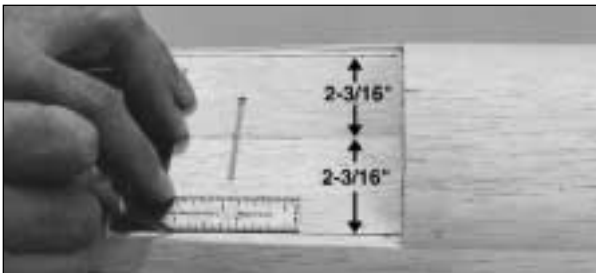

❑ 3. If you are going to install the Top Flite Scale Cockpit, remove the cockpit deck in the cockpit area. Measure 2-3/16" from both sides of the joint in the cockpit deck halves along the instrument panel (IP) and the cockpit back (CBX).

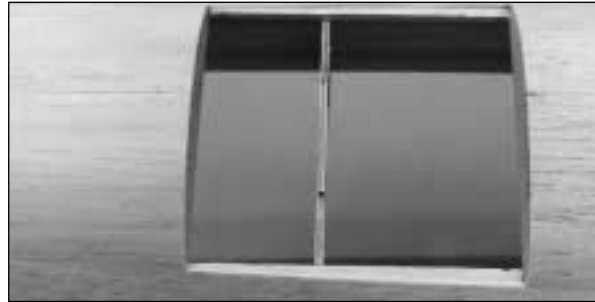

❑ 4. Cut out the cockpit deck close to IP and CB (CBX for Bubble Canopy) and along the lines 2-3/16" from the center. Sand the cockpit deck flush with the cockpit back and instrument panel. The top portion of F-4 will be removed later.

❑ 5. Apply masking tape to the bottom of the Stab and also the Fuse Side about 3/16" on either side of the joint. Mix a little 30-minute epoxy, then squeeze it into the Stab/Fuse joint. Remove the tape before the epoxy cures and feather the excess with your finger.

❑ 6. Once the epoxy has cured, apply more masking tape about 1/4" out from the joint, then use model filler to create a neat fillet along the length of the joint. Once again, remove the tape before the filler dries and feather the edges with your finger to avoid excessive sanding.

❑ 7. **NOTE: Protect the stab and fin skins with masking tape around where you will be sanding to avoid the possibility of dangerously thinning the skins.** Lightly sand the first layer of filler around the Stab and the Top Deck, then apply a second coat. When the filler is dry use different thickness dowels wrapped with 220-grit sandpaper to shape the fillet. *Take your time to blend all contours with the Fuse.*

## FRAME THE FUSE BOTTOM

❑ 1. Drill 3/16" holes through the punch marks in formers 4-B and 5-B.



❑ 2. Test fit the die-cut 1/8" ply **Left and Right Lower Crutches** to the formers in the fuselage then add the die-cut 1/8" formers **2-B**, both **3-B's**, **4-B** and **5-B** without gluing any parts. Make sure all the formers fit into the notches in the crutches and make sure the lower formers fit into the upper formers. Make adjustments if necessary.

❑ 3. Test fit **1-B** and **TF** to the crutch in the fuselage. Make sure 1-B fits well into former F-1. Make adjustments if necessary.



❑ 4. After any required adjustments have been made, use a straightedge to keep each lower former parallel to each upper former, then glue them together. **Double check that F-1B is parallel to F-1.** Glue the crutches to the lower formers. Glue the tank floor to the crutches and formers. **NOTE:** Do not glue the tank floor to the crutches **forward** of F-1B at this time.



❑ 5. After carefully aligning the holes, glue both **2-C's** to the forward surface of F-2B. Inspect all the glue joints and add small fillets of medium CA where each former meets the crutches.

❑ 6. Glue the remaining lower formers **6-B through 8-B** to their respective upper formers. Use a straightedge to maintain vertical alignment between top and bottom formers. **Hint:** For better bonding with the sheeting, lightly sand the formers edges so that they are slightly beveled to match the angle of the fuse toward the tail.

❑ 7. Drill a 5/64" hole through the two forward punch marks in the die-cut 1/8" plywood **Tail-wheel Deck (TW)** and a 9/64" hole through the aft punch mark. Insert **9-B** into **TW** and glue them to the fuselage as shown on the plans. Glue **5-D** to the crutches.



❑ 8. Glue three 3/16" x 3/16" x 24" stringers in the aft former notches; one in the bottom and one more in each middle notch as shown in the photo. **NOTE:** The two side stringers at former F-9 do not end at the aft edge of F-9 but are inset 1/16". Use a straightedge as you glue in the stringers to keep the formers in vertical alignment.



❑ 9. Test fit the die-cut 3/32" balsa **Wing Saddles** to the formers, then glue them in position.

### TAIL GEAR INSTALLATION

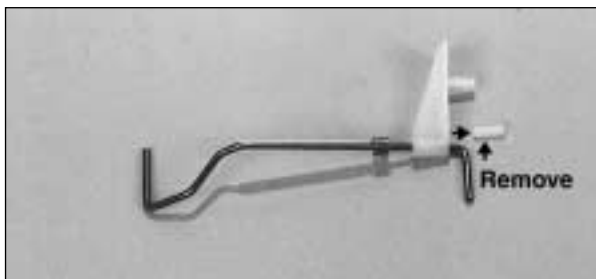

❑ 1. Cut the Aft Post flush with the nylon **Tail Wheel Bracket**.



❑ 2. Use a pliers to flatten 1/4" of one end of the 1/8" x 5/8" **Brass Tube**. Slide the tube on the **Tail Wire** and check the parts over the fuselage top view to make sure they match up well. Use silver solder to solder the brass tube to the top of the tailwheel wire.



### SILVER SOLDERING

Use this process when soldering metal to metal, such as brass tube to wire, or pushrod ends to wire.

A. Thoroughly clean the items to be soldered with alcohol or degreasing solvent. Pay special attention to the inside of the threaded brass couplers.

B. Roughen the area to be soldered with fine sandpaper, then clean again.

C. Assemble the items to be soldered.

D. Apply a small amount of soldering flux. Acid based liquid flux works best when one or more of the items is steel.

E. Heat the metal with a soldering gun or iron and apply solder to the metal. The metal must get hot enough to melt the solder and the solder must flow freely into the joint.

F. Do not move the parts until the solder has cooled.

G. Test the joint by pulling hard.

H. Clean off the excess flux with alcohol or solvent. Coat the parts with a very fine film of oil.

❑ 3. Mark the location of the **Metal Ball** on the end of the brass tube and drill a 1/16" hole at the mark.

❑ 4. Attach the ball permanently to the tail gear with the **Small Nut** provided. Put a drop of epoxy on the threads to prevent it from coming loose.

❑ 5. Use the **4-40 Set Screw** to lock the **Collar** at the height shown on the fuselage side view, but orient the set screw so small adjustments can be made later during construction if required.

❑ 6. Roughen the tubular **Nylon Bearing** on the tailwheel wire with coarse sandpaper.

❑ 7. Cut two 3" long sticks from one of the approximately 6" long scrap pieces of 3/16" x 3/16" stringers leftover from the top of the fuselage. Bevel one end of each stick, then glue **one of them** to the side of middle stringer on the very bottom of the fuselage. The other one will be glued on at step 11.



❑ 8. Place the tailwheel assembly on the tailwheel brace with the nylon bearing tube next to the stringer. Mark the location with a pen then cut a notch in the stringer for the nylon bearing.

❑ 9. Test fit the tailwheel assembly with the bearing in the notch. Rotate the tailwheel wire and check for binding. Make adjustments if necessary.

❑ 10. Put a few drops of 30-minute epoxy in the holes of the plywood tailwheel brace and the bolt holes of the nylon bracket. Screw the nylon bracket to the brace with two **#4 x 3/8" Sheet Metal Screws**.

❑ 11. Force some epoxy into the notch of the stringer and around the nylon bearing being careful not to get any epoxy inside the tube. Glue the remaining 3/16" x 3/16" x 3" stick to the other side of the stringer to lock the nylon bearing into position.

❑ 12. Cut the .074" x 36" **Threaded One End Rod** to approximate length by removing 7" from the non-threaded end. Thread a **Dual-Ended Ball Link** 14 full turns onto the threaded end.

❑ 13. From the 6-1/2" long piece of inner pushrod tube, cut 11 pieces approximately 3/8" in length and slide four of them onto the rudder pushrod, spaced as shown on the plans.



❑ 14. Mark and cut the rudder and elevator pushrod exits where shown on the fuselage plans. Bevel the exits with a sharp knife or a round file to allow the outer pushrod tubes to exit at the angle shown on the plans.

❑ 15. Place two 36" long grey **Outer Pushrod Tubes** over the **Elevator Pushrod Tube** and **Forward Rudder Pushrod Tube** drawings on the top view of the fuselage plans. Cut them a few inches longer than length shown. Use 220-grit sandpaper to roughen the outside of the tubes so glue will stick to them.

❑ 16. From one of the short cut-off pieces of 36" pushrod tube, cut a 5" long piece for the **Aft Rudder Pushrod Tube** and sand the outside.

❑ 17. Slide the forward rudder pushrod tube and the elevator tube through the holes in the formers and position them as shown on the plans with the excess length forward of F-4 **Note:** Remember you are looking at the top view of the plans. Position the pushrods on opposite sides of the fuse, when looking at the fuse from the bottom.

❑ 18. If you haven't already done so, cut the rudder hinge slots. Temporarily install the rudder onto the fin.

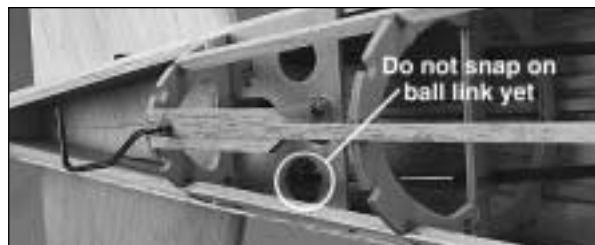

❑ 19. Install the **Forward Rudder Pushrod** through the slot in the rear of the fuselage. Position the dual-end ball link on the ball **but do not snap it on yet**.

❑ 20. Thread a **Nylon Clevis** onto the .074" x 12" pushrod then place it over the Aft Rudder Pushrod drawn on the plans and cut it **1/8" longer** than shown.



❑ 21. Temporarily snap a **Small Control Horn** onto the clevis and slide a **Threaded Coupler** on the end of the rod. Slide the control rod through the pushrod exit in the aft end of the fuselage and place the control horn on the rudder in the position shown on the plans.

❑ 22. Observe the location of the threaded coupler and see if the length of the pushrod is correct. **With the rudder and tailwheel in neutral position the threaded rod should be able to screw into the dual-end ball link about 3/16"**. Make adjustments to the length of the pushrod if required.

❑ 23. Once the threaded coupler is soldered to the pushrod and the system is hooked up and closed in, some adjustment may be made by screwing or unscrewing the clevis but the more accurate it is now, the less adjustment you may have to make later. Slide one of the 3/8" spacers onto the aft rudder pushrod, then use silver solder to solder the threaded coupler onto the pushrod.



❑ 24. Bevel the aft rudder pushrod tube so it matches the angle of the fuselage. Install **but don't glue** the tube in the pushrod exit, then cut the forward end so it extends 1/8" past the slot in the plywood stab saddle.

❑ 25. Slide the aft rudder pushrod through the aft pushrod tube temporarily mounted in the fuselage. Confirm that the alignment and location of the pushrod and tube is correct. Make adjustments if necessary, then permanently glue the aft pushrod tube to the fuselage.

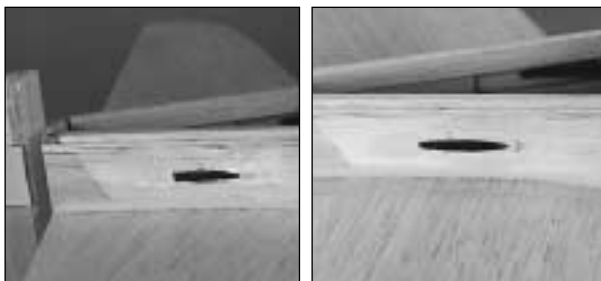

❑ 26. Prior to permanently connecting the aft rudder pushrod, fill any gaps where the pushrod tube exits the fuselage with some Micro Balloons (Top Flite recommended) and epoxy. After it cures, final sand to make a smooth, clean pushrod tube exit.

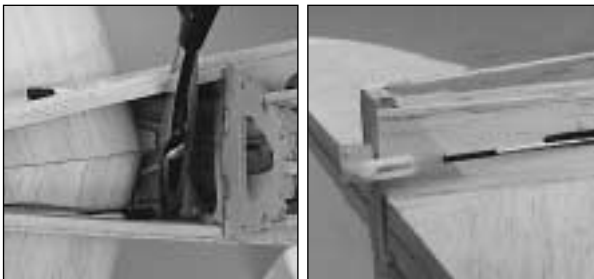

❑ 27. Permanently install the aft rudder pushrod. Hold the dual-end ball link with a pliers and screw in the aft pushrod. Check the length of the rod, and how far it is screwed into the dual-end ball link. Make adjustments if required. Snap the ball link onto the ball.

### ***FIT THE INTERCOOLER AIR EXITS***

**NOTE: If you have decided to install the supplied vacuum formed intercooler air exits, follow the instructions below. If you elect not to install the exits or wish to represent them in a closed position, follow only step 6 and 7 below. Then, the closed air exits would simply be represented by panel lines on your finished model.**

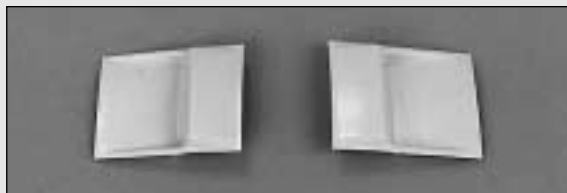

❑ 1. Cut out the right and left vacuum formed intercooler air exits along the cut lines.

❑ 2. The main side stringers between F-6 and F-7 need to be inset to clear the intercooler air exits before adding the bottom sheeting. Mark the location of the air exits on the fuselage side stringers where shown on the plans.



❑ 3. Hold an air exit up to the side stringer, then use a ball-point pen to mark where the side stringer interferes with it. Use a razor saw to carefully cut through the side stringer and sheeting. Remove this piece from the fuselage. Perform this step on the other side of the fuselage.

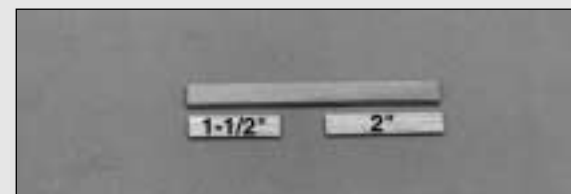

❑ 4. Glue a 1-1/2" long strip of 1/16" sheet to one end of the 1/8" x 3/8" x 4-1/4" plywood strip and a 2" long piece to the other end. Make two of these assemblies.



❑ 5. Glue the main side stringer **Braces** to the inside of the main side stringers. Refer to the top and side view of the fuselage plans for location.

❑ 6. Glue the remaining four 3/16" x 3/16" x 24" aft fuselage stringers to the notches in the formers.



❑ 7. The stringer below the main side stringer (above, if the model is upside-down on your cradle) also must be spliced in order to clear the intercoolers. Cut a section out of the stringers directly above the main stringer.



❑ 8. Cut leftover 3/16" x 3/16" stringers to reinforce the stringers you notched to clear the intercooler air exits.

### ***SHEET THE FUSE BOTTOM***

❑ 1. If you haven't already done so, glue the remaining four 3/16" x 3/16" x 24" aft fuselage stringers to the notches in the formers.



❑ 2. Use a 3/16" x 3/16" x 24" stringer to make the two aft stringers from F-9 to the rear of the fuselage.

❑ 3. Use a sanding block and 150-grit sandpaper to blend the stringers to the formers and eliminate any glue blobs or irregularities. Even up the stringer ends with the formers.

❑ 4. Cut two **Lower Fuselage Sheets** from 3/32" x 3-1/4" x 42" balsa to match the pattern on the plan. The cut sheets will be slightly oversize to allow for final fitting and sanding.



❑ 5. Test fit the sheet to the fuselage and make adjustments by carefully shaving away wood where needed. Trim the sheeting between F-9 and F-5D to fall on the **centerline** of the 3/16" Stringer. Aft of F-9 the sheeting is even with the bottom edge (top if fuselage is upside down) of the stringer.

❑ 6. Position the side sheet on the **Main Stringer ledge**. Press the sheet against the Main Stringer and wick thin CA into the joint, from the **inside**. Start at the center and work forward and aft, **tack gluing** the sheet in place as you proceed. When the length of the sheet has been tacked in place, go back and wick thin CA along the entire inside edge.



❑ 7. Bend the sheet into contact with the aft stringer then wick thin CA into the joint—from the center outward. If the balsa sheet is too rigid, use water on a paper towel to moisten it. Finish attaching the sheet by wicking CA into all former and stringer joints along the sheet. Wipe any excess CA from exposed edges before it cures.

❑ 8. Add a piece of scrap 3/32" balsa to the aft end of the sheet.

❑ 9. Repeat steps 3-6 for the opposite side.



❑ 10. Use two 3/32" x 4" x 30" balsa sheets to cover one side of the aft bottom of the fuselage. Wet the outside of the first sheet to help it bend around the formers. When satisfied with the fit, glue it in place with medium CA. Sheet both sides. Wick thin CA along the top joint.

- ❑ 11. Trim the ends of the aft bottom sheeting even with F-9 and F-5D.



- ❑ 12. Use a sanding block to sand the aft fuse sheeting flush with the stringers so it tapers to the bottom edge of the fin post.

- ❑ 13. Bevel the front edge of the 1" x 2-1/2" x 7" **Aft Fuse Block** to fit flush against 9-B. Sand the aft edge flush with the fin post.



- ❑ 14. Put the block on the fuselage and trace around the underside and forward edge to form a rough cutting outline. Tape the rudder in position so that you can trace the outline on the aft edge of the block.

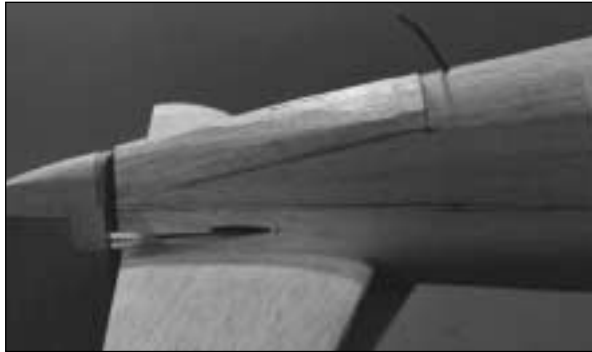

- ❑ 15. Remove the block, then use a hobby knife and a razor plane to carve the shape to match the outline you traced. Glue it in position when satisfied with the shape.



- ❑ 16. Continue shaping the aft fuse block to blend with the fuse. Temporarily install the rudder, then shape the aft fuse block and the rudder to blend smoothly with the fuse.

- ❑ 17. Use 30-minute epoxy to glue the 1/2" x 7/8" x 1-1/4" **Maple Wing Bolt Blocks** in the fuselage at the location shown on the plans.

**Note: We will sheet between F-1 and F-2 when we finish sheeting the belly pan.**

## INSTALL THE ENGINE

There are a variety of options when it comes to engine selection. Our prototype P-47 weighed approximately 10 lbs and flew **extremely well** with the Super Tigre .75 2-stroke. When using a 1.20 4-stroke engine, due to the large amount of power

available the P-47 will have a tendency to climb as full power is applied. This condition can be controlled by adding an additional **one degree of down thrust to the engine.**

**NOTE:** The following sequence shows the installation of a Super Tigre .75 engine with the cylinder mounted at a 45 degree angle towards the bottom of the fuse. This orientation allows the exhaust port of a 2-stroke engine to be connected to a **Top Flite In-Cowl Muffler** and the engine exhaust to exit near the bottom of the fuse.

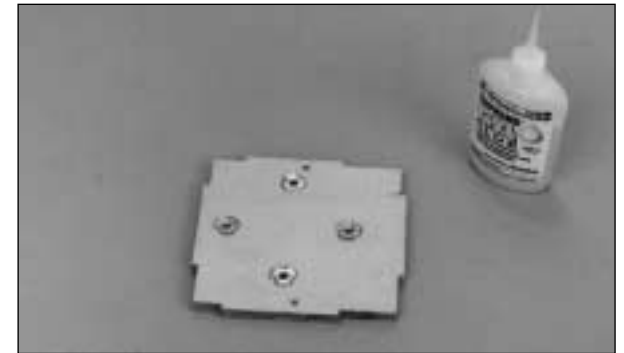

- ❑ 1. Drill four 7/32" holes through the laminated **Firewall** for the engine mounting bolts at the marked locations. Insert four 8-32 **Blind Nuts** into the holes from the **aft** side and seat them with **gentle** taps from a hammer. Wick thin CA around the flange of each nut to secure it in position. **Avoid getting CA into the threads.**

- ❑ 2. Remove the spacer bar from the back of both **Engine Mount Halves** and trim off any burrs. Temporarily bolt the engine mount to the firewall with four 8-32 x 1-1/4" **Socket Head Cap Screws** with #8 **Lock Washers** and #8 **Flat Washers**. Place the engine between the rails, adjusting the width of the rails accordingly.



## BUILD THE WING

**NOTE:** The wing panels are built “**UPSIDE-DOWN**” on the plans. The jig tabs are attached to what is, in the end, the **TOP** surface of the wing. Since it is the standard convention to show the Top View of the wing, and the wing panels are built upside down, the **LEFT** wing panel is built over the **RIGHT** Wing Top View and vice-versa. This does not present any problems; just be sure to build a left and a right wing.

### PREPARATION

❑ 1. Locate the four 1/4" x 3/8" x 36" hard balsa **Wing Spars**, then cut them 1/4" longer than shown on the plans. **Save** the cut-off ends for the flap servo hatch mounts.

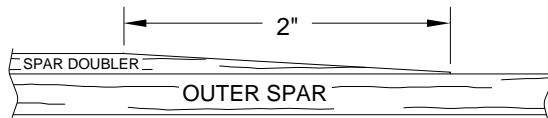

❑ 2. Sand a taper on one end of each of the four 1/8" x 3/8" x 18" balsa **Spar Doublers** as shown in the sketch. Laminate a spar doubler to each spar with the root end of the doubler aligned with the root end of the spar.

❑ 3. **Before** removing the 1/16" plywood **Dihedral Braces** from the die-cut sheet, draw a centerline on both pieces by connecting the punch marks.

❑ 4. Remove all the die-cut 3/32" balsa **Wing Ribs** and 1/16" ply (or 1/8" ply if installing fixed landing gear) **Rib Doublers**. Smooth out any imperfections with sandpaper. Be sure to keep the jig tabs attached to the ribs.

❑ 5. Ribs **W-2** through **W-6** have punch marks just aft of the spar. Drill a **3/16" hole** at each of these marks for future installation of the aileron pushrods.

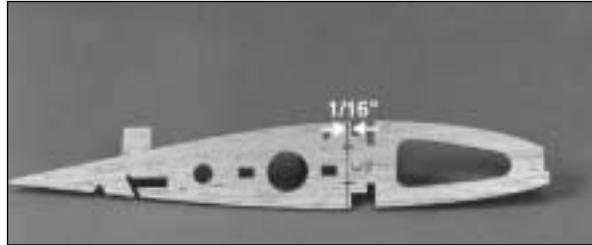

❑ 6. Use a straightedge to draw a line on either side of both W-2 ribs 1/16" behind the spar notch. Put marks on the line equal to the depth of the deepest part of the forward notches.

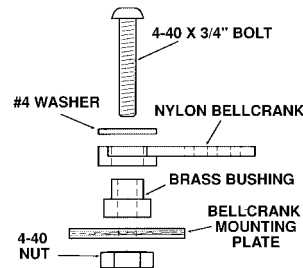
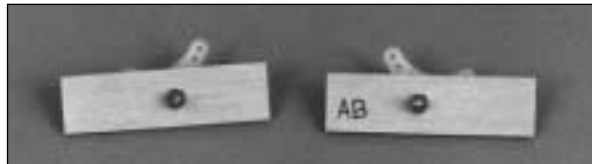

❑ 7. Drill 1/8" holes through the punch marks in the two die-cut 1/8" plywood **Aileron Bellcrank Plates (AB)**. Assemble the bellcrank parts as shown in the sketch (don't worry, there is no *right* and *left* – you can't build them backwards). Put a drop of 6-minute epoxy on the **4-40 nut and threads** to prevent the bellcrank from vibrating loose.

**NOTE:** If you haven't already done so, now is the time to decide if you are going to use retractable or fixed landing gear.



### Skip this step if installing retracts

❑ 8. Locate wing ribs **W-4**, **W-5**, **W-6** and plywood doublers **W4-F**, **W5-F** and **W6-F**. Use thick CA to glue the ribs and doublers together. Be sure to make a **LEFT** and a **RIGHT** of each rib assembly. Remove the shaded area with a hobby knife or razor saw.

### RETRACT MODIFICATION FOR CENTURY JET RETRACTS

The standard retract rail spacing in this kit is designed to accept Robart #606 85 degree retracts without modification. However, if you elect to install the Century Jet Model's retracts, modify the rails and rib doublers to accept the CJM retracts as follows. It will be easiest to do this before framing the wing while the ribs and doublers are easy to modify.

❑ 1. Use the sketch on page 55 to modify the 1/16" plywood rib doublers before laminating them to ribs W-5 and W-6.

❑ 2. Make four new retract rails from 1/4" thick **5-ply aircraft plywood**. The new dimensions should be 1/4" x 17/32" x 3-1/16".



**Skip this step if installing fixed gear**

- ☐ 9. Locate wing ribs **W-5** and **W-6**, and 1/16" plywood doublers **5-R** and **6-R** (4 each). Use thick CA to glue the ribs and doublers together. Remove the **shaded** area with a hobby knife or razor saw.

*Okay, the prep work is behind you, so now that the dull stuff is done, let's build the outer wing panels so you'll have something to show when your friends drop in to check on your progress!*

**BUILD THE WING PANELS**

- ☐ 1. Place a **Wing Panel** plan on a **flat** building board and cover it with waxed paper. *Cutting the wing panel sections apart makes handling easier.*

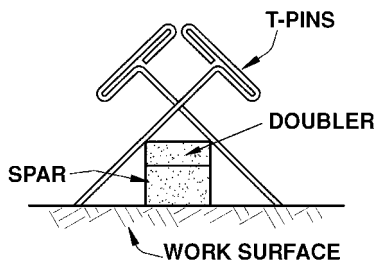

- ☐ 2. Pin a **Top Spar** to the building board at four or five locations using the cross-pinning technique shown in the sketch. The extra length should extend past the **root** end of the plan.



- ☐ 3. Position the die-cut 3/32" balsa ribs **W-2** through **W-11** on the spar, aligned over their appropriate locations on the plans. Push rib **W-2** **forward** against the spar. **Make sure each rib is vertical and the jig tabs are contacting the building board**, then glue **W-2** through **W-11** to the spar.



- ☐ 4. Test fit the die-cut 1/8" balsa **Aft Inner Spar** in the notches of ribs **W-2** through **W-7**. The aft edge of the inner spar will be slightly higher than the ribs to allow for trimming later. Sight down the trailing edges of the ribs to make sure they are aligned. Use paper shims under the jig tabs to raise any ribs that are low. Glue the aft inner spar to the ribs **making sure all the jig tabs are contacting the work surface**.



- ☐ 5. Trim the end of the aft inner spar flush with **W-7**. Bevel the notches in ribs **W-7** through **W-11**

and the notches in the die-cut 1/8" balsa **Aft Outer Spar** to account for the forward sweep of the spar. Test fit but **do not glue** the aft outer spar in ribs **W-7** through **W-11**. Fit but **do not glue** the die-cut 3/32" balsa **Aileron Root Rib W-7B**. Make sure the ribs remain aligned over the plans when the aft outer spar is in position.

- ☐ 6. Sight down the trailing edge of the ribs and make sure they are aligned. Use paper shims to raise any low ribs if required. Slip three layers of waxed paper between **W-7B** and **W-7** up to the front edge of the aft outer spar then glue **W-7B** to **W-7**. Glue the aft outer spar to the ribs **making sure all the jig tabs are contacting the work surface**.

- ☐ 7. Fit but **do not glue** the die-cut 1/8" plywood **Dowel Plate (AFT)** into rib **W-2** then add rib **W-1** to the assembly. Still without using any glue, press the **Bottom Main Spar** into the notches and check for a flush fit at each rib. Confirm that the spar extends past the dowel plate and rib **W-11**. Glue the bottom spar to all ribs **except W-1**.

- ☐ 8. Draw a line connecting the two punch marks on the die-cut 1/8" plywood **Dihedral Gauge**.

- ☐ 9. Use the **dihedral gauge** and the **dowel plate** to set the **angle and position** of **W-1** (see the photo at step 10). The line on the dihedral gauge must line up with the **offset reference line** on the plans. *The location of the rib drawn on the plans indicates the **centerline** of the rib – not where the **top** of the rib contacts the plans. Because of this, the top of the will be slightly offset to the right (or left for the other wing panel).*



□ □ 10. Hold the dihedral gauge near the middle of W-1 and lightly tack glue the rib to the top and bottom main spars. **Do not glue the dowel plate until told to do so.**



□ □ 11. Move the dihedral gauge near the trailing edge of the rib, then using the same technique, set the angle and position of W-1. Glue the rib to the aft outer spar.



□ □ 12. Use a spacer (such as one of the dihedral braces or a flap hatch cover) to position the dowel plate 1/16" in front of the main spars. Glue the dowel plate to ribs W-1 and W-2.

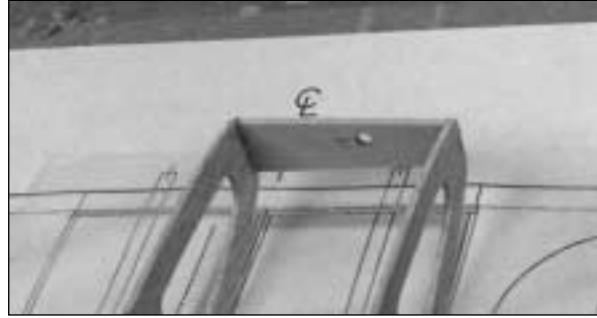

□ □ 13. Glue a die-cut 1/8" plywood **Dowel Plate (FWD)** in the notches of ribs W-1 and W-2.

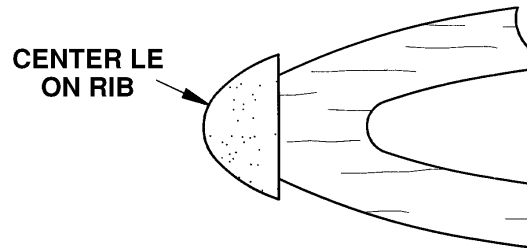

□ □ 14. Cut the shaped balsa **Leading Edge** to the correct length as shown on the plans and carefully bevel the ends. Center the leading edge vertically on the front edge of the ribs, then glue it to ribs W-2 through W-11.



□ □ 15. **Skip this step if you are NOT going to build the optional flaps.** Please consider this strongly – the flaps are not at all difficult to build and they really add to the flight realism and make landings lots of fun. Place the die-cut 3/32" balsa **Flap Root Rib W-2F** next to W-2 as shown on the plans. Slip **three layers** of waxed paper between W-2 and W-2F up to the "V" notch then glue W-2F to W-2 forward of the V notch.



□ □ 16. Trial fit the tapered 18" **Flap Spar** into the "V" notches just behind the aft inner spar and cut it to fit from W-1 to W-7. Make sure it fits all the way down into the notches so the upward facing surface is flush with the ribs. Make adjustments to the notches if necessary then glue the spar into position.



□ □ 17. Make two **Flap Servo Hatch Supports** and two **Aileron** (or releasable drop tank) **Servo Rails** from two of the 1/4" x 3/8" spar cut-offs, then glue them to the notches in the ribs. If you don't plan on using flaps, fill the notches with scrap balsa (or you could install the rails anyway).



□ □ 18. With the bellcrank facing away from the plans, glue the aileron bellcrank plate into the slots in ribs W-7 and W-8.

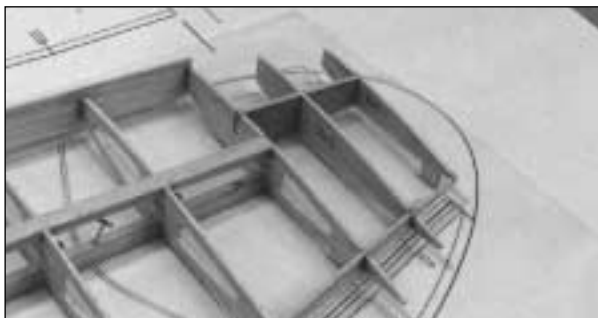

□ □ 19. Test fit **Tip Ribs W-12** and **W-13** and the die-cut 1/8" plywood **Tip Spar** to the tip of the wing. Make sure W-13 is vertical and the jig tabs are contacting the work surface, then glue the assembly in position.



□ □ 20. Locate the 5/8" x 1" x 7" balsa stick and make the **Tip Leading Edge**. Bevel each end as shown on the plans. Glue the tip leading edge in position.

**Proceed to step 25 if you will be installing retractable landing gear.**

□ □ 21. Test fit a 1/2" x 3/4" x 6-3/4" grooved **Landing Gear Rail** into the notches in ribs W-4, W-5, and W-6. The fit should be snug and the groove should be facing away from the work surface. Be sure that the rail extends past W-4 approximately 3/4" as shown on the plans. Use 30-minute epoxy to glue the rail in position.



□ □ 22. Use 30-minute epoxy to glue the 1/2" x 3/4" x 1" maple **Landing Gear Block** to the top of the rail and the side of W-4F.

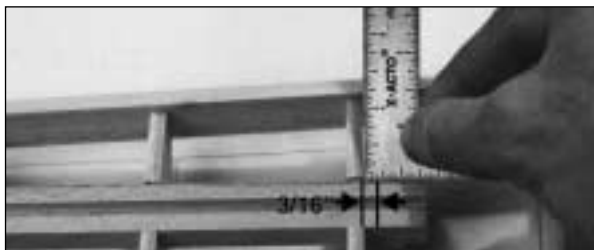

□ □ 23. Draw a line 3/16" from W-4F on the landing gear rail.



□ □ 24. Carefully drill a 3/16" hole at this mark **in the middle of the groove** all the way through the maple block **with the drill perpendicular to the rail** as shown in the photo.



**FOR RETRACT GEAR ONLY**

**Hot Tip:** The key to a durable landing gear mounting structure is building accuracy and good glue joints, **not** lots of epoxy. Please take your time, plan ahead, and work carefully during these steps.

□ □ 25. Before using any glue or drilling any holes, test fit the plywood retract rails in the notches of ribs W-5 and W-6 together with your retracts.

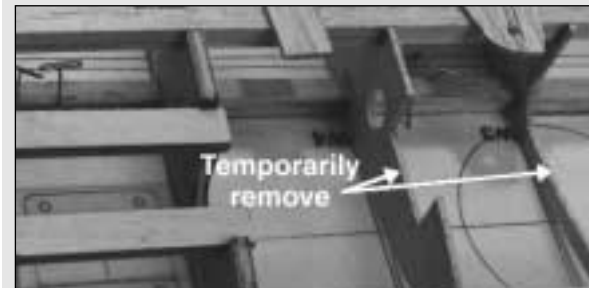

□ □ 26. Remove a section from ribs W-4 and W-5 so you may retract the landing gear, preferably with the wheel installed, into the wing. *The shape or size of the pieces of wood you remove does not matter as long as it provides enough room to allow the wheel and landing gear to fully retract.* These scraps will be glued back in place after this operation.

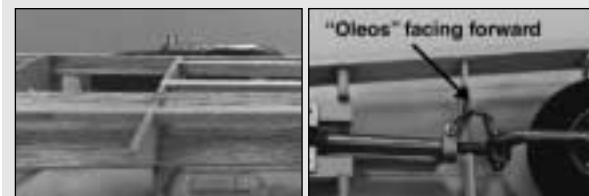

□ □ 27. With the landing gear fully retracted, confirm that the strut and wheel go into the wing an acceptable amount. **NOTE:** With the standard Robart wire strut installation, the landing gear and

wheels will retract fully into the wheel well. With the CJM retracts and the modifications to the rib doublers shown in the sketches, the strut protrudes outside the wing skin about 1/16" to 1/8". It may be possible to fully enclose the wheel and strut inside the wheel well by deepening the notches in the plywood rib doublers W-5R but this is not recommended as it will weaken the structure.

- ☐ ☐ 28. Make adjustments to the notches in the doublers if required, then use 30-minute epoxy to glue the retract rails in position.

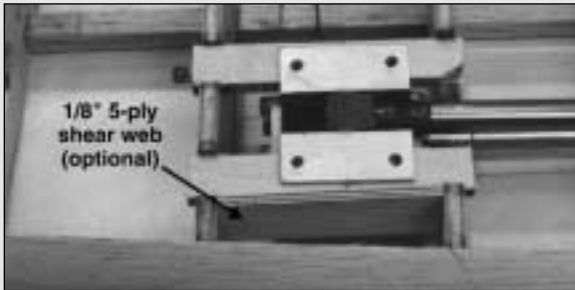

- ☐ ☐ 29. (Optional) Make a **Front Retract Rail Sheer Web** from a 2-1/2" wide piece of 5-ply aircraft plywood (not supplied). Glue it to the front retract rail and the rib doublers with 30-minute epoxy. **NOTE:** This front retract rail sheer web is recommended for solid strut type retracts or flyers who fly off of rough grass fields but is **optional** and not required for coil type wire struts.

*Retract installation will be completed after the wing panels are joined. This will allow you to insure that both installations are identical by comparing the two and making small adjustments if required.*

- ☐ ☐ 30. Use a sanding block and 150-grit sandpaper to blend the upward facing surfaces of the wing ribs and spars.

- ☐ ☐ 31. Use the patterns provided on the plans to make the **Upper and Lower Flap Skins** and the **Aileron Skins** from four 1/16" x 3" x 36" balsa sheets. Use the bevel gauge (assembled during

elevator construction) to mark the bevel line and the rib end line on the inside surfaces of the skins, then sand the bevel just as you did for the elevator and rudder skins. **Note: Be sure you make a right and left set.**



- ☐ ☐ 32. Draw a line on the inside surface of the upper flap skin 3/32" from the outboard tip. This will indicate exactly where to position the skin over W-7 so you do not glue it to W-7B. Glue the upper flap skin to the ribs. **Hint:** Refrain from using accelerator during this step so that the CA you use to glue on the *bottom* flap skin will not prematurely cure.

- ☐ ☐ 33. If building flaps, push a pin between W-2B and W-2 through the **Upper Flap Skin** about 1/8" from the end of the ribs. This "point" will be used later as a reference of where to cut the flap root away from the wing.

- ☐ ☐ 34. Glue the lower flap skin to the wing and the trailing edge of the upper flap skin with thick CA.

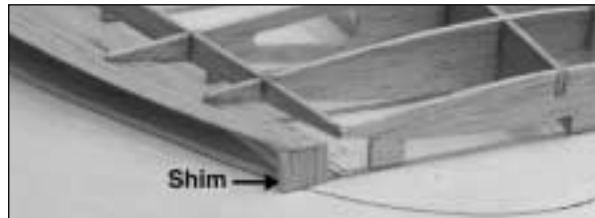

- ☐ ☐ 35. Wet the outside surface of the top aileron skin. Position it on the wing and glue it only to ribs W-7B - W-10. Cut a piece of scrap balsa so that when inserted in between the skin and the building board it raises the skin in alignment with the tip of the aft outer spar. Insert the shim, then glue the

aileron skin to the rest of the ribs. **Leave the shim in place until the wing is removed from the building board.**



- ☐ ☐ 36. Wet the outside surface of the other aileron skin and glue it to the upper skin and ribs.



- ☐ ☐ 37. Custom fit, then glue eight 1/16" balsa **Vertical Grain Shear Webs** to the rear of the main spars between all ribs **except** W-1 and W-2, and W-2 and W-3. **NOTE:** It's still important to keep the wing on your flat building board. When you remove two crossed pins to glue in a shear web, replace one pin by pushing it through the shear web and spar into the building board.

- ☐ ☐ 38. Remove the wing from the building board. Carefully trim off all jig tabs **except the jig tabs on W-1 and W-11**. Sand the ends of the spars and the flap sheeting flush with W-1.

**Return to step 1 to build the other wing panel. Use the other half of the wing plan and remember to build a right and a left wing panel.**

## JOIN THE WING PANELS



❑ 1. Cut away the portion of rib W-1 behind the dowel plate and 1/16" behind the main spars. Cut away the portion of rib W-2 behind the main spars on the line you drew earlier. This will allow the dihedral braces to pass through the ribs. Do this to both wing panels.



❑ 2. Test fit both die-cut 1/16" plywood **Dihedral Braces** into each wing half. Make sure the brace centerline can go all the way to the wing centerline. Trim the ends of the brace slightly if required.



❑ 3. Align the holes of the die-cut 1/8" plywood **Wing Bolt Plates (TOP) and (BOTTOM)** then glue them together.

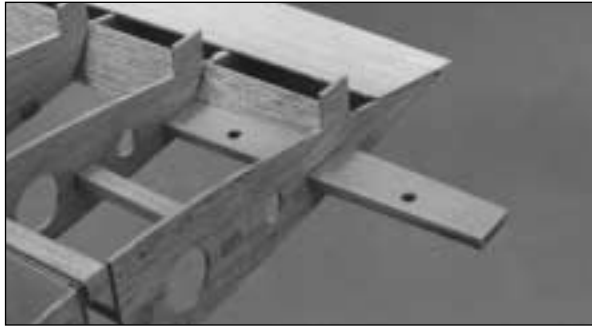

❑ 4. Test fit the wing bolt plate into each wing panel. Make adjustments if necessary.

**IMPORTANT: Check your work surface with a metal straightedge to make sure that it's perfectly flat before proceeding. Make a "dry run" of step 5 before actually performing it with glue. Predetermine where you will place clamps on the dihedral braces and W-1's.**

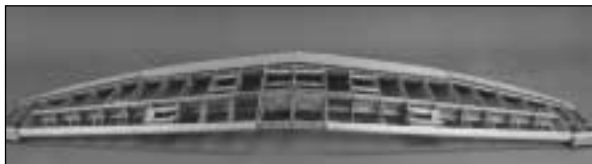

❑ 5. Join the wing halves with the dihedral braces and the wing bolt plate. Place the wing upside down on your **flat** work table. Slide the 1/2" x 2" x 6-1/2" balsa **Wing Dihedral Block** under W-1's and the 1/4" x 1/4" x 7-7/8" balsa **Wing Jig Sticks** under the W-11's at each wing tip. The dihedral block and wing jig sticks should be positioned so they contact the jig tabs and the top main spar. The 1/2" side of the block should be contacting the work surface and the wing, and the 2" side of the block should be vertical.



❑ 6. When you have confirmed that all parts fit well, disassemble the pieces. Coat the dihedral braces where they will contact the spars, the spars (where they will contact the dihedral braces of course) and W-1's with **30-minute epoxy**. Reassemble the wing parts and place the wing on the dihedral block and wing jig sticks as you did in the previous step. Make sure the wing is properly jugged and all parts are in position. Clamp the dihedral braces to the spars. Clamp the W-1's together. Use a cloth to remove excess epoxy before it cures.

❑ 7. After the epoxy has cured, remove the clamps. **Do not remove the jig tabs from W-11 and W-1 yet.** Glue the die-cut 1/8" plywood rib doublers **W-1D** and **W-2D** to ribs W-1 and W-2 as shown on the plans. Apply a fillet of epoxy around the wing bolt plate and where both W-1's meet the aft plywood dihedral brace.

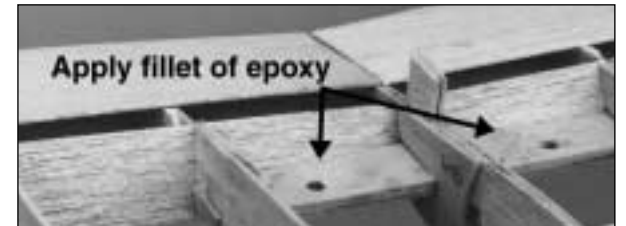

❑ 8. Glue the last two 1/16" shear webs between W-2 and W-3 on both sides of the wing.

## PREPARATIONS BEFORE ADDING BOTTOM WING SHEETING

❑ 1. Sand the 3/16" x 36" **Outer Pushrod Tube** so glue will stick to it. Cut it to the lengths shown on the plans for the right and left wing panel. Slide the pushrod tubes through the holes in the ribs and glue the tubes in position.

**If not installing retracts, skip the next three steps.**

❑ 2. Test fit both retracts in the wing and confirm that the struts are at the same angle when retracted and extended. Make adjustments if necessary, then drill the retract mounting holes for the mounting screws recommended by the manufacturer.

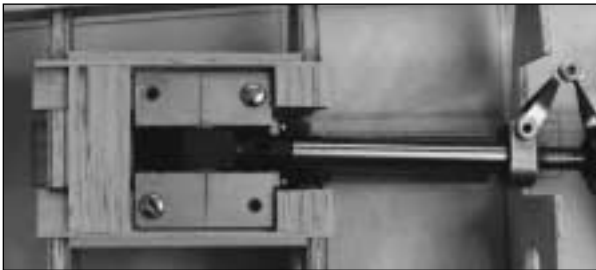

❑ 3. Temporarily mount the retracts to the rails, then use left over balsa to build a supporting base for the sheeting, as shown in the photo.

❑ 4. After you have completed the retract installation in both wing panels, remove the landing gear. Replace and glue in the scraps of wood you removed from W-3 and W-4.

### SHEET THE BOTTOM OF THE WING

Our suggested wing sheeting process allows you to sheet the wing panels with two skins per side with the only seam conveniently placed directly over the main spar. This technique is *better* than sheeting the wing with individual sheets, *easier* than sheeting the wing with one big sheet and allows you to **presand** all of the seams that will be over open structure.

*All balsa sheeting will usually bend when it's cut from the log since stresses are relieved. For the best results, trim the edges of the wing sheeting with a long metal straightedge and a **sharp** knife before joining them.*

❑ 1. Sort through the remaining 1/16" x 3" x 30" balsa and pick out the best eight sheets to be used for the top surfaces of the wing panels. Pick out eight more 1/16" x 3" x 30" sheets to use on the bottom of the wing.

❑ 2. Lay waxed paper over a flat, **smooth** work surface.

❑ 3. Make a **wing skin half** by edge gluing two 1/16" sheets together. Refer to the **Hot Tip** below for tips on making skins.



#### HOW TO PREJOIN SHEETS FOR WING SKINS

Following is a recommended method of prejoining the 30" long sheets used to make the wing skin halves with **Aliphatic Resin**. The quantity of aliphatic resin used to glue sheets of wood together is easier to control than CA and sands easier as well. The result is a wing skin with nearly invisible glue joints that requires little presanding. Less presanding allows you to avoid making the 1/16" skins too thin.



❑ A. After sorting the sheets used for the top and bottom, and truing the edges of each sheet, use masking tape spaced about every 4" along the seam of the two sheets to tightly hold them together.

❑ B. Lay a 30" long sheet of waxed paper on the work table.



❑ C. Apply a light bead of aliphatic resin to one of the edges of the taped together sheets then immediately lay it down on the waxed paper.



❑ D. Use a credit card or piece of thin, rigid plastic as a squeegee to simultaneously wipe away the excess glue and press the two sheets down so the edges are even.

❑ E. Use a sanding block and 220-grit sandpaper to presand the sheets before fitting and gluing to the wing.

**NOTE:** The steps below show the sheeting of a wing **with** functioning flaps. Wings without flaps are sheeted the same way.

❑ 4. Fit one of the 1/16" x 6" x 30" balsa skins you just made in place on a wing panel, with one edge butted against the LE. Trim the leading edge at the tip to match the sweep of the wing outboard of W-11. After you are satisfied with that fit, trim the trailing edge so it ends at the **center** of the bottom main spar. Save the large scraps of sheeting. Trim the root of the sheet so it ends at the seam between the W-1's and trim the tip about 1/4" past W-13. Make both **Forward Bottom** wing skins.

❑ 5. Place the wing upside down on your flat building table as it was when you were gluing the two halves together. Use the wing dihedral block and the wing jig sticks.

**NOTE: The bottom of the wing must be sheeted with the jig tabs on the dihedral block and the wing jig sticks in position to avoid twists.**



❑ 6. Apply a bead of thick CA to all of the structure that the front wing skin half will touch. Press the wing skin down onto the frame and hold it until the CA cures. Use masking tape or T-pins if necessary. **Hint:** Even if you use thick CA you still must proceed rapidly while positioning the wing skin. Many modelers prefer aliphatic resin for gluing wing skins in position. This allows much more time to accurately position the wing skin. T-pins should be used to hold the skin to the ribs.

**Hint:** The best balsa filler, is **no** balsa filler! *Take your time fitting all sheeting and skins in place. With a little bit of careful sanding you will be rewarded with perfectly matched joints and a lighter, stronger airframe.*

❑ 7. Glue the other forward bottom wing skin to the wing.

❑ 8. Make the **Aft Bottom** wing skins. The trailing edge of the aft bottom sheet doesn't have to be cut perfectly – it only needs to cover the inner and outer trailing edges so make the skin just a little wider and trim it later. Cut the aileron pushrod exit and glue 1/16" balsa strips to the inside of the sheeting on both sides of the exit. Fit both skins.



❑ 9. Glue the aft bottom wing skins in place. **NOTE:** If you are **not** building flaps, there should be no gap between the flap and the aft bottom wing skin. Use the strip of sheeting removed from the forward skin halves to fill this gap. Remove jig tabs from the W-1 and W-11 ribs.

#### **PREPARE THE WING FOR THE TOP SHEETING**

❑ 1. Use a T-pin to poke a hole through the bottom sheeting in the four corners made by the flap servo hatch rails and the ribs. Use the 1/16" ply flap servo hatches and the pin holes as a guide to remove the bottom wing sheeting for the flap servo hatch.

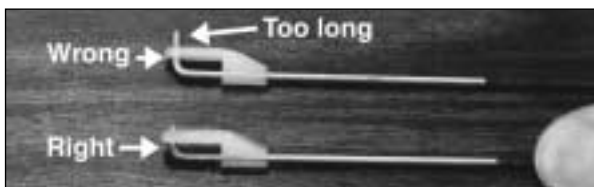

❑ 2. Make the **Outer Aileron Pushrods** from the **4" Threaded End Rod**. Use a **Nylon Clevis**

with a **Clevis Retainer** on the horn end and a **Nylon Faslink** on the bellcrank end. Make the pushrods the length shown on the wing plan top view.

❑ 3. Enlarge the outer hole (that the Faslink will connect to) of both bellcranks with a 5/64" (or #49) drill bit. Install the pushrods with the Faslinks.



❑ 4. Make the left and right **Inner Aileron Pushrods** from one **36" Threaded Both Ends Rod**. Start by cutting a **left** pushrod that is 17-1/2" long and a **right** pushrod that is 15-5/8" long. Cut six 1/4" long pieces from the inner pushrod tube and slide three evenly spaced pieces onto each rod.

❑ 5. Use silver solder to solder a brass **Threaded Coupler** onto the non-threaded end of each rod. Thread the **Dual-end Ball Link** onto the threaded coupler of only the **left** (longer) pushrod and slide it into the pushrod guide in the left wing. Slide the other pushrod into the guide in the right wing.

❑ 6. Screw a **Clevis** with a **Clevis Retainer** onto the "bellcrank end" of each pushrod. Screw the threaded coupler of the right pushrod into the dual-ended ball link (two pliers will be required for this operation).

❑ 7. Temporarily connect the clevises to the bellcranks. Adjust the length of each rod by screwing or unscrewing the clevises as required. The length of the rods is correct when both bellcranks are positioned at 90 degrees to the support (AB). Snap the clevises onto the bellcranks, then position the clevis retainers.



□ □ 8. Install a **Ball Stud** with a **Nut** onto a servo arm. Use epoxy or plastic compatible thread lock to permanently secure the nut to the ball stud. Snap the ball stud into the dual-end ball link then fit the servo arm to the servo. Confirm that both bellcranks are centered as described in the previous step, then mount the servo to the servo rails. Add a few drops of thin CA to the holes in the balsa servo rails, then let it soak in and cure to give the wood screws some more “bite”.

□ □ 9. Cut two pieces from a 3/16" x 3/16" x 24" balsa stick and glue them between both W-2's and W-1's to make a “ledge” for the sheeting.



□ □ 10. Mark the location where the wing bolts will pass through the bottom sheeting. **Hint:** Push a sharpened piece of 1/4" brass tubing through the wing bolt plate and out through the sheeting.

□ □ 11. Mark the approximate location of the flap servo hatches (if installing flaps). Use a pin to poke holes through the sheeting at the corners of the flap servo hatch **inside** the servo hatch rails and ribs W-3 and W-4.

□ □ 12. **If you will be installing fixed landing gear**, use the same technique to locate the position of the LG blocks. Push a pin through the sheeting at each end of the grooved block, then drill a 3/16" hole through the sheeting at the location of the LG block. Trim the sheeting from the groove in the LG block to accommodate the landing gear.



□ □ 13. **If installing retracts**, cut strips from a 1/16" x 3" x 30" balsa sheet to fit between ribs W-2 and W-3, W-3 and W-4, and W-4 and W-5. **Notice the grain direction.** Glue the strips to the inside of the bottom wing skins on both sides of the wing. This will strengthen the wing skins around the wheel well cutouts.



□ □ 14. **If installing flaps**, make six **Flap Hinge Blocks** from the shaped 5/8" x 9" stock. Glue them to the inner trailing edge and the bottom sheeting in the locations shown on the plans. Mark the location of the flap hinge blocks on the outside of the inner trailing edge.



□ □ 15. Make six **Aileron Hinge Blocks** from the 3/8" x 1/2" x 9" balsa stick. Glue them to the outer trailing edge and the bottom sheeting in the locations shown on the plans. Mark the location of the aileron hinge blocks on the outside of the outer trailing edge. Be sure the tip end block is flush or below the TE.

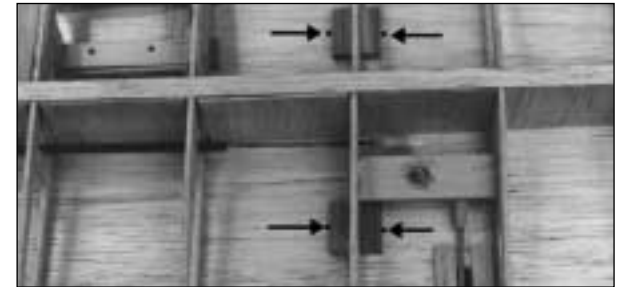

□ □ 16. If installing the **Outboard Drop Tank Pylons**, cut four 1" long blocks from the 1/4" x 3/8" x 9" **Outer Pylon Mounting Rail** glue the blocks to rib W-7 in the bottom sheeting in the locations shown on the plans. Poke a pin through the sheeting on both sides of the blocks then, drill a 5/64" hole through the sheeting between the blocks into the rib.

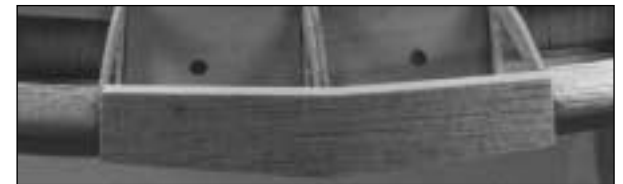

□ □ 17. Trim the ends of the 7/16" x 1-5/8" x 6-5/16" balsa **Wing Center LE** block until it fits on the forward dowel plates between the leading edges. Cut the slight “V” shape to match the dihedral of the wing then place the wing center LE back on the wing.



□ □ 18. Mark the location of the wing dowels from inside the wing. Remove the wing center LE and drill 1/4" holes at the marks. **Hint:** Use a sharpened 1/4" brass tube to mark the location and to "punch" the holes—it really does a clean job. **Do not glue the wing center LE in place yet.**

□ □ 19. Test fit, **but do not glue**, the 1/4" x 5-3/8" wing dowels with the wing center LE. Make adjustments if required then remove the dowels and the wing center LE. **Hint:** Slightly round the front of the dowels to allow them to plug into the fuselage.

**Proceed to step 21 if installing retractible landing gear.**

□ □ 20. Test fit both prebent 3/16" landing gear wires in the landing gear blocks. Temporarily mount the landing gear wires to the wing with the nylon straps and #2 x 3/8" screws as shown on the wing plan. **Hint:** Remove the balsa sheeting from under the straps so they will be inset in the bottom of the wing.

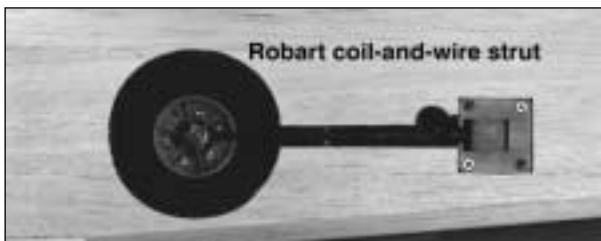

□ □ 21. Make the cutouts in the bottom wing skin for the retracts. It's easiest to first make the cutout for the retract mount and strut without the wheel. Mount the wheel to the strut and make the cutout for the wheel. Allow more clearance behind the wheel than in front of the wheel—the more clearance the less trouble you are likely to have at the flying field with the retracts hanging up in the wheel well (3/32" - 1/4" behind the wheel is realistic).



□ □ 22. Now is a good time to fuelproof inside the wheel wells where you will not be able to reach with a paint brush after the top wing sheeting is in place. **NOTE:** If you elect to coat the inside of the wheel wells later, it must be done **before** the covering is applied. The paint tends to soak through the wing skin which can blemish the covering.

□ □ 23. If you plan to make the outboard drop tanks releasable, install the cables and the mechanism now. The instructions included with the drop tanks include **general information** on how to hook up the release system and cables.

□ □ 24. If you haven't already done so, remove the remaining jig tabs. Use a sanding block on the upper surfaces of the wing to blend all the ribs, spars and trailing edges. Inspect all glue joints and add CA to any joints that don't look strong.

## SHEET THE TOP OF THE WING

The top of the wing will be sheeted in four sections like the bottom of the wing.

□ 1. Temporarily reinstall the 1/4" wing dowels in the wing. Locate the die-cut 1/8" plywood **Leading Edge Jigs, Trailing Edge Jigs (A) and (B), and the Tip Jigs**. Assemble the trailing edge jig (A) and (B).



□ 2. Place the leading edge jigs onto the dowels and set the wing on your **flat** building table with the trailing edge jig in the center of the wing under the trailing edge. **Hint:** Tack glue the jigs in position.

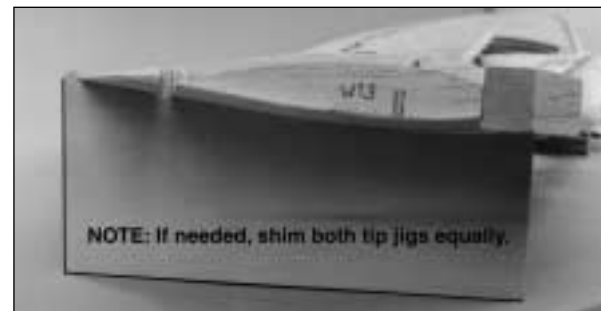

□ 3. Place the die-cut 1/8" plywood tip jigs under each wing tip directly under ribs W-11. The tabs at the aft edge of the tip jigs should contact the trailing edge of the ailerons at W-11. Now the wing is ready for sheeting.

□ 4. Make the **upper forward** skin halves just like you made the bottom forward skin halves. Save the large scraps for the upper aft sheeting.



**Hint:** Before performing step #5, make marks on the leading edge and main spar at each rib then transfer them to the sheeting. **Lightly** draw lines connecting the marks on the sheeting so you know where to insert the pins. First, apply a bead of aliphatic resin to only the ribs, then position the sheet on the wing and glue the leading edge of the sheet to the leading edge of the wing with CA. Pin the sheeting to the ribs and glue the aft edge of the sheeting to the spar with CA.



□ 5. While the wing is sitting on the jigs, glue both forward skins to the wing. Place weights in the middle of the wing to hold it down to the jigs.



□ 6. Join each strip of wood trimmed off the upper forward skins to each of the remaining two 6" x 30" sheets to make the **Upper Aft Skins**. Trim the upper aft skins to fit the wing. If building flaps, there should be a 1/16" gap between the flap and the sheeting. If not building flaps, no gap should exist.

□ 7. Glue the upper aft skins to the wing. Weights placed over the sheeting in addition to T-pins will hold the skins down to the ribs while the glue cures.

□ 8. After the glue has cured, remove the wing from your building board. If you did a good job prejoining the sheeting and kept the sanding to a minimum, you should have a pretty solid wing. Trim the sheeting where it protrudes past the edge of the wing tips.

□ 9. Razor plane and sand the wing leading edge until it blends well with the sheeting to form a smooth airfoil. Refer to the cross sections on the plans. Final sanding of the leading edge near the tips should be done after the tip blocks have been added.

**NOTE: If you are not building the operational flaps, skip the following section and proceed to build the ailerons.**

## BUILD THE FLAPS



□ □ 1. Remember the pin hole you made in the upper flap skin? Insert a pin through this hole, between W-2F and W-2, through the **lower** flap skin.



□ □ 2. Use this point as a reference of where to cut the flap away from the wing. Use a #11 blade to cut through the upper and lower flap skin and a razor saw to cut through the shaped flap spar on the bottom of the flap.



□ □ 3. Turn the wing upside down and separate the flap from the wing by cutting each rib with a razor saw. Do not cut into W-2 and W-7 but only cut through the flap root ribs glued to them (W-2F and W-7B respectively). The cut should be made at the front edge of the top and bottom flap skins. You

will see the punch marks in the ribs that can be used as a guideline as well. Reference the cross sections of the wing plans.

❑ ❑ 4. **Carefully** remove the flap from the wing. If CA has glued the waxed paper layers together, cut the inboard and outboard ends of the flaps free with a razor saw.



❑ ❑ 5. Sand the LE of the Flap Ribs flush (and at the same angle) with the Flap Spar. Use a long T-bar or sanding block to maintain a **straight** LE. **NOTE:** Stop sanding when the T-Bar contacts the flap sheeting. Do not sand the flap sheeting as this will change the height of your flaps and cause the flaps to fit the wing improperly.

❑ ❑ 6. Set the flap over the plans and mark the location of the 1/16" die-cut birch ply **Flap Horn**. **NOTE:** There is a different Flap Horn location for each flap. **Insert but do not glue** the Flap Horn into the flap.



❑ ❑ 7. Cut the 5/8" x 1-3/8" x 14-1/4" balsa **Flap LE** to fit on both sides of the Flap Horn. Cut a 1/16" deep notch in **one** of the Flap LE sections to allow passage of the Flap Horn. Glue the longest Flap LE in position **exactly** as shown on the plan, with the top of the Flap flush with the top of the Flap LE.

❑ ❑ 8. Remove the plywood flap horn and **tack glue** the other, shorter flap LE in position.

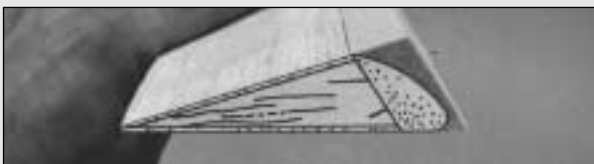

❑ ❑ 9. Cut out the cross sections of the flap **root** and **tip** from the wing plans and tack glue them to each end of the flap (3M 75 Repositionable Spray Adhesive recommended). Shape the flap LE to match the cross section on the plans (now on the ends of your flap). A razor plane and a long sanding bar with coarse sandpaper help the job go quickly and accurately. Save the cutouts for the other flap.

❑ ❑ 10. Remove the shorter tack glued flap leading edge. Install and permanently glue in the plywood flap horn, then permanently glue the flap leading edge back in place.



❑ ❑ 11. Trim off the excess ribs from the Inner Aft Spar, then use a 3/4" dowel wrapped with 220 grit sandpaper to sand a radius on the protruding portions of the ribs. Use a #11 blade to carefully shave the remnants of W-2F and W-7B from the ribs. Cut a 1/4" x 1/2" slot in the aft Inner spar to allow the Flap Horn and Clevis to pass (be careful if you're using a Dremel tool—don't cut into the top wing sheeting).

❑ ❑ 12. Reinforce the underside of the wing sheeting (where it overhangs the aft inner spar at the Flaps) by gluing leftover 1/16" x 1/4" balsa strips between the ribs on the underside of the top sheeting.

❑ 13. Repeat steps 1 - 12 for the other Flap.

## ***FIT THE FLAPS***

❑ 1. Test fit the flaps to the wing. "Fine tune" the ribs, ends of the flaps and top wing sheeting in the flap section until you get a good fit between the flap and the wing. Sand a bevel along the trailing edge of the wing sheeting in the flap section to allow the flap to clear when it's in the *up* position.

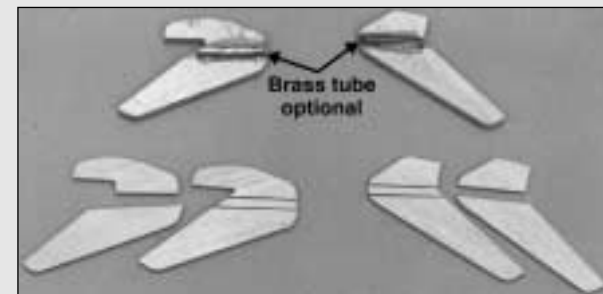

❑ 2. Assemble the two **Flap Drill Guides (A & B)** by gluing the six die-cut 1/8" ply pieces as shown. **Hint:** Glue a piece of 7/32" brass tubing to the drill guides for even more accurate drilling of the holes.



❑ 3. Position the **wing** flap drill guide on the wing at each hinge block (you marked earlier) and drill the holes for the hinge points in the wing. **Hint:** Instead of a drill bit, use a piece of 3/16" tubing sharpened at one end to make the holes.

❑ 4. Insert three **#309 Robart Super Hinge Points** into the wing but **do not glue them in until after the wing and the flaps are covered**. Fit the flap to the wing and mark the locations of the hinge points on the flap.

❑ 5. Use the **Flap Drill Guide** to drill the holes in the flap just as you did in the wing.

❑ 6. Cut 1/4" off the end that fits into the flap of the outermost hinge point. Test fit the flaps to the wing with the hinges. Adjust the position (depth) of each hinge in the flap and the wing until the flap sets back in its original position before it was first cut from the wing. Check the fit and run the flaps through their complete range of motion. Make any required adjustments until the flaps swing freely. Remember, the flaps must **close flush** against the wing TE.

## BUILD THE AILERONS



❑ 1. Use a razor saw to cut the ribs and remove the ailerons from the wing. Use a sanding block to true the trailing edge of the wing and the leading edge of the aileron.

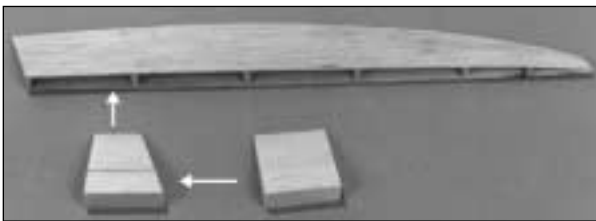

❑ 2. Bevel one side of the shaped balsa **Aileron Horn Shim** so it will match the angle of the rib inside the aileron at the location shown on the

plans. When the base fits, apply glue **only to the side and the top** of the base and then permanently glue it in position.

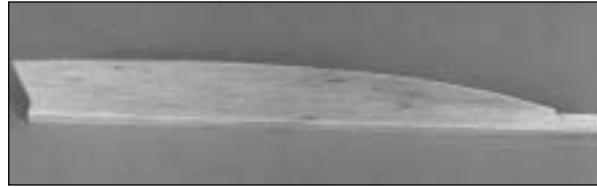

❑ 3. Center and glue a 5/16" x 5/8" x 15" **Aileron Leading Edge Cap** to the aileron. Use a razor plane, then a sanding block to blend the leading edge to the shape of the aileron. Trim the ends so they are flush.

❑ 4. Use the marks made earlier on the outer trailing edge of the wing (or the plans) to mark the locations of the hinges on the aileron.



❑ 5. Draw a centerline on the leading edge of the aileron. Cut the hinge slots in the aileron and the wing.



❑ 6. With the centerline of the aileron as a guide, use a razor plane and a sanding bar to make a bevel for the aileron deflection. Reference the cross section on the plans.



❑ 7. Mark the location of the 1/8" x 3/4" x 3/4" plywood **Aileron Horn Block** on the bottom of the aileron. Cut away the sheeting, leading edge and part of the balsa horn block mount until the horn block fits flush with the aileron.



❑ 8. Glue the aileron horn block in position, then use a sanding block to blend it to the shape of the aileron. Test fit the aileron to the wing with the hinges. Connect a **Small Control Horn** to the clevis on the aileron pushrod. Mark the location of the control horn on the horn block in the position indicated on the plans. Drill 1/16" holes for the #2 x 3/8" sheet metal screws that secure the horn. Some modelers temporarily connect the ailerons for radio set-up prior to covering the model or this can be saved until after covering.



❑ 9. Glue the **wing tip blocks** to the wing tip at each W-13. Refer to the plans, then shape the tips with a razor plane and a sanding block.

❑ 10. Temporarily install the wing dowels, then glue the partially shaped wing center leading edge to the wing.



❑ 11. Remove the dowels and use a razor plane and a sanding block to blend the center leading edge to the rest of the wing. After the shaping is done, glue the dowels in the wing with 30-minute epoxy. Be certain that the dowels are “keyed” into the aft dowel plate – look in the wheel wells through ribs W-2.

❑ 12. Complete the sheeting of the wing by filling any spaces that have not been sheeted with left over 1/16" balsa – areas such as the aft center section of the wing where the flaps have not been cut away from the wing and the corner of the wing where the flap and ailerons meet.



❑ 13. Cut the hole in the top wing sheeting for the 1/4" x 2" nylon wing bolts. **Hint:** Push a 1/4" brass tube sharpened at one end through the hole in the bottom sheeting (made earlier) and through the wing bolt plate into the top sheeting. *Use a backup block so you don't punch a hole through your hand!*



❑ 14. Insert the wing bolt into the holes you made. The heads of the bolts will stop at the sheeting because you have not enlarged the holes yet.

❑ 15. Place the cardboard wing tube over the heads of the bolts and trace around them with a pen. Remove the tube and the bolts then make the holes for the wing bolt tubes. Slightly enlarge the 1/4" holes in the top of the wing sheeting to allow the wing bolts to pass easily.

*Oh boy! We can get a good idea of how big this thing is going to be and how cool it's going to look by mounting the wing to the fuse and setting it on its landing gear for the first time! This will only take a few minutes...*

## MOUNT THE WING TO THE FUSE

❑ 1. Trim the fuselage sheeting until it accurately matches the contour of the balsa wing saddles. Sand only **to** the balsa saddles and do not change the shape of the plywood crutches as this determines the wing incidence.

❑ 2. Set the wing in the fuselage with the dowels in the dowel holes in former F-2. Make slight adjustments to the dowel holes in F-2 if required.

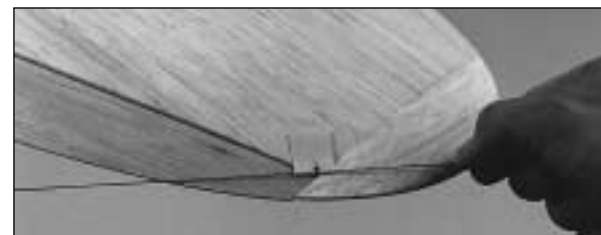

❑ 3. Align the wing with the fuselage by holding a string with one end attached to a pin centered at the tail, up to a wing tip. Put a piece of tape on the string to mark the intersection of the string and the wing tip. Swing the string over to the other wing tip and check to see if the distances are the same. Adjust the position of the wing until it is properly aligned.

**NOTE: Make sure the wing is held securely and cannot shift while you are drilling the mounting holes.**



❑ 4. With the wing aligned and held in place (tape or tack glued), insert a 1/4" drill and **lightly** mark the center of the wing mount holes on the mount blocks.



❑ 5. Remove the wing and finish drilling the holes with a #10 (13/64") drill bit through the wing mount blocks. Tap the holes with a 1/4-20 tap. Add a couple drops of thin CA to the holes to harden the threads, then re-tap the holes after the CA has fully cured.

### BUILD THE WING FILLET



❑ 1. With the wing bolted to the fuselage. Mark a reference line on both sides where the wing trailing edge and leading edge contacts the fuselage. Remove the wing from the fuselage.



❑ 2. Place a straight edge on the fuselage at the indication marks you made in the previous step and draw a line from the rear indication line about 3" aft.

❑ 3. Trial fit a 1/32" plywood **Wing Fillet Base** on the wing saddle of the fuselage. Make adjustments if required. Use a hobby knife with a #11 blade to **lightly** scribe a line on the fillet base from the corner where it meets the rear of the fuselage out to the edge—cut only through the bottom layer of the three-ply plywood.



❑ 4. Tape the fillet base to the plywood saddles in a few spots.

❑ 5. Perform the previous three steps for the other fillet base.

❑ 6. Tape a layer of waxed paper or plastic food wrap to the top surface of the wing in the wing saddle area. Bolt the wing firmly onto the fuselage. Check to make sure there is no interference with the wing saddle and make adjustments if required.



❑ 7. With the wing bolted to the fuselage, carefully "bend-up" the portion of the wing fillet at the scribe line and align it on the fuselage with the line you drew earlier. When the wing fillet is in position, glue the wing fillet to the fuselage with medium CA.



❑ 8. Use a sharp knife or a Moto-Tool with a sanding drum to adjust the "curve" of both the fillet bases so it meets the trailing edge of the flap.

**NOTE: The wing fillet may be built up with small balsa blocks or you may use the technique described below.**



❑ 9. Cut the 24" x 1/4" balsa triangle stick half. Mark both halves every 1/2" for the first 4" then two more marks 1" after that. Use a razor saw to cut about 3/4 the way through the triangle stock at the marks.



❑ 10. Glue the triangle stick to the fillet base and the fuselage with medium CA.



❑ 11. (Optional) Use the template on the plans to make two sets of wing fillet braces from left over 1/8" lite ply. Glue the braces to the fillet and the fuselage sides. This will make the fillet more durable in case of rough handling during transport.

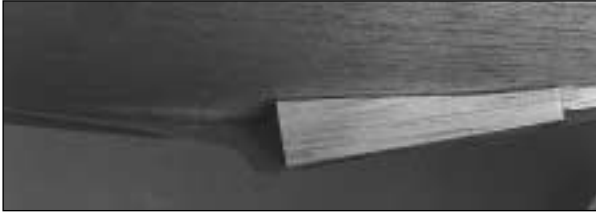

❑ 12. To make finishing of the fillet easier, remove the wing from the fuselage. Cut a tapered piece of 1/16" sheet balsa as shown in the photos. Test fit it against the wing saddle and refine the fit. A little concave curvature on the side that contacts the plywood wing fillet helps.



❑ 13. Make another of sheet balsa to fit behind the first piece in the "corner" of the fillet. These pieces don't have to fit very accurately; we are just trying to fill some of the space and save a little on the amount of filler.



❑ 14. Now the fun part! Get out the balsa filler (Hobbico HobbyLite recommended) and begin building up a smooth fillet. This should be done in at least three layers letting the previous layer fully dry before applying the next. **Hint:** Wet your fingers when forming the final layers and you will really be able to "feather in" the fillet to the fuselage. This will require minimal sanding in the end.

### **BUILD THE WING BELLY PAN**

❑ 1. Bolt the wing to the fuselage and set the model upside down on your building stand. Reference the plans for the locations of the die-cut 1/8" plywood **Belly Formers 3-C** and **4-C** then mark their position on the bottom of the wing.

❑ 2. Test fit **5-E** and make sure that when in position at the trailing edge of the wing, it is the same height as 5-D. Make adjustments to 5-E if required then glue it to the **wing only**. Cut a 3/16" square stringer to fit between 5-E and F-1. Glue the stringer to 5-E and F-1 only.



❑ 3. Position **2-C**, 3-C and 4-C, under the stringer at their proper locations. You may have to bevel the lower aft edge of 2-C so it will fit between the wing and F-2. Glue 3-C and 4-C **but not 2-C** to the wing.

❑ 4. Place two more 3/16" stringers in the notches from 5-E to F-1 then glue the stringers to all the formers **except 2-C**.

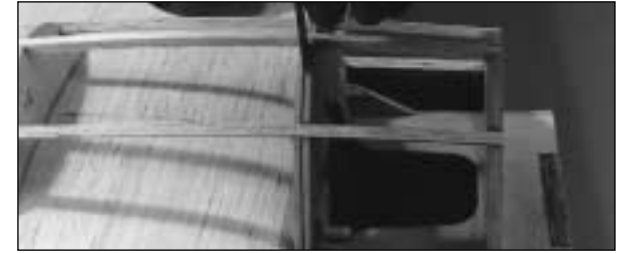

❑ 5. Adjust the position of 2-C so you can place a shim such as a metal ruler or a piece of 1/32" plywood between 2-C and F-2. Glue 2-C to the stringers and the wing.

Skip to step 1 "Sheet the Belly Pan" if you are not going to install the releasable drop tank.



❑ 6. Glue a 3/16" square stringer to the side of the middle stringer between 2-C and 3-C (just like you did for the tail wheel installation). Cut a notch in the middle stringer to allow actuation of the Great Planes release mechanism (remove the aft post from the release mechanism). Glue another 3/16" stringer to the other side of the middle stringer.



❑ 7. Make a **Mounting Post** from left over 1/8" lite-ply to secure the outer pushrod tube for the release mechanism. Position it so that when the cable guide tube is inserted through the bottom sheeting next to the W-1 ribs, it lines up with the release mechanism. Glue the post to the stringer and the bottom wing sheeting.



❑ 8. Glue two more shorter 3/16" stringers next to the middle stringer behind 3-C to support the sheeting around the release mechanism. Mount the release mechanism to the middle stringer with the screws supplied then trace its outline on the stringers. Remove the release mechanism.

### ***SHEET THE BELLY PAN***

❑ 1. Trace the bottom of the wing (on the fuse plan) to make a pattern for the belly pan sheeting. Make two **belly pan sides** from 3/32" x 3" x 24" balsa sheet. The belly pan sides extend from the bottom wing sheeting to the **middle** of the first stringer. Test fit each sheet, make adjustments as required, then glue them to the stringer, bottom wing sheeting and the formers.

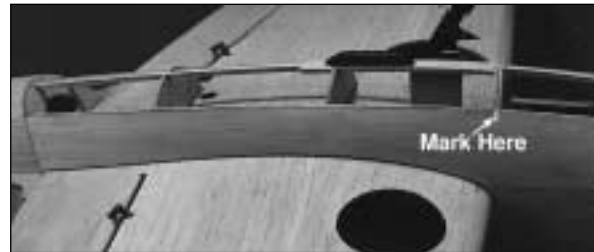

❑ 2. Use a pen to mark on the belly pan sides the location of the **gap** between fuselage former F-2 and the forward belly pan former 2C (so you know where to guide the razor saw when the belly pan is separated from the fuselage).



❑ 3. Estimate the location and cut the oval shaped holes for the wing bolt tubes in each belly pan side sheet. Start by making a small hole in the sheeting above the wing bolts and adjust the position of the hole as you enlarge it. **Hint:** If you have accurately positioned belly pan former 4-C, the **center** of the hole will be 1/4" (17/64" to be exact) ahead of it; and the inner edge of the hole should cut about half-way through the side stringer.



❑ 4. Test fit the tube in each hole and confirm that it will fit over the head of the wing bolts. Make adjustments then cut two 2" sections from the tube.

Insert the tubes in the wing, trace a line on them using the sheeting as a guide then cut the tubes to the approximate beveled shape. Glue the tubes to the belly pan side sheet and the wing sheeting. **Be careful not to get any glue on the heads of the nylon wing bolts and accidentally glue the bolts to the tubes or wing bolt plate.**



❑ 5. Make a **bottom belly pan sheet** from 3/32" x 3" x 24" balsa. After you have custom fit the first section (but before you have glued it in place), use it as a template to make the other half. If you are installing the drop tank release mechanism, use the outline you drew on the center stringers as a guide to cut out a section of balsa to clear it. Glue the sheet in position.

❑ 6. As you did in step 2, use a pen to mark the location of the gap between F-2 and 2C on the bottom sheet.

❑ 7. Make another bottom belly pan sheet for the other side and glue it in position.



❑ 8. After the belly pan is completed, use a razor plane and sandpaper to rough shape the belly pan. With the marks made on the belly pan sheeting as a guide, saw through the belly pan sheeting with a razor saw and separate the wing from the fuselage.

❑ 9. Use balsa filler to build up a small fillet between the belly pan and the wing and fill any other gaps between the sections of belly pan sheeting. Trim the forward bottom fuselage sheeting flush with former F-1.

## BUILD AND FIT THE COWL



❑ 1. Use scissors (Kyosho curved scissors recommended) or a new #11 blade and a hobby knife to cut around the cut lines inside all three parts of the ABS cowl.



❑ 2. Use a sanding block to clean up the edges and to make any adjustments required for a flush fit. Roughen the inside edges of all the joints with coarse sandpaper, then fit the three parts together and secure them with tape. **Hint:** If you will not be installing the optional (but highly recommended) Top Flite replica radial engine, trace the outline of the aft edge of the front part of the cowl onto a sheet of 1/8" lite ply. After trimming and fitting, this will be the baffle to direct the air flow directly over the head of the engine for optimal cooling (the outline of this baffle is included with the replica radial engine kit).

❑ 3. Carefully wick thin CA around the joints and allow the parts to cure. **Do not use CA accelerator.**

❑ 4. Use coarse sandpaper to roughen a 1" wide strip along the top and bottom joints inside the cowl. Use 30-minute epoxy to glue a 1" wide strip of fiberglass tape along the top and bottom joints. **Hint:** When the epoxy is nearly cured and still in a "gummy" state, dip your finger in alcohol and "rub down" the epoxy soaked glass tape to be sure it conforms to all the curves and bumps on the glue joints.

❑ 5. Roughen the glue joints on the outside of the cowl with sandpaper. Fill the seams with Bondo type automotive body filler.



❑ 6. Refer to the detailed drawings on the plans and use a pen to mark the **base** of the twelve die-cut 1/8" plywood **Cowl Mount Block Supports**. Glue a hard wood **Cowl Mount Block** to two bases to make a **Cowl Mount**. Make six of these. **Hint:** Glue six blocks to the side of six supports. After the glue cures, glue the remaining six supports to the other side of the six blocks.



❑ 7. Use the template on the plans to cut the **Cowl Ring** sections from the 1/2" x 1-3/8" x 24" balsa sheet. **Hint:** Use 3M 75 repositionable spray adhesive to temporarily glue the templates directly onto the 1/2" thick balsa sheet. Cut the sections out then peel off the paper templates.

❑ 8. Test fit the six cowl ring sections with the cowl mounts on the front of the fuselage. Reference the detailed sketch on the plans and note the location of the cowl mount supports. **Hint:** With the elevator and rudder removed from the model, you can stand the fuselage up on its tail (carefully please) to easily position the cowl mounts and cowl ring sections. Make adjustments to the cowl ring sections of necessary.



❑ 9. Mark the location of each cowl mount support, remove the cowl ring sections, then permanently glue the cowl mount supports to the firewall. **Hint:** If you're careful you can glue the cowl mount supports to the firewall while the 1/2" balsa cowl rings are in position.



❑ 10. Remove the cowl rings and set the cowl on the fuselage. Reference the plans for the exact position. **Hint:** You could mount the engine to the fuselage and use it as another reference for positioning the cowl. Use a felt tip pen to mark the location of the mounting screws on the cowl. Remove the cowl and drill 1/16" holes through each mark you made.

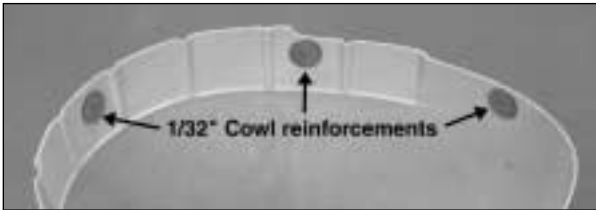

❑ 11. Glue each of the six die-cut 1/32" plywood **Cowl Reinforcements** to the cowl with the punch mark centered in the 1/16" holes. Drill through the holes in the cowl and the reinforcements with a 1/8" drill bit.

❑ 12. Reposition the cowl on the fuselage and confirm that it is in the proper location on the cowl mount blocks. Slight sanding of the cowl mounts may be required to account for the 1/32" plywood reinforcements added in the previous step. On the cowl mount blocks mark the location of the holes for the # 4 x 1/2" sheet metal screws.

❑ 13. Remove the cowl and drill a 3/32" hole through each cowl mount block where you made the mark. Put several drops of thin CA into the holes then re-drill them. Check the fit and temporarily mount the cowl on the fuselage with the screws and #4 washers.

*Now it looks like a P-47!*



❑ 14. Tack glue the cowl ring to the firewall, then sand the sides until they are flush with the fuselage.

❑ 15. Remove the cowl ring sections, then round the corners as shown on the fuselage plan. After they have been shaped, **permanently glue the cowl ring sections** to the firewall.

❑ 16. Cut six 1/2" wide blocks from the left over sheet used for the cowl ring sections. Round the blocks as you did the cowl ring sections and insert them between the cowl block supports to fill the gap.

## FINISH PREPARATION

### FINAL SANDING

Nearly every imperfection in your wood structure will show through the covering material therefore, before covering, you should make a final check of the entire structure. Fix any "dings," then sand the entire structure smooth using progressively finer grades of sandpaper. Many small indentations can be removed by wetting the spot and using a sealing iron to "steam" the ding out.

### FUELPROOFING

Fuelproofing may be performed before or after covering.

❑ 1. Fuelproof the firewall and fuel tank compartment. Grey (mix black and white) K&B epoxy paint or 30-minute epoxy is a highly recommended fuelproofers.

❑ 2. Fuelproof any external exposed wood such as wheel wells and pushrod exits. Use epoxy resin to glue strips of 3/4 oz. glass cloth to the inside of the

top wing skins in the wheel wells. This will fuelproof and reinforce the exposed wood inside the wheel well. **This must be done before the covering is applied as it may blemish the covering.**

## BALANCE THE AIRPLANE Laterally

**SPECIAL NOTE:** Do not confuse this procedure with "checking the C.G." or "balancing the airplane fore and aft."...That very important step will be covered later in the manual.

Now that you have the basic airframe nearly completed, this is a good time to balance the airplane **laterally** (side-to-side). Here is how to do it:

❑ 1. Temporarily attach the wing and engine (with muffler) to the fuselage.

❑ 2. With the wing level, lift the model by the engine propeller shaft and the fin post (this may require two people). Do this several times.

❑ 3. If one wing always drops when you lift the model, it means that side is heavy. Balance the airplane by gluing weight to the other wing tip.

**NOTE:** An airplane that has been laterally balanced will track better in loops and other maneuvers.

## FINISHING

The P-47 does not require much painting to obtain the trim scheme shown on the box as most of the finish is created with Top Flite MonoKote film. The only painting that is required are the plastic parts, cockpit and canopy frame, and the wheel wells. There are many other schemes used on P-47's but the one shown on the box has proved to be highly visible in the air and represents a scale trim scheme.

## COVERING

The technique we will describe here is the how the model pictured on the box was finished. In general, it involves covering most of the model with MonoKote film, then priming and painting the cowl and surface details.

Make sure the structure is smoothly sanded with 320-grit sandpaper. Remove all dust from the structure so the MonoKote film will stick well.

Cover the aircraft with MonoKote film using the sequence below. Make sure the MonoKote film is thoroughly bonded to the structure and all of the edges are sealed. Use a **Top Flite MonoKote Hot Sock** on your covering iron to avoid scratching the MonoKote film.

**NOTE:** When covering areas that involve fillets and sharp junctions, like the tail section of the P-47, cut narrow strips (3/8" to 5/8") and apply them in the corners **before** covering the major surfaces. The larger pieces of MonoKote film will overlap and capture these smaller pieces. This technique also bypasses the need to cut the MonoKote film in these areas after it has been applied. **DO NOT, under any circumstances, attempt to cut the covering material after it has been applied to the fin and stab, except around the leading and trailing edges and the tip.** Modelers who do this often cut through the covering and part-way into the balsa stab skin. This can weaken the stab to the point where it may fail in flight!

#### APPLY THE DECALS

**NOTE:** The decal sheet does not give you everything you need to completely trim your model, but it does provide all the intricate detailing and difficult items.

- ❑ 1. Study the plans and the photos on the box to decide where to place the decals.
- ❑ 2. Thoroughly clean your airplane before applying decals.
- ❑ 3. Trim the decals as close as practical. Carefully apply the decals to the model.

**NOTE:** Certain decals (such as "No Push," etc.) are provided and may be used at your discretion.



#### COVERING TECHNIQUE

You can practically eliminate wrinkles that sometimes occur when using film covering (caused when the model is left out in the sun or in the back of your car) by following this technique used in the **Top Flite** model shop.

1. Cover your sealing iron with a **Top Flite Hot Sock** and turn the heat about 3/4 of the way to the high setting.

2. Say we are going to cover the Stab – cut a piece of **MonoKote** film about 2" larger all around. Strip off the backing and position the film. Tack the film down **smack dab in the middle of the Stab.**

3. Pull (as in stretch) the film toward the tip, sealing it to the balsa from **the center out to the tip.** Work out any **wrinkles and air pockets** as you proceed with a combination of circular and back and forth motion.

4. Do the same procedure working the **opposite direction** from the center.

5. Pull and seal **diagonally toward the four corners**, always starting from the center. The trick is to shrink out any wrinkles before you seal the film to the surface.

6. Use a heat gun to heat and stretch the film around curved surfaces like the stab and rudder tips, while pulling on the excess material. You may need to pull hard to get out all of the wrinkles, so wear a glove if you need to. Follow-up the heat gun with your sealing iron to secure the bond.

The idea behind this approach (which can be applied to any part of the model) is to **pre-stretch the MonoKote** as it's applied, and remove the air pockets that can expand later which cause the sags and wrinkles.

#### Recommended Covering Sequence:

1. Tail fillet strips
2. Rudder left side
3. Rudder right side
4. Bottom of elevators
5. Top of elevators
6. Stab TE
7. Stab bottom
8. Stab top
9. Fin TE
10. Fin left side
11. Fin right side
12. Wing fillet (on fuselage)\*
13. Fuse bottom
14. Fuse sides
15. Fuse top
16. Fuse color bands (if desired)
17. Ends of ailerons and flaps
18. Bottom of ailerons and flaps
19. Top of ailerons & flaps
20. TE surfaces of wing (at ailerons and flaps)
21. Bottom of fuse under wing
22. Bottom of left wing panel
23. Bottom of right wing panel (overlap covering 1/4")
24. Top of left wing panel (overlap covering 1/4")
25. Top of right wing panel (overlap covering 1/4")

\* When covering concave surfaces, follow the iron with a damp cloth, pressing the covering down.

## APPLY PANEL LINES TO THE MODEL (OPTIONAL)

Panel lines are easy to apply and enhance the model's appearance. The pictures on the box may be used for reference, however high quality 3-view drawings should be used for accurate placement of lines if your model will be entered in competition. See page 5 for useful reference books.

Permanent panel lines may be applied by using thin strips of MonoKote film. The MonoKote film can be carefully cut on a smooth surface using a sharp #11 blade and straightedge or you could use a Top Flite MonoKote **SmartStripe™** (TOPR2420) stripe cutting tool.



The SmartStripe is very simple to use. A length of MonoKote film is wound tightly onto a roller and secured with tape. A #11 blade is mounted in a holder that is pressed into contact with the film while the roller is rotated. Stripes of 1/64" are possible with a little practice. The stripe is positioned on the model, then adhered with a sealing iron.

If you prefer to *draw* panel lines, use a **Staedtler Lumocolor 313 Permanent** fine point pen. These pens are available from engineering or drafting supply stores. We suggest using this pen because it works well on MonoKote film and mistakes can be removed with 70% rubbing alcohol. Your model may be cleaned with most cleaners without affecting the lines too badly.

## PAINTING

We recommend **Top Flite LustreKote** for painting the cowl, intercooler exits, wing pylons and canopy frame. LustreKote is available in aerosol spray cans, provides an exact high gloss color match for MonoKote film, and is fuelproof.

**Surface Preparation:** Spray the plastic parts (**except the canopy**) with a **thin** coat of primer. Add a second coat of primer to areas that need it. Wet sand the primer with 400-grit sandpaper using a block where possible. Most of the primer should be sanded off.

Cut the excess material from around the **Canopy**, then sand off the rough edges with 320-grit sandpaper. Mask the clear areas with vinyl electrician's tape or Frisket film (available at art supply stores).

**Apply the colors:** Spray on several very light applications of LustreKote, allowing each coat to dry before respraying. If desired, LustreKote may be polished with a quality car wax after it has fully dried to maximize the shine.

## HINGING

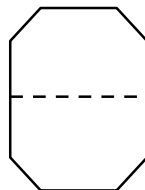
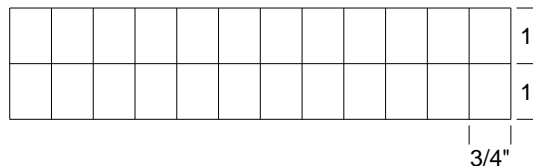

- ❑ 1. Cut 15 hinges (3/4" x 1") from the 2" x 9" CA hinge strip. Trim the corners at a 45 degree angle to make insertion easier.
- ❑ 2. Use a #11 blade in a hobby knife to cut 3/4" wide matching hinge slots in all control surfaces, except the flaps. Work the knife blade back and forth to make sure the hinge slot is "open."

❑ 3. Test fit the elevators to the stabilizer with all of the hinges and the wire joiner in place. Make sure the trailing edge of both elevators are even. Make adjustments to the joiner wire if necessary.

❑ 4. Work a generous amount of 30-minute epoxy into the wire joiner holes in the elevators with a toothpick.

❑ 5. Install the elevator hinges into the stab and, as you do this, insert the wire joiner into their respective holes. Wipe away any excess epoxy with an alcohol moistened paper towel. Glue the hinges in place using 4-6 drops of **thin CA on both sides of each hinge**. There should not be any hinge gap.

## HINGE THE AILERONS AND RUDDER

❑ 6. Install the ailerons and rudder. Glue the hinges in place using 4-6 drops of **thin CA on both sides of each hinge**.

❑ 7. **Flap hinge** installation is covered in the Flap Fitting section on page 39. Permanently install the hinge points using 30-minute epoxy.

## FINAL CONTROL HARDWARE HOOKUP

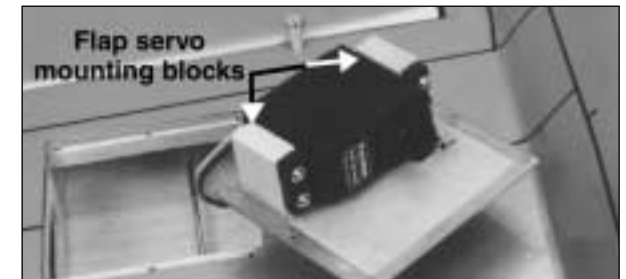

❑ 1. Use 30-minute epoxy to glue the 5/16" x 3/4" x 7/8" hardwood **Flap Servo Mounting Blocks** to the die-cut 1/16" ply **Flap Servo Hatches**. Install the flap servos as shown in the photo and on the plans. *Fish* the servo wires through to the opening at the center of the wing, then connect them to a "Y" cord. Before permanently screwing the servo hatches in position, hookup your radio and set the flap servo throws.

□ 2. Hookup and adjust the flap linkages. Two .074 x 4" **Threaded End Rods** and **Nylon Clevises** are supplied to make the flap pushrods. The flap pushrods are connected to the servos using **Nylon Faslinks**. Refer to the **Control Surface Throws** section for recommended travel.

□ 3. Reinstall the aileron horns with #2 x 3/8 sheet metal screws. Hookup and adjust the aileron linkages.

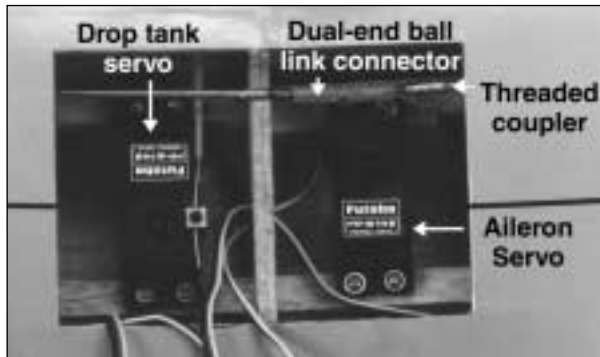

□ 4. Hookup the **aileron** servo the same way you did during wing assembly. Center the servo and adjust the ailerons to line up with the wing tips and flaps.

□ 5. The **Rudder** is hooked up using a **Small Control Horn** and a **Nylon Clevis**. Mark the location of the horn and drill two 1/16" pilot holes about 1/4" deep. Thoroughly soak the holes with CA. Put a drop of CA on the back of the horn and screw the horn onto the rudder with two #2 x 3/8" **Sheet Metal Screws**.

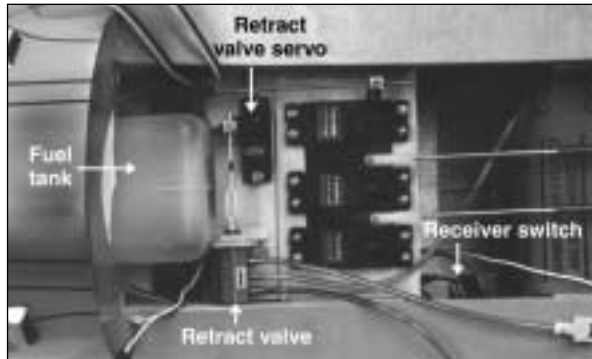

□ 6. The retract **air valve**, **air tank** and **servo** installation can be seen in the photos above and below. *We found that a micro servo worked well for actuating the air valve.* The tank fits in the built-in cradle in formers F-5 and F-6. It can be secured with two #2 x 3/8" screws (not supplied) and a rubber band, or silicone glue.

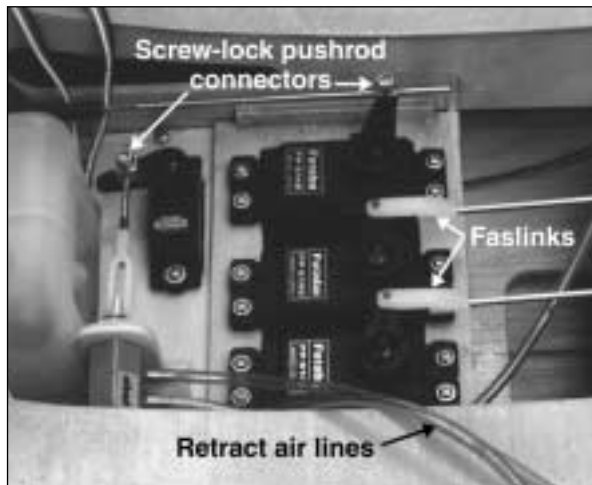

□ 7. Nylon Faslinks are recommended for internal **elevator** and **rudder** hookups. Refer to the photos and plans for proper servo and horn orientation.



□ 8. Due to the variety of engine configurations and each modeler's *preferred* method, no **throttle** hookup materials are included with this kit. We used a 2-56 Threaded Ball Link Connector (#GPMQ3850) at the throttle and a Screw-Lock Pushrod Connector (GPMQ3870) at the servo, joined with a wire-in-tube .074 threaded one end pushrod.

## RETRACTS

□ 1. Hook up the air lines to the retracts and route them to the center of the wing. **Hint:** For more scale retract speed, insert air restrictors in the four lines that connect to the retracts. Position the restrictors at the retract end of the line.

□ 2. Install the retracts, hook them up following the manufacturer's instructions, then test their operation.

## COCKPIT FINISHING

(Basic cockpit)

❑ 1. Sand the inside of the cockpit with 320-grit sandpaper. True up any uneven edges in the cockpit area.

❑ 2. Assemble and paint your pilot.

❑ 3. Paint the interior of the cockpit. An alternative to paint is to cover the inside of the cockpit with a fine-grit black sandpaper for a textured finish. If you use the sandpaper technique, it is still advisable to first paint the cockpit corners black or medium green.

❑ 4. Install the **Instrument Panel Decal**. It be applied directly to the existing panel, or for best results, stick the decal to a scrap piece of 1/64" to 1/16" plywood, trim it to shape, then glue it in place.

❑ 5. Glue the pilot in position. **Hint:** *In addition to gluing, you may also use a screw to fasten the pilot in position from the underside of the cockpit floor.* Add any other cockpit details of your choosing at this time.

❑ 6. Glue the canopy to the model. We recommend using RC-56 glue or 6-minute Epoxy but if you have a favorite technique, use it. You should remove a small strip of MonoKote film (if applicable) from under the canopy frame for good glue adhesion. Use masking tape to hold the canopy in place while the glue cures.

## OPTIONAL COCKPIT INTERIOR

❑ 1. Cut out the existing cockpit floor (if you haven't already done so) and test the unfinished pieces of your Top Flite **Cockpit Interior** (Not included – TOPQ8405) into the opening. Trim the plastic and fuselage interior to obtain a good fit.

❑ 2. Paint and detail the Cockpit Interior following the instructions that are included with the cockpit kit.

❑ 3. Install the cockpit interior with 30-minute epoxy or silicone adhesive. Start with the floor, followed by the back, then the two sides, and finally the instrument panel.

## ADD THE MOLDED SCALE DETAILS

*If you plan on installing the **Intercooler Air Exits** and have made the modifications to the main side stringer, all that remains to be done is remove a section of side sheeting.*

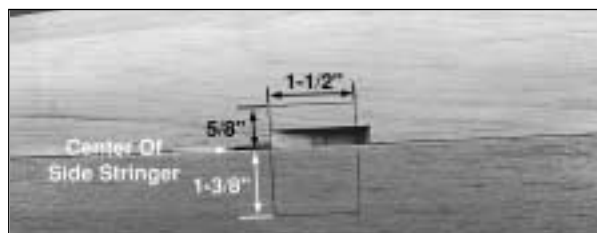

❑ 1. Draw the section of wood to be cut out directly on the fuselage side. The aft edge of the hole is aligned with the aft edge of the cutout in the side stringer. The dimensions are given in the photo.



❑ 2. Use a hobby knife with a #11 blade to cut along the lines. Test fit the intercooler air exit and make adjustments to the hole if required. Glue the intercooler air exits in position with epoxy.

❑ 3. Cut the **Outboard Drop Tank Pylons** along the cut lines.

❑ 4. Use the drawings on the wing plans to make two sets of forward and aft **Pylon Mount Plates** and **Release Mechanism Mounting Plates** from left over 1/8" lite-ply.



❑ 5. Temporarily mount the front and aft pylon mount plates to the wing with #4 x 1/2" button head sheet metal screws (GPMQ3124). Place the pylon on top of the plates and mark their location on the pylon.

❑ 6. Remove the mount plates and glue them to the pylon at the location you marked.



❑ 7. Glue the pylon mount plate to the pylon. **Hint:** Insert a pin through both sets of the dimples on the pylon to set the pylon mount in the proper location. Test fit the release mechanism and cut a notch in the pylon to clear the manual release tab.

❑ 8. Drill a 1/8" hole in the pylon above the center of the aft pylon mount plate so you can access the #4 screw. Test fit the pylon to the wing. If the tanks are to be releasable in flight and you have installed a release cable, hook the system up and test its operation (guidelines are provided with the drop tanks).

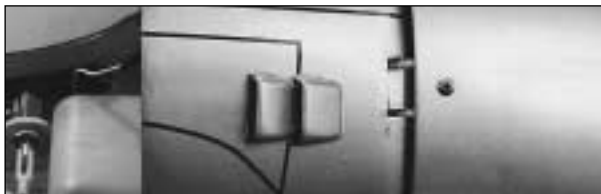

❑ 9. Cut the **Oil Cooler Shutters** and the **Super Charger Exit** along the cut lines. Test fit them to the fuselage at their proper locations as indicated on the plans. **Hint:** For a perfect fit, hold a piece of 220-grit sandpaper on the fuselage and sand the pieces to the correct outline. After the model is covered and it's time to glue them on, hold the part on the fuselage, trace around it with a felt tip pen, remove the covering then glue it directly to the exposed balsa wood.

## INSTALL RECEIVER, SWITCH AND BATTERY

- ❑ 1. After connecting the servos and switch harness to the receiver, wrap it and the battery with 1/4"-1/2" foam rubber to protect them from vibration.
- ❑ 2. Install the **battery** and **receiver** in the fuselage using your preferred method to secure them in position.
- ❑ 3. If you didn't make provisions for an antenna tube during fuselage construction, insert the receiver antenna into a "pushrod guide tube" (not included) and tape it securely to the tube at the exit point. Slide the tube into the rear of the fuselage, then glue it in position with a few blobs of silicone adhesive.

## FINAL HOOKUPS AND CHECKS

- ❑ 1. Make sure the control surfaces move in the proper direction as illustrated (see sketch below).

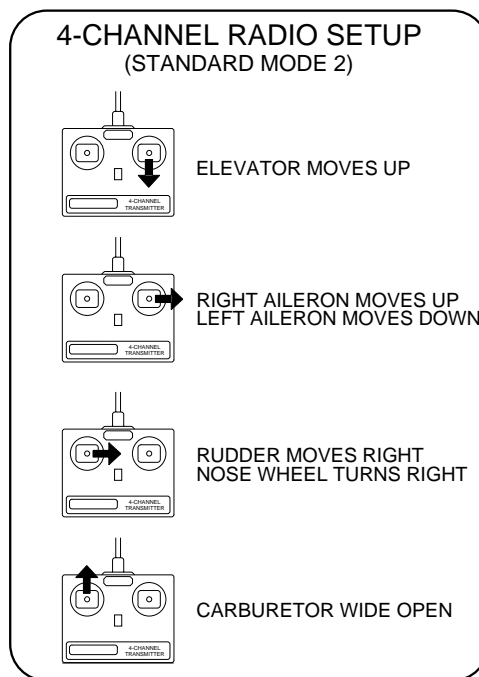

- ❑ 2. Adjust your pushrod hookups as necessary to provide the proper control surface movements as shown.

## CONTROL SURFACE THROWS

We recommend the following control surface throws:

**NOTE:** Throws are measured at the **widest part** of the elevators, rudder, and ailerons.

<b>ELEVATOR:</b>	(High Rate)	(Low Rate)
	11/16" up	7/16" up
	11/16" down	7/16" down

<b>RUDDER:</b>	(High Rate)	(Low Rate)
	1-3/8" right	1" right
	1-3/8" left	1" left

<b>AILERONS:</b>	(High Rate)	(Low Rate)
	9/16" up	3/8" up
	9/16" down	3/8" down

<b>FLAPS:</b>	(Takeoff)	(Landing)
	7/8" down	2-1/8" down

### TRIM MIXING

If your transmitter is programmable for Flap to Elevator mixing we determined during our flight tests that attitude control was slightly smoother with 1/16" of **down** Elevator trim at full Flaps.

**NOTE:** If your radio does not have "dual rates," then set up the control surfaces to move at the **high rate** throws.

**The balance and surface throws for this aircraft have been extensively tested. We are confident that they represent the settings at which the P-47 flies best. Please set up your aircraft to the specifications listed above. If, after a few flights, you would like to adjust the throws to suit your tastes, that is fine. Most warbirds such as the P-47 have large elevators and do not require much throw. Too much throw can create unexpected maneuvers, so remember... "more is not better."**

## BALANCE YOUR MODEL

**NOTE: This section is VERY important and must NOT be omitted! A model that is not properly balanced will be unstable and possibly unflyable.**

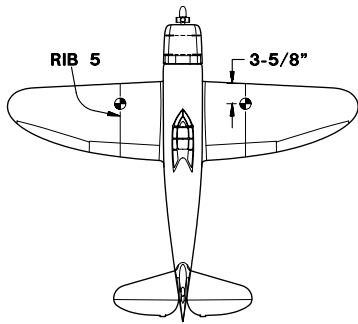

□ 1. Accurately mark the balance point on the **top** of the wing on both sides of the fuselage. The balance point is shown on the plan (**CG**), and is located **3-5/8" back from the leading edge at the location of rib #5** as shown in the sketch and on the plans. **Hint:** Use the full-size wing plan to help you accurately locate the proper balance point on the wing. This is the balance point at which your model should balance for your first flights. Later, you may wish to experiment by shifting the balance up to **5/16" forward or back** to change the flying characteristics. Moving the balance **forward** may improve the smoothness and arrow-like tracking, but it may then require more speed for takeoff and make it more difficult to slow down for landing. Moving the balance **aft** makes the model more agile with a lighter and snappier "feel" and often improves knife-edge capabilities. In any case, **please start at the location we recommend and do not at any time balance your model outside the recommended range.**

□ 2. With the wing attached to the fuselage, all parts of the model installed (ready to fly), an **empty** fuel tank and the landing gear down (extended) hold the model upside-down with the stabilizer level.

□ 3. Lift the model at the balance point. If the tail drops when you lift, the model is "tail heavy" and you must add weight\* to the nose to balance. If the nose drops, it is "nose heavy" and you must add weight\* to the tail to balance. **NOTE:** Nose weight may be easily installed by using a Heavy Spinner Hub or gluing lead weights into the engine compartment. Tail weight may be added by using Great Planes (GPMQ4485) "stick-on" lead weights, and later, if the balance proves to be OK you can open the fuse bottom and glue these permanently in position.

*\*If possible, first attempt to balance the model by changing the position of the receiver battery and receiver. If you are unable to obtain balance by doing so, **then** it will be necessary to add weight to the nose or tail to achieve the proper balance point.*

## PREFLIGHT

### CHARGE THE BATTERIES

Follow the battery charging procedures in your radio instruction manual. You should **always** charge your transmitter and receiver batteries the night before you go flying, and at other times as recommended by the radio manufacturer.

### FIND A SAFE PLACE TO FLY

The best place to fly your R/C model is an AMA (Academy of Model Aeronautics) chartered club field. Ask your hobby shop dealer if there is such a club in your area and join. Club fields are set up for R/C flying and that makes your outing safer and more enjoyable. The AMA also can tell you the name of a club in your area. We recommend that you join AMA and a local club so you can have a safe place to fly and have insurance to cover you in case of a flying accident. (The AMA address is listed on page 3 of this instruction manual).

If a club and its flying site are not available, you need to find a large, grassy area at least 6 miles away from any other R/C radio operation like R/C boats and R/C cars and away from houses, buildings and streets. A schoolyard may look inviting but it is too close to people, power lines and possible radio interference.

## GROUND CHECK THE MODEL

If you are not thoroughly familiar with the operation of R/C models, ask an experienced modeler to check to see that you have the radio installed correctly and that all the control surfaces do what they are supposed to. The engine operation also must be checked and the engine "broken-in" on the ground by running the engine for at least two tanks of fuel. **Follow the engine manufacturer's recommendations for break-in.** Check to make sure all screws remain tight, that the hinges are secure and that the prop is on tight.

## RANGE CHECK YOUR RADIO

Wherever you do fly, you need to check the operation of the radio before every time you fly. This means with the transmitter antenna collapsed and the receiver and transmitter on, you should be able to walk at least 100 feet away from the model and still have control. Have someone help you. Have them stand by your model and, while you work the controls, tell you what the various control surfaces are doing.

Repeat this test **with the engine running** at various speeds with an assistant holding the model. If the control surfaces are not always acting correctly, **do not fly!** Find and correct the problem first.

## ENGINE SAFETY PRECAUTIONS

**NOTE: Failure to follow these simple safety precautions may result in severe injury to yourself and others.**

Keep all engine fuel in a safe place, away from high heat, sparks or flames, as fuel is very flammable. Do not smoke near the engine or fuel; and remember that the engine exhaust gives off a great deal of deadly carbon monoxide. Therefore **do not run the engine in a closed room or garage.**

Get help from an experienced pilot when learning to operate engines.

Use safety glasses when starting or running engines.

Do not run the engine in an area of loose gravel or sand; as the propeller may throw such material in your face or eyes.

Keep your face and body as well as all spectators away from the plane of rotation of the propeller as you start and run the engine.

Keep items such as these away from the prop: loose clothing, shirt sleeves, ties, scarfs, long hair or loose objects (pencils, screw drivers) that may fall out of shirt or jacket pockets into the prop.

Use a "chicken stick" device or electric starter; follow instructions supplied with the starter or stick. Make certain the glow plug clip or connector is secure so that it will not pop off or otherwise get into the running propeller.

Make all engine adjustments from **behind** the rotating propeller.

The engine gets hot! Do not touch it during or after operation. Make sure fuel lines are in good condition so fuel will not leak onto a hot engine causing a fire.

To stop the engine, cut off the fuel supply by closing off the fuel line or follow the engine manufacturer's recommendations. Do not use hands, fingers or any body part to try to stop the engine. Do not throw anything into the prop of a running engine.

## AMA SAFETY CODE

Read and abide by the following Academy of Model Aeronautics Official Safety Code:

### GENERAL (Excerpt)

1. I will not fly my model aircraft in sanctioned events, air shows, or model flying demonstrations until it has been proven to be airworthy by having been previously successfully flight tested.

2. I will not fly my model aircraft higher than approximately 400 feet within 3 miles of an airport without notifying the airport operator. I will give right of way to, and avoid flying in the proximity of

full scale aircraft. Where necessary an observer shall be used to supervise flying to avoid having models fly in the proximity of full scale aircraft.

3. Where established, I will abide by the safety rules for the flying site I use, and I will not willfully and deliberately fly my models in a careless, reckless and/or dangerous manner.

7. I will not fly my model unless it is identified with my name and address or AMA number, on or in the model.

9. I will not operate models with pyrotechnics (any device that explodes, burns, or propels a projectile of any kind).

## RADIO CONTROL

1. I will have completed a successful radio equipment ground check before the first flight of a new or repaired model.

2. I will not fly my model aircraft in the presence of spectators until I become a qualified flier, unless assisted by an experienced helper.

3. I will perform my initial turn after takeoff away from the pit or spectator areas, and I will not thereafter fly over pit or spectator areas, unless beyond my control.

4. I will operate my model using only radio control frequencies currently allowed by the Federal Communications Commission...

## FLYING



The Top Flite P-47 Thunderbolt is a great-flying sport scale airplane that flies smoothly and predictably, yet is highly maneuverable. Compared to other warbirds, its flight characteristics are very smooth and forgiving. It does not, however, have the self-recovery characteristics of a primary R/C trainer; therefore, you must either have mastered the basics of R/C flying or obtained the assistance of a competent R/C pilot to help you with your first flights.

**TAKEOFF:** If you have dual rates on your transmitter, set the switches to "high rate" for takeoff, especially when taking off in a crosswind. Although this model has excellent low speed characteristics, you should always build up as much speed as your runway will permit before lifting off, to give you a safety margin in case of a "flame-out." When you first advance the throttle and the tail begins to lift, the plane will start to turn left (a characteristic of all "tail draggers"). Be ready for this, and correct by applying a slight amount of right rudder to steer it straight down the runway. Be **sure** to allow the tail to come up. Don't hold the tail on the ground with too much up elevator, as the Thunderbolt will become airborne prematurely and will possibly stall. When the plane has sufficient flying speed, lift off by smoothly applying up elevator (don't "jerk" it off to a steep climb!), and climb out gradually. Do **not** use flaps for your initial takeoff. After you have the feel of the Thunderbolt, takeoffs may be made with the flaps set at 50%.

**CAUTION (THIS APPLIES TO ALL R/C AIRPLANES):** If, while flying, you notice any unusual sounds, such as a low-pitched “buzz,” this may be an indication of control surface “flutter.” Because flutter can quickly destroy components of your airplane, any time you detect flutter you must **immediately** cut the throttle and land the airplane! Check all servo grommets for deterioration (this will indicate which surface fluttered), and make sure all pushrod linkages are slop-free. If it fluttered once, it probably will flutter again under similar circumstances unless you can eliminate the slop or flexing in the linkages. Here are some things which can result in flutter: Excessive hinge gap; Not mounting control horns solidly; Sloppy fit of clevis pin in horn; Elasticity present in flexible plastic pushrods; Side-play of pushrod in guide tube caused by tight bends; Sloppy fit of Z-bend in servo arm; Insufficient glue used when gluing in the elevator joiner wire or aileron torque rod; Excessive flexing of aileron, caused by using too soft balsa aileron; Excessive “play” or “backlash” in servo gears; and Insecure servo mounting.

**FLYING:** We recommend that you take it easy with your Thunderbolt for the first several flights, gradually “getting acquainted” with this realistic warbird as your engine gets fully broken-in. Add and practice one maneuver at a time, learning how she behaves in each. For ultra-smooth flying and normal maneuvers, we recommend using the “low rate” settings as listed on page 51. “High rate” elevator may be required for crisp snap rolls and spins. “High rate” rudder is best for knife edge. **Speed** is the key to good knife-edge performance.

**LANDING:** When it’s time to land, fly a normal landing pattern and approach. The Thunderbolt will probably bleed off airspeed more rapidly than the sport planes you are accustomed to. For this reason, keep a few clicks of power on until you are over the runway threshold. For your first landings, plan to land slightly faster than stall speed and on the main wheels, as this is the easiest way to land your P-47. Later, with a little technique, you will find you can make slow, 3-point landings.

Full flaps make the Thunderbolt very steady in the landing pattern, but carry a little extra power to make up for the extra drag. The extra drag of the flaps also allows you to make shorter, steeper approaches. Touch and go’s and go-arounds can be accomplished with full flaps, but be ready to use a little more up elevator. It is preferred to have the flaps up or at half setting for takeoffs and climb-outs because the plane will accelerate and climb much better.

**Have a ball! But always stay in control and fly in a safe manner.**

**GOOD LUCK AND GREAT FLYING!**

*If you enjoyed building the Top Flite P-47 Thunderbolt, try one of these other outstanding .60 size Gold Edition kits as your next project.*



(TOPA0300) Top Flite Cessna 182 Skylane  
81" Wingspan, 10 - 12 Lbs.



(TOPA0130) Top Flite AT-6 Texan  
69" Wingspan, 7.5 - 10 Lbs.



(TOPA0110) Top Flite P-51D Mustang  
65" Wingspan, 8 - 10 Lbs



(TOPA0120) Top Flite P-40E Warhawk  
64" Wingspan, 8 - 10.5 Lbs



(TOPA0100) Top Flite F4U Corsair  
62" Wingspan, 7 - 9.5 Lbs.

Remove shaded area for Century Jet Models retract units.

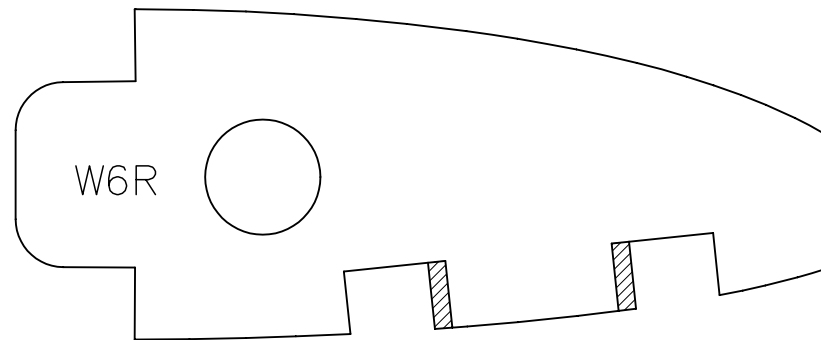
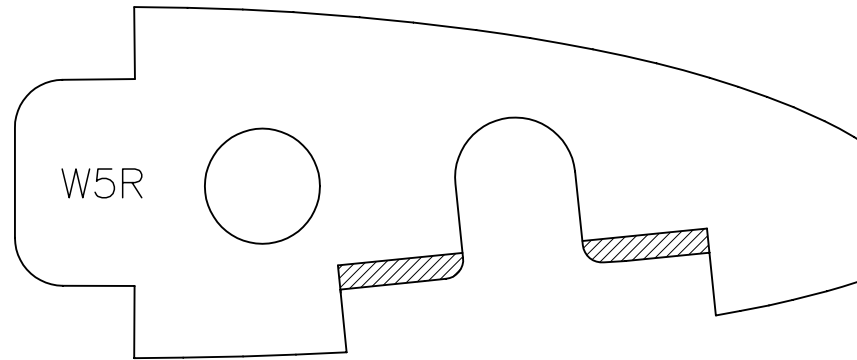

### THREE-VIEW DRAWING

Use this layout for trim scheme planning only. Not suitable for scale documentation.

