

INSTRUCTIONS FOR SUPERTIGRE S-2500 AND LARGER

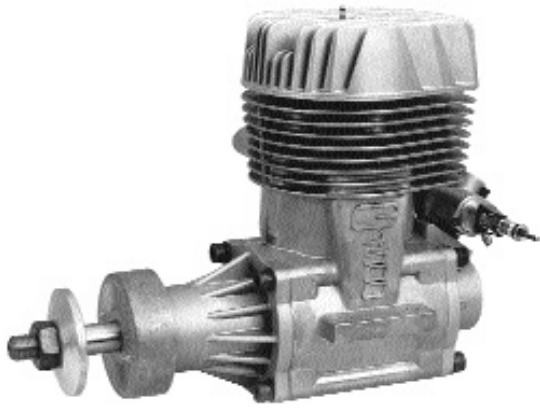

Important:

Please read and follow this instruction manual before operating your engine. These instructions have been written so that you may get the greatest satisfaction from the operation of your SuperTigre engine. All SuperTigre engines are designed for outstanding performance, and manufactured in a modern plant located outside of Bologna, Italy. This factory is dedicated to the production of model engines from .11 cu. in. (1.7 c.c.) displacement all the way up to 3.6 cu. in. (60 c.c.) displacement. All SuperTigre engines are manufactured with the latest computer-controlled machinery to insure their high quality. SuperTigre engines have appeared worldwide in competitions from local club events all the way up to World Championship competition. It's not uncommon to see a SuperTigre engine in the winners' circle wherever models are flown.

Entire Contents © Copyright, 1995

the cylinder head provide a cooling surface. The cylinder head also holds the glow plug.

Glow Plug: The glow plug provides the heat needed to ignite the fuel in the cylinder.

Exhaust Manifold: The exhaust manifold allows the adjustment of the distance from the muffler to the engine.

Muffler: The muffler quiets and directs the exhaust after it exits the cylinder.

Pressure Fitting: A tube is connected from the pressure fitting to the fuel tank. When the engine is running, pressure from the muffler is used to pressurize the fuel tank.

Parts Of The Carburetor

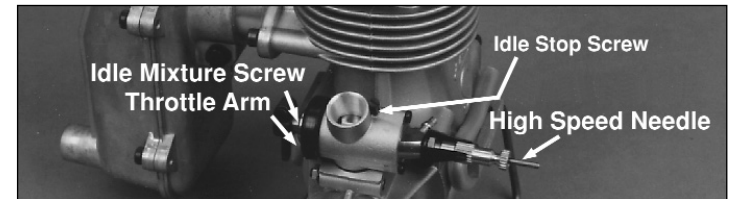

High Speed Needle: The high speed needle controls the amount of fuel entering the carburetor during medium and high speed operation.

Idle Mixture Screw: The idle mixture screw controls the amount of fuel entering the carburetor while the engine is idling.

Idle Stop Screw: The idle stop screw controls how far the throttle barrel closes. We suggest that it be set to allow the throttle barrel to close completely to enable stopping the engine by the throttle trim on the transmitter.

Throttle Arm: The throttle arm is connected to the carburetor barrel. By moving the throttle arm, the barrel is opened and closed. This regulates the speed of the engine.

Parts Of The Engine

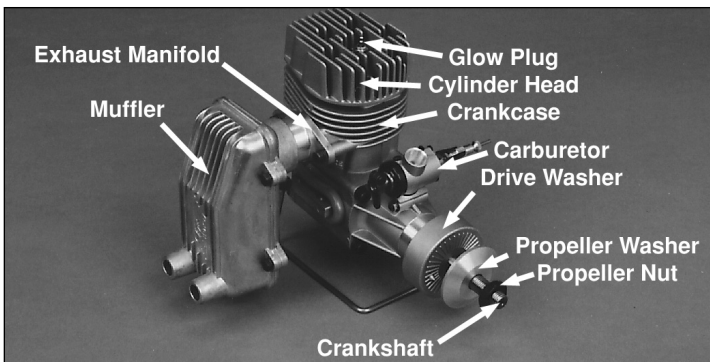

Crankshaft: The crankshaft transforms the reciprocating motion of the piston into rotational motion. The propeller is mounted on the portion of the crankshaft protruding from the crankcase. The portion of the crankshaft protruding past the drive washer is known as the "prop shaft."

Propeller Nut: The propeller nut secures the propeller to the crankshaft.

Propeller Washer: The propeller washer provides a larger, stronger surface area to apply pressure to the propeller.

Drive Washer: The drive washer is keyed to the crankshaft and is knurled on one face to provide a non-slip contact surface for the propeller.

Carburetor: The carburetor controls the amount of fuel and air that enters the engine.

Crankcase: The crankcase is the main body of the engine that houses the internal parts.

Cylinder Head: The cylinder head is mounted on top of the crankcase. It provides a seal at the top of the cylinder. The fins on

Carburetor Installation

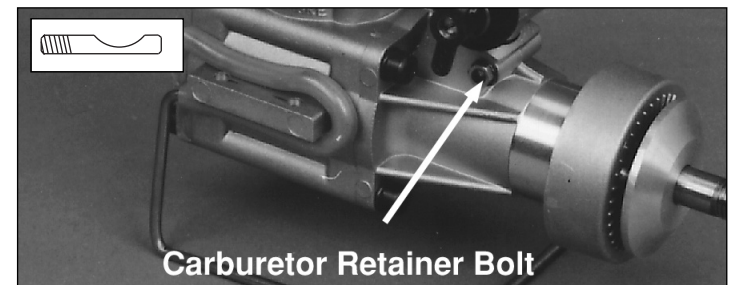

Insert the carburetor retaining bolt (the bolt has a curved area removed from its center) into the hole in front of the carburetor opening. Rotate the retaining bolt so that the removed area in the bolt matches the curve of the carburetor opening. Install the split washer and the brass nut on the threaded end of the bolt. Insert the carburetor in the carburetor opening and press down on the carburetor while tightening the nut.

Engine Installation

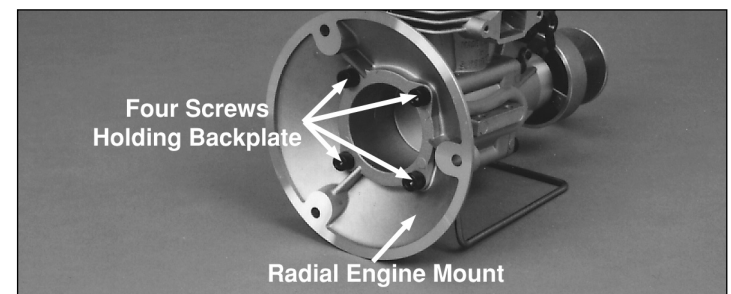

If the engine is to be mounted on the radial mount provided with the engine, remove the four screws holding the backplate. Remove the rubber O-ring on the backplate and install it on the radial mount. Attach the radial mount to the engine using the four longer screws

and split washers provided. Install the radial mount to the firewall of the airplane with three 8-32 screws, three split washers and three blind nuts. (Not Included).

If the engine is to be mounted on wood beams built into the airplane, the beams must be rigid, and parallel with each other, with the top surfaces in the same plane.

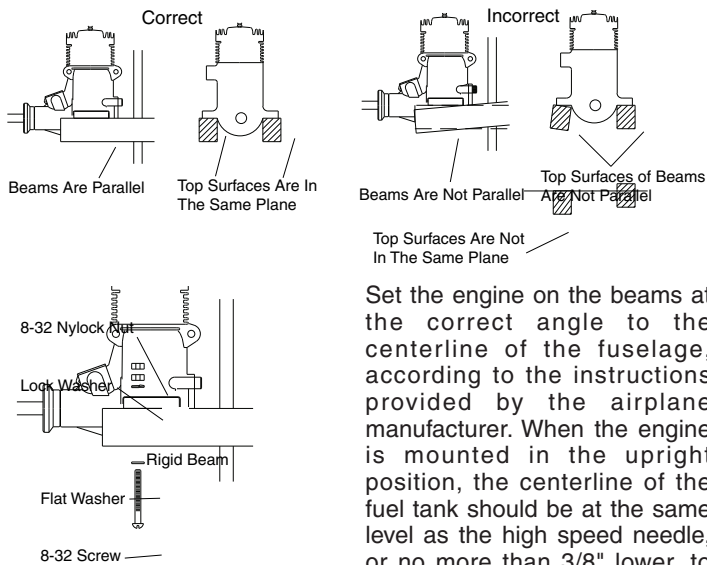

Set the engine on the beams at the correct angle to the centerline of the fuselage, according to the instructions provided by the airplane manufacturer. When the engine is mounted in the upright position, the centerline of the fuel tank should be at the same level as the high speed needle, or no more than 3/8" lower, to

insure proper fuel flow. When the engine is mounted on its side, the centerline of the fuel tank should be at the same level as the center of the intake in the carburetor, or no more than 3/8" lower, to insure proper fuel flow. Mark on the beam the locations of the four mounting holes. If mounting the engine on wooden beams, drill four 11/64" holes through the beams perpendicular to the top surface of the beams. Secure the engine to the beams with 8-32 screws, flat washers, lock washers and 8-32 Nylock nuts.

If mounting the engine on a metal or fiberglass engine mount, follow the manufacturer's mounting instructions. If they did not provide instructions, drill and tap the engine mount to accept 8-32 screws and lock washers installed through the engine mounting flanges and into the engine mount.

Note: Some airplane kits require a slight amount of "right thrust." This is done by angling the engine to the right to counteract the engine torque. Follow the kit manufacturer's instructions to incorporate the correct amount of right thrust if required.

Muffler Installation

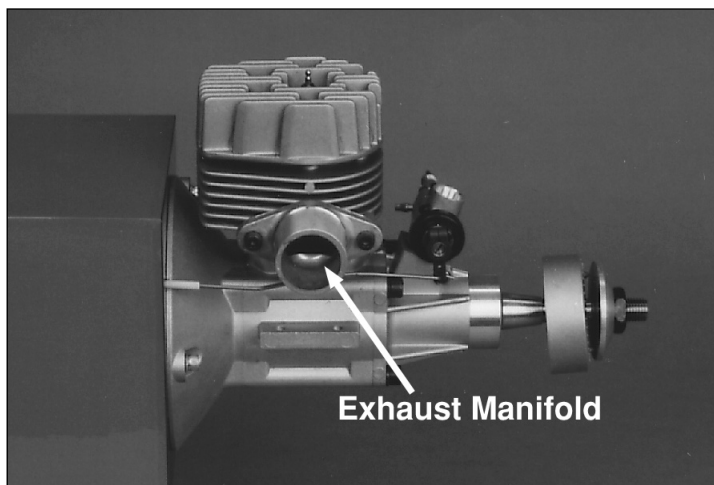

Use two 4mm-.7 size screws and split washers to attach the exhaust manifold to the engine. Make sure to install the gasket between the manifold and the engine and tighten the screws securely.

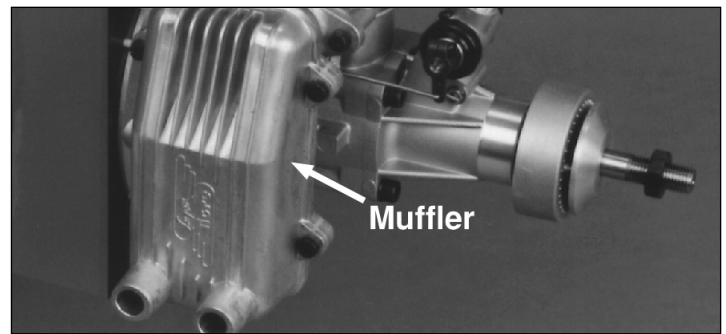

Install the 5mm-.8 screw, split washer and 5mm nut in the muffler, but do not tighten. Slide the muffler over the exhaust manifold and position it so that it does not touch the fuselage. Also, to reduce drag it is best to position the muffler parallel to the fuselage. When the muffler is positioned correctly, tighten the 5mm-.8 screw to clamp the muffler over the exhaust manifold.

Pressure Line Installation



For the engine to operate properly at any angle, the carburetor requires constant fuel pressure. When the engine is running, pressure is created in the muffler by the exhaust. Some of this pressure is used to pressurize the fuel tank. This pressure is provided by a tube from a pressure fitting on the muffler to the vent tube in the fuel tank. Although not absolutely necessary, pressurizing the fuel tank with muffler pressure will provide more consistent running, and will help to maintain more consistent fuel flow during maneuvers. To install the pressure fitting, install the gasket washer on the threaded end of the pressure fitting. Screw the pressure fitting into the threaded hole, near the hole for the exhaust manifold, in the muffler.

Fuel Line Installation

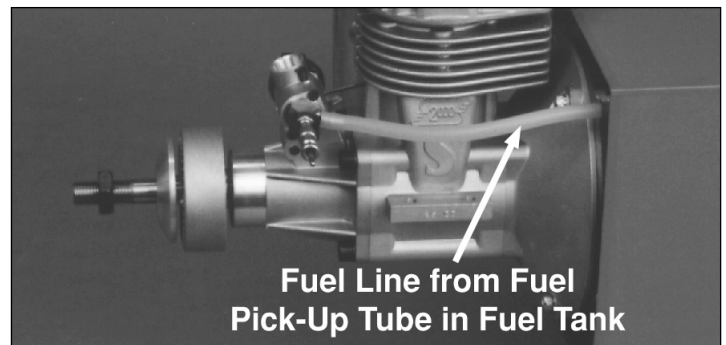

Connect a medium or large size silicone fuel line from the fuel inlet on the carburetor to the fuel pick-up tube that is connected to the clunk in the fuel tank. We suggest that a fuel filter be installed in the fuel line between the carburetor and the fuel tank. The filter will prevent any contaminants in the fuel from clogging the carburetor and doing damage to the internal parts of the engine.

Equipment Required to Operate The Engine

High Quality Fuel: During the break-in process, your large SuperTigre engine requires a fuel with at least 15% oil content by volume. The exact type of oil is not critical...it can be all-synthetic, all-castor, or castor/synthetic blend, but do not go below 15% oil content. If the oil content of the fuel cannot be determined, use a quality 2-stroke fuel with a nitromethane content of 5%-10%.

The break-in fuel must be used until the engine is well broken-in. Since an engine will break-in over the first few gallons of fuel, run your engine on the 15% oil fuel for at least two gallons' worth.



After the engine is broken-in with 2 gallons of fuel containing 15% oil, you can use a fuel that has as low as 10%-12% oil content by volume. The oil can be all-castor, all-synthetic, or a castor/synthetic blend. Many fuels blended as "Super-T", "S.T." or "SuperTigre" fuels are fuels with low oil content. **Be careful** in selecting your fuel. Some fuels contain less than 10% oil. You must be careful setting the high-speed needle when you use fuels with low oil content, because there is less margin for error if you get a slightly lean run.

Do not use fuel with low oil content for break-in running! If you use a fuel with low oil content for break-in running, there's a good chance that the connecting rod will seize to the crankshaft from lack of sufficient lubrication. This will almost always require replacement of the connecting rod and crankshaft, which is not a warranty repair.

Fuel Pump: We recommend a Hobbico (HCAP3100) electric fuel pump that can be operated from a 12V battery. If you do not have a 12V battery, we recommend a Hobbico Hand Operated Fuel Pump (HCAP3010).



Propeller: Choose a propeller for initial running from the propeller chart under the heading "break-in." After the engine has been broken in, you can use that propeller for flying, or choose one of the propellers on the chart listed under "flying."

In the case of all of the large SuperTigre engines, peak RPM is what determines the propeller you should use. These engines usually run best when peak RPM is limited to between 7,300 and 7,800 RPM, and the S-2500 can run as high as 8,000 RPM. These RPM figures are taken with the engine running at full throttle, on the ground.

Any propeller which gives you the desired static RPM and also gives you the flight performance you want from your airplane is a correct propeller. As a rule, lower-pitched props give you better takeoff acceleration and climb, while higher-pitched props will give you higher aircraft speed in the air. You want to select a prop that gives you the best compromise between takeoff, climb, and airspeed. The prop chart gives some props that have worked out for most modelers.

Adjustable Wrench or Open-End Wrench: A wrench will be required to install and remove the propeller nut.



Chicken Stick or Electric Starter: Again, if a 12V battery is used, we recommend a Hobbico TorqMaster 180 Starter (HCAP3300). If you do not have a 12V battery, a chicken stick can be used to flip the propeller to start the engine. **Caution: never use your finger to flip the propeller.** If the engine should backfire, the propeller could injure your finger.

Glow Plug Battery: For safety and ease of operation, we recommend a Hobbico Glow Plug Clip (HCAP2505) with the self-contained battery. If using a Hobbico Locking Glow Plug Clip (HCAP2500) connected to a power panel on a field box, make sure the wires are behind the propeller when starting the engine.



Glow Plug: A general-purpose R/C Long glow plug in your SuperTigre engine, will work just fine in most cases.

Glow Plug Wrench: The glow plug will eventually fail to retain heat or it will need to be removed to clear a flooded engine. We recommend a Hobbico 4-Way Wrench (HCAP2550) that can be used to remove the glow plug.



General Information

Your SuperTigre engine is a two-stroke engine that works on a semi-diesel principle. The fuel is a mixture of methanol, castor or synthetic oil, and nitromethane. This fuel is ignited in the engine by a combination of compression heating and the catalytic action of a glow plug. The glow plug must be initially heated by using a glow plug battery, which is disconnected once the engine is running. The glow plug requires 1.2-1.5V to glow properly. There are many glow plug batteries and connectors on the market that will do the proper job of heating the glow plug. Once the engine is started, the heat of combustion will keep the glow plug hot. Your SuperTigre engine uses a piston ring. The break-in process is critical in getting the parts to "wear in" and fit properly so that the engine will develop proper performance and useful life.

Initial Setup

Check your glow plug by briefly attaching the glow plug battery to the plug – the plug must glow brightly.

1. To install the glow plug in the engine, first slide the compression washer onto the glow plug. Carefully screw the glow plug into the top of the cylinder head with your fingers. Tighten the glow plug "finger-tight," then use a glow plug wrench to tighten the glow plug securely. Do not over-tighten the glow plug or the threads in the cylinder head may strip.

2. Locate the correct propeller for your airplane from the chart below:

Engine	Break-in	Flying
S-2500	18x8	18x6, 18x8
S-3000	18x10	18x8, 18x10, 20x6, 20x8
G4500	20x8	20x8, 20x10, 22x8
60 c.c. Twin	22x10	22x10, 24x8

Ream the propeller hole to the appropriate diameter using a Great Planes Prop Reamer (GPMQ5005). Balance your propeller using a prop balancer such as the (TOPQ5700) Top Flite Precision Magnetic Balancer. To install the propeller on the engine, remove the propeller nut and propeller washer. If installing a spinner, install the spinner backplate first, following the manufacturer's instructions. Next, install the propeller with the rounded surface of the propeller blade facing forward. Install the flat side of the propeller washer against the propeller. Thread the propeller nut against the propeller washer, but do not tighten it. Rotate the crankshaft of the engine counterclockwise to the compression stroke (the crankshaft will become difficult to turn).

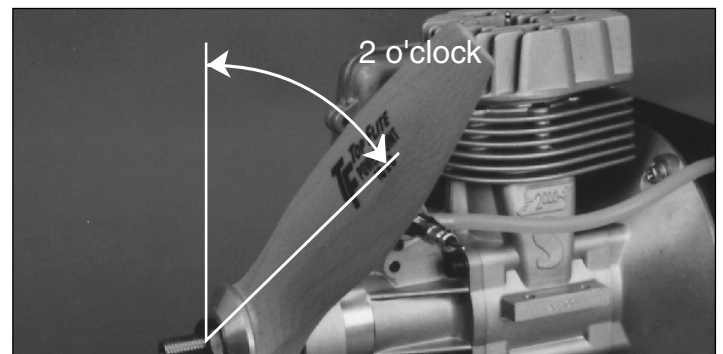

Continue rotating the propeller until it's at the 2 o'clock position, then tighten the propeller nut **securely** against the propeller washer. Some people use a 4-way wrench for this purpose, but it is difficult to get the nut tight enough with that type of wrench. Many modelers use (and we recommend) a 6-inch adjustable wrench for tightening prop nuts.

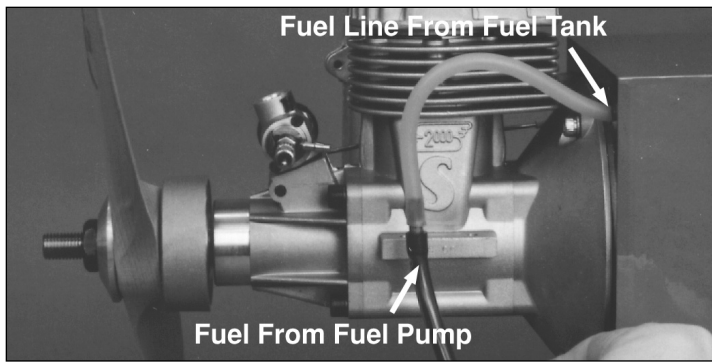

3. Fill the fuel tank by removing the fuel line from the fuel inlet on the carburetor, and connecting it to the fuel tubing from the fuel pump. Remove the pressure line from the pressure fitting on the muffler and aim it at the ground where you want the overflow fuel to spray. Environmentally conscious modelers direct this fuel into an "overflow bottle." Start filling the fuel tank. When the tank is full, fuel will overflow out the pressure line. Disconnect the fuel pump from the fuel line and reconnect it to the carburetor. Reconnect the pressure line to the muffler.

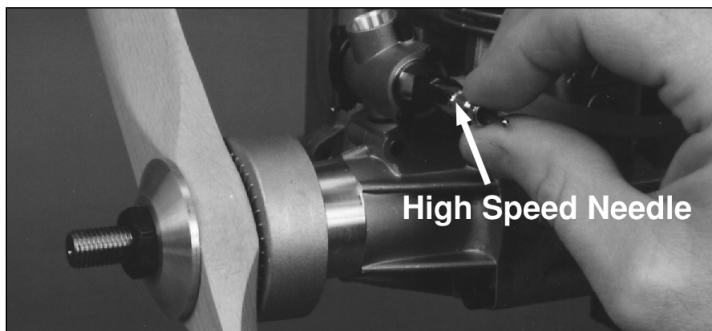

4. Gently turn the high-speed needle valve clockwise until it stops. Do not tighten it. Then open it 4 turns. Turning the high speed needle in a clockwise direction is called "leaning" the mixture, and turning it counterclockwise is called "richening" the mixture.

Do not worry about the setting of the idle mixture screw at this time. It has been set close to the proper setting by the factory.

CAUTION: When running the engine make sure you have plenty of ventilation. Model exhaust fumes are just as deadly as automobile fumes. Wear hearing protection when you're operating your engine – the noise is very loud.

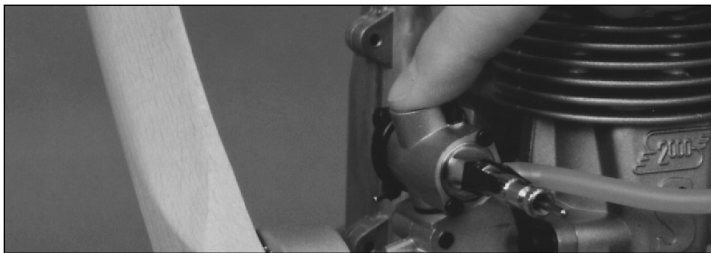

5. Switch on the transmitter, then receiver. Fully open the throttle. Do not attach the starting battery at this time. Place a finger over the carburetor intake and turn the propeller over several times (counterclockwise). Watch the fuel line. You will see the fuel come up to the carburetor. Once the fuel reaches the carburetor, turn the engine two more revolutions. Remove your finger from the carburetor intake, and briskly flip the propeller to work the fuel into the cylinder. This process is called "choking" the engine.

Initial Running and Break-In

Have an assistant hold the airplane securely from behind the wing to prevent the airplane from moving forward. You will see some modelers starting their engine with one hand while holding their airplane with the other. This is an unsafe practice that greatly increases the chances of having an accident.

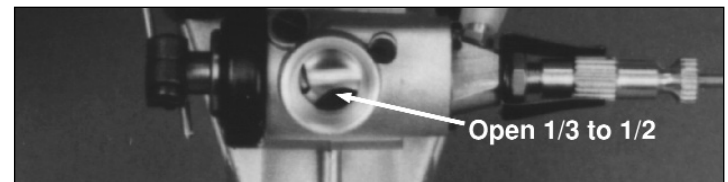

Close the throttle to about 1/3-1/2 open.

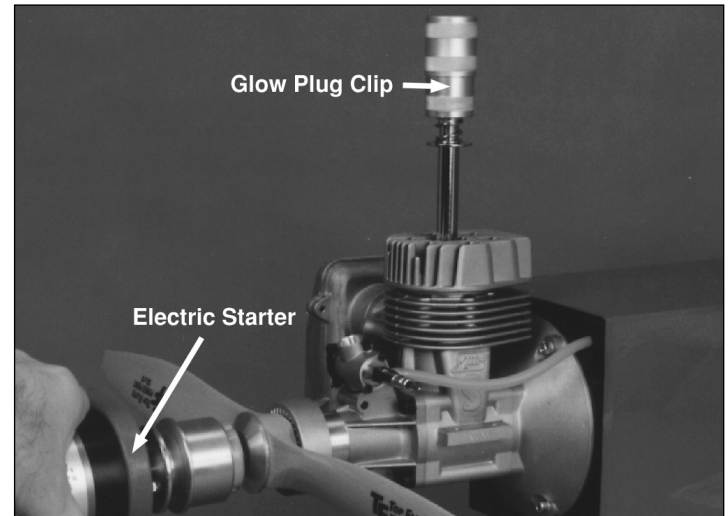

Securely attach the glow plug clip to the glow plug. If using a glow plug clip connected to the power panel of a field box, make sure the wire cannot become entangled in the propeller.

If using a heavy-duty "chicken stick" to start the engine, flip the propeller clockwise (backwards) using quick flips. Some engines start easily with a chicken stick. Others do not. If the engine fails to start after 10 flips, it may not have enough fuel. **Remove the glow plug clip** and repeat the choking process. If the propeller becomes difficult to rotate, the engine is flooded with fuel. Remove the glow plug and turn the airplane upside down (pointing away from you) and flip the propeller backwards a few times, allowing the excess fuel to drain out. Reinstall the glow plug, attach the glow plug clip and try starting the engine again. **Do not under any circumstances attempt to start the engine using only your finger.**

If using an electric starter to start the engine, make sure the starter will turn the propeller counterclockwise. If your engine has a spinner on it, place the large opening of the rubber adapter on your starter against the spinner. Switch the starter on and hold it against the spinner until the engine starts. You may need to switch the starter on first and "bump" the spinner with the rubber adapter to get it started the first few times. If only a propeller nut is on the front of the propeller, turn the rubber adapter around on the starter and center the small hole of the rubber adapter over the nut. Switch the starter on and hold it against the propeller until the engine starts. If the starter has difficulties turning the engine, the engine may be flooded with fuel. Clear the engine of fuel as described above. **Do not** continue to try starting a flooded engine. The connecting rod in the engine could be damaged.

The engine should start and keep running, although it may be running slightly rough at this time. This is normal. Allow the engine to warm up for 15 to 20 seconds before removing the glow plug clip. Let the engine run at this throttle setting for 30 seconds and then open the throttle to full.

The engine should be running at full-throttle, but be running somewhat rough, with a lot of oil being discharged from the exhaust port. This is because the engine is running in a very rich condition...that is, more fuel is running through the engine than is needed. Run the engine at this setting.

After ten to fifteen minutes, you can start leaning the engine by turning the high-speed needle clockwise. Never turn the needle more than 1/8 of a turn at this point. To determine if the engine will accept having the needle leaned, give the fuel line a quick pinch and release...just pinch the fuel line and let go. You should hear the

engine increase a bit in RPM, with the sound going up in pitch. If the engine increases in RPM, you can lean 1/8 of a turn. Allow the engine to run for several minutes at this setting. Now give the fuel line a quick pinch and release. Wait a minute and do it again. Do this five times. If the RPM increases all five times, lean the high-speed needle another 1/8 of a turn. Wait one minute, and then start the pinch and release series again. If the engine doesn't increase in RPM when you pinch and release, wait one minute before you try the pinch and release series again. Don't lean the high-speed needle until you get an increase in RPM every time you pinch and release the fuel line.

Keep repeating the "pinch and release" method until the RPM does not change when you pinch the line. At this point, you've leaned the engine as far as possible. Do not ever lean the engine to the point that the RPM decreases when you pinch the line. For flying, you want to set the high-speed needle so that you get an increase in RPM when you pinch the line or when you point the nose of your model straight up.

If you hear the engine's RPM decrease when you pinch and release, you must immediately turn the high speed needle counterclockwise at least 1/2 turn. The drop in RPM tells you that the engine is too lean, and needs to be run at a richer setting for at least a few more minutes. Don't be in a hurry to lean your engine to peak RPM. Be conservative, and take your time. Running richer longer will not hurt your engine a bit. You may have to spend an hour running your engine on the ground before you can fly it. A careful, conservative break-in will only insure a good, long useful life for your engine.

Idle Mixture Setting

The idle mixture is adjusted with the brass screw that's located in the center of the throttle arm. It operates in the same manner as the high-speed needle use: turning it clockwise leans the idle mixture, and turning it counterclockwise richens the idle mixture.

The basic adjustment of the idle mixture screw has been set by the factory, and should require little adjustment, if any. Use the same "pinch and release" method to determine if the idle mixture is rich or lean. You may have to hold the pinch a bit longer than when the engine was running at high speed because fuel flow is slower at low throttle settings.

The best way to adjust the idle mixture is to have the engine running at full-throttle, and slowly close the throttle. Once the engine has been throttled back to below 1/2 throttle, try the pinch and release method. The engine should increase in RPM slightly. This means that you can lean the idle mixture a bit, about 1/8 turn. Reduce the throttle a little more, and repeat. You should be able to work your way down to a nice, low idle. The carburetor barrel will be open about 1/32" to 1/16" when the engine is idling properly.

Stopping The Engine

To stop the engine before it runs out of fuel, we suggest that the radio be set up so that when the transmitter throttle and throttle trim are moved to the low position, the carburetor is completely closed. If your throttle was not set up this way, pinch the fuel line from the fuel tank to the carburetor and hold it until the engine stops.

Restarting The Engine

If the engine is still warm, try to start the engine without choking it first. If the engine has cooled down it may need to be choked.

If the engine does not start after choking, the engine may be flooded. Clear the excess fuel from the engine as previously described. Attach the glow plug clip to the glow plug and check that it glows bright orange. If it does, reinstall it in the engine. If it does not, replace the glow plug with a new one. Try to restart the engine without choking it.

Care And Maintenance

When it's been properly broken-in, your SuperTigre engine should give you several years of reliable service. To make sure it lasts as long as possible, there are a few things you can do to care for it.

- At the end of every flying session, drain the fuel tank completely. Then remove the fuel line from the engine, and attempt to start it. It should start and then run for a short period. Keep trying to start the engine until it just won't fire. You want the engine "dry" of fuel.

- After the engine is dry of fuel, open the throttle to "full" and put several drops of a good-quality "after-run" oil into the engine. Don't have the glow plug clip attached while doing this. Briskly hand-flip the engine, as if you were trying to start it, to make sure the oil is worked into the engine. Repeat the process. Be liberal with the oil. You want to make sure all of the internal parts get well coated. Several manufacturers make specific after-run products to protect your engine between flying sessions. You can make your own after-run oil by mixing Marvel Mystery Oil and automatic transmission fluid in a 50-50 mix. 3-in-1 oil can be used if the engine will only be stored for a very short time – a few days or so. We don't recommend that you use any kind of water dispersant or penetrating oil in your SuperTigre engine. These kinds of oil will loosen any rust and allow it to be dispersed throughout the engine the next time it's run. Rust is iron oxide, which is an abrasive compound. If it is allowed to run through the engine, the parts will lose their proper clearances and performance will be lost.

- For long-term storage, remove the engine from the model and be extremely generous in getting all of the engine parts coated with the after-run oil. Wrap the engine in a plastic bag to keep out moisture and to prevent the oil from drying out.

- Keep your engine clean. Wipe off the outside of the engine with denatured or rubbing alcohol to remove any fuel residue and dirt. If dirt or burned-on fuel residue is allowed to accumulate on the cylinder fins, the engine's cooling ability will be reduced. The dirt or burned-on residue will act as an insulating blanket and prevent proper cooling. This is especially critical in cowled installations. Dirt will also abrade the moving parts if it's allowed to get inside the engine.

- We suggest that a **fuel filter** be installed between the carburetor and the fuel tank to prevent dirt from entering the carburetor.

- Do not disassemble the engine unless you are a qualified to do so.

- Avoid running the engine in dusty conditions. If the area you fly in is dusty, such as a dirt runway, we suggest installing an **air filter** made for airplane engines.

- After flying, check all engine mounting bolts, muffler screws, propeller nut and spinner to make sure they have not loosened up.

Safety Precautions and Warnings

1. Keep all spectators at least 20 feet away when operating the engine.
2. Keep yourself out of the path of the prop. Do not lean over the propeller when starting or adjusting the engine.
3. Always balance the propeller before installing it on the engine. Never use a propeller that is damaged, no matter how slightly.
4. Make sure the edges of the spinner do not touch the propeller blades. The sharp edges may cut into the propeller blades and cause them to break.
5. Be sure your glow plug clip cord will not interfere with the propeller when it's turning.
6. Never use your finger to start the engine. Always use a "chicken stick" or electric starter.
7. Make all engine adjustments from behind the propeller. Always stop the engine before adjusting the idle stop screw or idle mixture screw.
8. Do not operate the engine in an area with loose gravel or sand.
9. Wear safety glasses when starting and running the engine.

10. Keep all loose clothing such as neck ties and shirt sleeves away from the propeller. Remove any objects from your shirt pockets to prevent them from falling into the propeller.
11. Keep all model fuel away from children, sparks and excessive heat. Do not smoke while handling model fuel. Model fuel is highly flammable and must be handled with caution. Model fuel must be stored in a cool, dark place, and kept tightly sealed. Moisture will ruin model fuel.
12. Never operate the model engine in an enclosed area. The engine produces deadly carbon monoxide and must be run in a well ventilated area.
13. Model engines get very hot when running. Do not touch any part of the engine until it cools.

Trouble Shooting

Engine won't fire: Check to make sure the glow plug is glowing brightly. Make sure the engine is getting sufficient fuel. Make sure the engine isn't flooded.

Engine fires, but runs only for a brief time: The engine isn't getting enough fuel. Open the high-speed needle 1/4-1/2 turn. You may have to choke the engine again. Check for kinks in the fuel line.

Engine only "pops" and sputters: The engine is flooded. Remove the glow plug and turn the airplane upside down (pointing away from you), and flip the propeller backwards a few times, allowing the excess fuel to drain out. Reinstall the glow plug.

Engine fires and runs at a very high speed: The high speed needle may be too lean. Open it at least 1/2 turn. The fuel line may have an air leak (especially if the engine will not respond to opening the high-speed needle). The muffler pressure line may have come off of the muffler or the fuel tank. The fuel line may be too small in diameter.

Engine runs for a few minutes and then quits: The high speed needle may be too lean, open it at least 1/2 turn. The fuel tank may be too low. The fuel line may have a kink or an air leak. The propeller may be too large. The fuel is deficient in oil content. The engine isn't getting enough cooling air.

Engine runs backwards: The engine may be flooded or the high speed needle is set too rich. Close the high speed needle 1/8 of a turn.

Repair And Warranty Information

The warranty of your SuperTigre engine is detailed on a separate insert. For all repairs, warranty or non-warranty, your engine can be sent to:

Hobby Services
1610 Interstate Dr.
Champaign, IL 61821
Phone: (217) 398-0007

9:00 A.M. to 5:00 P.M. Central time, Monday through Friday

The Hobby Services staff will be able to help you with any questions about SuperTigre engine repairs or operation.

