

Sd. Kfz. 7

Das Sd.Kfz. 7 – Mittlerer Zugkraftwagen 8 t – war eine der bekanntesten Zugmaschinen der deutschen Wehrmacht im zweiten Weltkrieg. Das Halbkettenfahrzeug wurde vor allem als Artilleriezugmaschine für die schwereren Geschütze wie die 8,8-cm-Flak eingesetzt. Darüber hinaus bot es Platz für zwölf Mann mit Ausrüstung und für weitere Munition der mitgeführten Geschütze.

Das Sd.Kfz. 7 wurde von Krauss-Maffei entwickelt und ab 1938 bis 1944 gebaut. Der Sechszylinder Maybach-Motor leistete 140 PS und beschleunigte das Fahrzeug auf bis zu 50 km/h.

Sd. Kfz. 7

The Sd.Kfz. 7 – an 8 ton medium tractor – was one of the best known infantry vehicles used by the German army in World War II. This half-track was primarily used as an artillery tractor for heavy guns such as the 8.8 cm Flak anti-aircraft gun. It could also carry twelve men with their kit and ammunition for the guns they carried. The Sd.Kfz. 7 was developed by Krauss-Maffei and built between 1938 and 1944. The six-cylinder Maybach engine developed 140 hp and accelerated the vehicle up to 50 km/h.

Form hergestellt und in Eigentum von Revell GmbH & Co. KG. Widerrechtliche Nachahmungen werden gerichtlich verfolgt.
 Ce produit est propriété de la société Revell GmbH & Co. KG. Toute utilisation ou duplication frauduleuse sera l'objet de poursuites en justice.
 Modelado y en propiedad de Revell GmbH & Co. KG. Imitaciones ilícitas serán perseguidas por la ley.
 Forma prodotta dal Revell GmbH & Co. KG. e di proprietà della stessa impresa, la quale procederà legalmente contro ogni imitazione abusiva.
 Malli on Revell GmbH & Co. KG. valmistama ja omaisuutta. Laittoomaan kopiointiin tuliaan puuttumaan oikeudellisin toimin.
 Formen er produsert og eies av Revell GmbH & Co. KG. Etterfigning uten tillatelse vil bli gjenstand for rettslig forfølgelse.
 Produktoğı i prawa własności firmy Revell GmbH & Co. KG. In e-galne podrabianie jest zabron-one pod odpowiedzialnością sądową.
 Model, Revell GmbH & Co. KG. firmasının mülkiyeti altında imal edilmiştir. Kanuna aydın taklidiler malikemuce takip edilecektir.
 A forma efiállitığı és a tulajdonjog betokosa a Revell GmbH & Co. KG. A jogellenes utánzatokat es hamisítványokat bíróságilag üldözök.

Mould manufactured by and property of Revell GmbH & Co. KG. Illegal imitations are subject to prosecution.
 Vorm vervaandigd door en eigendom van Revell GmbH & Co. KG. Onrechtmatige nabootsingen worden gerechtelijk vervolgd.
 Formas produzidas e de propriedade da Revell GmbH & Co. KG. Cópias não autorizadas serão processadas juridicamente como determinado na lei.
 Modelen tillverkad av och tillhör Revell GmbH & Co. KG. All kopiering beivras enligt lagen om upphovsrätt.
 Formen er fremstillet af Revell GmbH & Co. KG. som også her ejendomsret. Lovstridige efterligninger sagsøges.
 Modela izgotovljena i zlastnosti sobstvenosti firme Revell GmbH & Co. KG. Protivzakonno kopiranje presледуется в судебном порядке.
 Η μορφή κατασκευασμένη και διατίθεται στην ιδιοκτησία της Revell GmbH & Co. KG. Οι παρανομιές διπλώσεως θα καταδιώκονται δικαστικώς.
 Tva: byl vyrobená a je v majetku firmy Revell GmbH & Co. KG. a je její vlastností. Proti nezákonným napodobením se bude postupovat soudní cestou.
 Forma je proizvedene in je vlasništvo Revell GmbH & Co. KG. Neovlašćene kopije bodo pravno kažnjene.

Verwendete Symbole / Used Symbols

Bitte beachten Sie folgende Symbole, die in den nachfolgenden Baustufen verwendet werden.

Veillez noter les symboles indiqués ci-dessous, qui sont utilisés dans les étapes suivantes du montage.

Sivanse tener en cuenta los símbolos facilitados a continuación, a utilizar en las siguientes fases de construcción.

Si prega di fare attenzione ai seguenti simboli che vengono usati nei susseguenti stadi di costruzione.

Huomioi seuraavat symbolit, joita käytetään seuraavissa kokoamisvaiheissa.

Legg merke til symbolene som benyttes i monteringsstrinnene som følger.

Proszę zwracać na następujące symbole, które są użyte w poniższych etapach montażowych

Daha sonrakı montaj basamaklarında kullanılabacak olan, aşağıdaki sembollere lütfen dikkat edin.

Kérjük, hogy a következő szimbólumokat, melyek az alábbi építési fokokban alkalmazásra kerülnek, vegyék figyelembe.

Please note the following symbols, which are used in the following construction stages.

Neem a.u.b. de volgende symbolen in acht, die in de onderstaande bouwfasen worden gebruikt.

Por favor, preste atenção aos símbolos que seguem pois os mesmos serão usados nas próximas etapas de montagem.

Observera: Nedanstående piktogram används i de följande arbetsmomenten.

Lag venligst märke till följande symboler, som benyttes i de följande byggfaser.

Пожалуйста, обратите внимание на следующие символы, которые используются в последующих операциях сборки.

Παρακάτω προέεξε τα παρακάτω σύμβολα, τα οποία χρησιμοποιούνται στις παρακάτω βαθμίδες συναρμολόγησης.

Dbejte prosim na dále uvedené symboly, které se používají v následujících konstrukčních stupních.

Prosimo za Vašu pozornost na sledeće simbole ki se uporabljajo v naslednjih korakih gradbe.



Abziehbild in Wasser einweichen und anbringen

Soak and apply decals

Mouiller et appliquer les décalcomanies

Transfer in water even laten weken en aanbrengen

Remojat y aplicar las calcomanías

Recomendado para fijar las calcas

Posição recomendada para aplicar os decalques

Raccomandato per applicare le decalcomanie

Rekommenderas för montering av dekaler

Αποβάλετε ή πλάστετε και τοποθετήστε τη

Καρτρίκι να ποσώνεται με την

Ζαλέσκα δε ποσώνεται kalkomanii

Συνιστάται για την επικόλληση των ετικετών.

Dekallerin yapiştrılmasında kullanılması tavsiye edilir

Připravte na zlepšení přilnavosti oblék

Matrica lägty

Priporočljivo za pritrjevanje nalepk

Odporučane na zlepšene prilnavosti nalepek

RECOMANDAT PENTRU APLICAREA ACTIBILURILOR

Подходящо за фиксация на картинки върху повърхността на модела



Zur Anbringung der Abziehbilder empfohlen

Recommended for affixing the decals

Recommandé pour l'application des décalcomanies

Aanbevelen voor het aanbrengen van de transfers

Recomendado para fijar las calcas

Posição recomendada para aplicar os decalques

Raccomandato per applicare le decalcomanie

Rekommenderas för montering av dekaler

Αποβάλετε ή πλάστετε και τοποθετήστε τη

Καρτρίκι να ποσώνεται με την

Ζαλέσκα δε ποσώνεται kalkomanii

Συνιστάται για την επικόλληση των ετικετών.

Dekallerin yapiştrılmasında kullanılması tavsiye edilir

Připravte na zlepšení přilnavosti oblék

Matrica lägty

Priporočljivo za pritrjevanje nalepk

Odporučane na zlepšene prilnavosti nalepek

RECOMANDAT PENTRU APLICAREA ACTIBILURILOR

Подходящо за фиксация на картинки върху повърхността на модела



Kleben

Glue

Coller

Lijmen

Engomar

Colar

Incollare

Limmas

Limmaa

Limes

Lim

Κλεψτε

Przykleić

κόλλημα

Yapıştırma

Lepeni

ragasztani

Lepiti



Wahlweise

Optional

Facultatif

Naar keuze

No engomar

Alternado

Facoltativo

Vaifrit

Vaihtoehtoisesti

Valgfritt

Valgfritt

Ha valóság

Do wyboru

εναλλακτικά

Seğmeli

Voitlieni

tetszés szerint

način izbire



Bemalen

Paint

Peindre

Beschildern

Pintar

Dipingere

Pintar

Mála

Male

Male

Maalaa

Pomalowaæ

Befesteni

раскрасить

Pomalovat

Boymak

Poslikati

Χρωματισμα



Gleichen Vorgang auf der gegenüberliegenden Seite wiederholen

Repeat same procedure on opposite side

Opérer de la même façon sur l'autre face

Dezelfde handeling herhalen aan de tegenoverliggende kant

Realizar el mismo procedimiento en el lado opuesto

Repetir o mesmo procedimento utilizado no lado oposto

Stessa procedura sul lato opposto

Upprepa proceduren på motsatta sidan

Toista sama toimenpide kuten vieriseällä sivulla

Det samme arbejdet gentages på den modsatliggende side

Gjenta prosedyren på siden tværs overfor

Повторять такую же операцию на противоположной стороне

Taki sam przebieg czynności powtórzyc na stronie przeciwnej

επανάλαβε την ίδια διαδικασία στην απέναντι πλευρά

Aynı işlemi karşı tarafta tekrarlayın

Stejný postup zopakovat na protilehlé straně

ugyanazt a folyamotat a szemben található oldalon megismételni

Isti postopek ponoviti in na suprotni strani



Abbildung zusammengesetzter Teile

Illustration of assembled parts

Figure représentant les pièces assemblées

Afbeelding van samengevoegde onderdelen

Ilustración piezas ensambladas

Figura representando peças encaixadas

Illustrazione delle parti assemblate

Bilden visar dalarna hopsatta

Kuva yhteinelitetyistä osista

Illustrasjonen viser de sammensatte delene

Ilustrasjon, sammensatte deler

Изображение смонтированных деталей

Rysunek złożonych części

απεικόνιση των συναρμολογημένων εξαρτημάτων

Birleştirilen parçaların şekli

Zobrazení sestavených dílů

összeállított alkatrészek ábrája

Slika slopljenega dela



Mit einem Messer abtrennen

Detach with knife

Détacher au couteau

Met een mesje afsnijden

Separarlo con un cuchillo

Separar utilizando uma faca

Staccare col coltello

Skär loss med kniv

Irrota veitsellä

Adskilles med en kniv

Skjær av med en kniv

Отделять ножом

Odciać nożem

διαχωρίστε με ένα μαχαίρι

Bir bıçak ile kesin

Oddélit pomocí nože

kés segítségével leválasztani

Oddéliiti z nožem



Bauteile trocknen lassen

Allow the parts to dry

Laisser sécher les pièces

Oderdelen laten drogen

Dejar secar las piezas

Deixar secar os componentes

Far asciugarsi i componenti

Anna osien kuivua

La delene tørke

Låt byggdelarna torra

Дать деталям высохнуть

Części pozostawić do wyschnięcia

Αφήστε τα μέρη να στεγνώσουν

Yapı parçalarını kurumaya bırakınız

Alkatrészeket hagyja száradni

Jednotlivé díly nechte zaschnout

Pustite da sestavni deli posušijo



Anzahl der Arbeitsgänge

Number of working steps

Nombre d'étapes de travail

Nombre d'étapes de travail

Het aantal bouwstappen

Número de operaciones de trabajo

Número de etapas de trabalho

Numero di passaggi

Antal arbetsmoment

Työvaiheiden lukumäärä

Antall arbejdsstrinn

Antall arbejdsstrinn

Количество операций

Liczba operacji

αριθμός των εργασιών

İş safhalarının sayısı

Počet pracovnich operaci

Številka koraka montaže



Papierbild ausschneiden und ankleben

Cut out paper picture and glue

Découper la photo et la coller

Papiertekening uitknippen en lijmen

Recortar la ilustración de papel y pegarla

Cortar e colar figura de papel

Ritagliare la figura di carta e incollarla

Klipp ut och klistra fast pappersbilden

Leikkaa paperikuva irti ja liimaa kiinni

Papirbilledet skæres ud og påklæbes

Skjær ut papirbilledet og lim det på

Бумажную картинку вырезать и наклеить

Wyciąć obrazek papierowy oraz przykleić

κόψτε τη φωτογραφία και κολλήστε την

Kağıt resmi kesin ve yapıştırın

Papírový obrázek vystřihnout a nalepit

a papírképet kivágni és felragasztani

Slika na papirju izrezati in nalepiti



Zusammenbau-Reihenfolge

Sequence of assembly

Ordre d'assemblage

Volgorde van montage

Orden de montaje

Ordine di montaggio

Ordem de montagem

Monteringsrekkefølge

Kokoamisjärjesty

Monteringsföljd

Rækkefølgen af monteringen

Последовательность монтажа

Összeszerelési sorrend

Ακολουθία συναρμολόγησης

Kurmak-Sıra

Kolejność montażu

Vrstni red sestavljanja

Montáz - postup



Biegen

Bend

Plier

Knikken

Dobiar

Piegare

Béja

Bøjede

Στροφή

Beyde

Vež

Kääntyä

Очередь

Koiei

Ότιοεί

Vízont

Obrnite

Otočenje

Ítoarce

Чары

* Nicht enthalten
Not included
Non fourni

Behoort niet tot de levering
No included
Non compresi

Não incluído
Ikke medsendt
Ingåer ej

Ikke

Benötigte Farben / Used Colors

Benötigte Farben
Required colours

Peintures nécessaires
Benodigde kleuren

Pinturas necesarias
Tintas necessárias

Colori necessari
Använda färger

Tarvittavat värit
Du trenger følgende farger

Nødvendige farger
Необходимые краски

Potrzebne kolory
Απαιτούμενα χρώματα

Gerekli renkler
Potřebné barvy

Szükséges színek
Potrebne barve

A

panzergrau, matt 78
tank grey, matt
gris blindé, mat
panzergrün, mat
plomiza, mate
cinzeno militar, fosco
color carro armato, opaco
pansargrá, matt
panssarinharmaa, himmeä
kampvogngrå, matt
pansergrå, matt
серый танк, матовый
szary czołg., matowy
γκρι ταγκς, ματ
panzer grisi, mat
panceřové šedá, matná
páncélszürke, matt
okloпно siva, mat

B

anthrazit, matt 9
anthracite grey, matt
anthracite, mat
antraciet, mat
antraçita, mate
antracite, fosco
antraçite, opaco
antracit, matt
antrasiti, himmeä
koksgrå, mat
pansergrå, matt
антрацит, матовый
antracyt, matowy
ανθρακί, ματ
antrasit, mat
antracit, matná
antracit, matt
tamno siva, mat

C

weiß, matt 5
white, matt
blanc, mat
wit, mat
blanco, mate
branco, fosco
bianco, opaco
vit, matt
valkoinen, himmeä
hvid, matt
hvit, matt
белый, матовый
biały, matowy
λευκό, ματ
beyaz, mat
biłá, matná
fehér, matt
bela, mat

D

feuerrot, glänzend 31
fiery red, gloss
rouge feu, brillant
rood helder, glansend
rojo fuego, brillante
vermelho vivo, brilhante
rosso fuoco, lucente
eldröd, blank
tulipunainen, kiiltävä
ilröd, skimmende
ilröd, blank
огненно-красный, блестящий
szerepony ognisty, błyszczący
κόκκινο φωτός, γυαλιστερό
ateş kırmızısı, parlak
ohnivě červená, lesklá
tűzpiros, fényes
ogjen rdeča, bleskajoča

E

silber, metallic 90
silver, metallic
argent, métallique
zilver, metallic
plata, metalizado
prata, metalico
argento, metallico
silver, metallic
hopea, metallikiilto
sov, metallak
sølv, metallic
серебристый, металл
srebro, metaliczny
οσημί, μεταλλικό
gümüş, metalik
stříbrná, metaliza
ezüst, metál
srebrna, metalik

F

holzbraun, seidenmatt 382
wood brown, silky-matt
brun bois, satiné mat
houtbruin, zijdemat
marrón madera, mate seda
castanho madeira, fosco sedoso
marrone legno, opaco seta
träbrun, sidenmatt
puunruskea, silkkihimmeä
träbrun, silkematt
tebrun, silkematt
древесно-коричнев., шелк.-матовый
drewnobrazowy, jedwabisto-matowy
καφέ ξύλου, μεταξοτό ματ
odun kahverengisi, ipek mat
hnědá barvy dřeva, hedvábně mat.
fabarna, selyemmatt
drevo plava, svila mat

G

beige, matt 89
beige, matt
beige, mat
beige, mate
beige, fosco
beige, opaco
beige, matt
beige, himmeä
beige, mat
beige, matt
бежовый, матовый
srebro, metaliczny
beżowy, matowy
μπεζ, ματ
bej, mat
bežová, matná
bézs, matt
bež (slonova kost), mat

H

messing, metallic 92
brass, metallic
laiton, métallique
messing, metallic
latón, metalizado
latão, metalico
otone, metallico
mässing, metallic
messinki, metallikiilto
messing, metallak
messing, metallic
латунный, металл
mosiądz, metaliczny
ορείχαλκου, μεταλλικό
píring, metalik
mosazná, metaliza
sárgaréz, metál
mesing, metalik

I

Afrikanbraun, matt 17
Africa brown, matt
Brun Afrique, mat
Afrikabruin, mat
Marrón africano, mate
Castanho-africano, mate
Bruno africano, opaco
Afrikabrun, matt
Khakimruskea, matta
Afrikabrun, mat
Afrika-brun, matt
Африкано-коричневый, матовый
Braz afrykański, matowy
Καφέ Αφρικής, ματ
Afrika kahverengisi, mat
Afrikabarna, matt
Afrička hnědá, matná
Afrískorjava, brez leska

J

Erde dunkel, matt 82
Dark earth, matt
Terre foncée, mat
Donker aardkleurig, mat
Color tierra oscuro, mate
Terra-escuro, mate
Terra scura, opaco
Jord mørk, matt
Mullanruskea, matta
Mørk jord, mat
Jord mørk, matt
Темный земляной, матовый
Ciemnoziemny, matowy
Γήινο σκούρο, ματ
Toprak koyu, mat
Földszínű, matt
Zemité tmavá, matná
Prstena temna, brez leska

K

sand, matt 16
sandy yellow, matt
couleur de sable, mat
zandkleur, mat
arena, mate
areia, fosco
sabbia, opaco
sand, matt
hiekkä, himmeä
sand, mat
sand, matt
песчаный, матовый
piaskowy, matowy
χρώμα άμμου, ματ
kum rengi, mat
písková, matná
homokszínű, matt
pesek, mat

L

eisen, metallic 91
steel, metallic
coloris fer, métallique
ijzerkleurig, metallic
ferroso, metalizado
ferro, metalico
ferro, metallico
järnfärg, metallic
teräksenvärinen, metallikiilto
jern, metallak
jern, metallic
стальной, металл
żelazo, metaliczny
σιδηρού, μεταλλικό
demir, metalik
železná, metaliza
vas, metál
železná, metalik

Beiliegenden Sicherheitstext beachten / Please note the enclosed safety advice

D: Beiliegenden Sicherheitstext beachten und nachschlagbereit halten.

GB: Please note the enclosed safety advice and keep safe for later reference.

F: Respecter les consignes de sécurité ci-jointes et les conserver à portée de main.

NL: Houdt u aan de bijgaande veiligheidsinstructies en hou deze steeds bij de hand.

E: Observar y siempre tener a disposición este texto de seguridad adjunto.

I: Seguire le avvertenze di sicurezza allegate e tenerle a portata di mano.

P: Ter em atenção o texto de segurança anexo e guardá-lo para consulta.

S: Beakta bifogad säkerhetstext och håll den i beredskap.

FIN: Huomioi ja säilytä oheiset varoitukset.

DK: Overhold vedlagte sikkerhedsanvisninger og hav dem liggende i nærheden.

N: Ha alltid vedlagt sikkerhetstekst klar til bruk.

RUS: Соблюдать прилагаемый текст по технике безопасности, хранить его в легко доступном месте.

PL: Stosować się do załączonej karty bezpieczeństwa i mieć ją stale do wglądu.

GR: Προσέξτε τις συνημμένες υποδείξεις ασφαλείας και φυλάξτε τις έτσι ώστε να τις έχετε πάντα σε διάθεσή σας.

TR: Ekteki güvenli talimatlarını dikkate alıp, bakabileceğiniz bir şekilde muafaza ediniz.

CZ: Dbejte na přiložený bezpečnostní text a mějte jej připravený na dosah.

H: A mellékelt biztonsági szöveget vegye figyelembe és tartsa fellepozásra készen!

SLO: Priložena varnostna navodila izvajajte in jih hranite na vsem dostopnem mestu.

Dieser Bausatz wurde in mehrfachen Qualitäts- und Gewichtskontrollen auf Vollständigkeit überprüft. Reklamationen können nur bearbeitet werden, wenn die **Bauanleitung**, das aus der Kartonage herausgeschnittene **EAN-Strichcode-Feld** und der **Kassenbon** eingeschickt werden. Bitte haben Sie Verständnis dafür, dass wir nur Gewährleistung bei aktuellen Artikeln übernehmen können, die im Zeitraum der letzten 24 Monate erworben worden sind. **Adressen ändern** Reklamationen werden von uns nicht angenommen!
Einzelteile für Umbauten können gegen Vorkasse erworben werden*. Unsere Adresse: Revell GmbH & Co. KG, Abteilung X, Henschelstr. 20-30, 32257 Bünde. Dieser Direktservice gilt für die Länder: Deutschland, Benelux, Österreich, Frankreich, Großbritannien. Reklamationen aus den übrigen Ländern werden über die jeweiligen Distributeure abgewickelt. Bitte kontaktieren Sie Ihren Händler.

This Model Kit has been subject to extensive quality and weight checks during the manufacturing process to ensure it leaves our warehouse in perfect condition. We are only able to process applications for missing parts if the following procedure is followed. In all cases the following will be required before we are able to process any request: Original receipt (proof of purchase) original instruction sheets (will be returned) and the bar code cut out of the box. We may not be able to process requests for products that have been discontinued for more than 24 months. Products that are returned directly to us without prior authorisation by a company representative will not be accepted and returned to sender. Replacement parts for conversion or spares will continue to be available however they will incur a handling charge. Please write to: Department X Revell GmbH & Co. KG, Henschelstr 20-30, 32257 Bünde.

This direct service is only available in the following markets: Germany, Benelux, Austria, France & Great Britain, Revell GmbH & Co. KG, Orchard Mews, 18c High Street, Tring, Herts. HP23 5AH, Great Britain.
For all other markets please contact your local dealer or distributor directly.

Afin de vous donner entière satisfaction et pour nous assurer que tous les éléments nécessaires au montage de votre maquette sont présents dans la boîte, cet article a subi dans son intégralité divers contrôles qualitatifs ainsi que des contrôles de poids.

Si toutefois vous deviez nous faire part de certaines réclamations, nous vous prions de bien vouloir vous adresser à votre revendeur habituel, muni de la notice de montage, du code EAN découpé sur la boîte, ainsi que de votre ticket de caisse.

Le SAV ne sera assuré que pour les articles ayant été acquis depuis moins de 24 mois. Les pièces de rechange utilisées pour la transformation de maquettes pourront être obtenues en pré-paiement. Dans le cas où vous n'obtiendriez pas satisfaction, vous pouvez vous adresser directement à notre service SAV à l'adresse suivante: REVELL GmbH & Co. KG, Abteilung X, Henschelstraße 20-30, D-32257 Bünde cw Revell GmbH & Co. KG, 14 B, rue du Chapeau Rouge, F-21000 Dijon, France.

Pour tous les autres marchés, merci de prendre contact avec votre détaillant ou distributeur.

Deze bouwdoos werd verscheidene malen volledig gecontroleerd op kwaliteit en gewicht. Klachten kunnen slechts in behandeling worden genomen indien de bouwhandleiding, de uit de doos geknipte EAN - streepjescode en de kassabon zijn meegezonden. Wij vragen om uw begrip dat wij alleen garantie kunnen geven voor huidige artikelen die binnen een periode van de laatste 24 maanden zijn gekocht. Onvolledig ingezonden klachten kunnen niet in behandeling worden genomen. Onderdelen voor ombouw kunnen tegen vooruitbetaling gekocht worden.

Ons adres is: Revell GmbH & Co. KG, Afdeling X, Henschelstrasse 20-30, 32257 Bünde, Duitsland. Deze directe service geldt alleen voor de volgende landen: Duitsland, Benelux, Oostenrijk, Frankrijk, Groot-Brittannië.

Klachten afkomstig uit overige landen worden via de eventuele lokale vertegenwoordigers van Revell afgewikkeld. Wij verzoeken U contact op te nemen met uw winkelier.

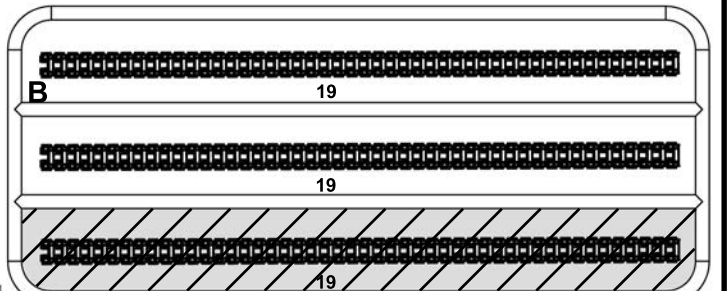
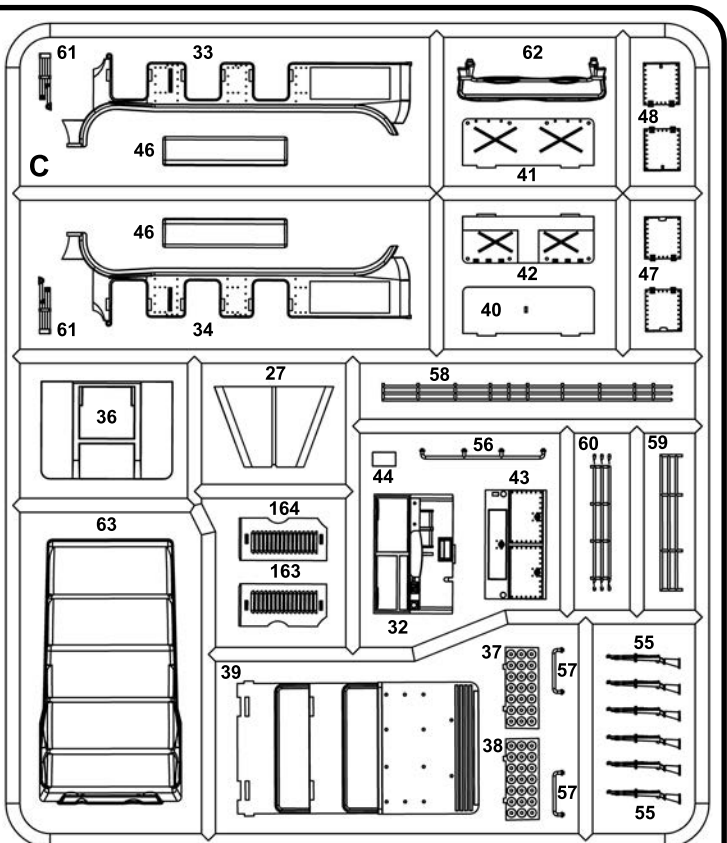
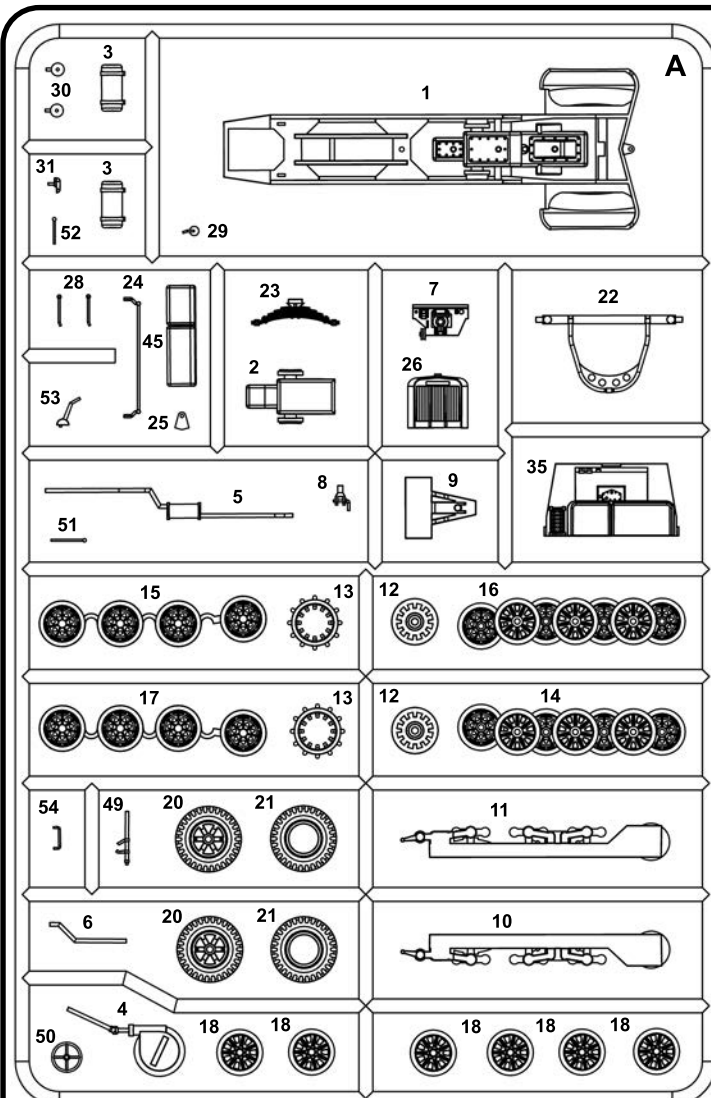

Nicht benötigte Teile
Parts not used
Pièces non utilisées
Niet benodigde onderdelen
Piezas no necesarias
Peças não utilizadas

Parti non usate
Inte använda delar
Tarpeetomat osat
Ikke nødvendige dele
Deler som ikke er nødvendige
Неиспользованные детали

Elementy niepotrzebne
μη χρειαζόμενα εξαρτήματα
Gereksiz parçalar
Nepotrebni díly
fel nem használt alkatrészek
Nepotrebni deli

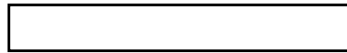

Fensterfolie
Window Sheet

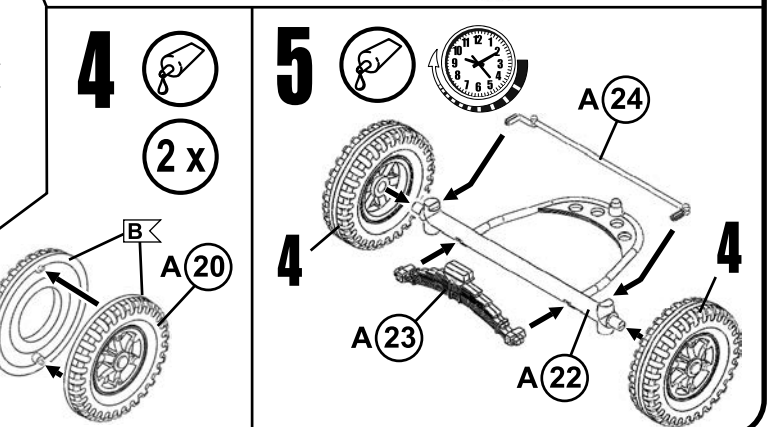
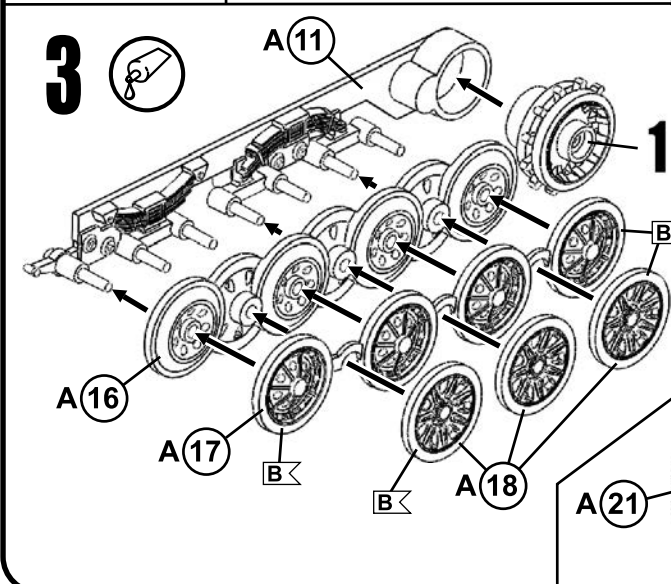
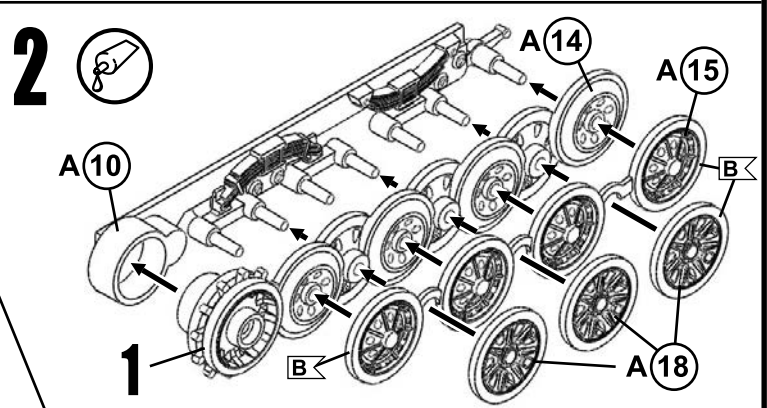
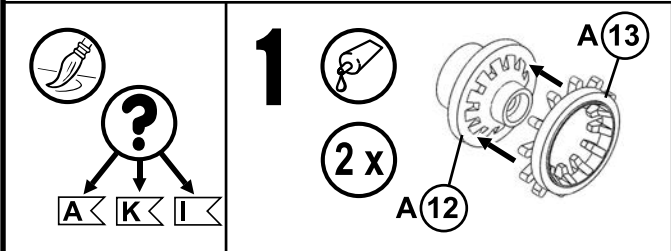

6    **2 x**

Bend with the help of hot water, do not use boiling water in any case!
Mit Hilfe von heißem Wasser biegen, auf keinen Fall kochendes Wasser verwenden!

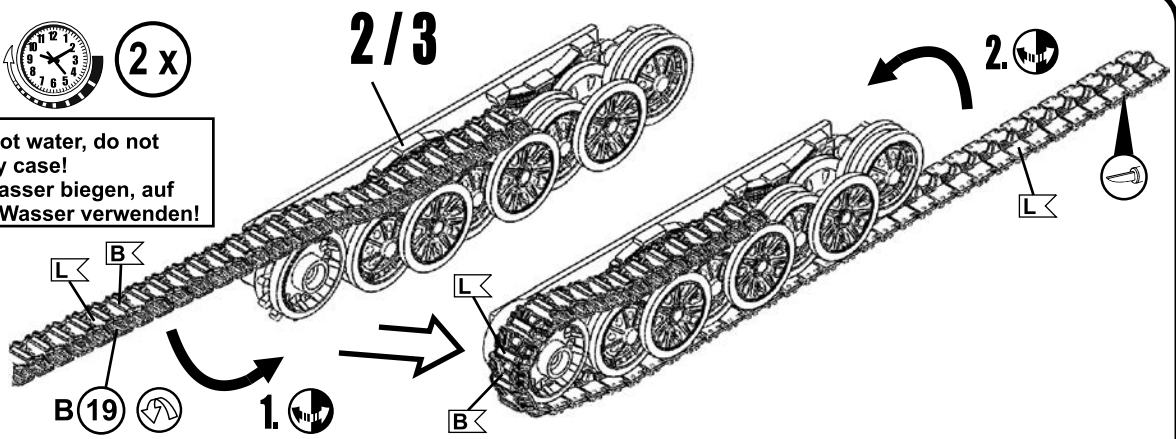
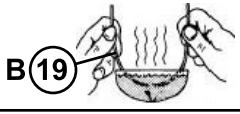

7 

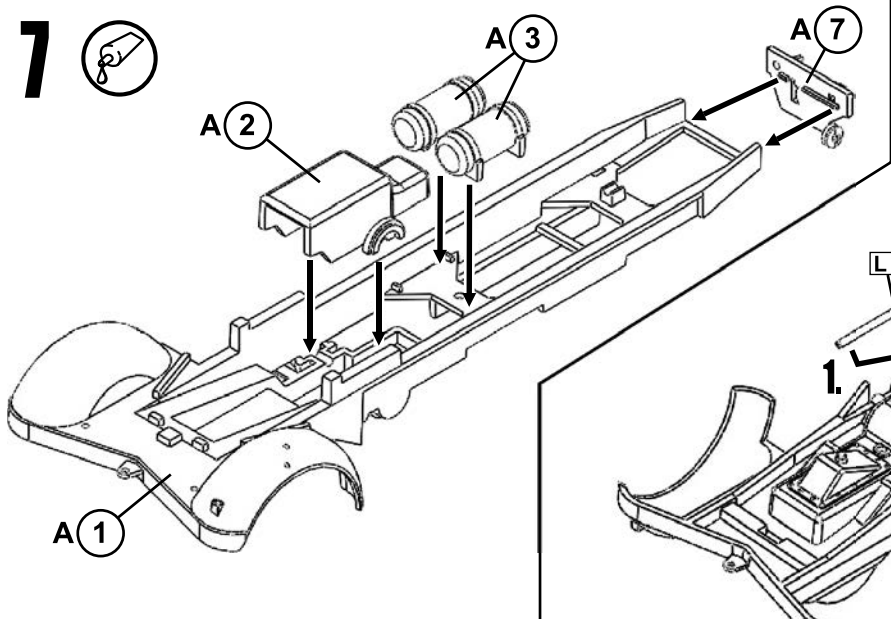

8 

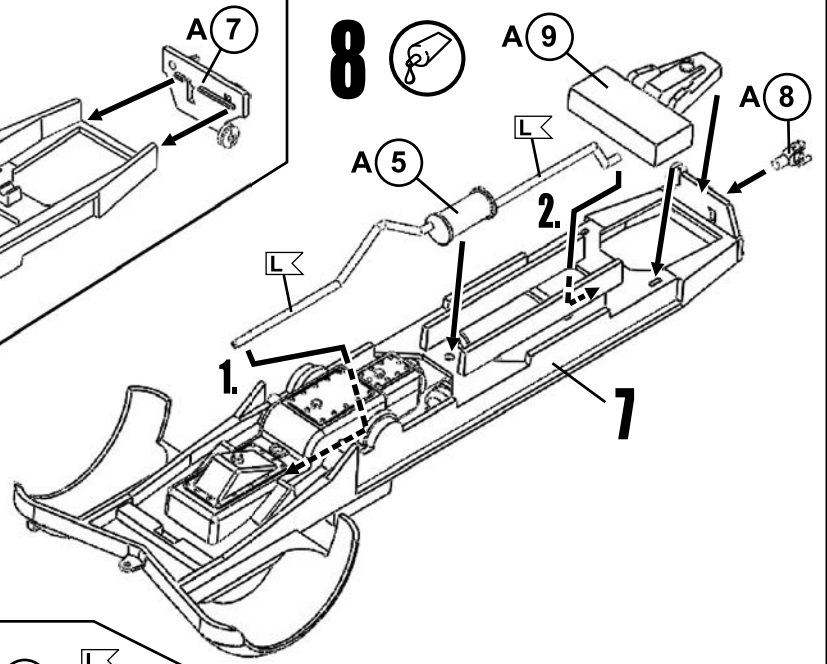

9  

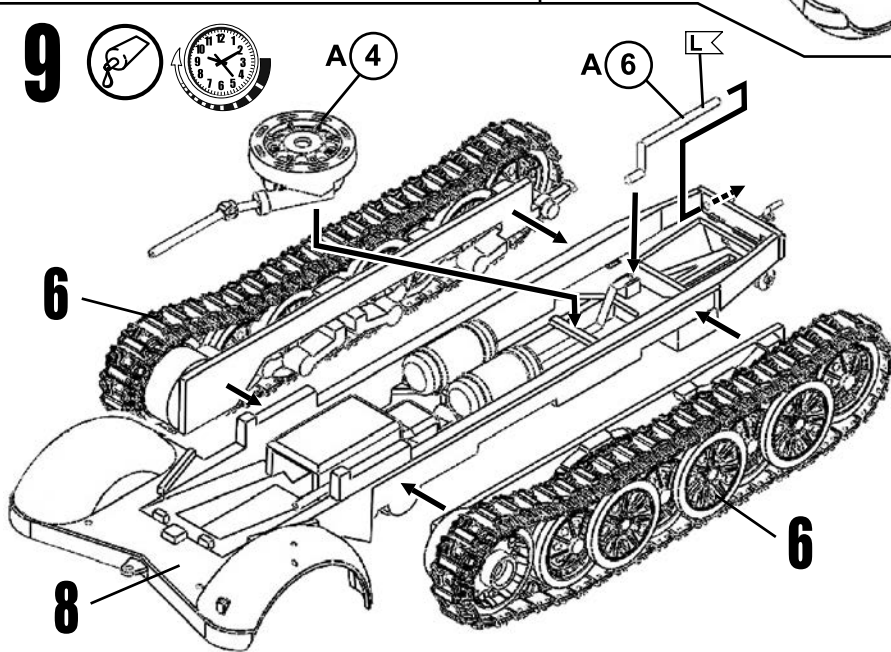

10  

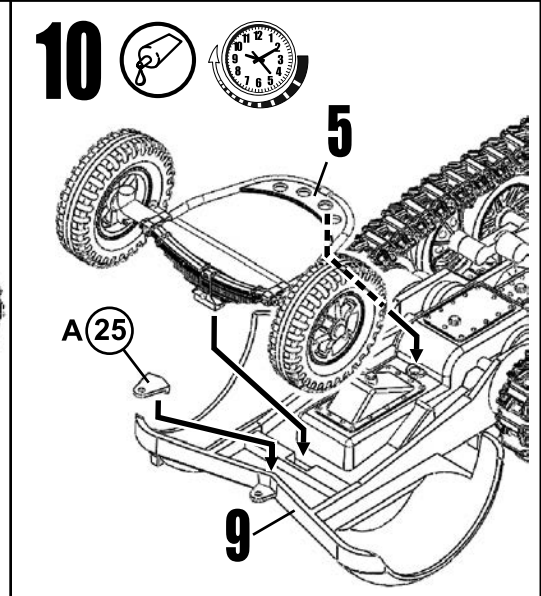

11    

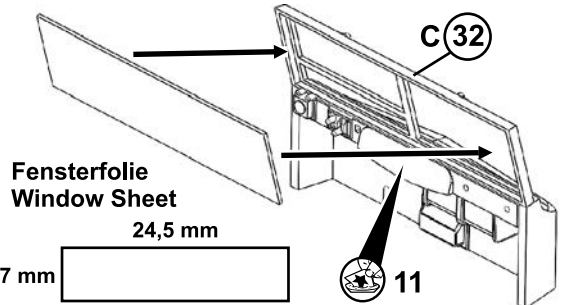

12  

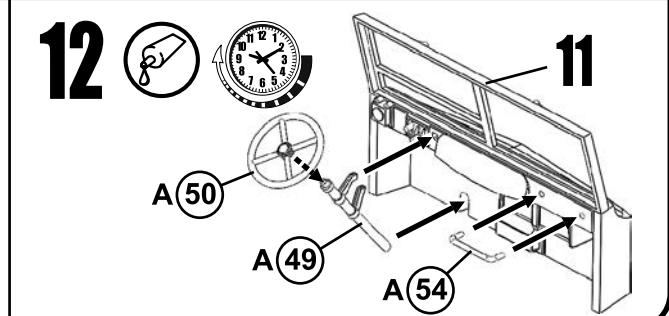

13

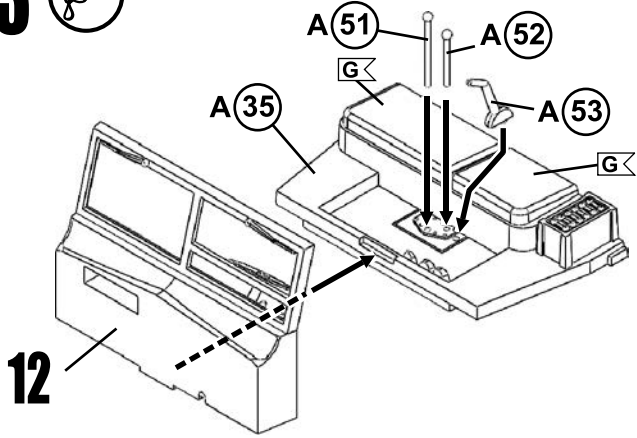

14

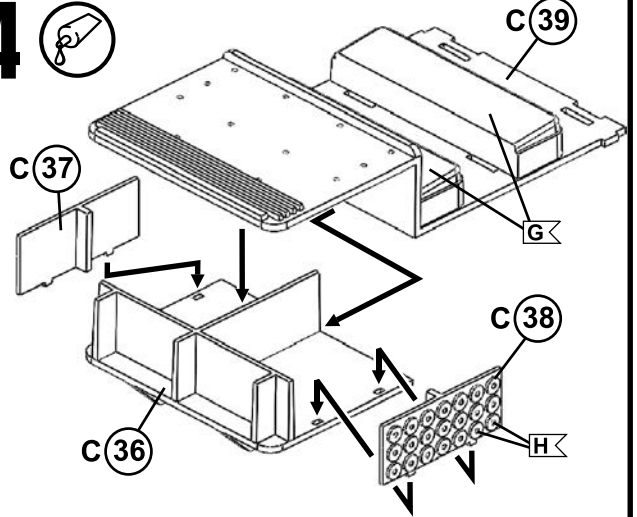

15

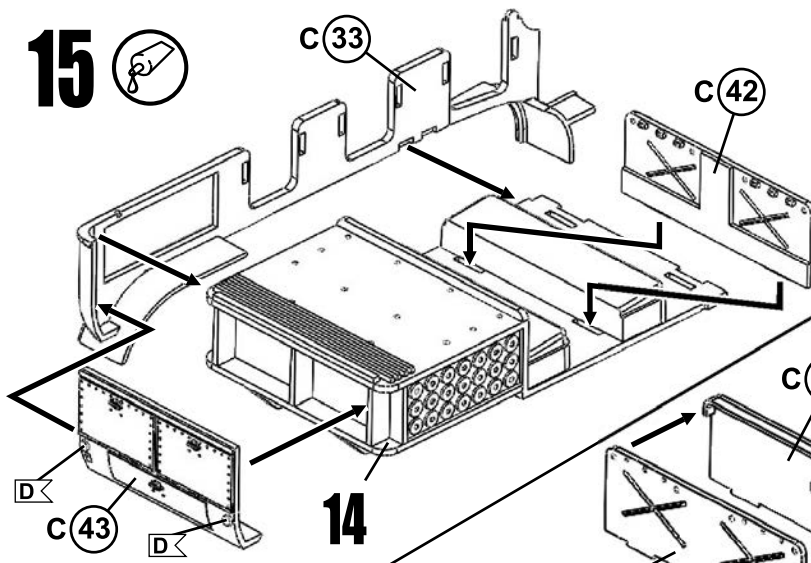

16

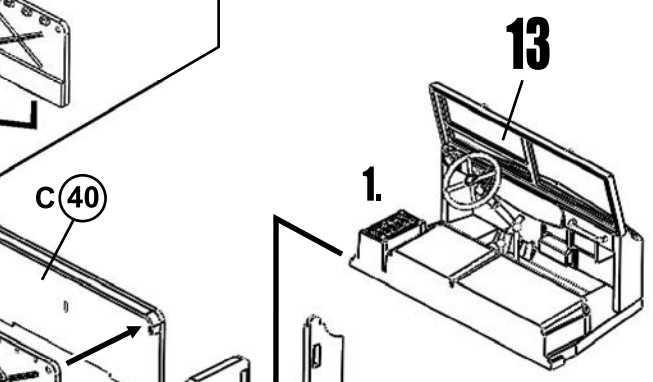

17

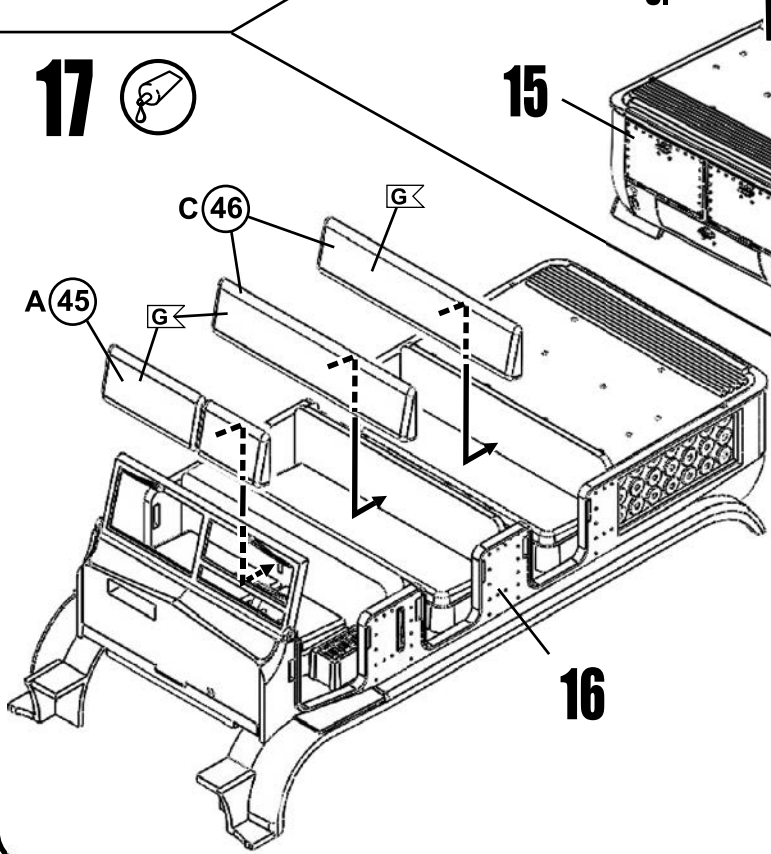

15

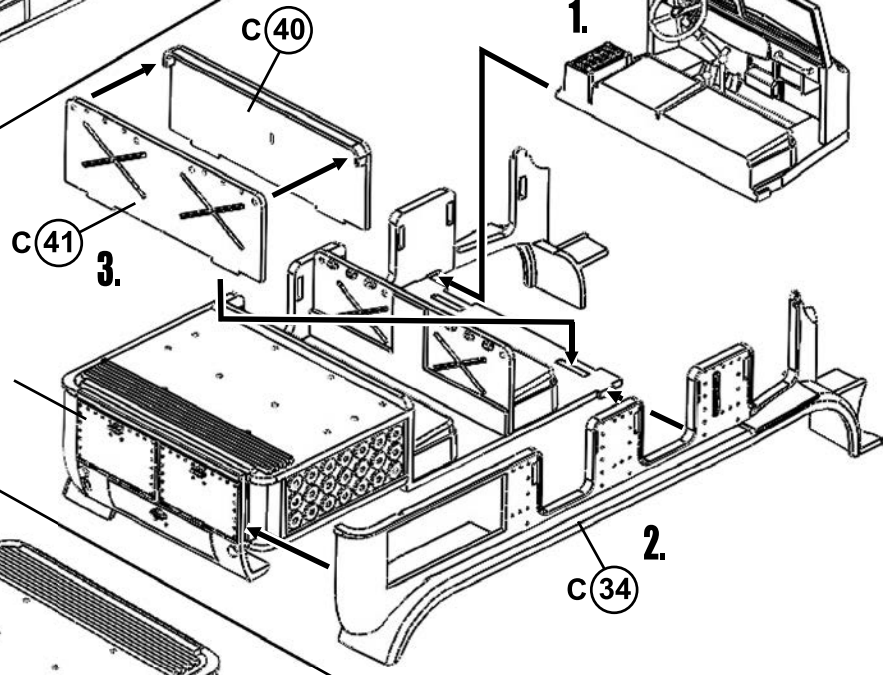

18

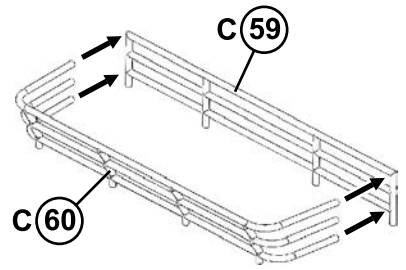

19

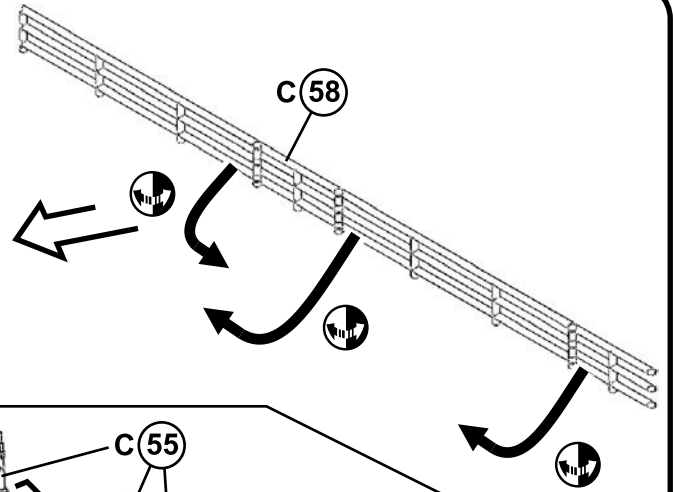
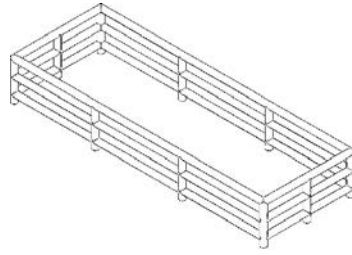

20

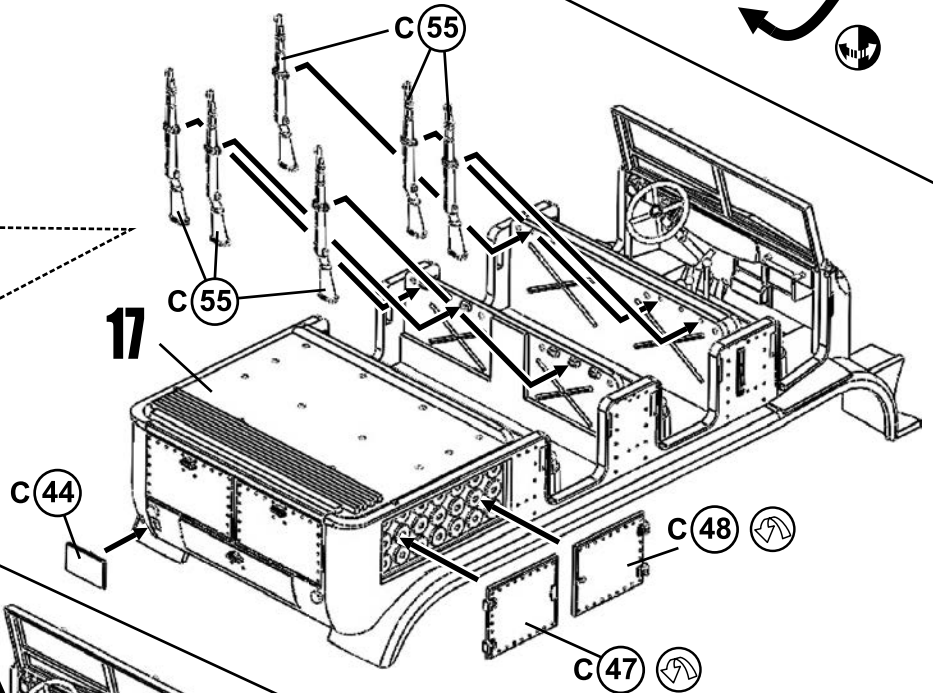
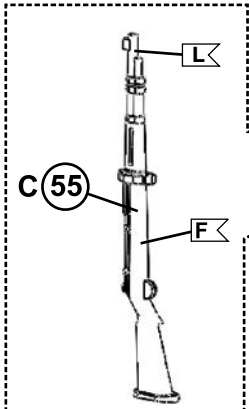

21

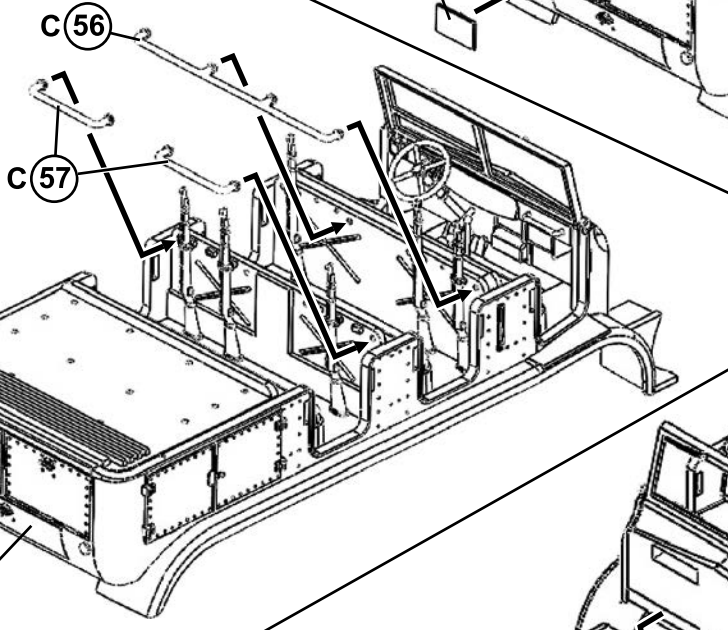

21

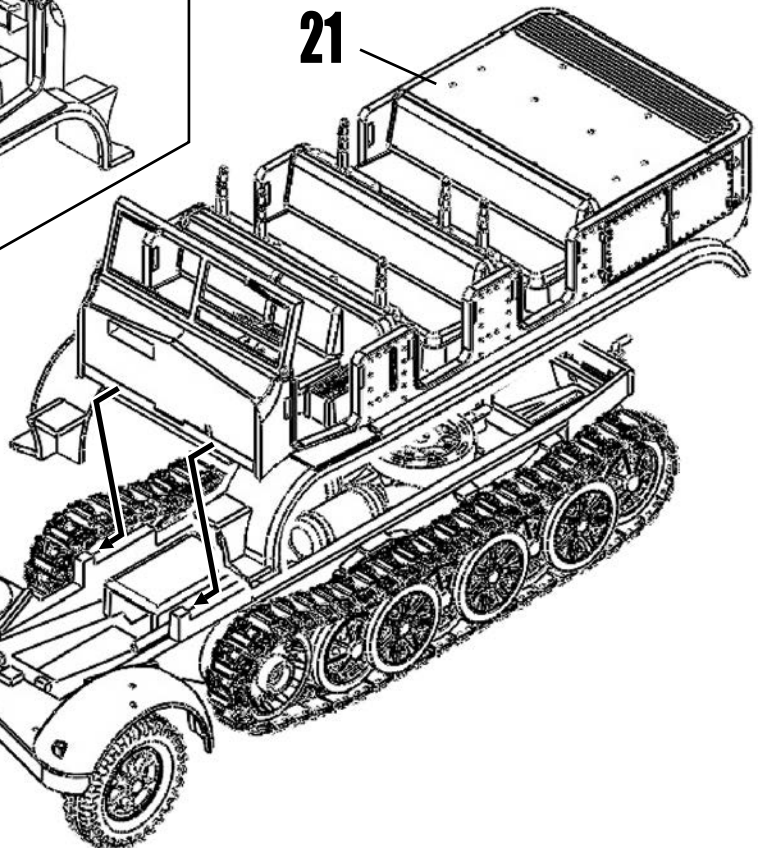

22



10

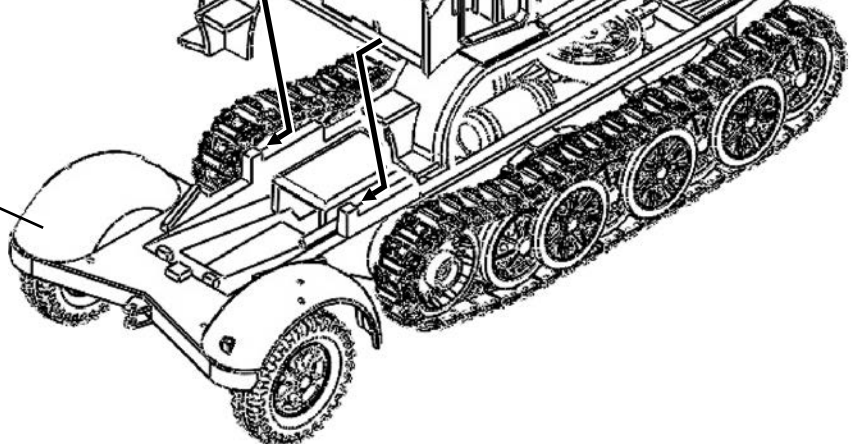

23

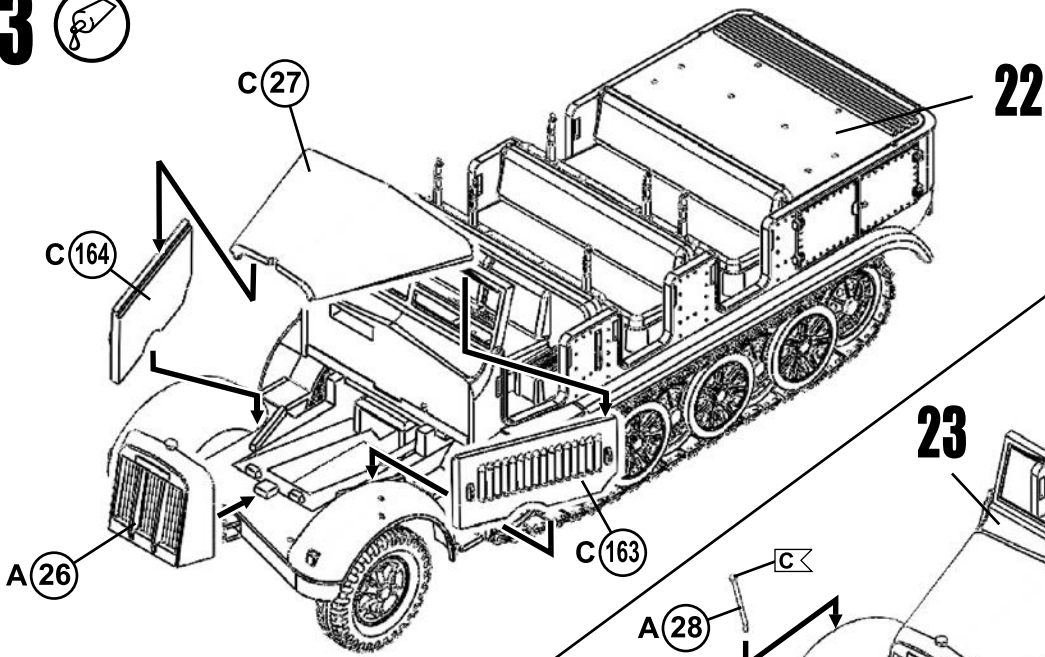

24

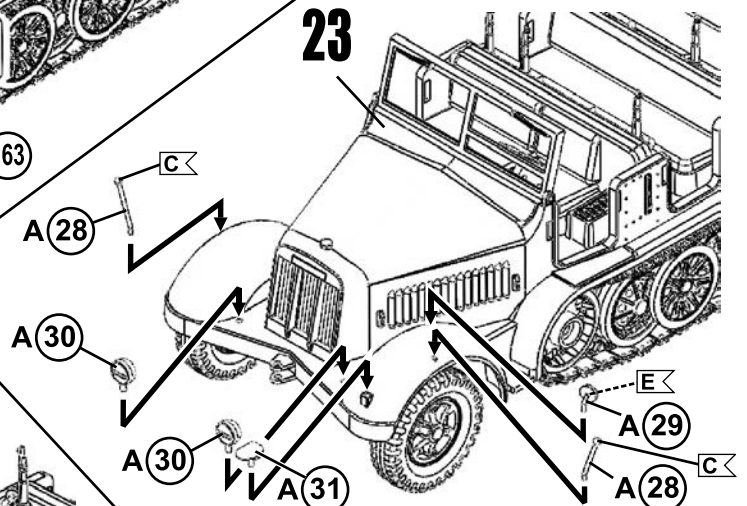

25

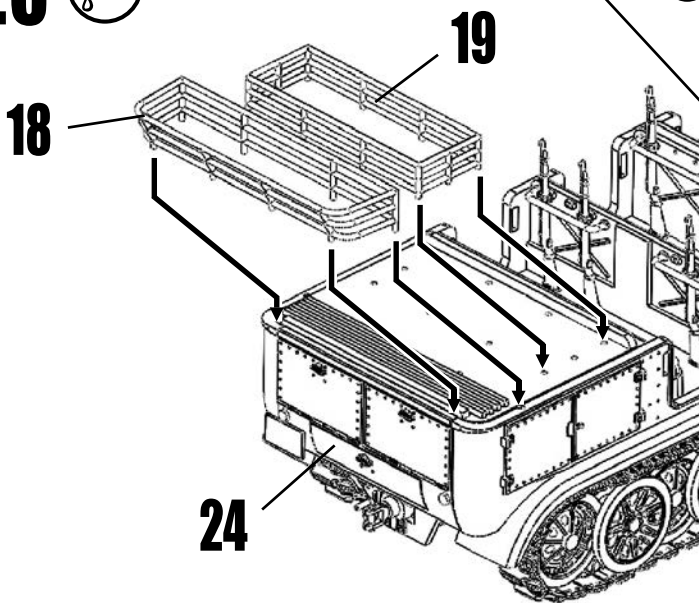

26

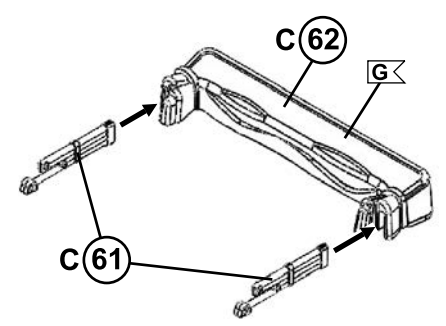

27

26

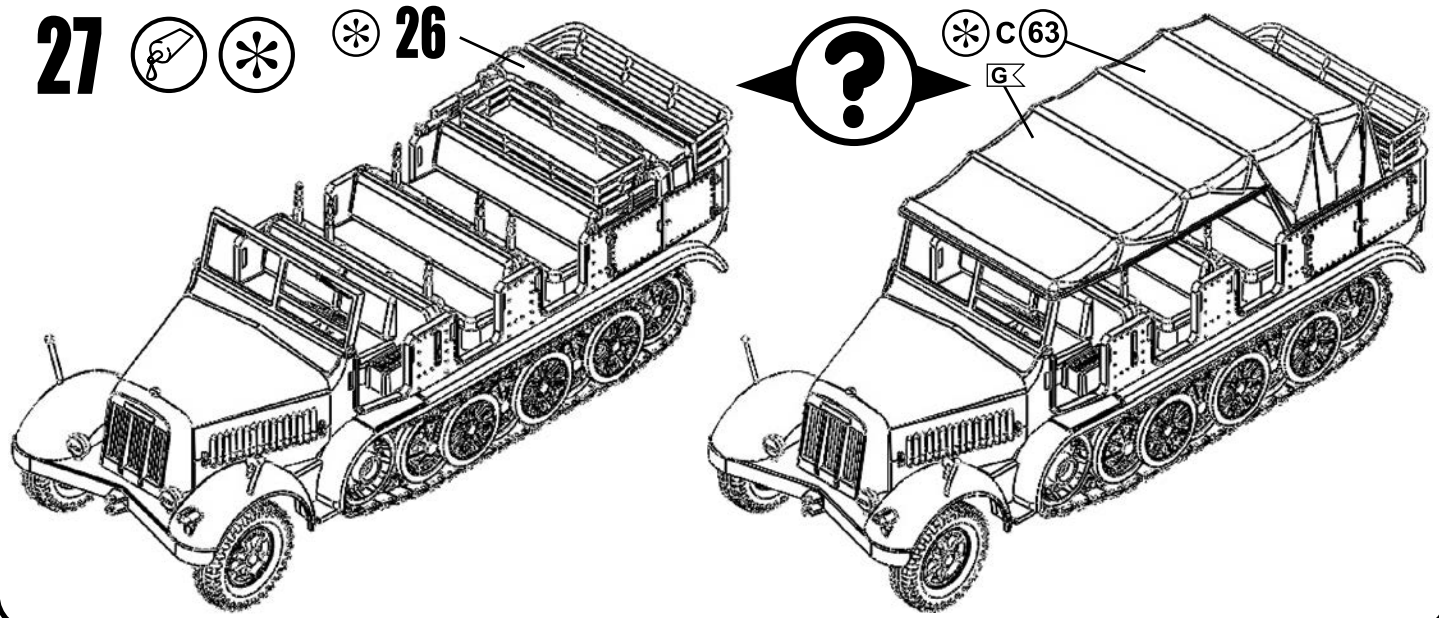

?

8,8 cm Flak 36
(03174)

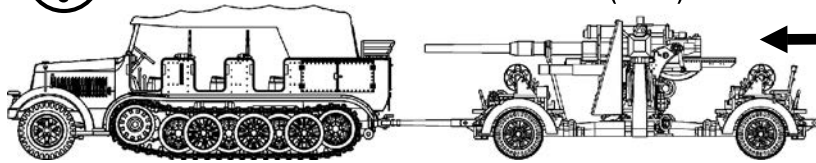

Nicht enthalten
Not included
Non fourni
Behoort niet tot de levering
No incluido
Non compresi
Não incluído
Ikke medsendt
Ingår ej

Ikke inkluderet
Eivät sisälly
Δεν συμπεριλαμβάνεται
Не содержится
Nem tartalmazza
Nie zawiera
Ni vsebovano
İçerisinde bulunmamaktadır
Není obsaženo

28 ?

**Fallschirm- Panzer- Division 1 "Hermann Göring",
Rom/ Italien, 1944**

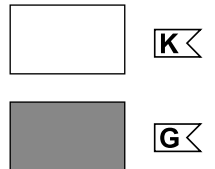
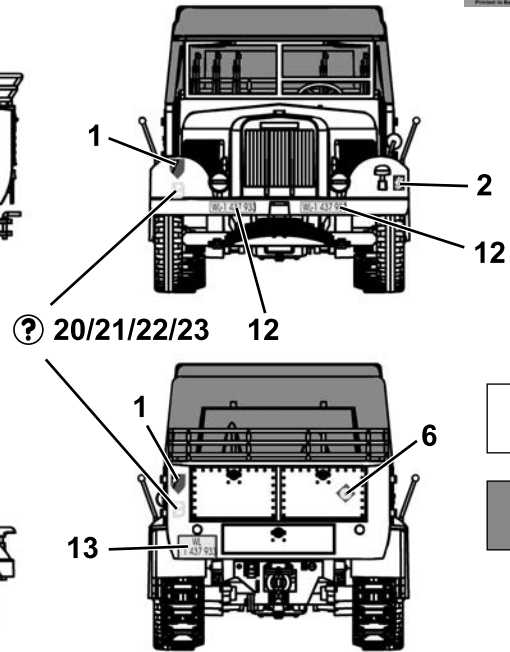
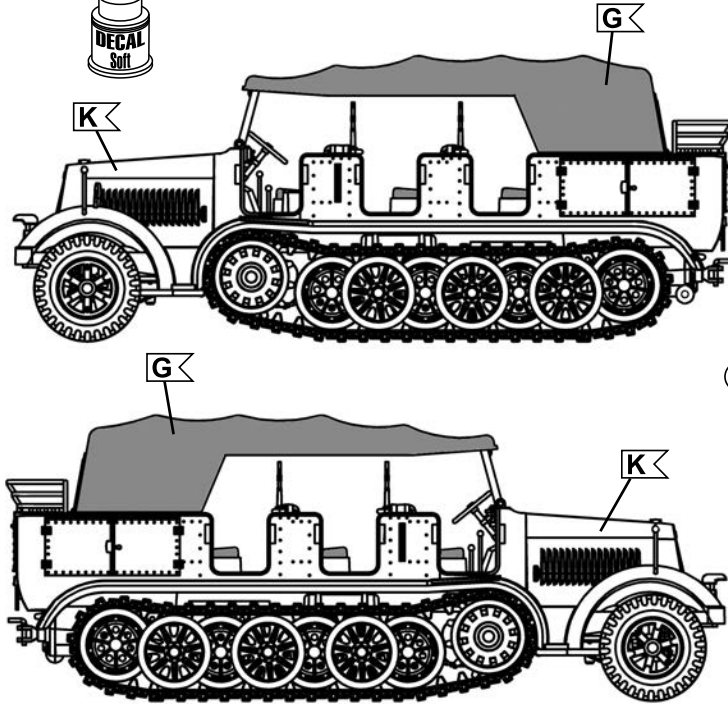

29 ?

**Regiment (motorisiert) "Hermann Göring",
Kiew/ Ukraine, 1941**

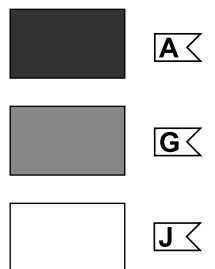
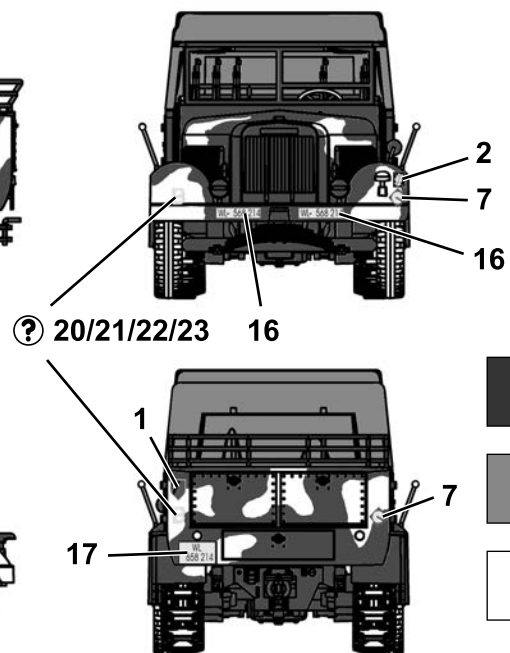
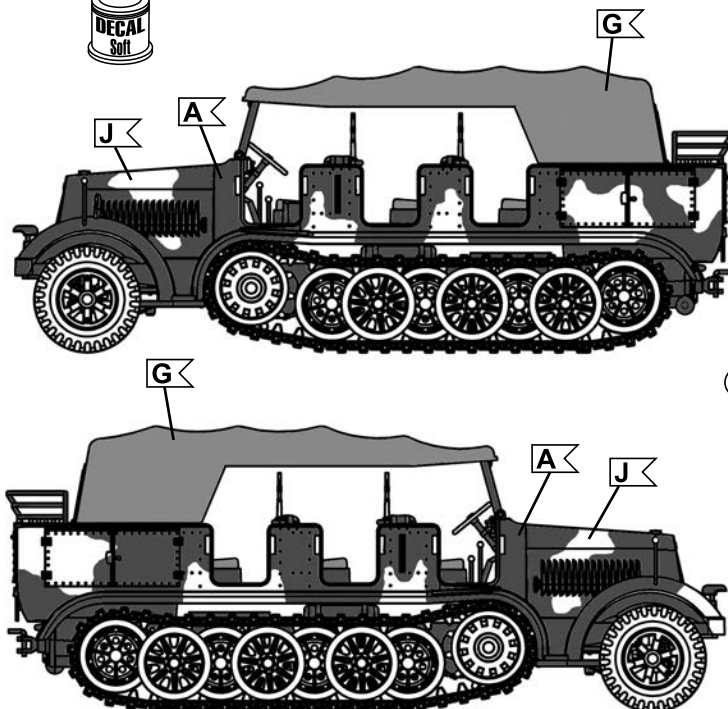

30 ? 

15. Panzer Division, Deutsches Afrika Korps, Tripolis/ Libyen, 1941

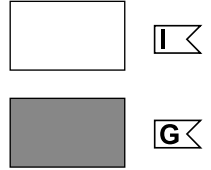
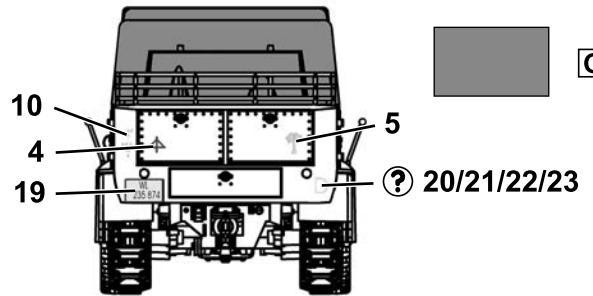
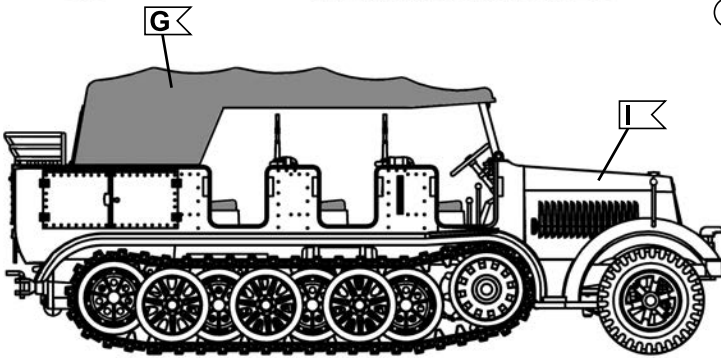
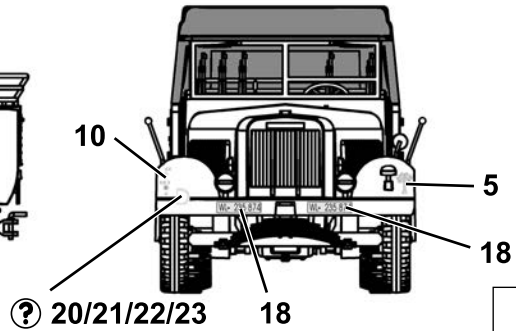
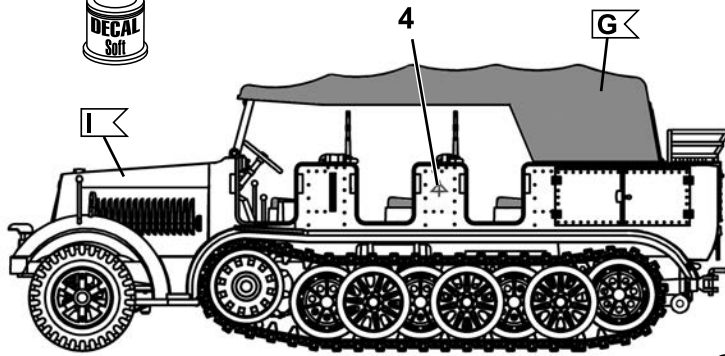

31 ? 

Heeres-Flak-Artillerie-Abteilung 277, 11. Panzer Division "Gespensterdivision", Russland, 1941

