



KIT 6523

85652300200

THE BLACK KNIGHT OF NURNBERG

The Black Knight armor represented a person of great strength and position and was developed during the late 16th Century. This piece of armor was designed to withstand a great deal of abuse while still protecting the wearer. This special suit weighed about 100 pounds while the normal suit weighed 70-85 lbs. The maneuverability of the suit was obtained by fastening together 100 pieces of steel so that the person could move in any direction. With this style of suit the knight was ready for both mounted and ground battle with the enemy. Your Monogram model features highly detailed armor pieces, an opening helmet visor to show a detailed head, removable jousting pole and display base with historical date.



* REPEAT SEVERAL TIMES
* A REPETER PLUSIEURS FOIS



* REPEAT PROCEDURE
* REPÉTEZ LE PROCÉDÉ



* OPTIONAL PARTS
* PIÈCES EN OPTION



* DECAL
* DECAL COMANIE



* ASSEMBLY CAUTION
* ATTENTION D'ASSEMBLÉE



* CEMENT TOGETHER
* A COLLER



* REMOVE AND THROW AWAY
* A RETIRER ET JETER



* DO NOT CEMENT
* NE PAS COLLER

READ THIS BEFORE YOU BEGIN

- * Study the assembly drawings.
- * Each plastic part is identified by a number.
- * In the assembly drawings, some parts will be marked by a star (★) to indicate chrome plated plastic.
- * For better paint and decal adhesion, wash the plastic parts in a mild detergent solution. Rinse and let air dry.
- * Check the fit of each piece before cementing in place.
- * Use only cement for polystyrene plastic.
- * Scrape plating and paint from areas to be cemented.
- * Allow paint to dry thoroughly before handling parts.
- * Any unused parts may be discarded.

DECAL APPLICATION INSTRUCTIONS

1. Cut desired decal from sheet.
2. Dip decal in water for a few seconds.
3. Place wet decal on paper towel.
4. Wait until decal is movable on paper backing.
5. Place decal in position on model, face up and slide backing away.
6. Press out air bubbles with a soft damp cloth.
7. Milkiness that may appear is for better decal adhesion and will dry clear. Wipe away any excess adhesive.
8. Do not touch decal until fully dry.
9. Allow the decals 48 hours to dry before applying clear coat.

NOTE: Decals are compatible with setting solutions or solvents.

LIRE CE QUI SUIT AVANT DE COMMENCER

- * Etudier les schémas de montage.
- * Chaque pièce en plastique est identifiée par un numéro.
- * Sur les schémas de montage, certaines pièces sont marquées d'une étoile (★) pour indiquer qu'elles sont en plastique chromé.
- * Pour une meilleure prise de la peinture et des autocollants, laver les pièces en plastique avec une solution détergente peu concentrée. Les rincer et les laisser sécher à l'air.
- * Vérifier que chaque pièce s'ajuste bien avant de la coller en place.
- * N'utiliser que de la colle pour polystyrène.
- * Gratter les parties à coller pour enlever le chrome et la peinture.
- * Laisser la peinture bien sécher avant de manipuler les pièces.
- * Toute pièce inutilisée peut être jetée.

DIRECTIVES D'APPLICATION DES AUTOCOLLANTS

1. Découper l'autocollant désiré de la feuille.
2. Tremper l'autocollant dans de l'eau pendant quelques secondes.
3. Placer l'autocollant mouillé sur une serviette en papier.
4. Attendez que l'autocollant puisse être déplacé sur son support en papier.
5. Mettre l'autocollant en position sur le modèle face sur le dessus et faire glisser le support pour l'enlever.
6. Appuyer avec un chiffon doux humide pour éliminer les bulles d'air.
7. La substance laiteuse qui peut apparaître est destinée à améliorer l'adhésion de l'autocollant et devient incolore au séchage. Essuyer pour enlever tout excédent d'adhésif.
8. Ne pas toucher l'autocollant tant qu'il n'est pas bien sec.
9. Laisser l'autocollant sécher pendant 48 heures avant d'appliquer une couche transparente.

REMARQUE: Les autocollants sont compatibles avec les solutions de fixation ou les solvants.

This paint guide is provided to complete this kit as shown on the box.

Ce guide de peintures est fourni pour reproduire le modèle réduit qui apparaît sur la boîte.

Gloss Black	Noir lustré
Red	Rouge
Flesh	Flesh
Brown	Brun
Silver	Argent
White	Blanc
Gold	Or
Steel	Acier

If you have any questions or comments, call our hotline at: **(800) 833-3570**
or, please write to:

Revell Inc Consumer Service Department, 1850 Howard Street Unit A, Elk Grove Village, Illinois 60007

Be sure to include the plan number (85652300200), part number, description, your return address and phone number.

Visit our website: www.revell.com

1

LEG / BASE ASSEMBLY

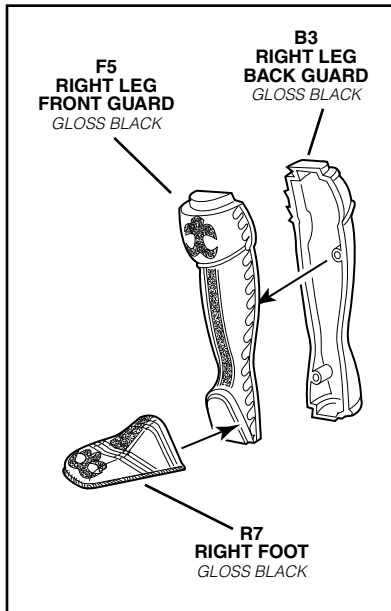

PAINT NOTE:
PARTS ARE GLOSS
BLACK WITH A
RAISED DESIGN IN
GOLD AND SILVER.
CHAIN MAIL IS
STEEL AND BELTS
ARE BROWN WITH
STEEL BUCKLES

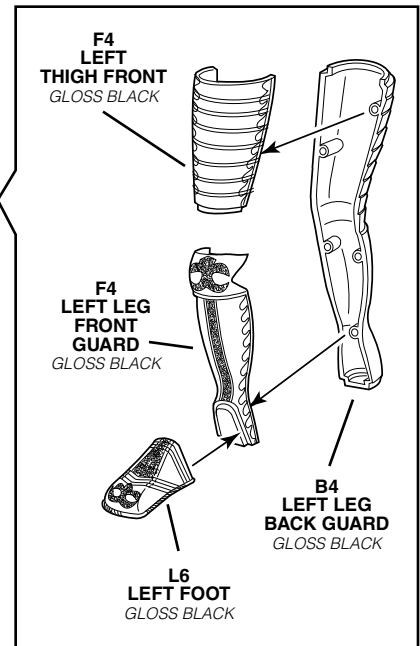
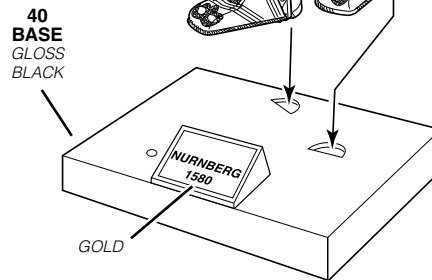

2

BODY ASSEMBLY

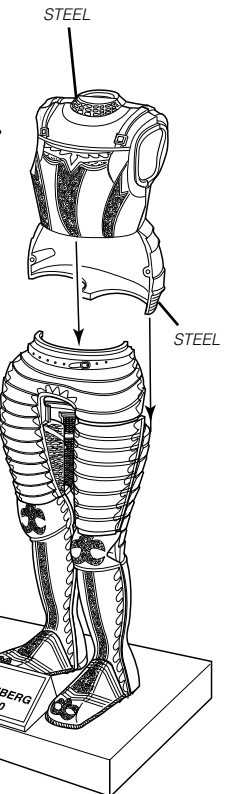
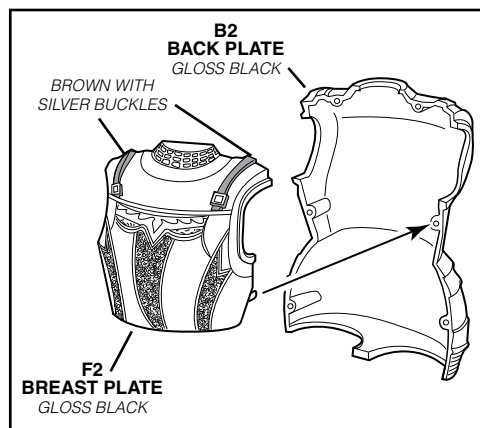
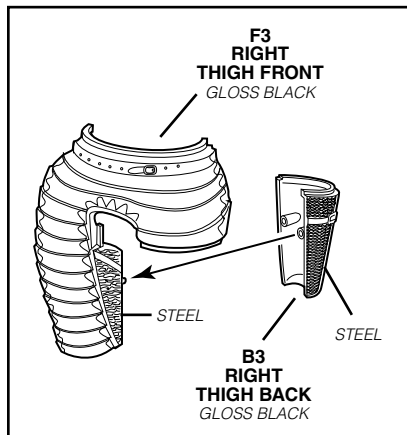

PAINT NOTE:
PARTS ARE GLOSS
BLACK WITH A
RAISED DESIGN IN
GOLD AND SILVER.
CHAIN MAIL IS
STEEL AND BELTS
ARE BROWN WITH
STEEL BUCKLES

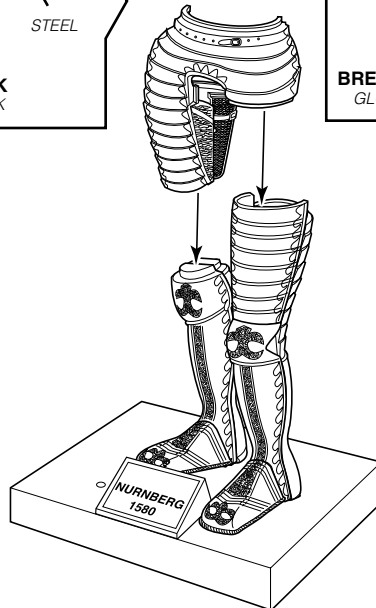

3

HEAD / HELMET ASSEMBLY

F1 FACE
B1 HEAD

PAINT NOTE:
FACE FLESH COLOR.
HAIR BROWN, EYES
BROWN, LIPS RED

R14 RIGHT HELMET HALF
GLOSS BLACK

L14 LEFT HELMET HALF
GLOSS BLACK

PAINT NOTE:
GLOSS BLACK
WITH RAISED
DESIGN IN GOLD

15 VISOR
GLOSS BLACK

16 FACE GUARD
GLOSS BLACK

**REMOVABLE HELMET
VISOR SWINGS OPEN
AND CLOSED**

4

ARM ASSEMBLY

B8 LEFT ARM INNER GUARD
GLOSS BLACK

A8 LEFT ARM OUTER GUARD
GLOSS BLACK

STEEL

B12 LEFT ELBOW INSIDE GUARD
GLOSS BLACK

A12 LEFT ELBOW OUTSIDE GUARD
GLOSS BLACK

34 BATTLE CLUB
BROWN

GLOSS BLACK

F10 LEFT GAUNTLET PALM
GLOSS BLACK

B10 LEFT GAUNTLET HAND
GLOSS BLACK

SILVER DETAILS

PAINT NOTE:
ALL GLOSS BLACK
WITH RAISED
DESIGN IN SILVER

B11 RIGHT GAUNTLET HAND
GLOSS BLACK

F11 RIGHT GAUNTLET PALM
GLOSS BLACK

A13 RIGHT ELBOW OUTSIDE GUARD
GLOSS BLACK

B13 RIGHT ELBOW INSIDE GUARD
GLOSS BLACK

A9 RIGHT ARM OUTER GUARD
GLOSS BLACK

B9 RIGHT ARM INNER GUARD
GLOSS BLACK

STEEL DETAILS

**ARMS AND
HELMET TO BODY**

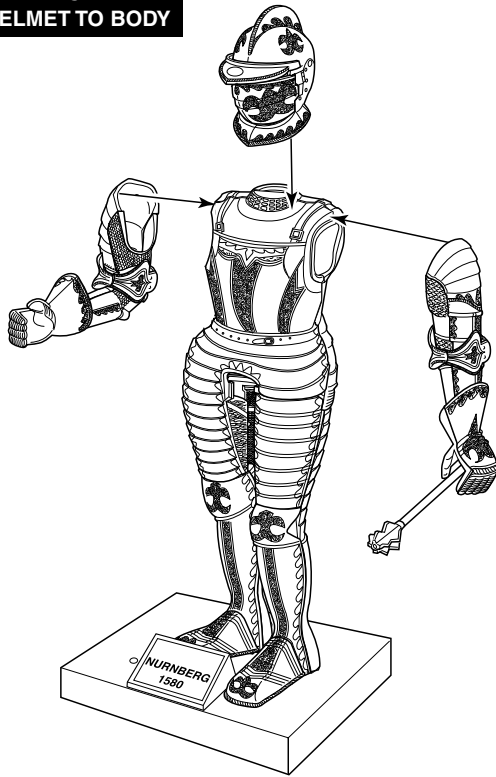

**PAINT NOTE:
ALL GLOSS BLACK
WITH RAISED
DESIGN IN GOLD
AND SILVER**

**20
RIGHT
BREAST PLATE
ORNAMENT**
GLOSS BLACK

**17
BRAYETTE**
STEEL

**19
RIGHT
KNEE
GUARD**
GLOSS BLACK

**21
LEFT
BREAST PLATE
ORNAMENT**
GLOSS BLACK

**18
LEFT
KNEE
GUARD**
GLOSS BLACK

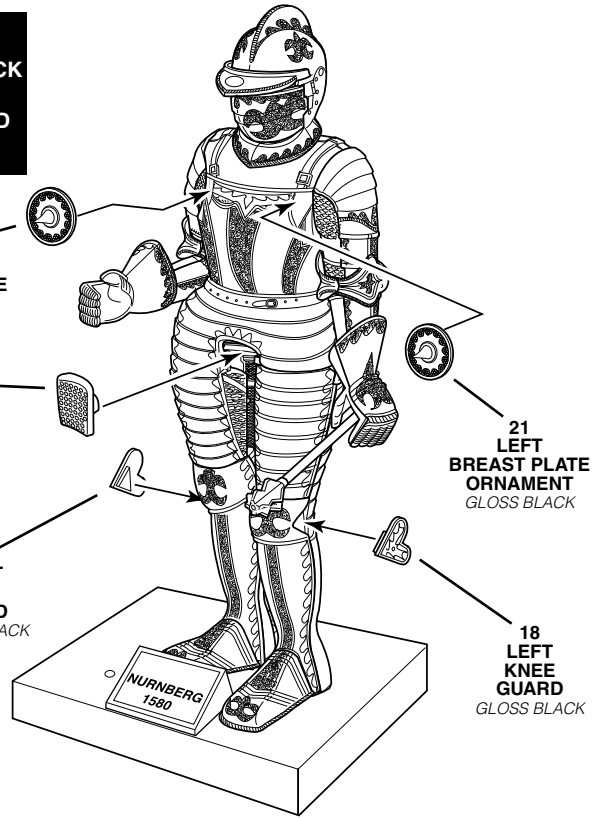

**39
LANCE**
WHITE

**22
LANCE HAND
GUARD**
GOLD

**37
LANCE HANDLE**
WHITE

