



KIT 5499

85549900200

Messerschmitt Me 262 A-1a

Jet aircraft are taken for granted today, but few people realize the first jet propelled airplane actually flew in December, 1910. It was designed by Rumanian engineer Henri Coanda and was a truly advance concept in several ways. It was powered by a 50 hp Clerget four cylinder inline engine and is what would be called a "Ducted Fan" today because the engine drove a shrouded fan, producing 485 lbs of thrust. It only flew once, when Coanda was making a high-speed taxi test, but it reached takeoff speed rapidly, surprising Coanda, who wasn't a pilot, and lost control as it lifted into the air. The little jet impacted the ground and was destroyed by fire.

In the 1930s, the Italians experimented with the pseudo-jet ducted fans, but the first true turbojet engine was proposed in Great Britain by Frank Whittle. Unfortunately, the industry looked on the concept as impractical. Whittle patented the idea in 1930, and no further work was done. But, in Germany, the prospect of a jet engine aroused great interest and in 1936 the development of the new power plant was undertaken.

On August 27, 1939, the Germans secretly flew the first turbojet airplane. So, it was a surprise when the Allies were confronted by the incredible Messerschmitt Me 262 twin jet fighter.

Today, the Me 262 is considered historically as important as the Wright Flyer in the development of aviation. It is indeed fortunate for the world that the significance of the Me 262 was not recognized by Hitler, and the plane was never used to it's full capabilities. But it was a remarkable weapon and did prove effective in the limited role in which it was used.

This kit contains markings for two Me 262A-1a fighters. One of these planes was flown by Oberfeldwebel Heinz Arnold, and is believed to be the only Me 262 to display combat victories. On April 16, 1945, Arnold went missing on a transfer flight in another plane, his plane being out of commission on that day. Arnold's Me 262 was ultimately acquired by the Allies and was refurbished for display in the Smithsonian's Air and Space Museum.

READ THIS BEFORE YOU BEGIN

- * Study the assembly drawings.
- * Each plastic part is identified by a number.
- * In the assembly drawings, some parts will be marked by a star (★) to indicate chrome plated plastic.
- * For better paint and decal adhesion, wash the plastic parts in a mild detergent solution. Rinse and let air dry.
- * Check the fit of each piece before cementing in place.
- * Use only cement for polystyrene plastic.
- * Scrape plating and paint from areas to be cemented.
- * Allow paint to dry thoroughly before handling parts.
- * Any unused parts may be discarded.

DECAL APPLICATION INSTRUCTIONS

1. Cut desired decal from sheet.
2. Dip decal in water for a few seconds.
3. Place wet decal on paper towel.
4. Wait until decal is movable on paper backing.
5. Place decal in position on model, face up and slide backing away.
6. Press out air bubbles with a soft damp cloth.
7. Milkiness that may appear is for better decal adhesion and will dry clear. Wipe away any excess adhesive.
8. Do not touch decal until fully dry.
9. Allow the decals 48 hours to dry before applying clear coat.

NOTE: Decals are compatible with setting solutions or solvents.

LIRE CE QUI SUIT AVANT DE COMMENCER

- * Etudier les schémas de montage.
- * Chaque pièce en plastique est identifiée par un numéro.
- * Sur les schémas de montage, certaines pièces sont marquées d'une étoile (★) pour indiquer qu'elles sont en plastique chromé.
- * Pour une meilleure prise de la peinture et des autocollants, laver les pièces en plastique avec une solution détergente peu concentrée. Les rincer et les laisser sécher à l'air.
- * Vérifier que chaque pièce s'ajuste bien avant de la coller en place.
- * N'utiliser que de la colle pour polystyrène.
- * Gratier les parties à coller pour enlever le chrome et la peinture.
- * Laisser la peinture bien sécher avant de manipuler les pièces.
- * Toute pièce inutilisée peut être jetée.

DIRECTIVES D'APPLICATION DES AUTOCOLLANTS

1. Découper l'autocollant désiré de la feuille.
2. Tremper l'autocollant dans de l'eau pendant quelques secondes.
3. Placer l'autocollant mouillé sur une serviette en papier.
4. Attendez que l'autocollant puisse être déplacé sur son support en papier.
5. Mettre l'autocollant en position sur le modèle face sur le dessus et faire glisser le support pour l'enlever.
6. Appuyer avec un chiffon doux humide pour éliminer les bulles d'air.
7. La substance laiteuse qui peut apparaître est destinée à améliorer l'adhésion de l'autocollant et devient incolore au séchage. Essuyer pour enlever tout excédent d'adhésif.
8. Ne pas toucher l'autocollant tant qu'il n'est pas bien sec.
9. Laisser l'autocollant sécher pendant 48 heures avant d'appliquer une couche transparente.

REMARQUE: Les autocollants sont compatibles avec les solutions de fixation ou les solvants.

This paint guide is provided to complete this kit as shown on the box.

Ce guide de peinture est fourni pour reproduire le modèle réduit qui apparaît sur la boîte.

FLAT BLACK	<i>NOIR TERNE</i>
LIGHT BROWN	<i>MARRON CLAIR</i>
DARK GRAY	<i>GRIS FONCE</i>
LIGHT GRAY	<i>GRIS CLAIR</i>
ALUMINUM	<i>ALUMINIUM</i>
STEEL	<i>ACIER</i>
DARK GREEN	<i>VERT FONCE</i>
OLIVE GREEN	<i>VERT LOIVE</i>
WHITE	<i>BLANC</i>
LIGHT BLUE	<i>BLUE CLAIR</i>

If you have any questions or comments, call our hotline at: (800) 833-3570 or, please write to:

Revell-Monogram Consumer Service Department, 725 Landwehr Road, Northbrook, Illinois 60062

Be sure to include the plan number (85549900200), part number, description, your return address and phone number.

Visit our website: www.revell.com

1

COCKPIT ASSEMBLY

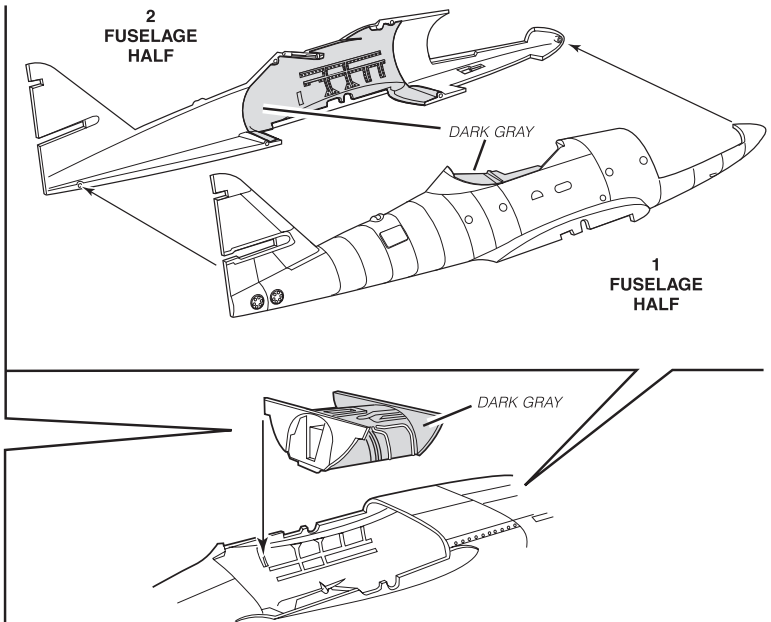
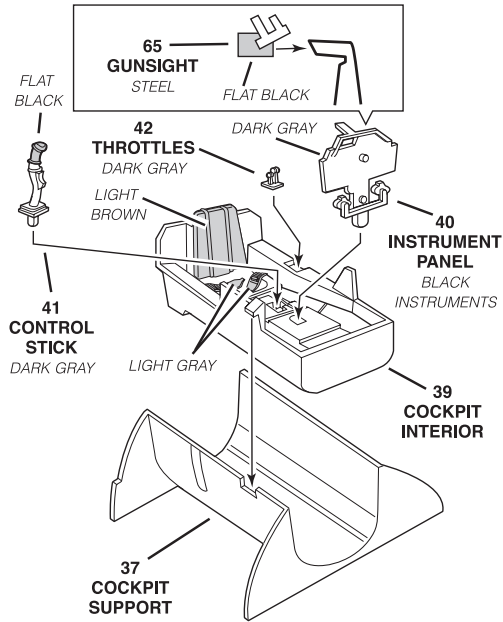

2

FRONT LANDING GEAR ASSEMBLY

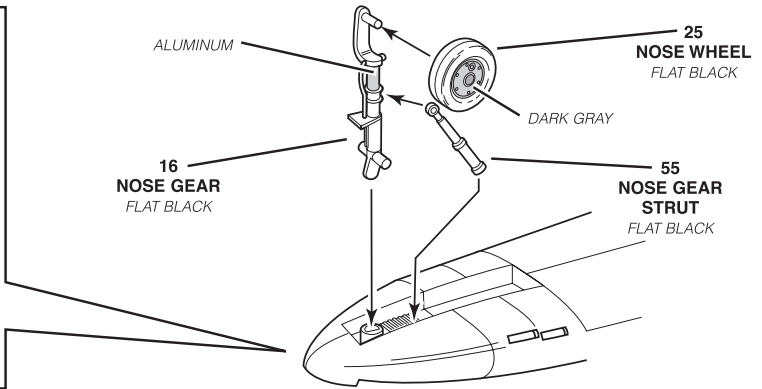
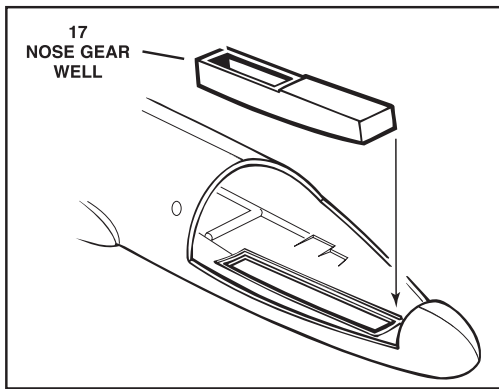

3

FRONT CANNON ASSEMBLY

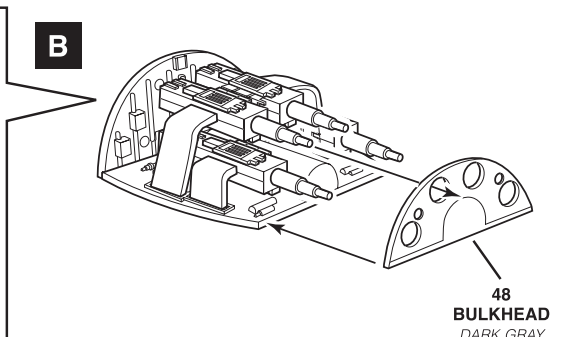
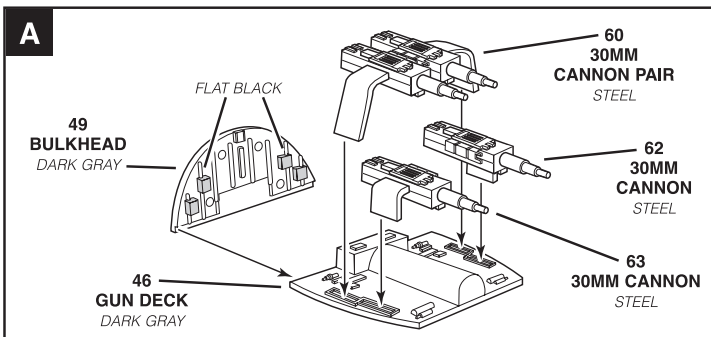

3

FRONT CANNON ASSEMBLY CONTINUED

C

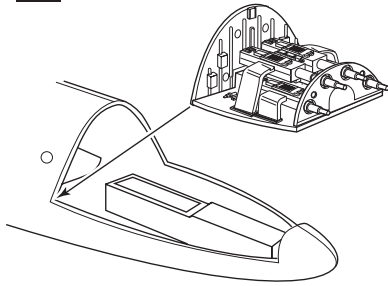

D

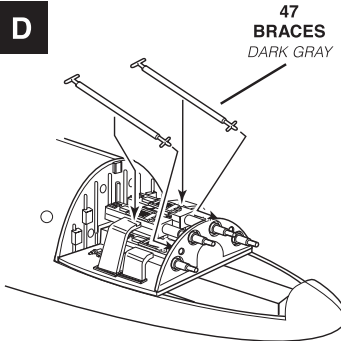

E

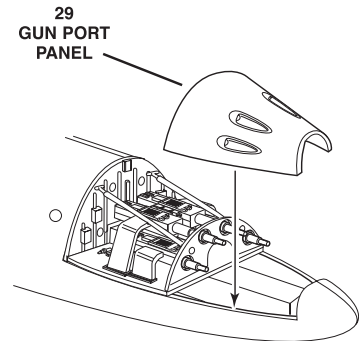

4

CANNON PANEL ASSEMBLY

?

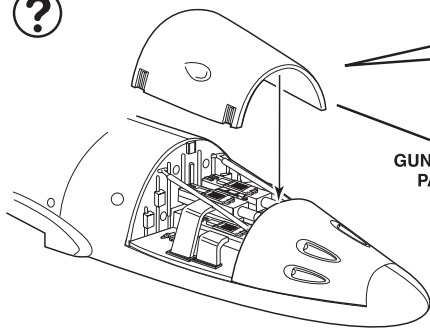

38
GUN ACCESS
PANELS

?



CUT DOORS AND CEMENT
INTO OPEN POSITION

DOOR ANGLE

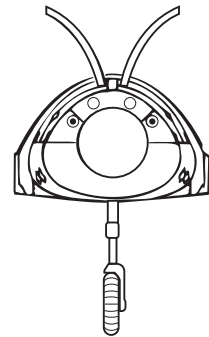

5

WING ASSEMBLY

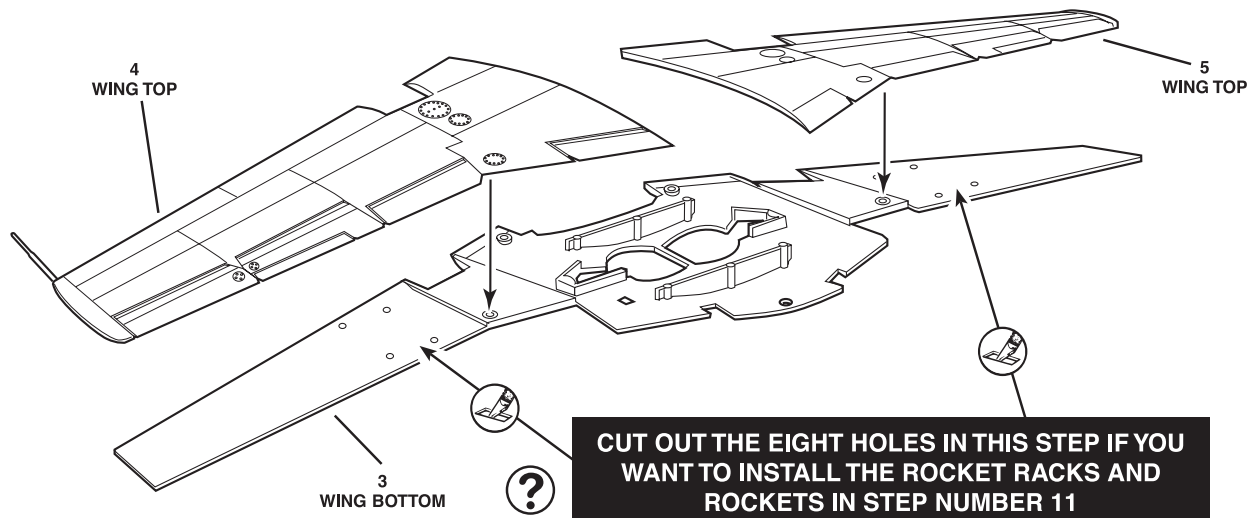

4
WING TOP

5
WING TOP

3
WING BOTTOM

CUT OUT THE EIGHT HOLES IN THIS STEP IF YOU
WANT TO INSTALL THE ROCKET RACKS AND
ROCKETS IN STEP NUMBER 11

6

ENGINE ASSEMBLY

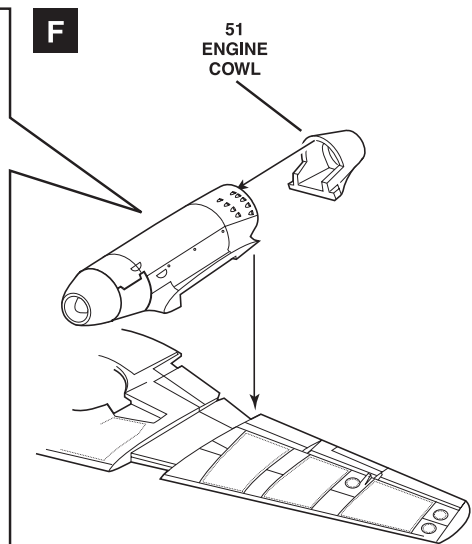
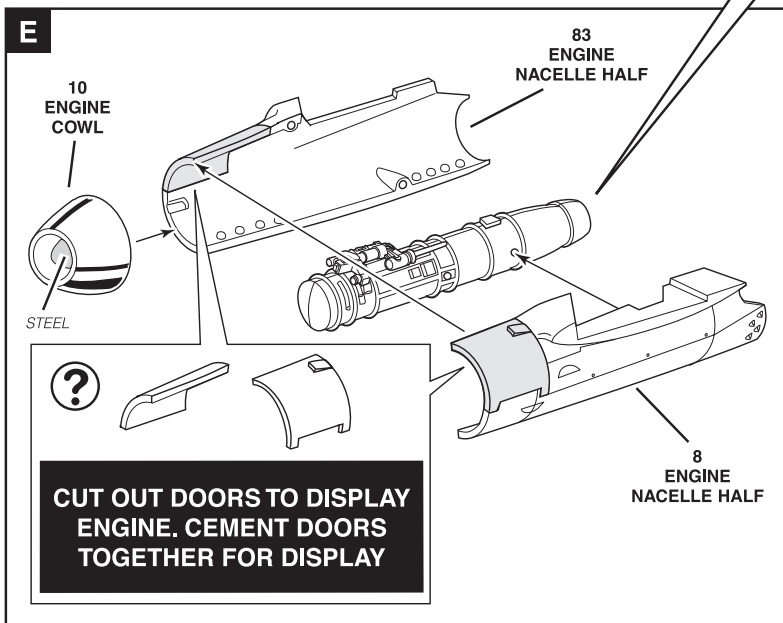
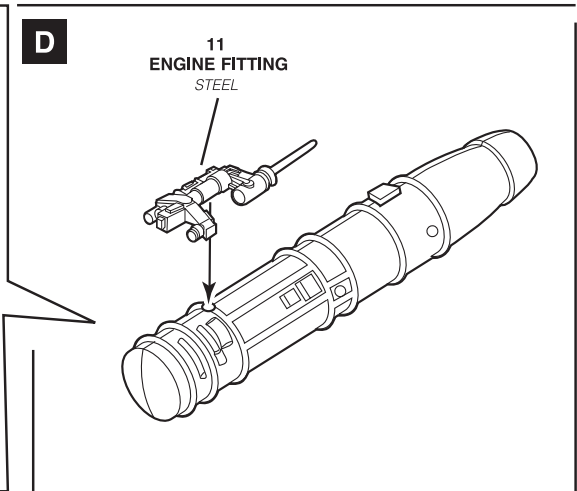
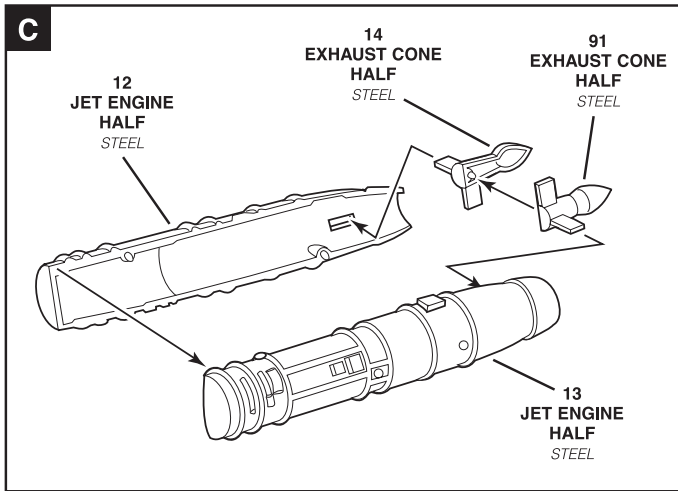
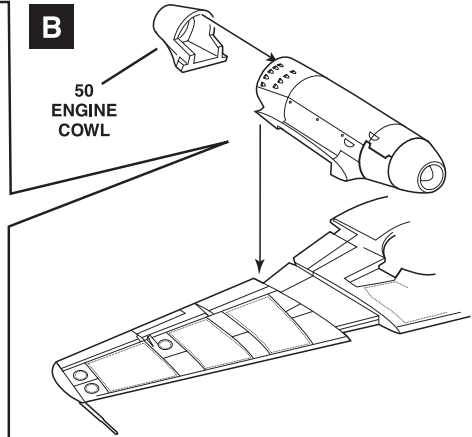
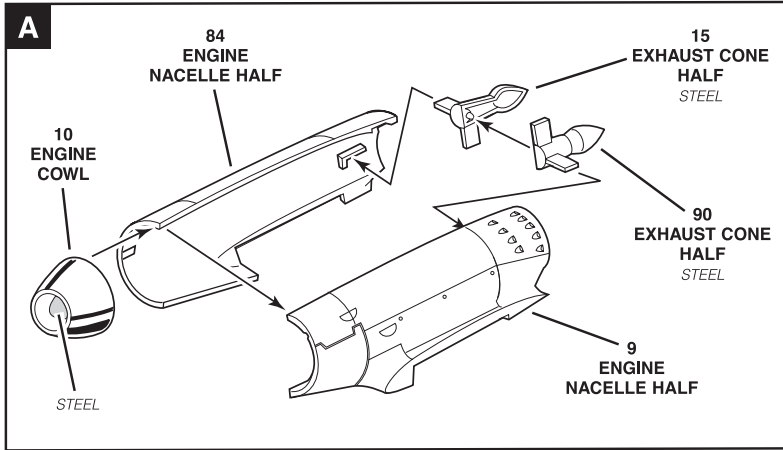

7

MAIN LANDING GEAR ASSEMBLY

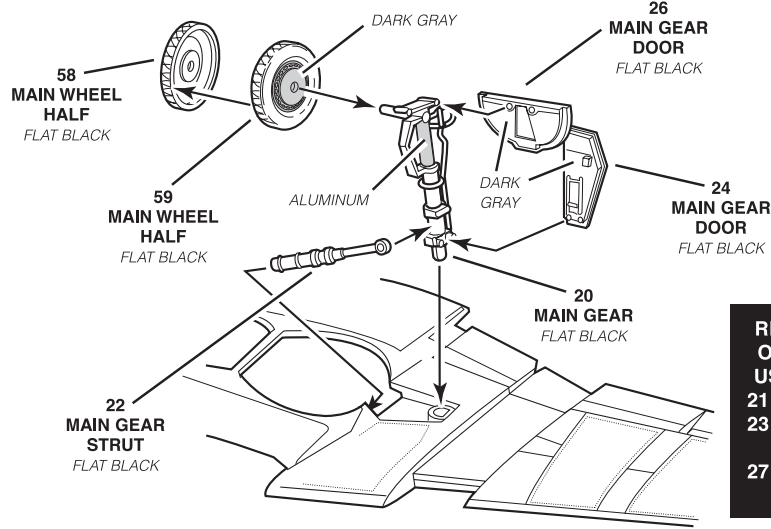

REPEAT FOR OTHER SIDE USING PARTS
21 MAIN GEAR
23 MAIN GEAR DOOR
27 MAIN GEAR DOOR

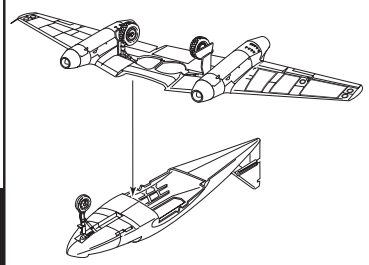

8

DOOR / ANTENNA ASSEMBLY

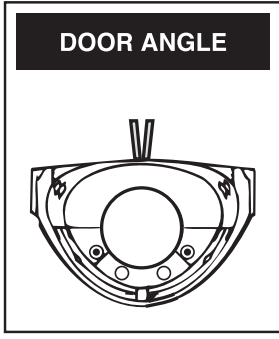
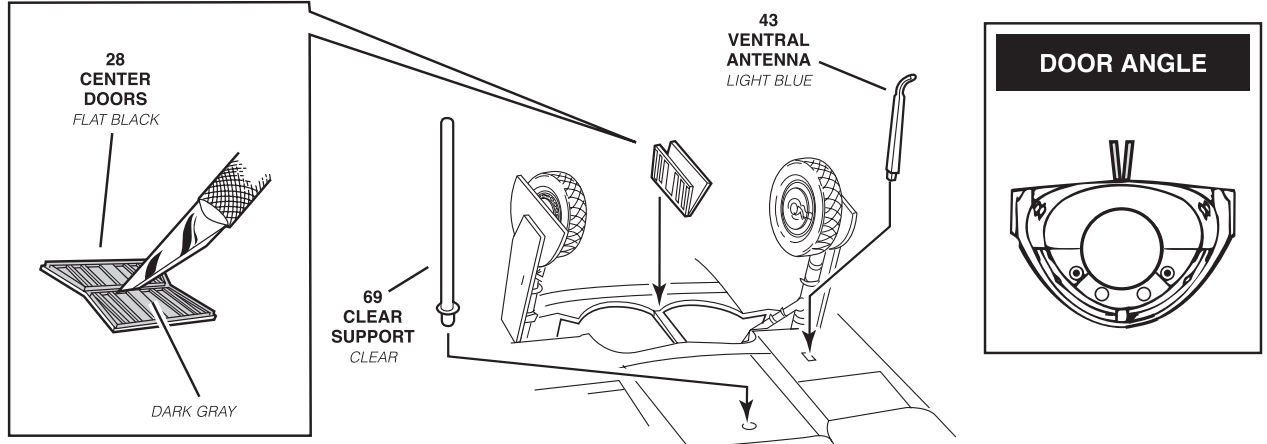

9

NOSE DOOR / STABILIZER ASSEMBLY

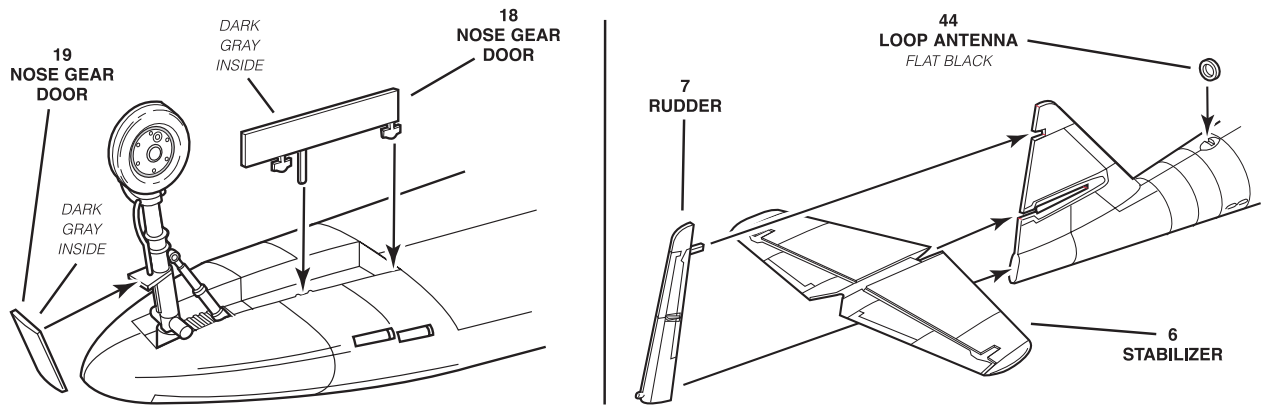

10

? BOMB ASSEMBLY

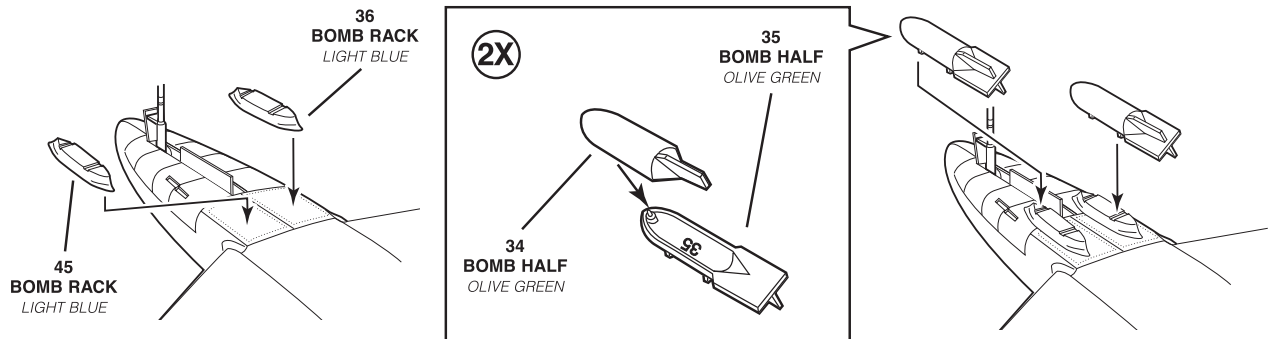

11

? ROCKET AND RACK ASSEMBLY

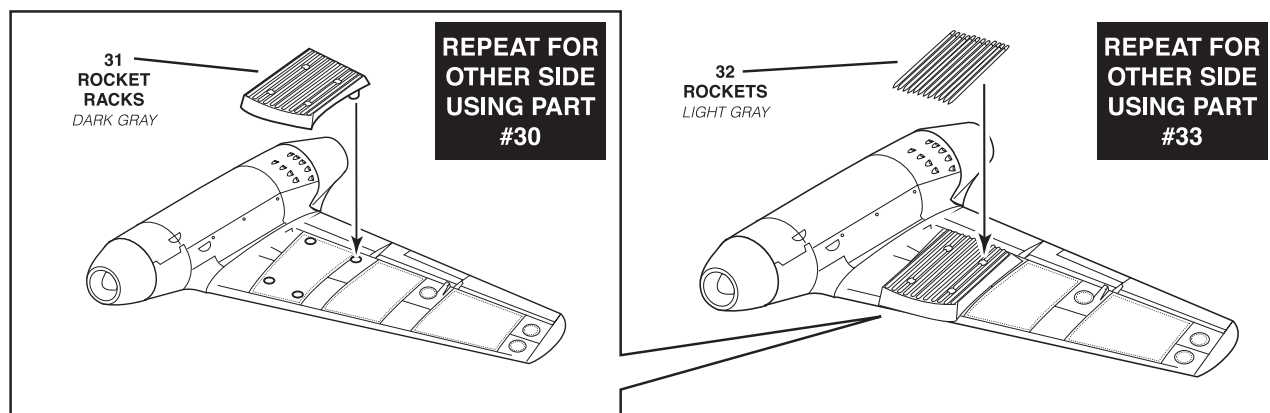

12

CANOPY ASSEMBLY

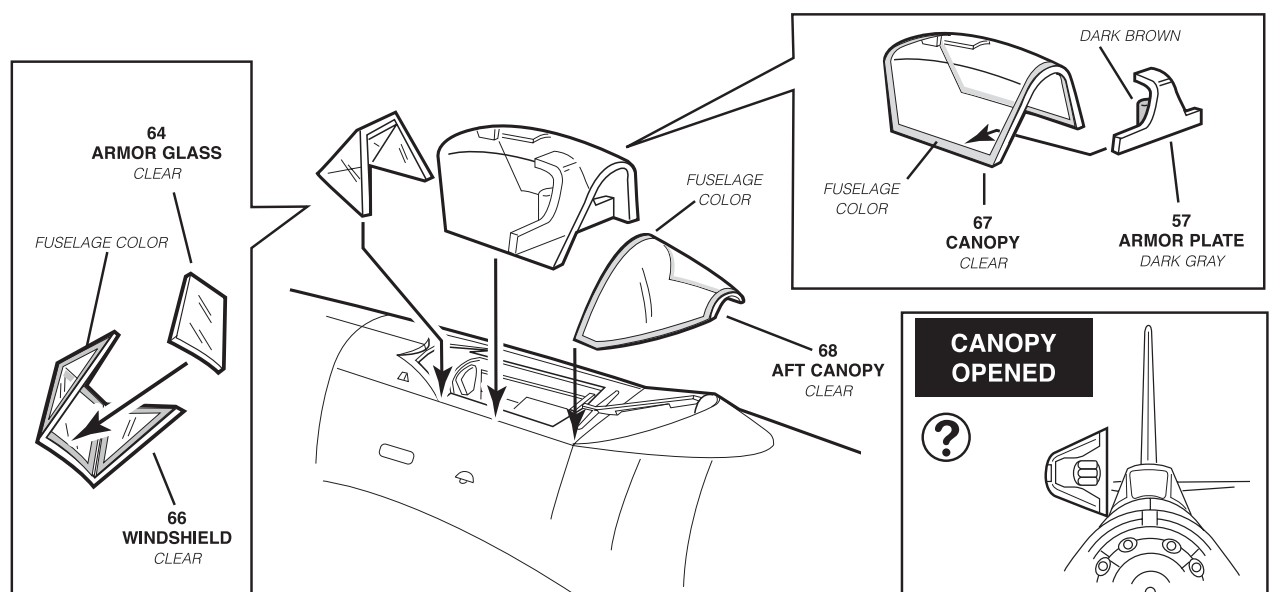

**ME 262A-1A, III./JG 7 NOWOTNY, PILOT OBERFELDWEBEL HEINZ ARNOLD,
PARCHIM, GERMANY, MARCH 1945**

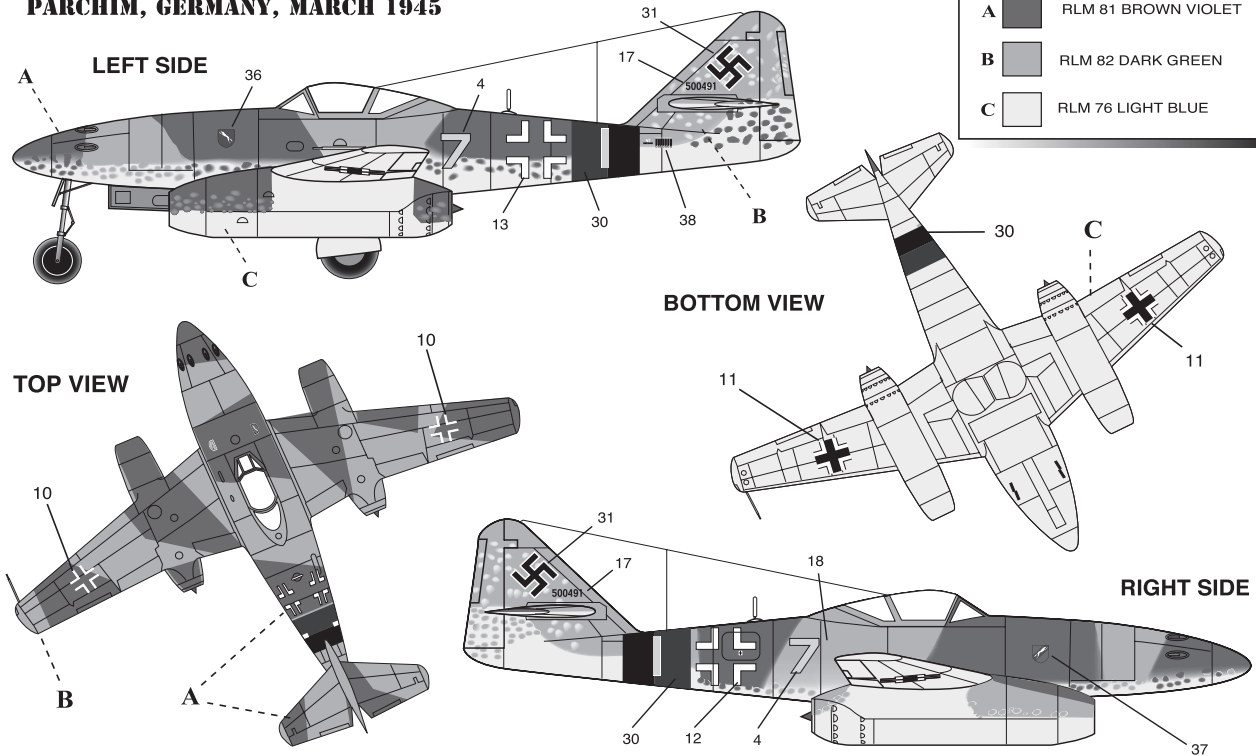

**ME 262A-1A, 7./KG(j) 54 TOTENKOPF
NEUBURG-ON-DANUBE, MARCH 1945**

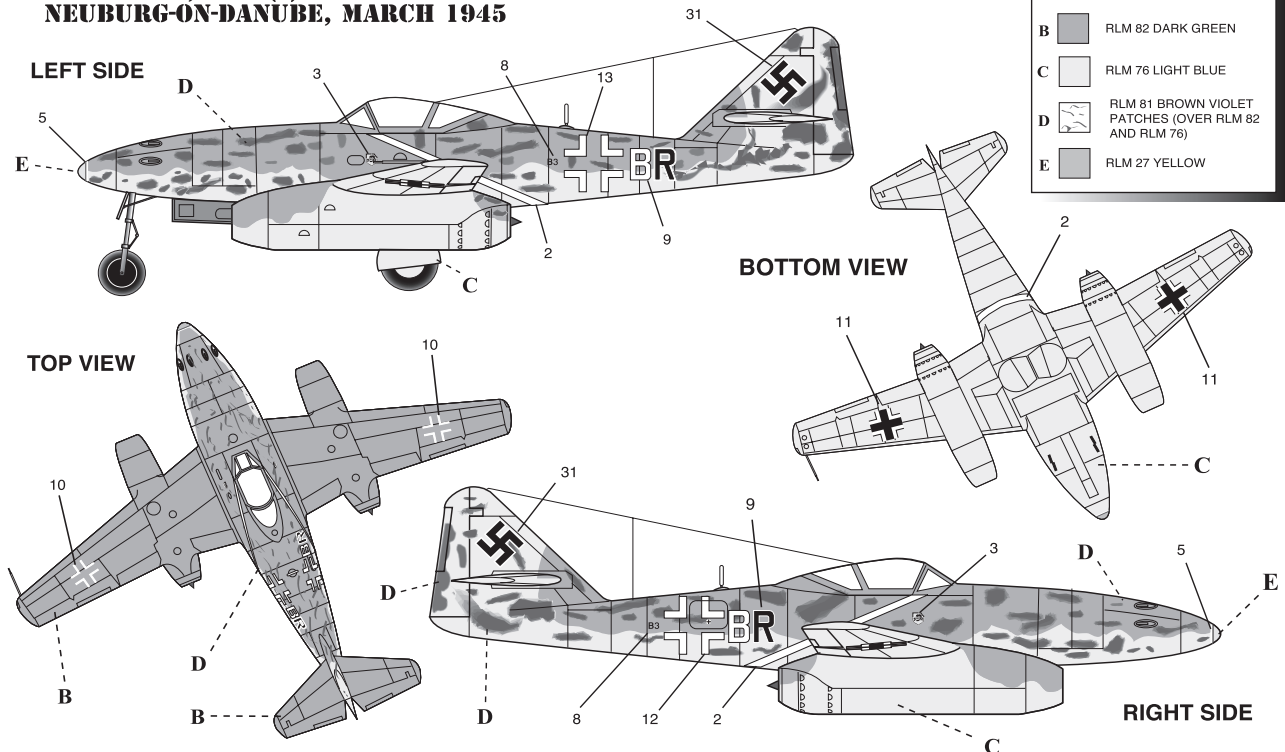

Me 262A-1a COMMON STENCIL PLACEMENT

LEFT SIDE

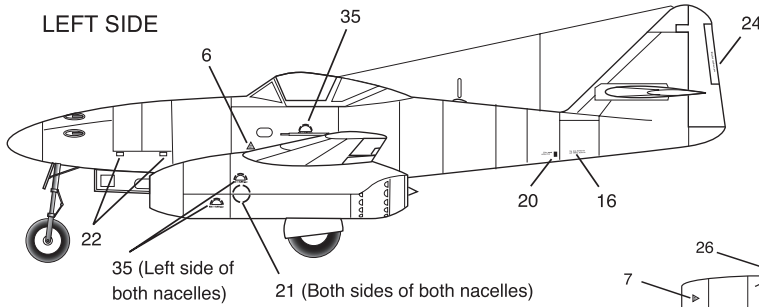

35 (Left side of both nacelles)
21 (Both sides of both nacelles)

1

INSTRUMENT PANEL AND COCKPIT INTERIOR

PAINT THE INSTRUMENT PANEL AND COCKPIT AIRCRAFT INTERIOR BLACK (TESTOR 4767) OR FS 37031

Make radio antenna from stretched sprue or fine wire after decals are in place and dry.

TOP VIEW

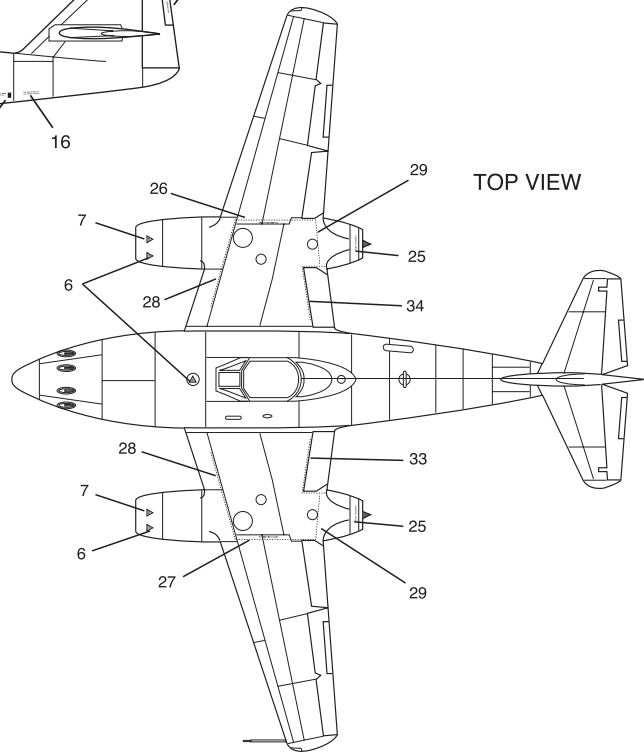

RIGHT SIDE

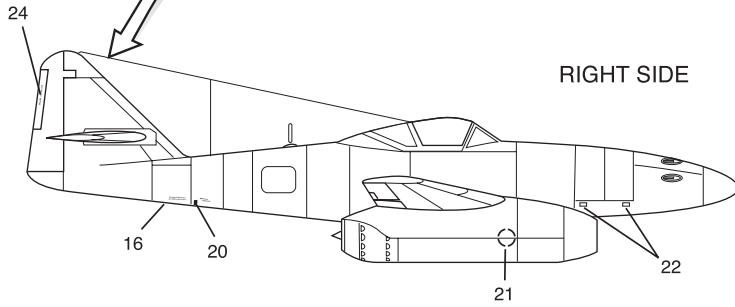

BOTTOM VIEW

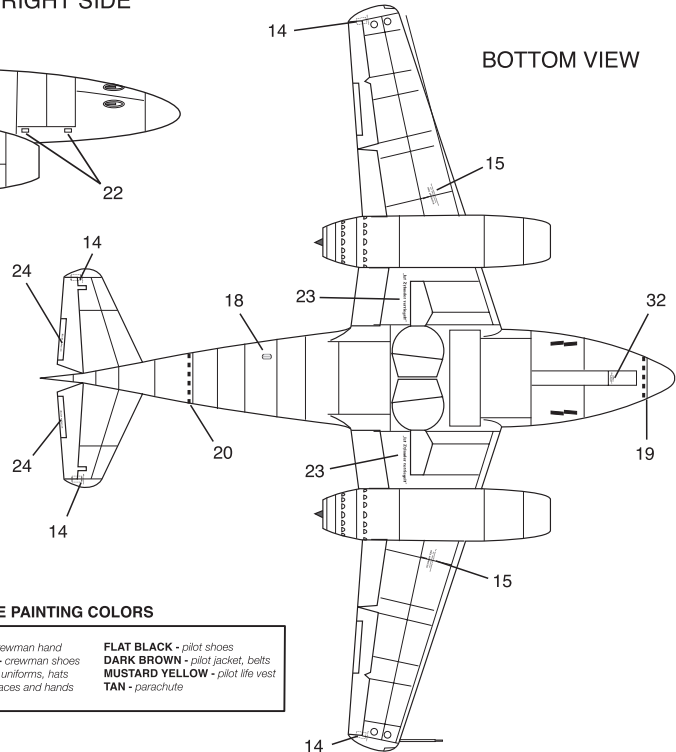

?

CREWMEN

52 PILOT
DARK GRAY

54 PILOT ARM
DARK GRAY

53 GROUND CREWMAN
DARK GRAY

FIGURE PAINTING COLORS

WHITE - rag in crewman hand
LIGHT BROWN - crewman shoes
OLIVE GREEN - uniforms, hats
SKIN COLOR - faces and hands

FLAT BLACK - pilot shoes
DARK BROWN - pilot jacket, belts
MUSTARD YELLOW - pilot life vest
TAN - parachute