



KIT 2825

85282500200

# John Greenwood's "Star and Stripes" Corvette® SEBRING 1971

One of the more notable names in Corvette® performance and racing history is John Greenwood. Like many American car enthusiasts in the late 1960's, John was a drag racing fan. However, once learning about and then trying out gymkhana type competition among non-professional drivers, John fell for road racing. At the time, he was driving a '68 Corvette® equipped with the special L-88 version of Chevy's® big block 427 engine, so he had some pretty heavy-duty hardware to start with.

Greenwood went off to school, road racing school that is, and gained his Sports Car Club of America (SCCA) competition license. Spending most of 1969 competing in regional SCCA events, John was a quick study. By 1970, he was competing and became national champion in A/ Production class, driving a 427 Corvette®. The choice of mount was completely predictable as not too many people

knew how to squeeze out more horsepower from a big block Chevy® V8 than John Greenwood.

For the 12 hours of Sebring race in 1971, John built a colorful red, white and blue C2 Corvette®. A roadster with the optional removable roof fastened on, the #48 was again powered by the mighty 427 V8. Along with co-driver Dick Smothers, the dark haired "straight man" to brother Tommy as half of the Smothers Brothers comedy duo of the 1960's, John came in first in GT class, coming in 7th overall.

It is this car as it competed at Sebring in 1971 that we present for you in this Revell-Monogram kit. It features many vintage racing parts as well as beautiful silkscreen decals produced by Cartograf of Italy to depict the "Stars and Stripes" paint scheme.



\* REPEAT SEVERAL TIMES  
\* A REPETER PLUSIEURS FOIS



\* OPTIONAL PARTS  
\* PIECES EN OPTION



\* DECAL  
\* DECAL COMANIE



\* ALTERNATIVE ASSEMBLY  
\* ENSEMBLAGE ALTERNATIVE



\* CEMENT TOGETHER  
\* A COLLER



\* REMOVE AND THROW AWAY  
\* A RETIRER ET JETER



\* DO NOT CEMENT  
\* NE PAS COLLER

### READ THIS BEFORE YOU BEGIN

- \* Study the assembly drawings.
- \* Each plastic part is identified by a number.
- \* In the assembly drawings, some parts will be marked by a star (★) to indicate chrome plated plastic.
- \* For better paint and decal adhesion, wash the plastic parts in a mild detergent solution. Rinse and let air dry.
- \* Check the fit of each piece before cementing in place.
- \* Use only cement for polystyrene plastic.
- \* Scrape plating and paint from areas to be cemented.
- \* Allow paint to dry thoroughly before handling parts.
- \* Any unused parts may be discarded.

### DECAL APPLICATION INSTRUCTIONS

1. Cut desired decal from sheet.
2. Dip decal in water for a few seconds.
3. Place wet decal on paper towel.
4. Wait until decal is movable on paper backing.
5. Place decal in position on model, face up and slide backing away.
6. Press out air bubbles with a soft damp cloth.
7. Milkiness that may appear is for better decal adhesion and will dry clear. Wipe away any excess adhesive.
8. Do not touch decal until fully dry.
9. Allow the decals 48 hours to dry before applying clear coat.

**NOTE:** Decals are compatible with setting solutions or solvents.

### LIRE CE QUI SUIT AVANT DE COMMENCER

- \* Etudier les schémas de montage.
- \* Chaque pièce en plastique est identifiée par un numéro.
- \* Sur les schémas de montage, certaines pièces sont marquées d'une étoile (★) pour indiquer qu'elles sont en plastique chromé.
- \* Pour une meilleure prise de la peinture et des autocollants, laver les pièces en plastique avec une solution détergente peu concentrée. Les rincer et les laisser sécher à l'air.
- \* Vérifier que chaque pièce s'ajuste bien avant de la coller en place.
- \* N'utiliser que de la colle pour polystyrène.
- \* Gratter les parties à coller pour enlever le chrome et la peinture.
- \* Laisser la peinture bien sécher avant de manipuler les pièces.
- \* Toute pièce inutilisée peut être jetée.

### DIRECTIVES D'APPLICATION DES AUTOCOLLANTS

1. Découper l'autocollant désiré de la feuille.
2. Tremper l'autocollant dans de l'eau pendant quelques secondes.
3. Placer l'autocollant mouillé sur une serviette en papier.
4. Attendez que l'autocollant puisse être déplacé sur son support en papier.
5. Mettre l'autocollant en position sur le modèle face sur le dessus et faire glisser le support pour l'enlever.
6. Appuyer avec un chiffon doux humide pour éliminer les bulles d'air.
7. La substance laiteuse qui peut apparaître est destinée à améliorer l'adhésion de l'autocollant et devient incolore au séchage. Essuyer pour enlever tout excédent d'adhésif.
8. Ne pas toucher l'autocollant tant qu'il n'est pas bien sec.
9. Laisser l'autocollant sécher pendant 48 heures avant d'appliquer une couche transparente.

**REMARQUE:** Les autocollants sont compatibles avec les solutions de fixation ou les solvants.

### This paint guide is provided to complete this kit as shown on the box.

Ce guide de peinture est fourni pour reproduire le modèle réduit qui apparaît sur la boîte.

Aluminum	Aluminium
Flat Black	Noir mat
Gloss Black	Blanc lustré
Gloss Light Gray	Gris clair lustré
Gloss Red	Rouge lustré
Gloss White	Blanc lustré
Graphite Metallic	Graphite métallisé
Gunmetal	Bronze
Semigloss Black	Noir satiné
Steel	Acier

If you have any questions or comments, call our hotline at: **(800) 833-3570**  
or, please write to:

**Revell-Monogram Consumer Service Department, 725 Landwehr Road, Northbrook, Illinois 60062**

Be sure to include the plan number (85282500200), part number, description, your return address and phone number.

Visit our website: [www.revell-monogram.com](http://www.revell-monogram.com)

# 1

# ENGINE ASSEMBLY

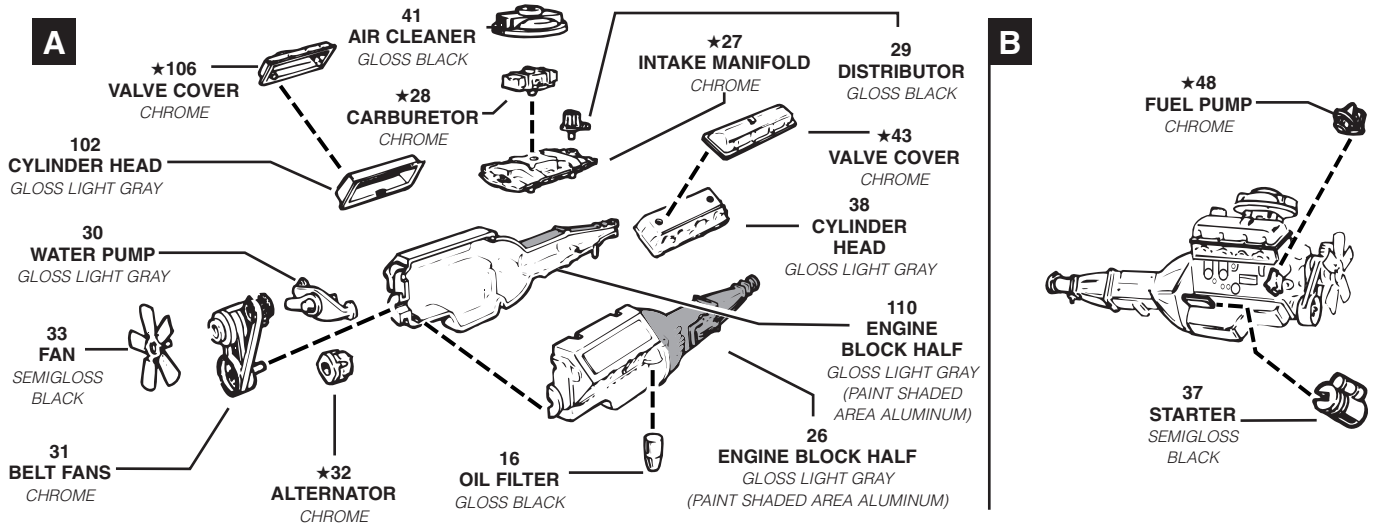

# 2

# REAR SUSPENSION ASSEMBLY

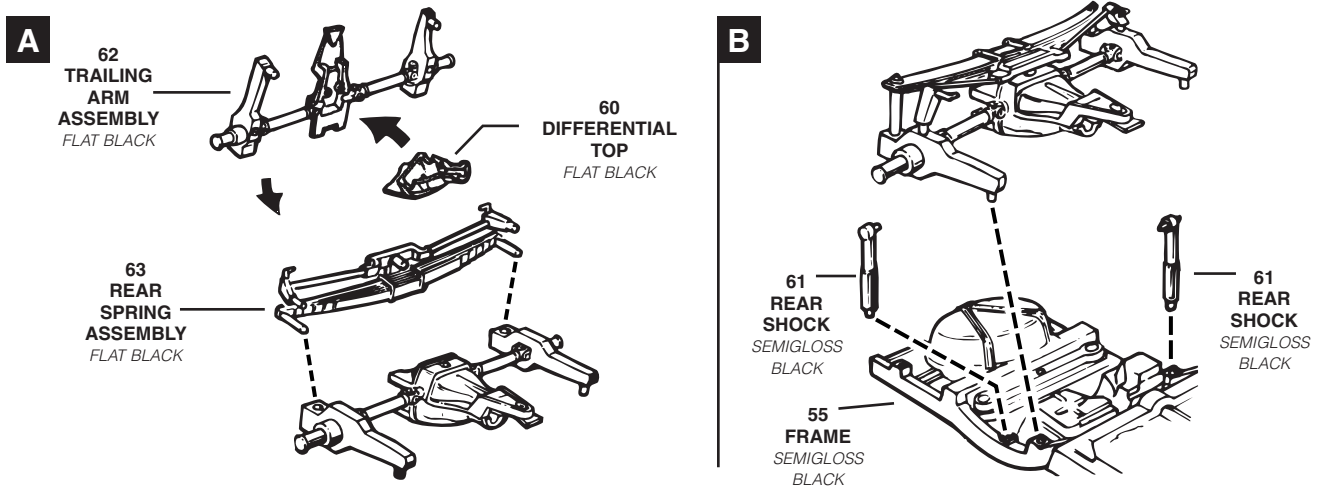

# 3

# FRONT SUSPENSION ASSEMBLY

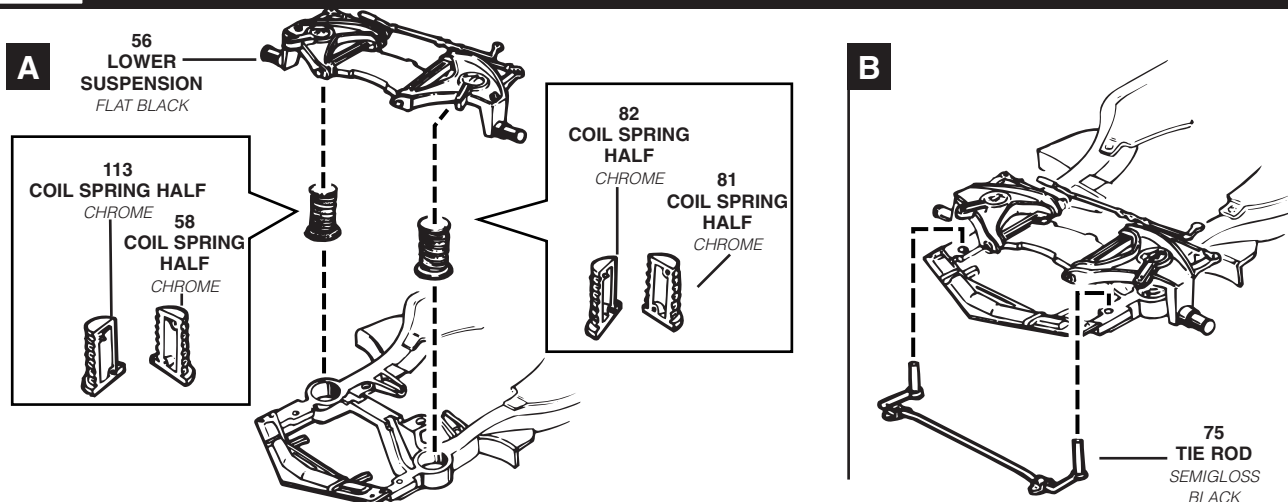

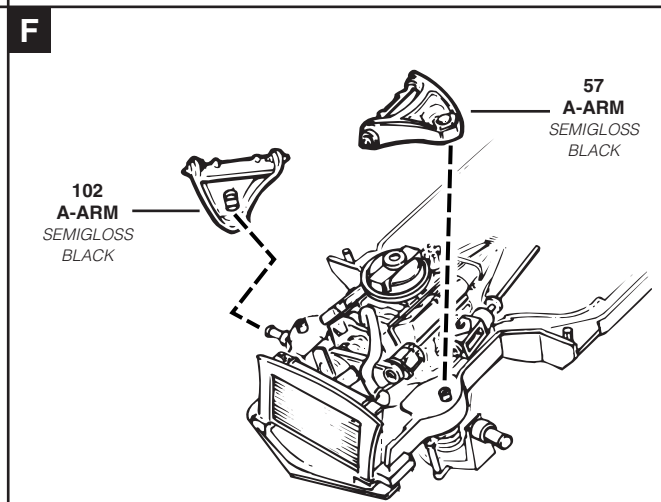
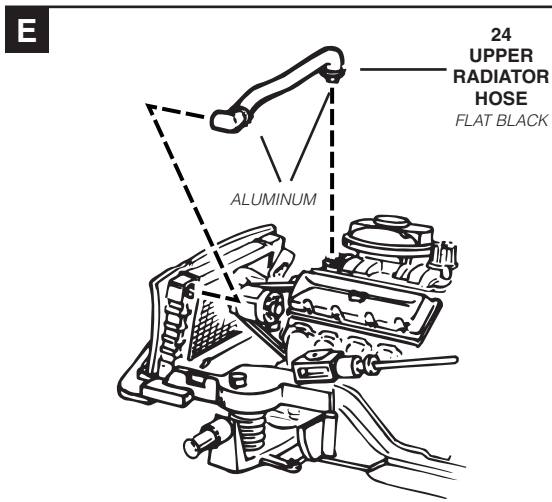
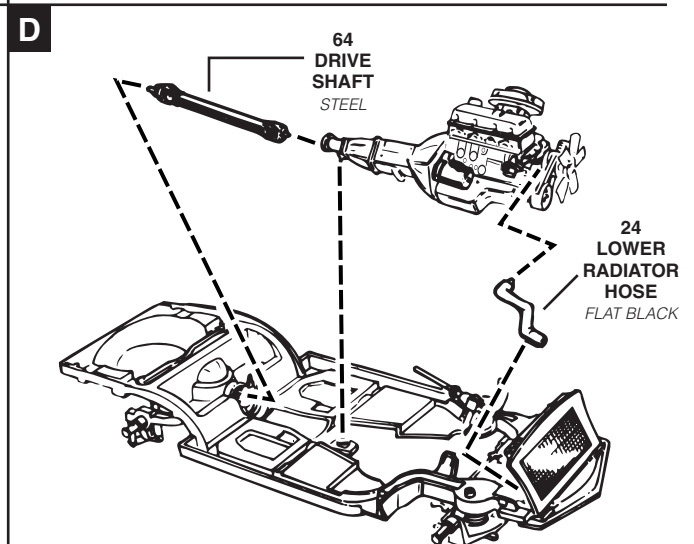
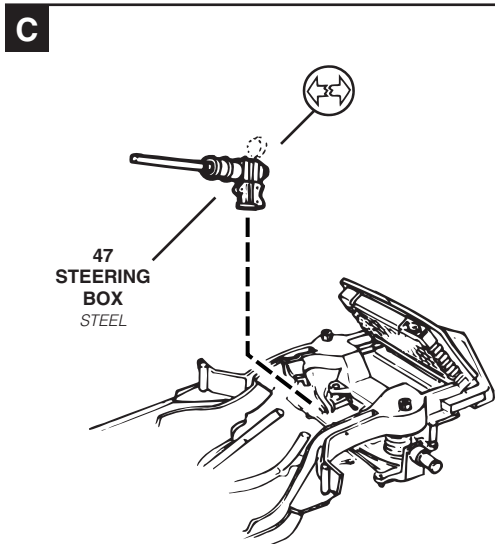
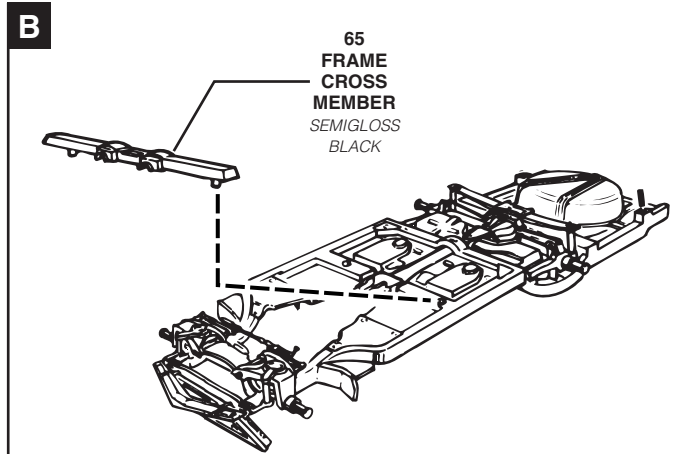
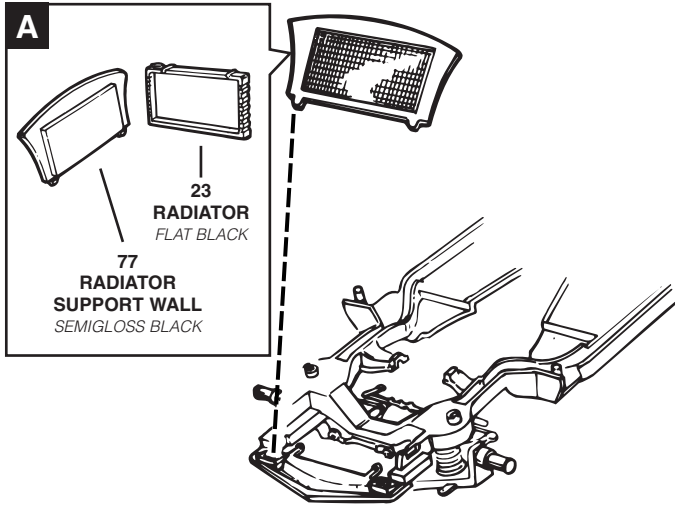

# 5

# WHEEL AND TIRE ASSEMBLY

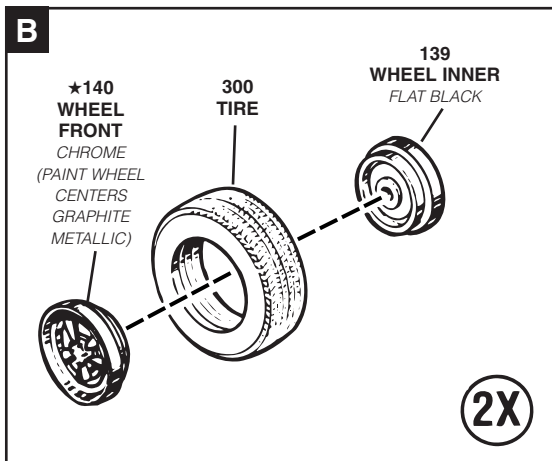
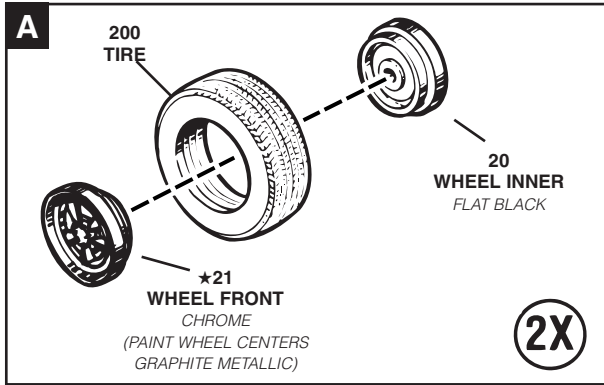

# 6

# INTERIOR ASSEMBLY

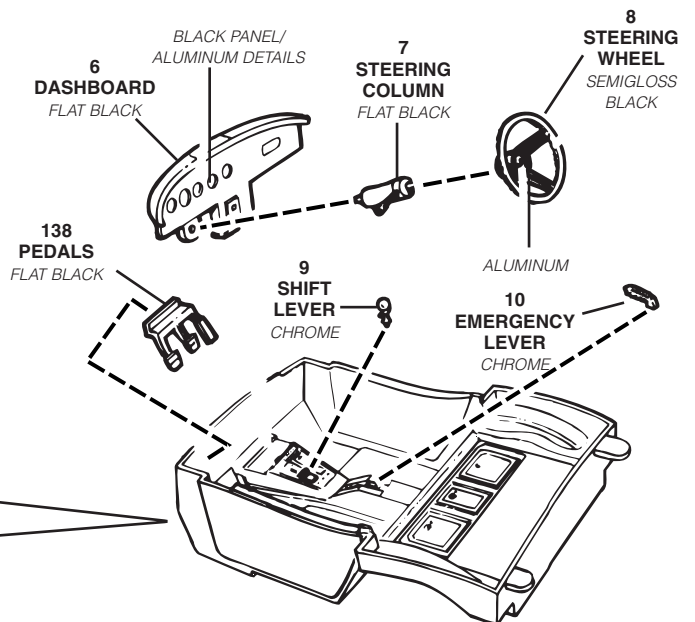
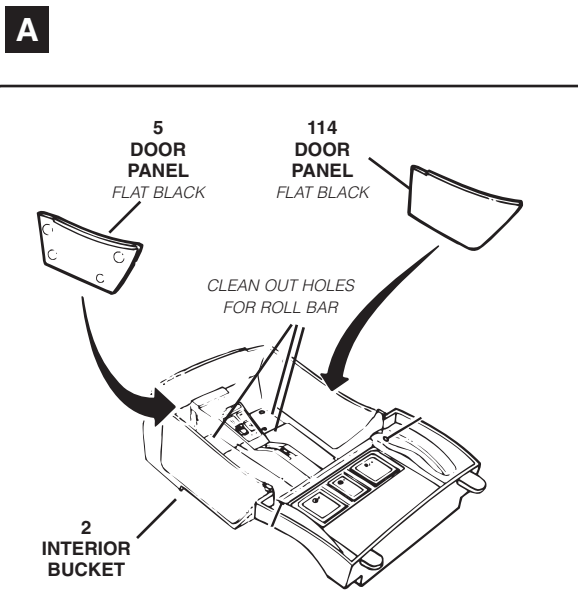

# 6

# INTERIOR ASSEMBLY CONTINUED

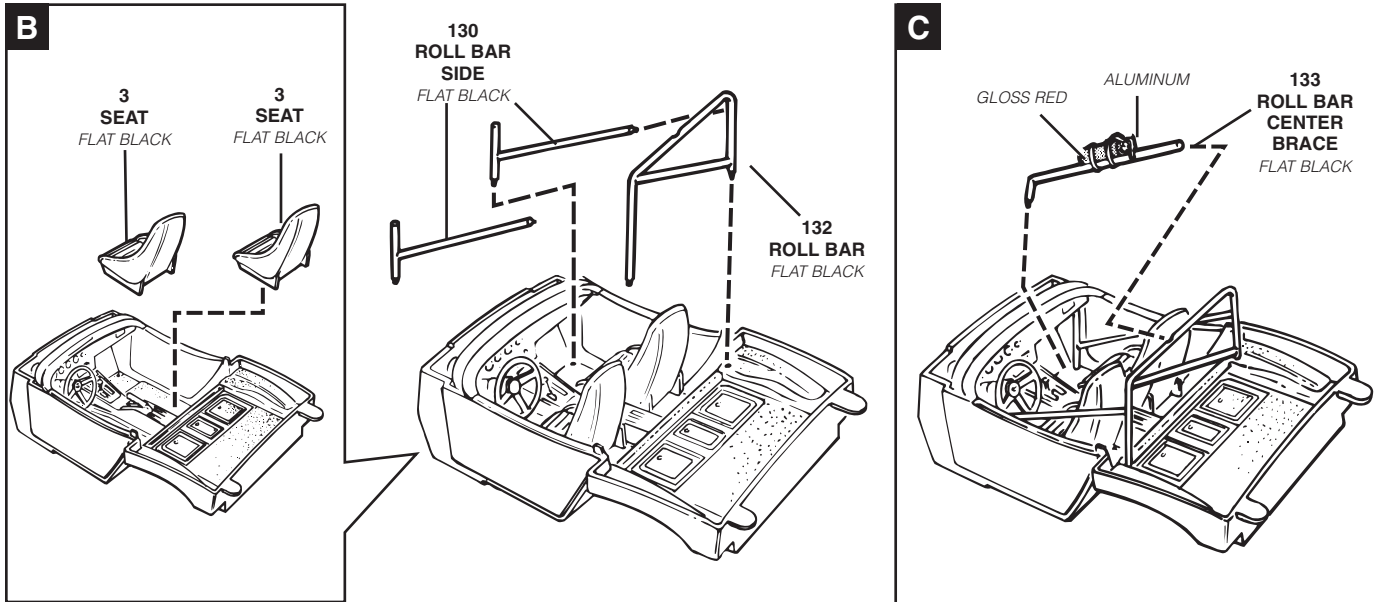

# 7

# BODY ASSEMBLY

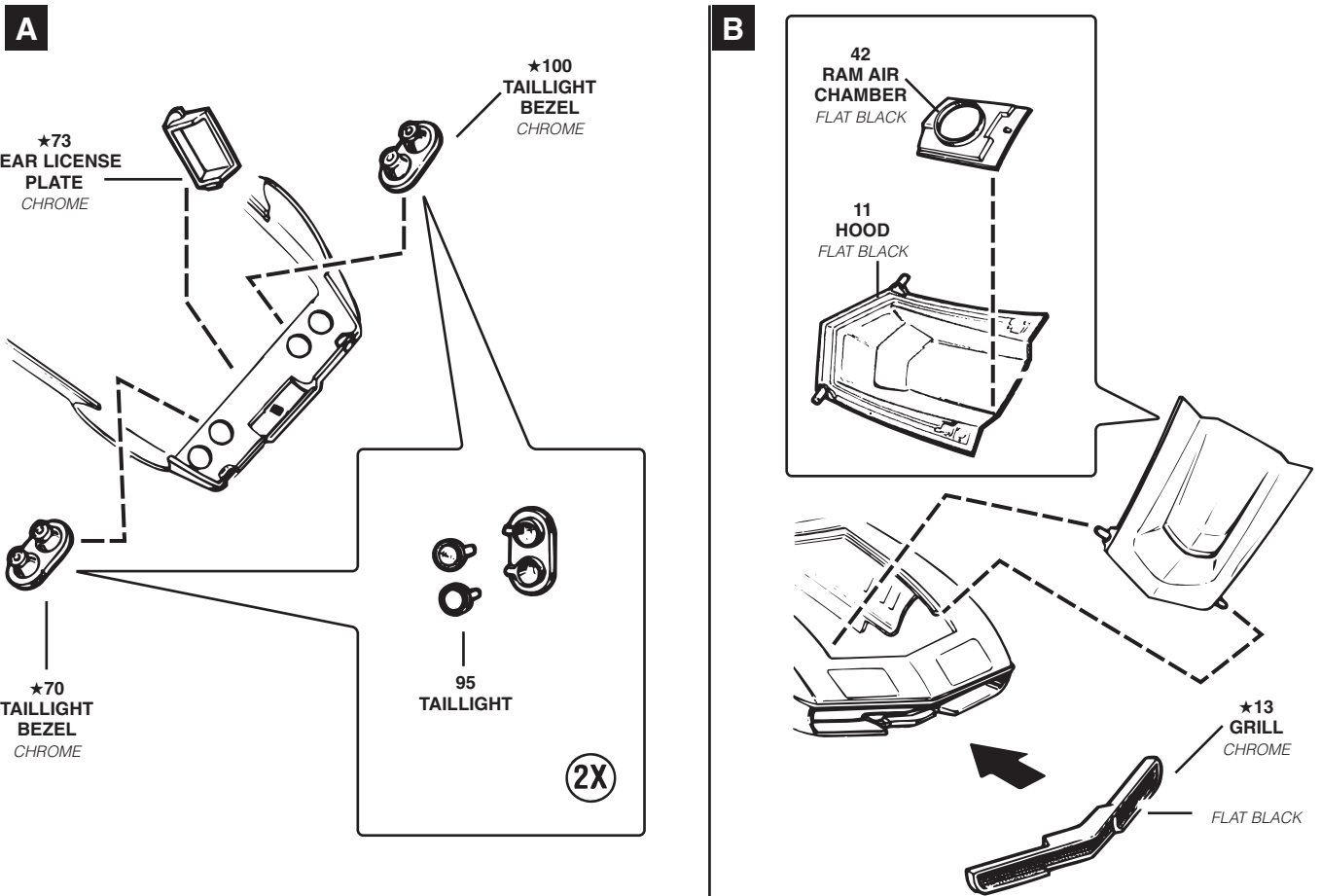

**C**

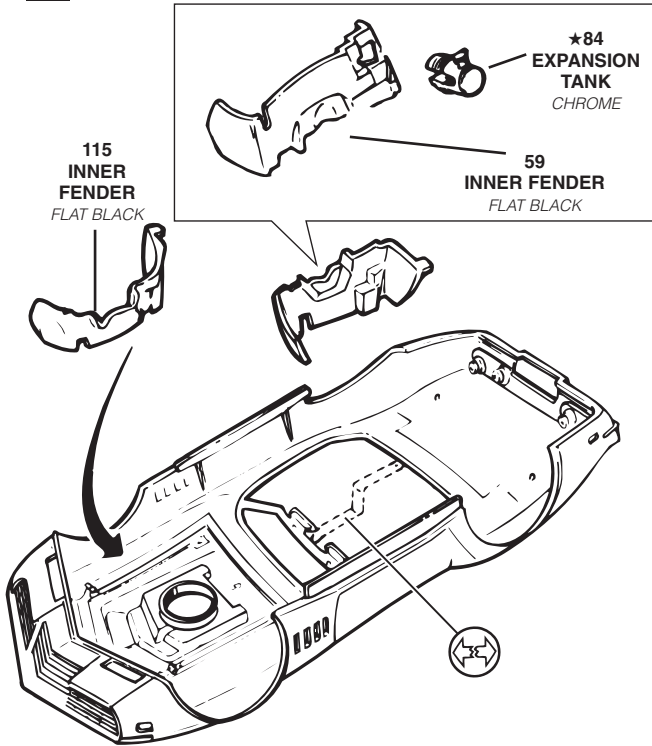

**D**

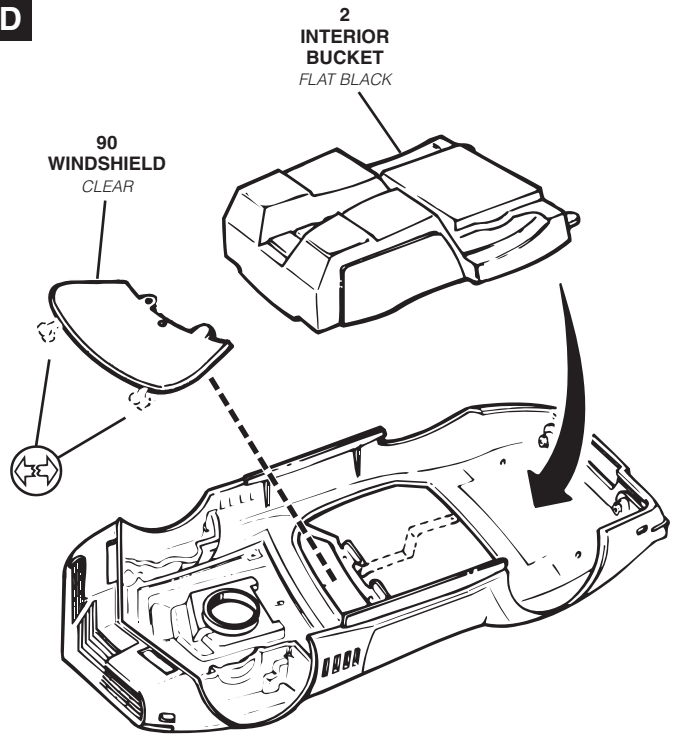

**E**

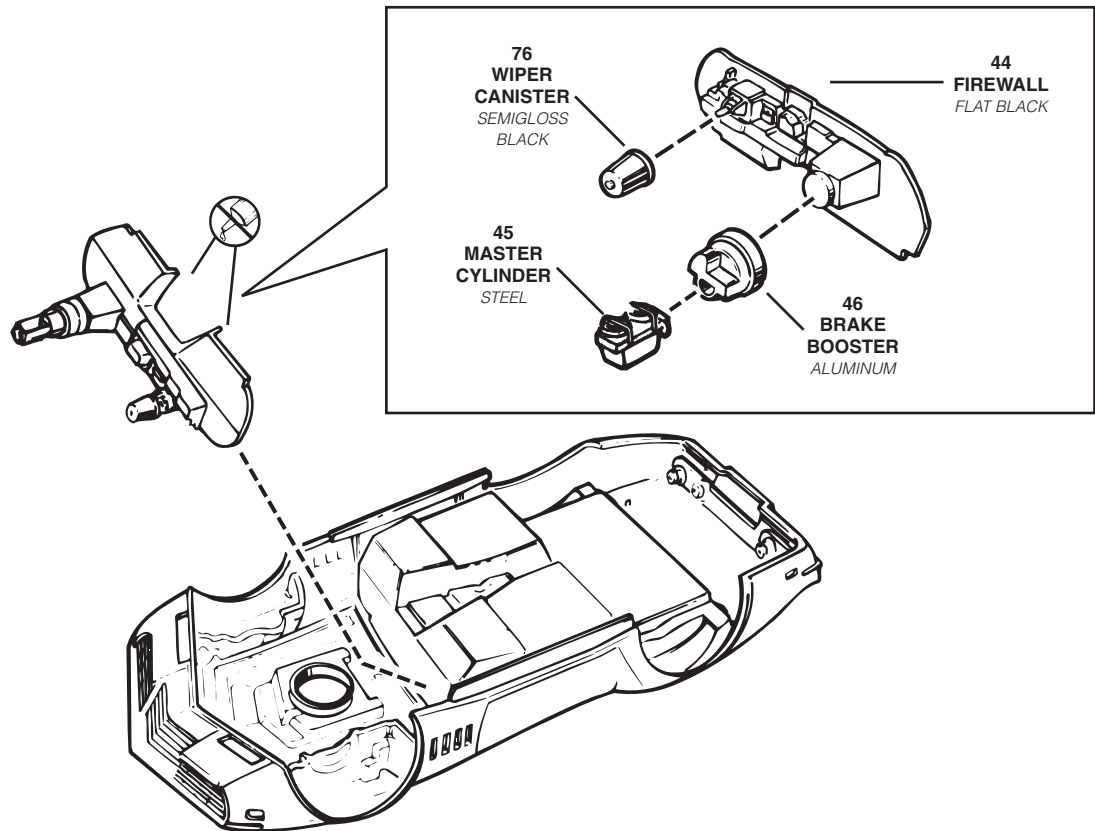

# 8

# CHASSIS AND BODY ASSEMBLY

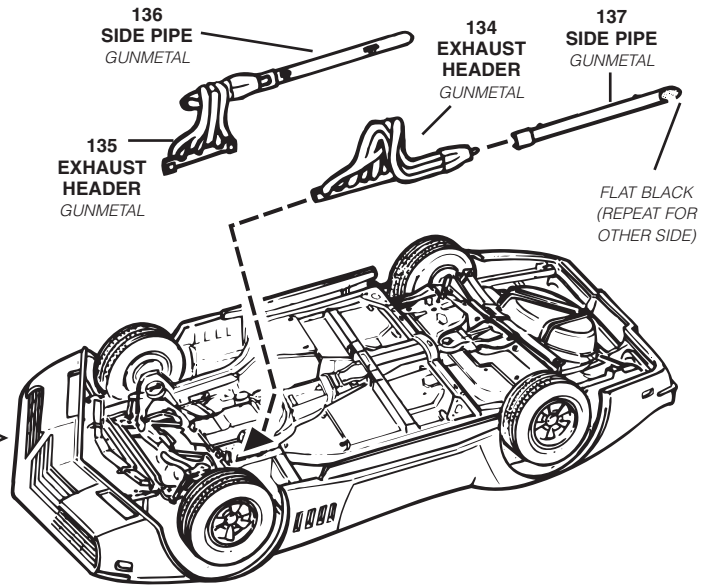
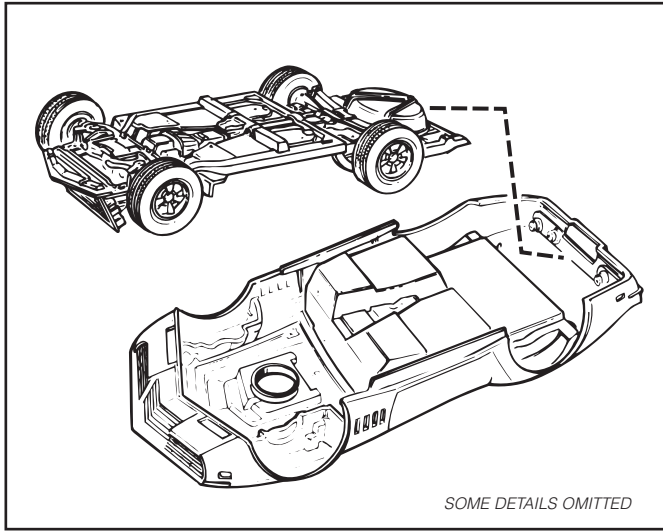

# 9

# FINAL ASSEMBLY

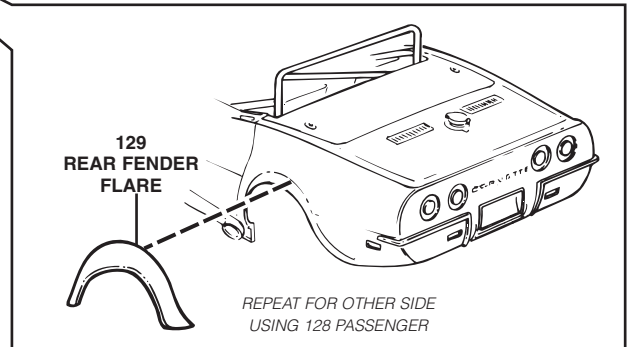
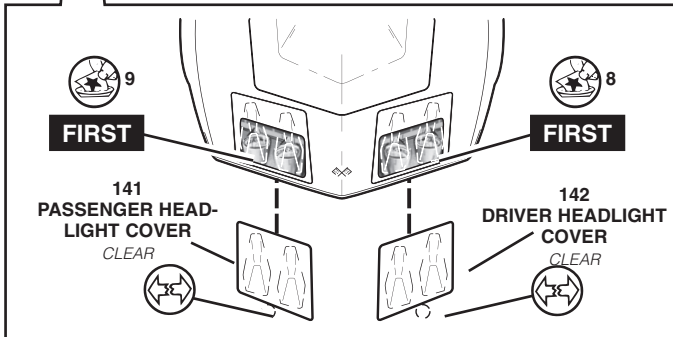
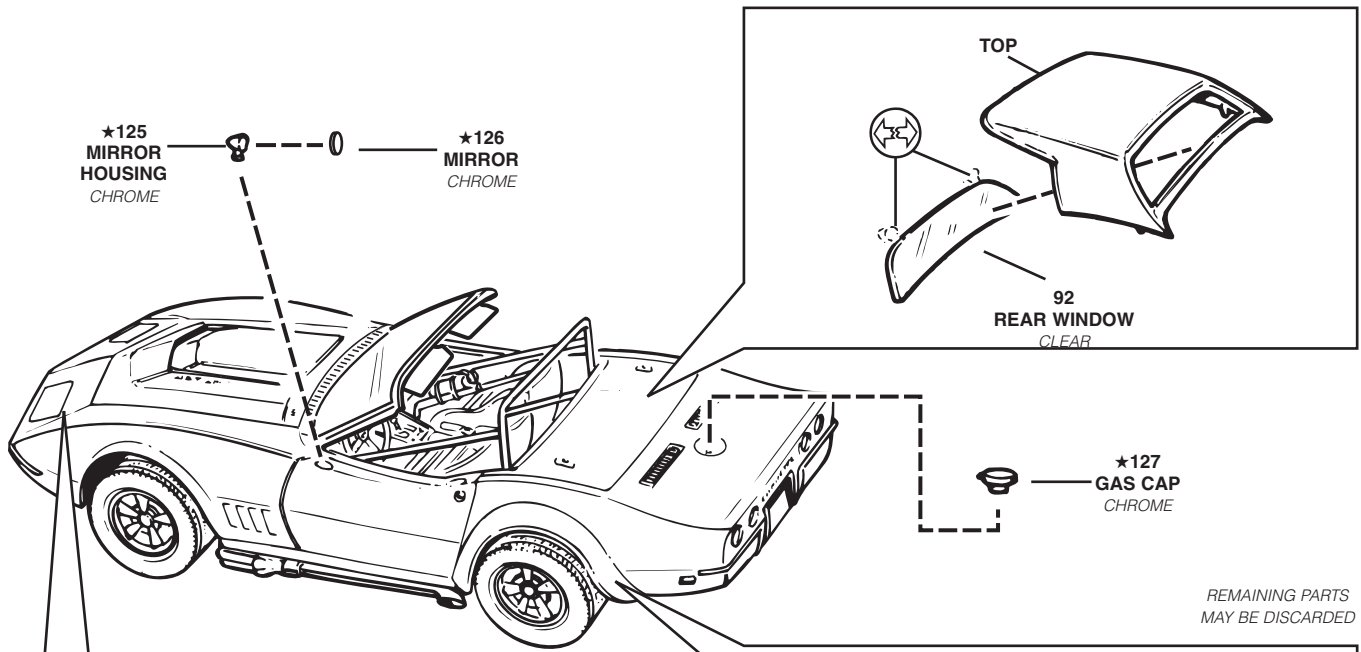



GLOSS WHITE

\* MUST BE APPLIED BEFORE CLEAR

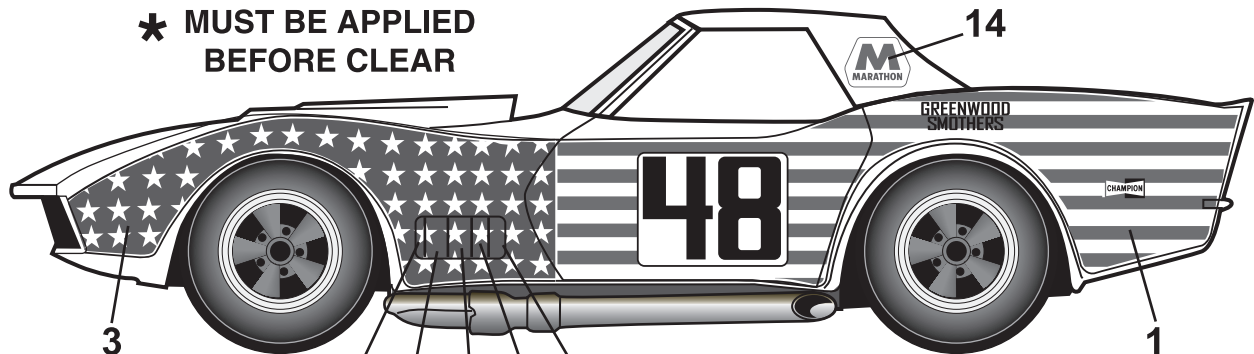

15,17,19,21,23 \*\*27 USE IF YOU CHOOSE TO PAINT VENTS INSTEAD OF DECALS

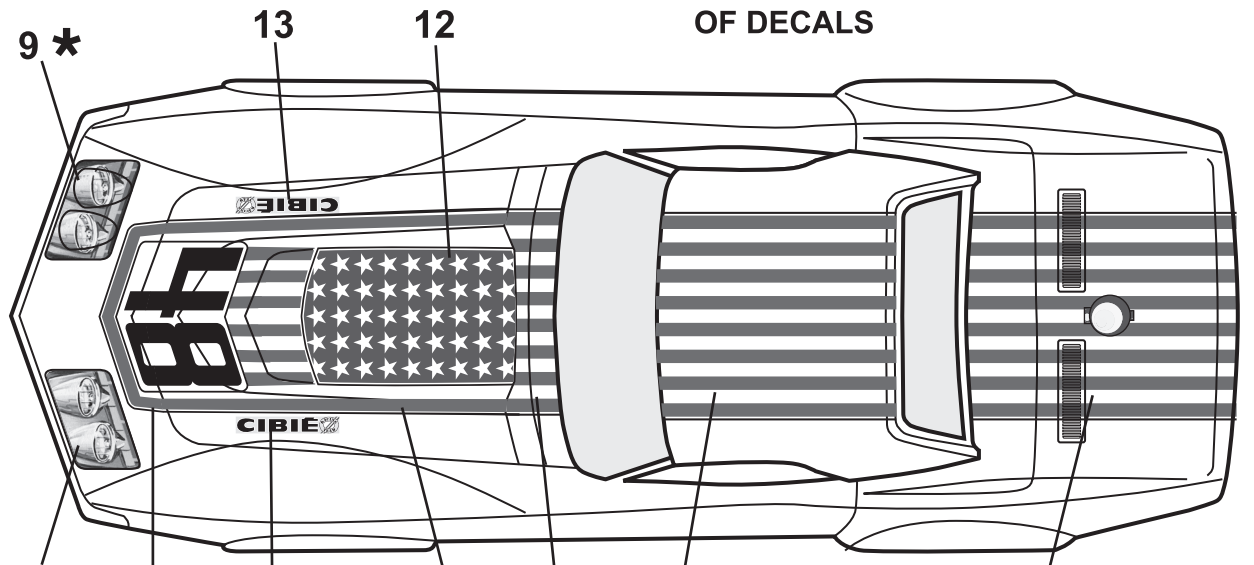

8\* 9\* 10 11 12 13 5 7 6 APPLY BEFORE ATTACHING HARDTOP  
 8 9 APPLY BELOW CLEAR HEADLIGHT COVERS IF NOT USING 25,26

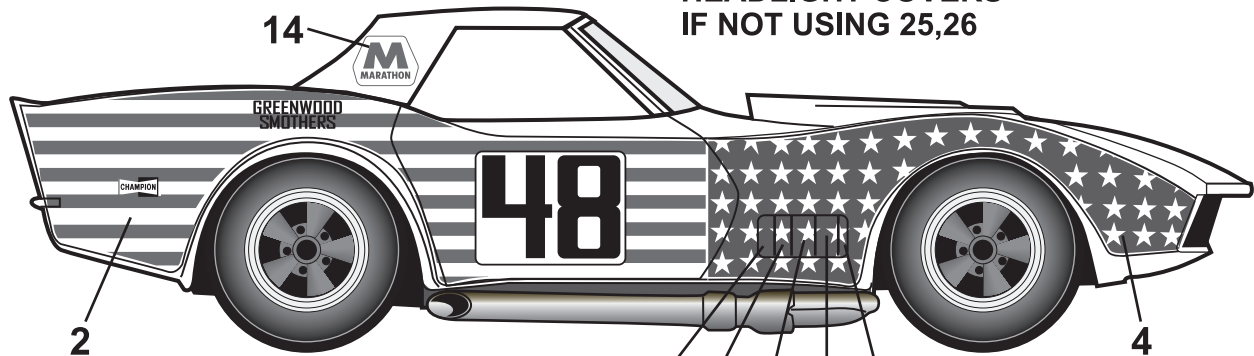

24,22,20,28,16  
 \*\*27 USE IF YOU CHOOSE TO PAINT VENTS INSTEAD OF DECALS

OPTION USE "DUCT TAPE" TO COVER HEADLIGHT COVERS

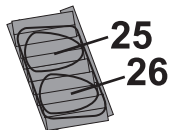

25  
 26