



KIT 2199

85219900200

# 40 Sterling Marlin

Coors LIGHT Dodge Intrepid R/T

Tennessee native Sterling Marlin's NASCAR® Cup career dates back to 1976, when he got his first opportunity to pilot a race car in relief of his father, Coo Coo Marlin after the elder Marlin broke his shoulder in a wreck. Back in the 1970's, locating a backup driver was not the task it is today what with sponsor approval and such. Mostly it meant looking around the garage area in search of a familiar face with a current NASCAR® license.

Sterling took to the family business right away, clinching ten victories along the way including back-to-back wins in the Great American Race, the Daytona 500 in 1994 and 1995. Sterling was

only the third driver in NASCAR® history to accomplish the feat, the others being Richard Petty and Cale Yarborough.

More recent times have found Sterling behind the controls of the mighty Dodge Intrepid owned by Chip Ganassi and sponsored by Coors Light®. This relationship has worked out well for everyone involved and especially for Dodge, scoring its first NASCAR® Cup victory since returning to the series with Sterling behind the wheel at the Michigan race back in August, 2001. The team finished up the 2003 campaign with eleven Top 10 finishes and renewed confidence that the silver #40 Intrepid will be parked in Victory Lane.



\* REPEAT SEVERAL TIMES  
\* A REPETER PLUSIEURS FOIS



\* OPTIONAL PARTS  
\* PIECES EN OPTION



\* DECAL  
\* DECAL COMANIE



\* ALTERNATIVE ASSEMBLY  
\* ENSEMBLAGE ALTERNATIVE



\* CEMENT TOGETHER  
\* A COLLER



\* REMOVE AND THROW AWAY  
\* A RETIRER ET JETER



\* DO NOT CEMENT  
\* NE PAS COLLER

### READ THIS BEFORE YOU BEGIN

- \* Study the assembly drawings.
- \* Each plastic part is identified by a number.
- \* In the assembly drawings, some parts will be marked by a star (★) to indicate chrome plated plastic.
- \* For better paint and decal adhesion, wash the plastic parts in a mild detergent solution. Rinse and let air dry.
- \* Check the fit of each piece before cementing in place.
- \* Use only cement for polystyrene plastic.
- \* Scrape plating and paint from areas to be cemented.
- \* Allow paint to dry thoroughly before handling parts.
- \* Any unused parts may be discarded.

### DECAL APPLICATION INSTRUCTIONS

1. Cut desired decal from sheet.
2. Dip decal in water for a few seconds.
3. Place wet decal on paper towel.
4. Wait until decal is movable on paper backing.
5. Place decal in position on model, face up and slide backing away.
6. Press out air bubbles with a soft damp cloth.
7. Milkyness that may appear is for better decal adhesion and will dry clear. Wipe away any excess adhesive.
8. Do not touch decal until fully dry.
9. Allow the decals 48 hours to dry before applying clear coat.

**NOTE:** Decals are compatible with setting solutions or solvents.

### LIRE CE QUI SUIT AVANT DE COMMENCER

- \* Etudier les schémas de montage.
- \* Chaque pièce en plastique est identifiée par un numéro.
- \* Sur les schémas de montage, certaines pièces sont marquées d'une étoile (★) pour indiquer qu'elles sont en plastique chromé.
- \* Pour une meilleure prise de la peinture et des autocollants, laver les pièces en plastique avec une solution détergente peu concentrée. Les rincer et les laisser sécher à l'air.
- \* Vérifier que chaque pièce s'ajuste bien avant de la coller en place.
- \* N'utiliser que de la colle pour polystyrène.
- \* Gratter les parties à coller pour enlever le chrome et la peinture.
- \* Laisser la peinture bien sécher avant de manipuler les pièces.
- \* Toute pièce inutilisée peut être jetée.

### DIRECTIVES D'APPLICATION DES AUTOCOLLANTS

1. Découper l'autocollant désiré de la feuille.
2. Tremper l'autocollant dans de l'eau pendant quelques secondes.
3. Placer l'autocollant mouillé sur une serviette en papier.
4. Attendez que l'autocollant puisse être déplacé sur son support en papier.
5. Mettre l'autocollant en position sur le modèle face sur le dessus et faire glisser le support pour l'enlever.
6. Appuyer avec un chiffon doux humide pour éliminer les bulles d'air.
7. La substance laiteuse qui peut apparaître est destinée à améliorer l'adhésion de l'autocollant et devient incolore au séchage. Essuyer pour enlever tout excédent d'adhésif.
8. Ne pas toucher l'autocollant tant qu'il n'est pas bien sec.
9. Laisser l'autocollant sécher pendant 48 heures avant d'appliquer une couche transparente.

**REMARQUE:** Les autocollants sont compatibles avec les solutions de fixation ou les solvants.

**This paint guide is provided to complete this kit as shown on the box.**

*Ce guide de peinture est fourni pour reproduire le modèle réduit qui apparaît sur la boîte.*

<b>Aluminum</b>	<i>Aluminium</i>
<b>Flat Black</b>	<i>Noir mat</i>
<b>Flat Red</b>	<i>Rouge mat</i>
<b>Gloss Red</b>	<i>Rouge brillant</i>
<b>Jet Exhaust</b>	<i>Flux d'éjection</i>
<b>Light Gray</b>	<i>Gris clair</i>
<b>Semigloss Black</b>	<i>Noir satiné</i>
<b>Silver Metallic</b>	<i>Argent métallisé</i>

**If you have any questions or comments, call our hotline at: (800) 833-3570 or, please write to:**

**Revell-Monogram Consumer Service Department, 725 Landwehr Road, Northbrook, Illinois 60062**

*Be sure to include the plan number (85219900200), part number, description, your return address and phone number.*

**Visit our website: [www.revell-monogram.com](http://www.revell-monogram.com)**

# 1

# ENGINE ASSEMBLY

## A

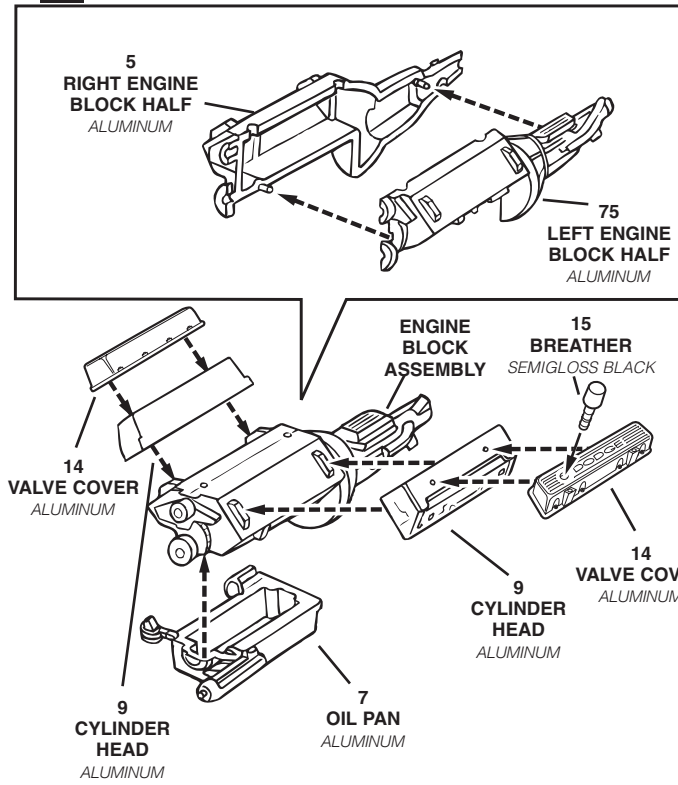

## B

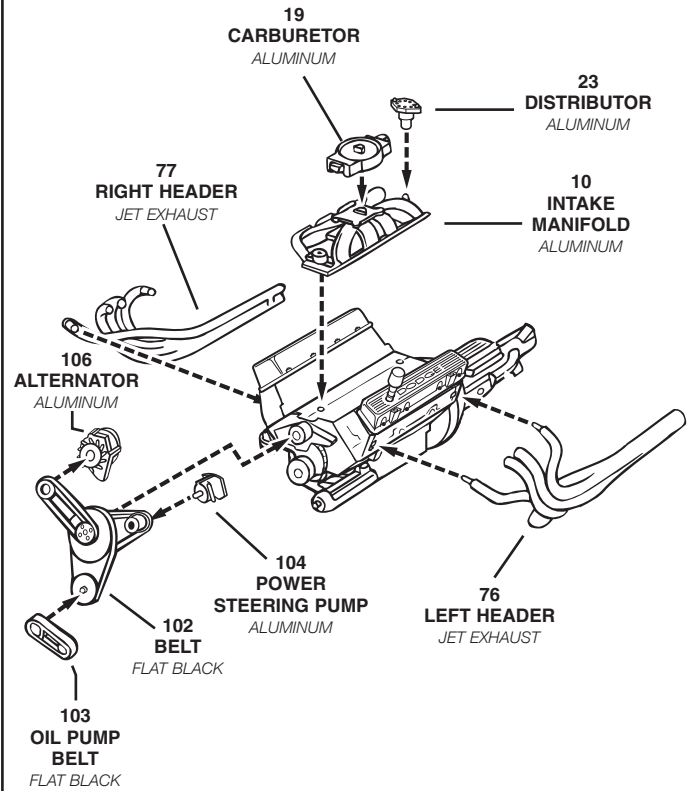

# 2

# CHASSIS ASSEMBLY

## A

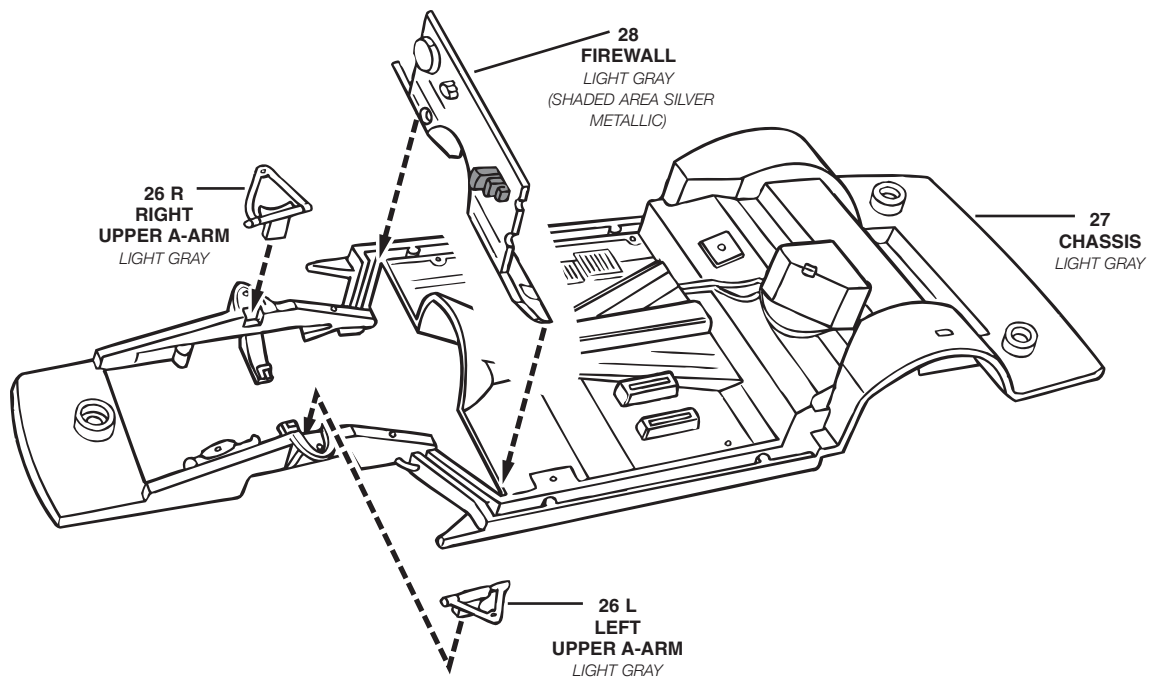

## B

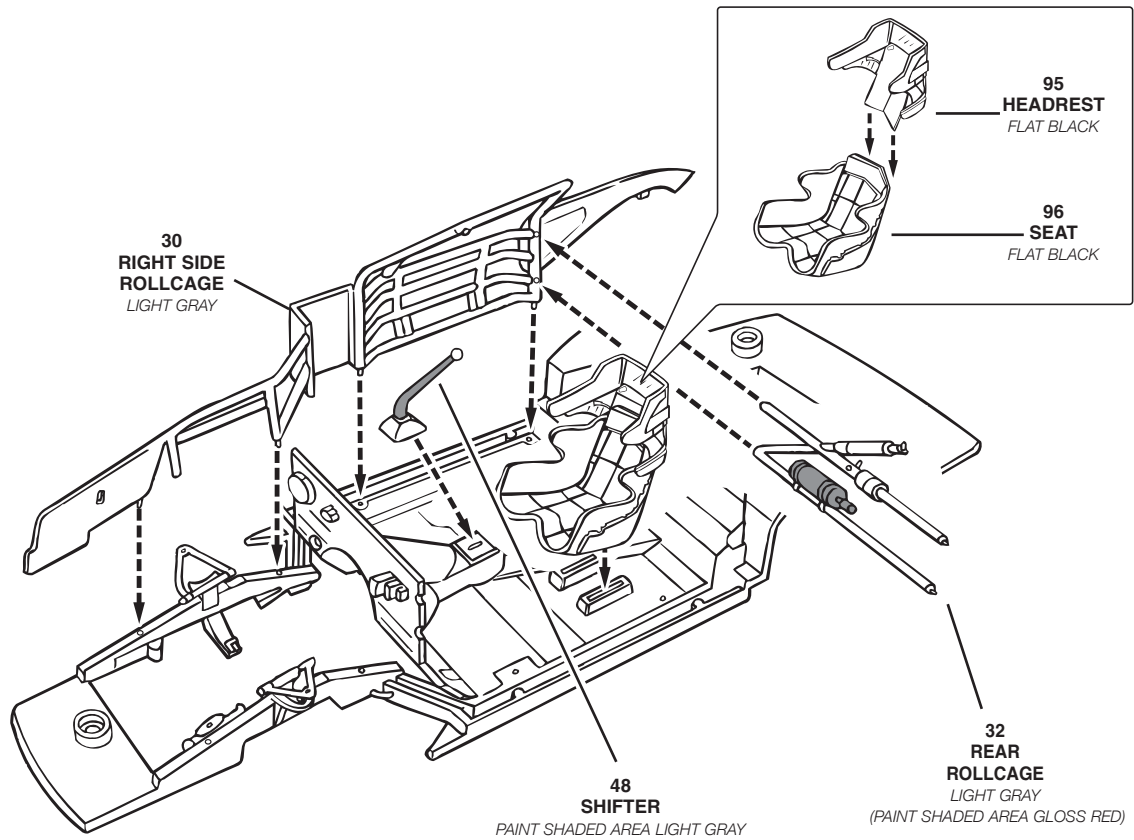

## C

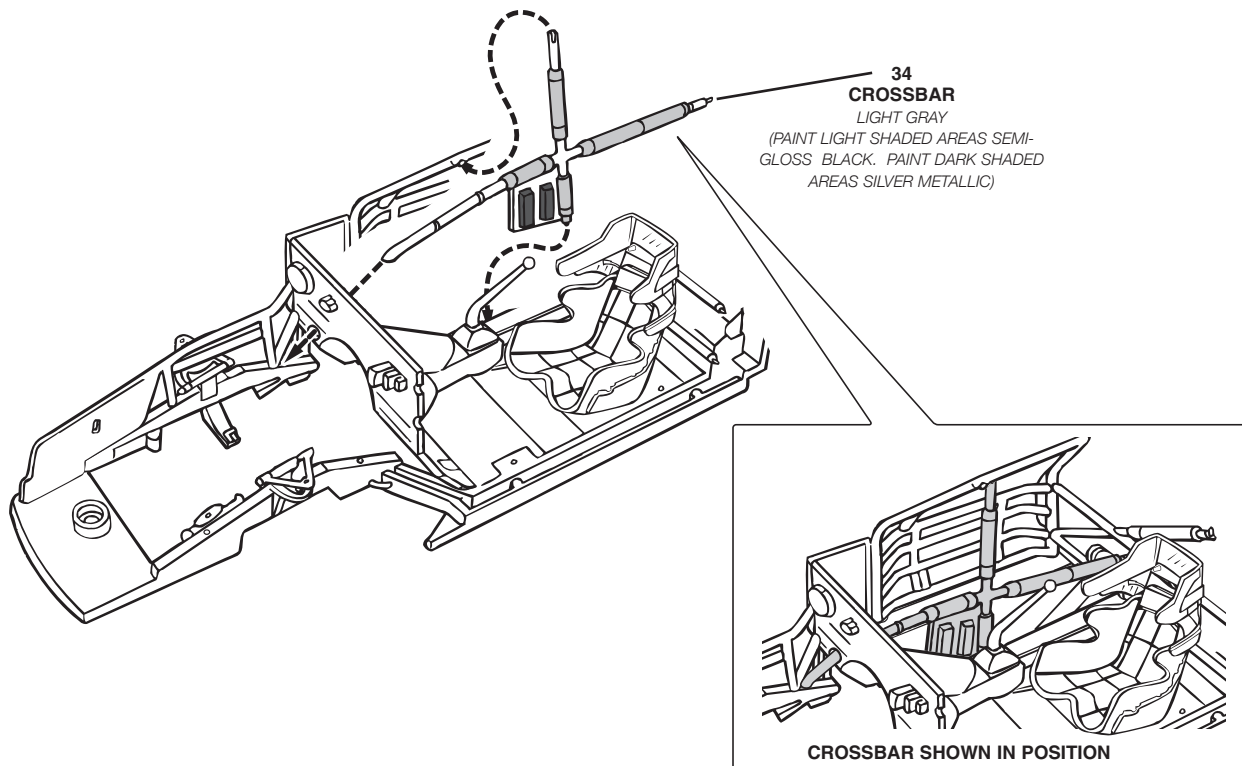

D

NOTE: DRIVER DECALS MUST BE APPLIED BEFORE CEMENTING FIGURE TO CHASSIS

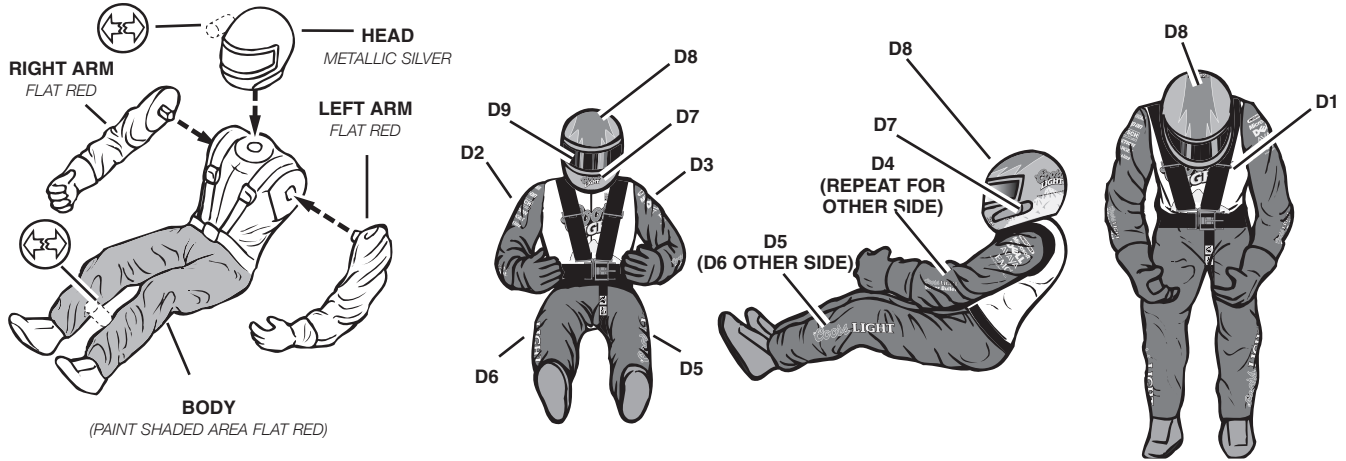

E

DRIVER ASSEMBLY

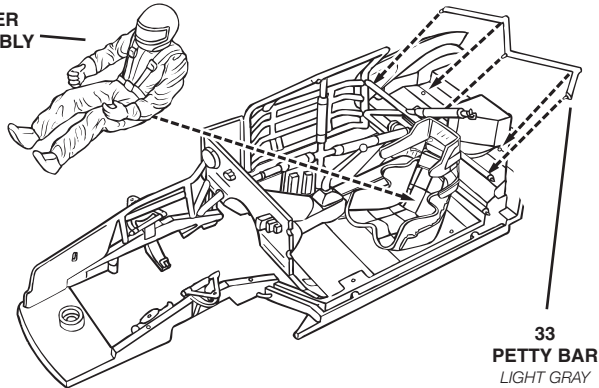

F

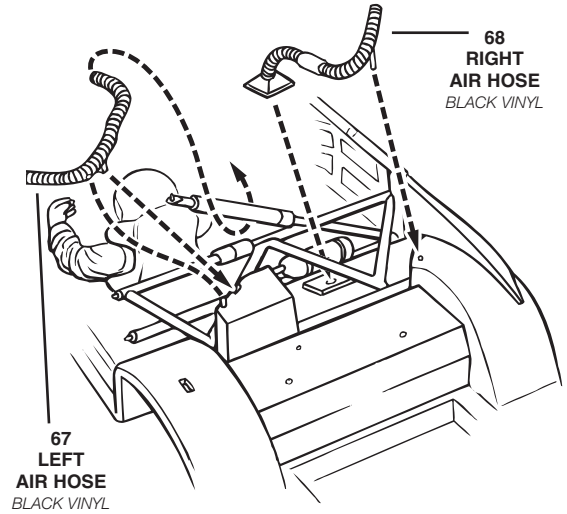

G

29 LEFT SIDE ROLL CAGE  
LIGHT GRAY  
(PAINT SHADED AREAS SEMIGLOSS BLACK)

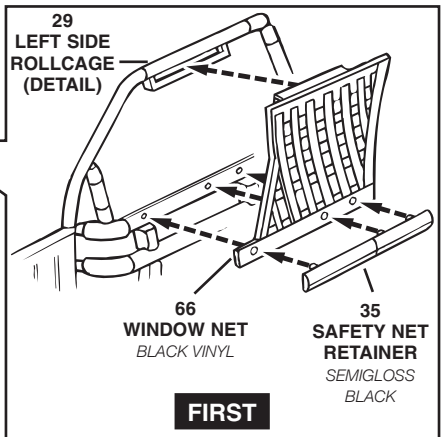
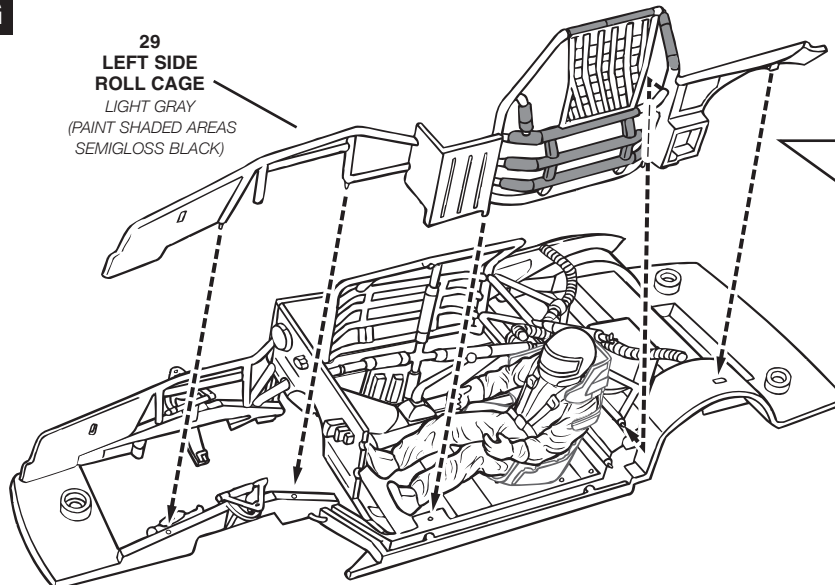

# 2

# CHASSIS ASSEMBLY CONTINUED

H

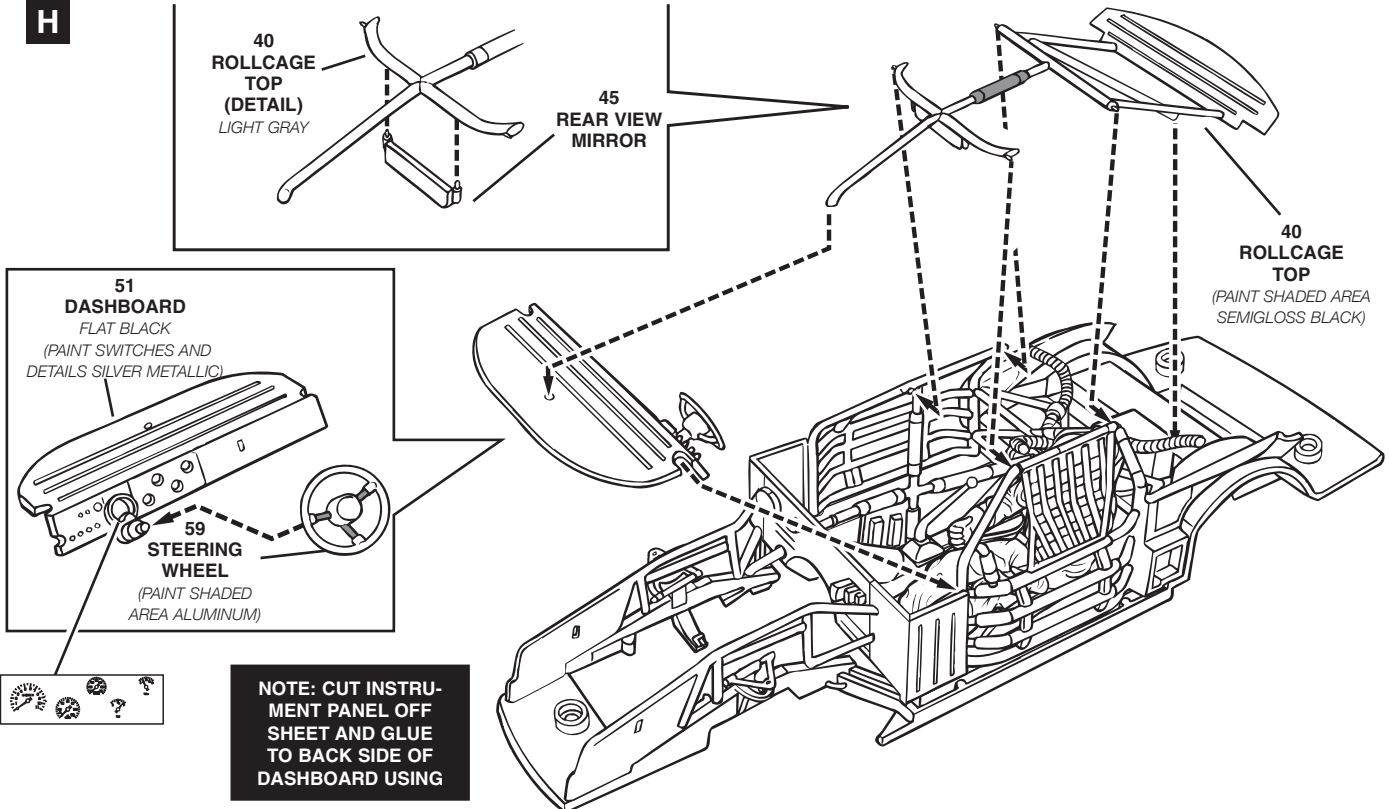

# 3

# REAR SUSPENSION ASSEMBLY

A

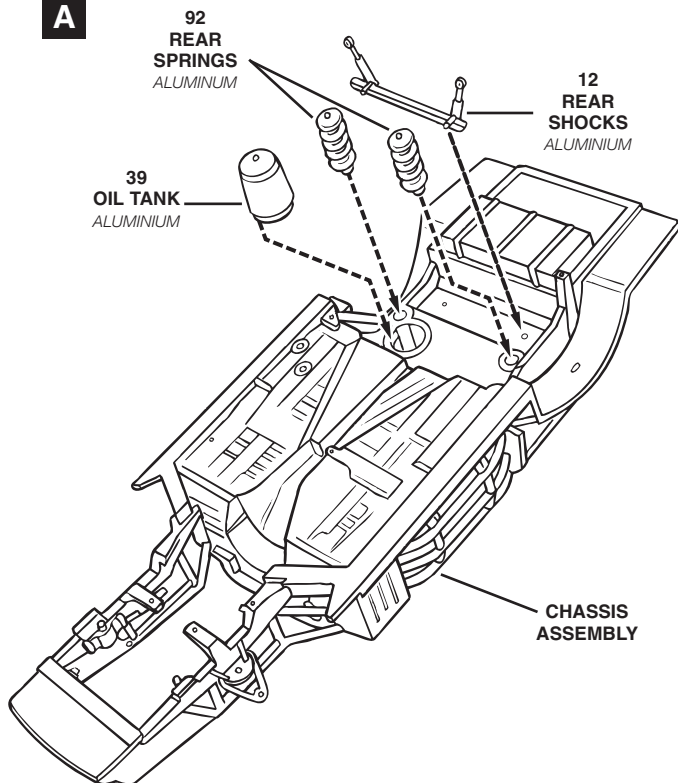

B

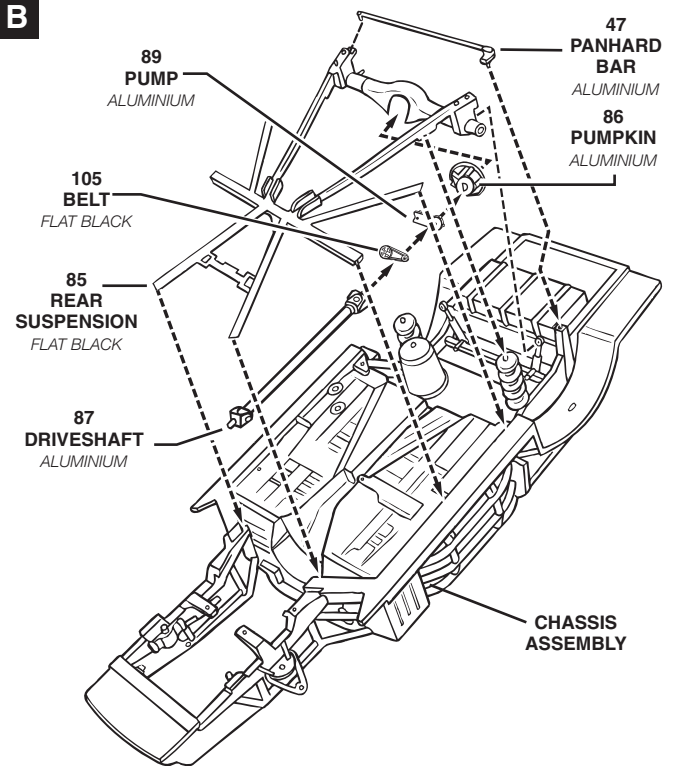

# 4

# DRIVETRAIN ASSEMBLY

**A**

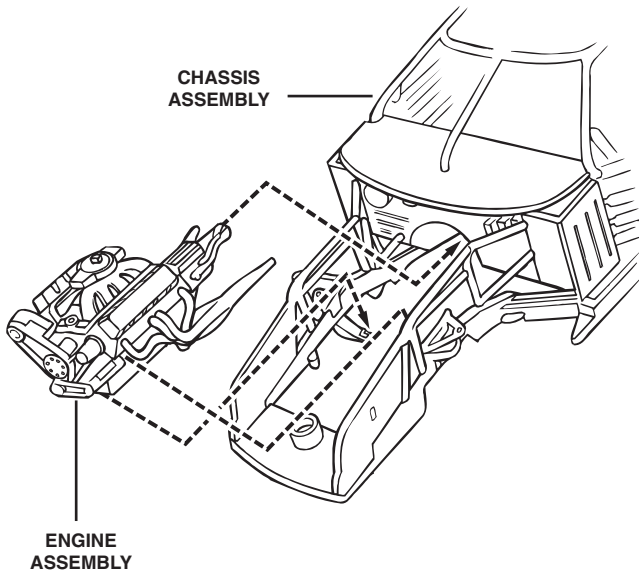

**B**

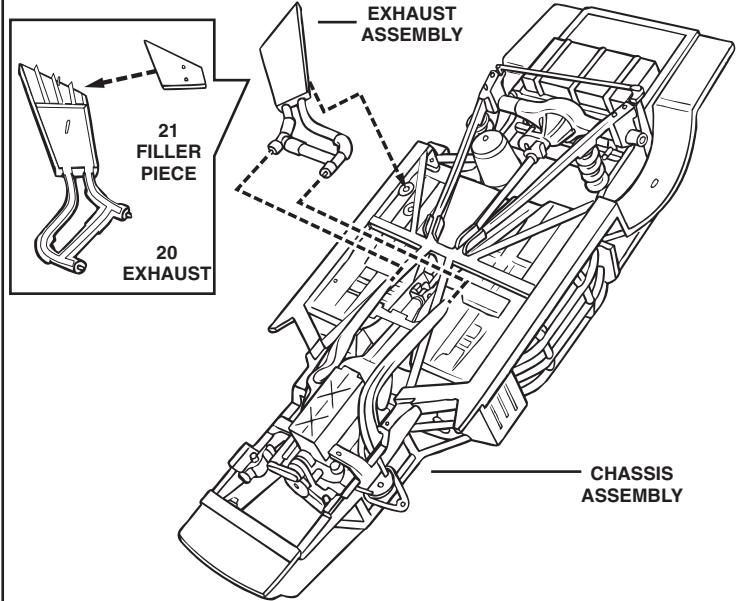

# 5

# FRONT END ASSEMBLY

**A**

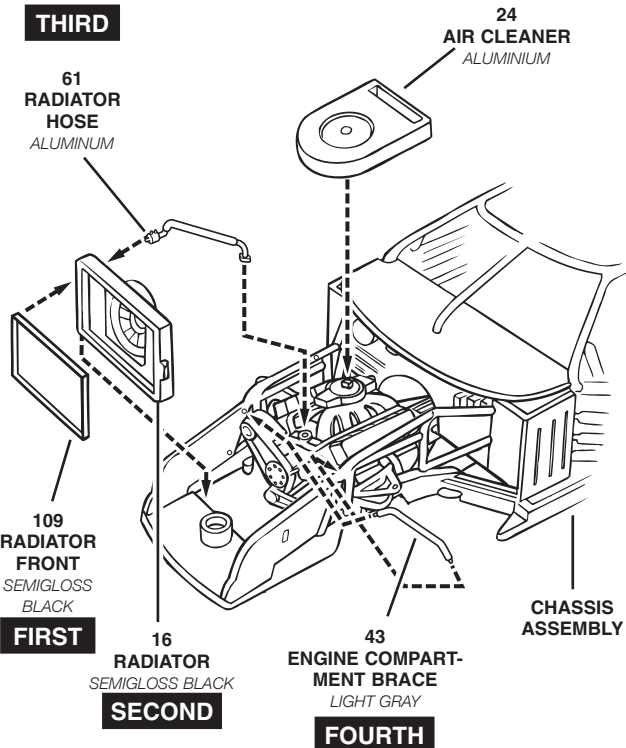

**B**

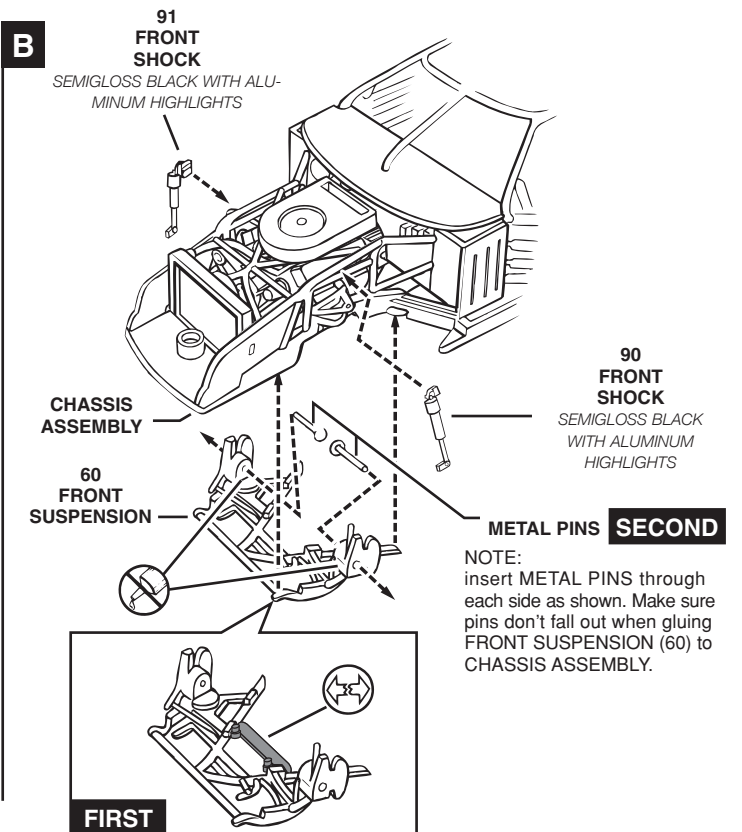

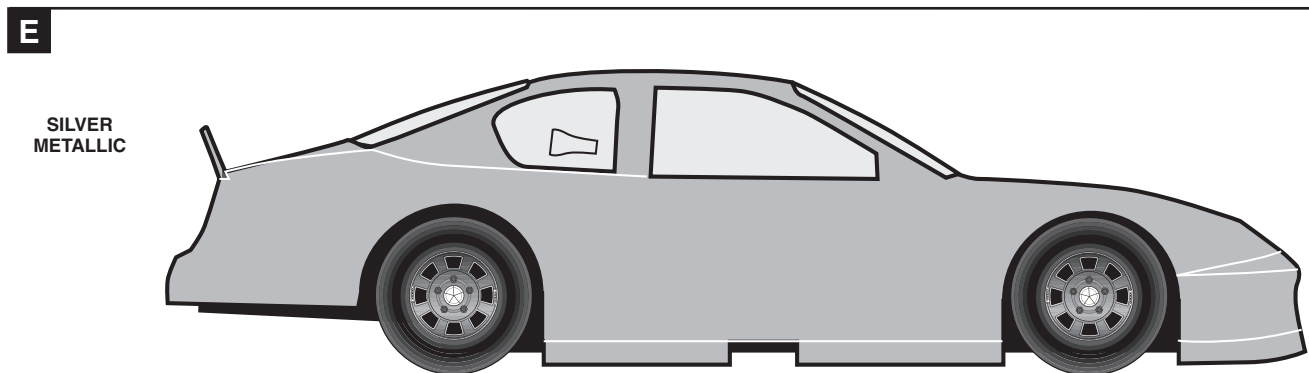
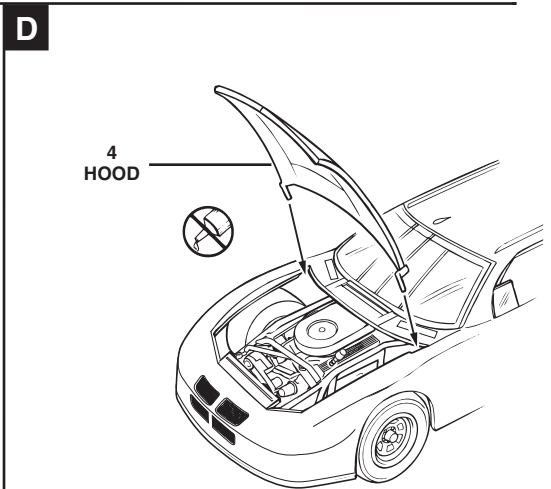
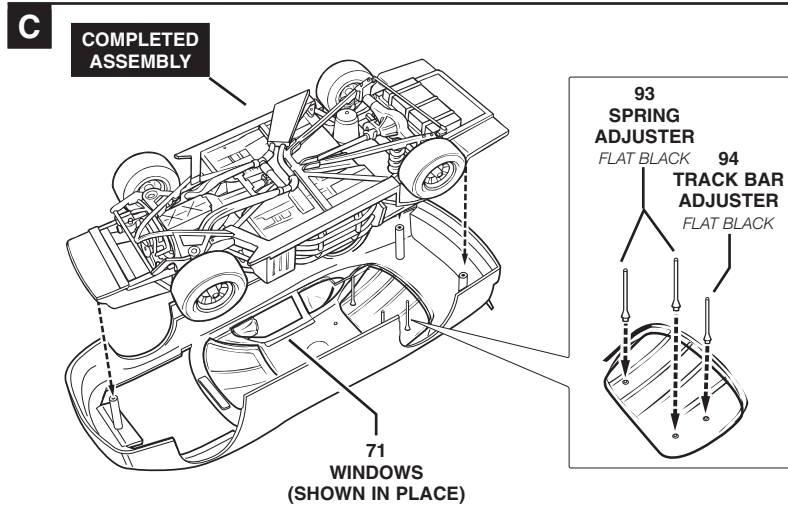
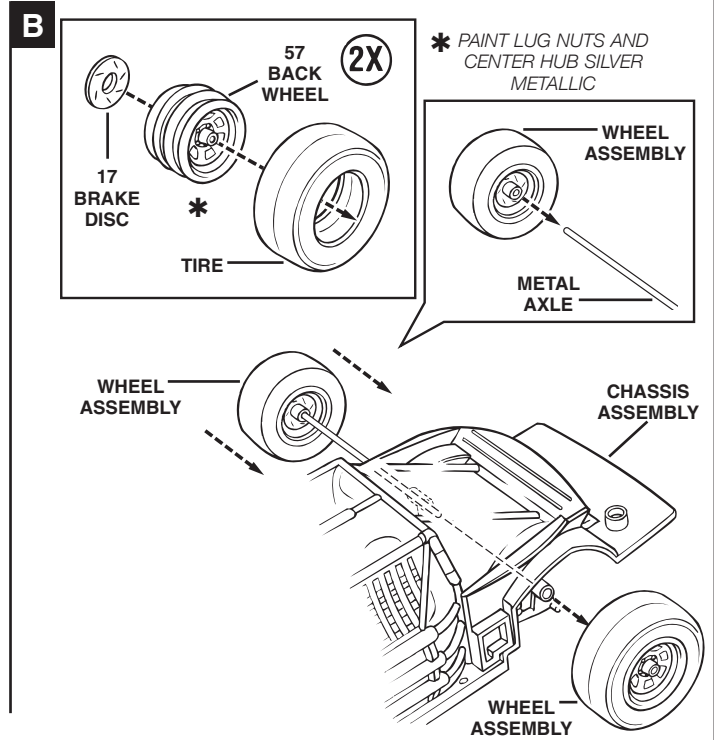
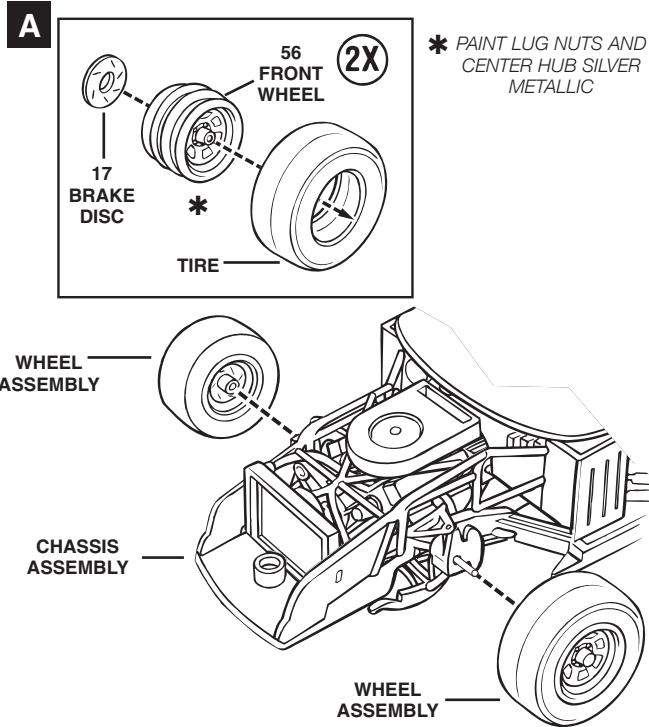

**NOTE: PAINTING TIP ON HOW TO PAINT BODY BEFORE DECAL PLACEMENT**



NOTE: DECALS 1, 5, 6, 7, 8, 19, 20, 39, and 40 MUST BE APPLIED FIRST

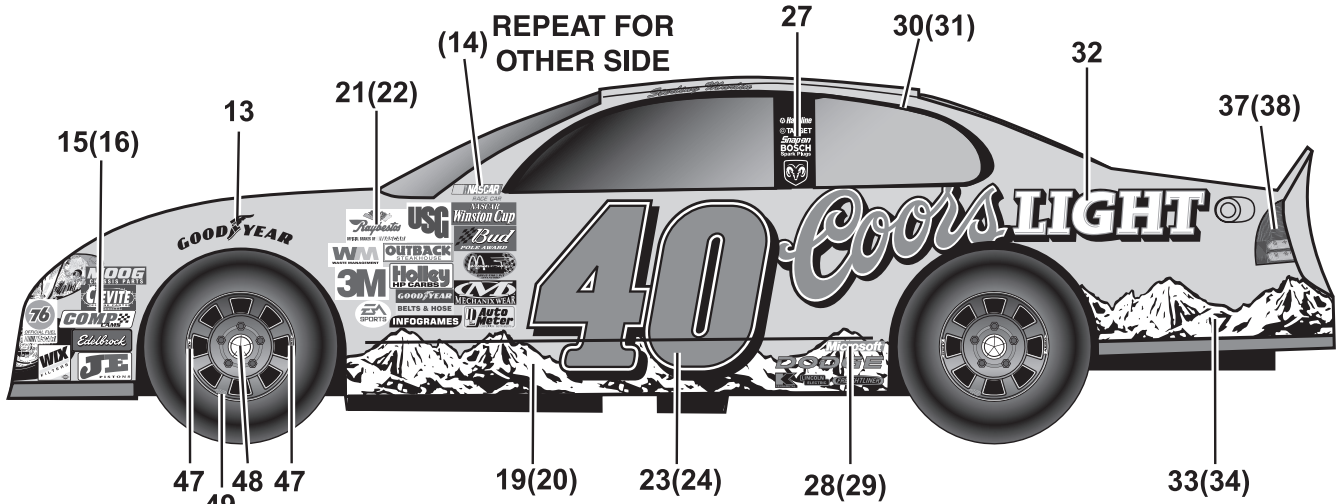

SAME FOR ALL WHEELS

