

Revell

KIT 2076

85207600200

'64 FORD FAIRLANE STREET MACHINE 2' N 1

The lightweight 1964 Ford Fairlane had unique unit body construction, which was ideal for drag racing applications. With the powerful 427 cubic-inch big block engine these cars captured many records and brought home countless trophies at drag strips all across the nation.

Your Revell model has a highly detailed high performance 427 V-8 racing engine, optional factory stock wheels with "dog dish" hub caps plus two sets of custom wheels, a detailed interior and chassis to build either a stock muscle car or vintage drag racer. Authentic water slide decal markings for both factory stock and vintage racing versions are also included.



Ford Oval and nameplates are registered trademarks owned and licensed by Ford Motor Company. Manufactured by Revell Inc.



* REPEAT SEVERAL TIMES
* A REPETER PLUSIEURS FOIS



* OPTIONAL PARTS
* PIECES EN OPTION



* DECAL
* DECAL COMANIE



* ALTERNATIVE ASSEMBLY
* ENSEMBLAGE ALTERNATIVE



* CEMENT TOGETHER
* A COLLER



* REMOVE AND THROW AWAY
* A RETIRER ET JETER



* DO NOT CEMENT
* NE PAS COLLER

READ THIS BEFORE YOU BEGIN

- * Study the assembly drawings.
- * Each plastic part is identified by a number.
- * In the assembly drawings, some parts will be marked by a star (★) to indicate chrome plated plastic.
- * For better paint and decal adhesion, wash the plastic parts in a mild detergent solution. Rinse and let air dry.
- * Check the fit of each piece before cementing in place.
- * Use only cement for polystyrene plastic.
- * Scrape plating and paint from areas to be cemented.
- * Allow paint to dry thoroughly before handling parts.
- * Any unused parts may be discarded.

DECAL APPLICATION INSTRUCTIONS

1. Cut desired decal from sheet.
2. Dip decal in water for a few seconds.
3. Place wet decal on paper towel.
4. Wait until decal is movable on paper backing.
5. Place decal in position on model, face up and slide backing away.
6. Press out air bubbles with a soft damp cloth.
7. Milkiness that may appear is for better decal adhesion and will dry clear. Wipe away any excess adhesive.
8. Do not touch decal until fully dry.
9. Allow the decals 48 hours to dry before applying clear coat.

NOTE: Decals are compatible with setting solutions or solvents.

LIRE CE QUI SUIT AVANT DE COMMENCER

- * Etudier les schémas de montage.
- * Chaque pièce en plastique est identifiée par un numéro.
- * Sur les schémas de montage, certaines pièces sont marquées d'une étoile (★) pour indiquer qu'elles sont en plastique chromé.
- * Pour une meilleure prise de la peinture et des autocollants, laver les pièces en plastique avec une solution détergente peu concentrée. Les rincer et les laisser sécher à l'air.
- * Vérifier que chaque pièce s'ajuste bien avant de la coller en place.
- * N'utiliser que de la colle pour polystyrène.
- * Gratter les parties à coller pour enlever le chrome et la peinture.
- * Laisser la peinture bien sécher avant de manipuler les pièces.
- * Toute pièce inutilisée peut être jetée.

DIRECTIVES D'APPLICATION DES AUTOCOLLANTS

1. Découper l'autocollant désiré de la feuille.
2. Tremper l'autocollant dans de l'eau pendant quelques secondes.
3. Placer l'autocollant mouillé sur une serviette en papier.
4. Attendez que l'autocollant puisse être déplacé sur son support en papier.
5. Mettre l'autocollant en position sur le modèle face sur le dessus et faire glisser le support pour l'enlever.
6. Appuyer avec un chiffon doux humide pour éliminer les bulles d'air.
7. La substance laiteuse qui peut apparaître est destinée à améliorer l'adhésion de l'autocollant et devient incolore au séchage. Essuyer pour enlever tout excédent d'adhésif.
8. Ne pas toucher l'autocollant tant qu'il n'est pas bien sec.
9. Laisser l'autocollant sécher pendant 48 heures avant d'appliquer une couche transparente.

REMARQUE: Les autocollants sont compatibles avec les solutions de fixation ou les solvants.

This paint guide is provided to complete this kit as shown on the box.

Ce guide de peintures est fourni pour reproduire le modèle réduit qui apparaît sur la boîte.

| | |
|-------------------|----------------|
| Aluminum | Aluminium |
| Silver | Argent |
| Semi Gloss Black | Noir satiné |
| Flat Black | Noir mat |
| Gloss Black | Noir brillant |
| Gloss Red | Rouge brillant |
| Steel | Acier |
| Flat Red | Rouge mat |
| Blue Metallic | Bleu métallisé |
| Turn Signal Amber | Ambre |

If you have any questions or comments, call our hotline at: **(800) 833-3570**
or, please write to:

Revell Inc Consumer Service Department, 1850 Howard Street Unit A, Elk Grove Village, Illinois 60007

Be sure to include the plan number (85207600200), part number, description, your return address and phone number.

Visit our website: www.revell.com

1

ENGINE ASSEMBLY

A MANUAL TRANSMISSION

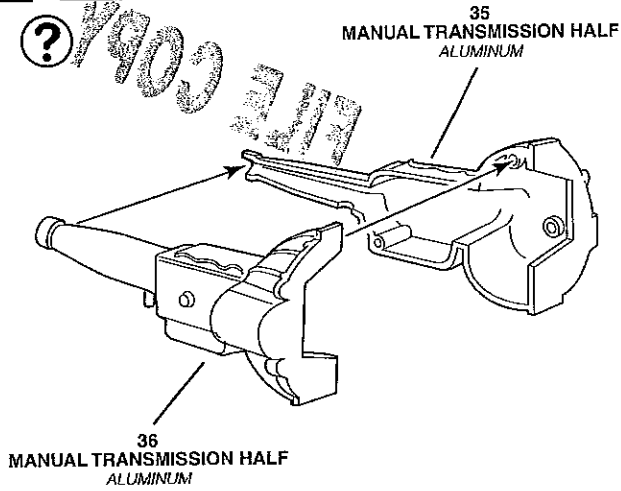

A AUTOMATIC TRANSMISSION

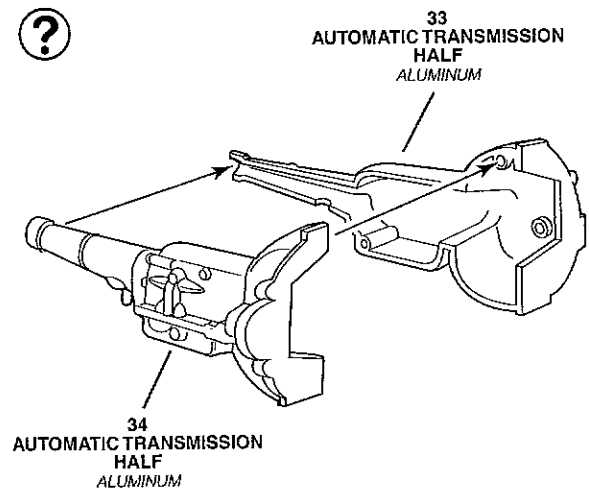

B

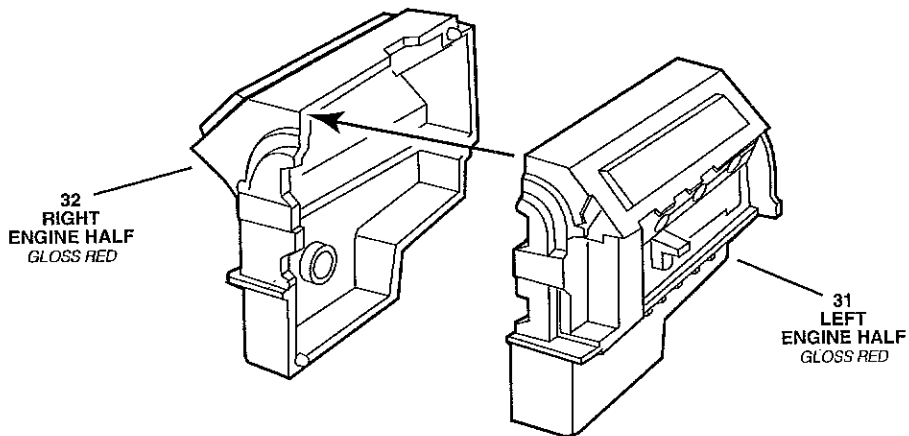

C

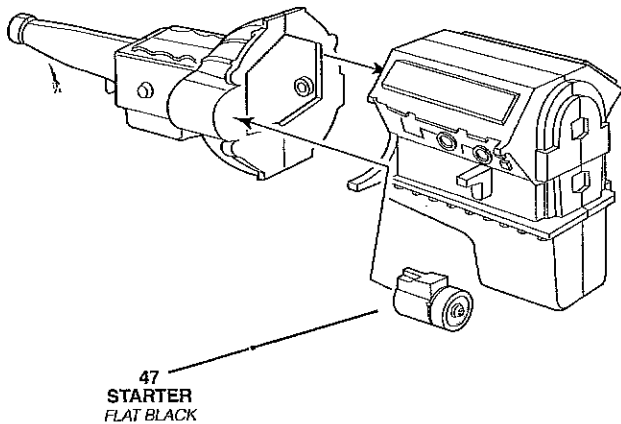

C

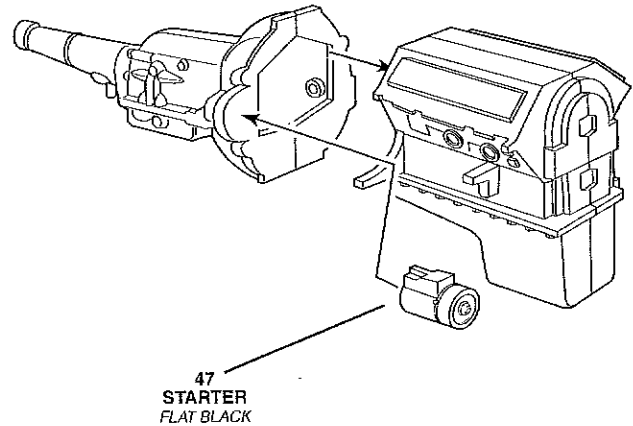

1

ENGINE ASSEMBLY CONTINUED

A

SECOND

★17
ROCKER COVER
CHROME

37
CYLINDER
HEAD
GLOSS RED

FIRST

★20
INTAKE MANIFOLD
CHROME

37
CYLINDER
HEAD
GLOSS RED

★17
ROCKER COVER
CHROME

SECOND

B

39
OIL FILLER
SILVER

40
DISTRIBUTOR
SEMI GLOSS BLACK

★18
CARBURETOR
CHROME

C

SILVER
FLAT BLACK

38
HEADER TANK
GLOSS RED

45
WATER PUMP
GLOSS RED

FLAT BLACK

SEMI GLOSS BLACK
ALUMINUM

46
OIL FILTER COIL

GLOSS WHITE

D

★22
ALTERNATOR
CHROME

★21
FAN
CHROME

FLAT BLACK

41
FAN BELT
SILVER

E

COMPLETED ENGINE ASSEMBLY

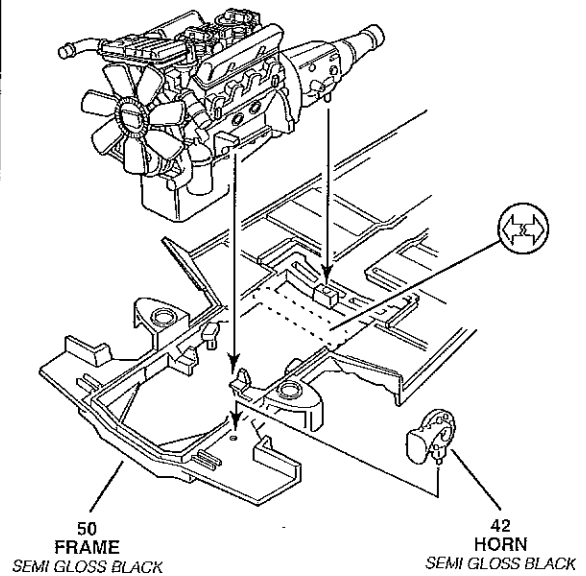

2

STABILIZER BAR ASSEMBLY

48
STABILIZER BAR
SEMI GLOSS BLACK

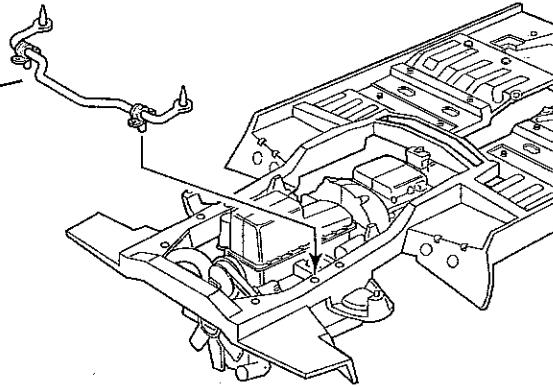

3

HEADER ASSEMBLY

62
RIGHT
OUTBOARD HEADER
STEEL

61
RIGHT
INBOARD HEADER
STEEL

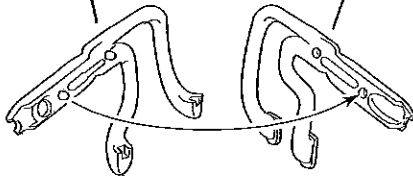

59
LEFT
INBOARD HEADER
STEEL

60
LEFT
OUTBOARD HEADER
STEEL

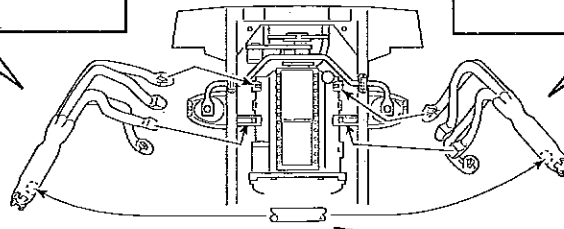
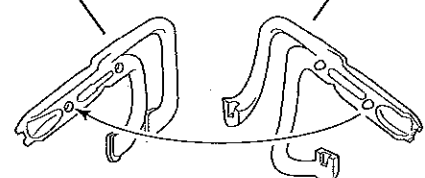

68
CROSS OVER PIPE
STEEL

4

FRONT SUSPENSION ASSEMBLY

51
FRONT SUSPENSION
SEMI GLOSS BLACK

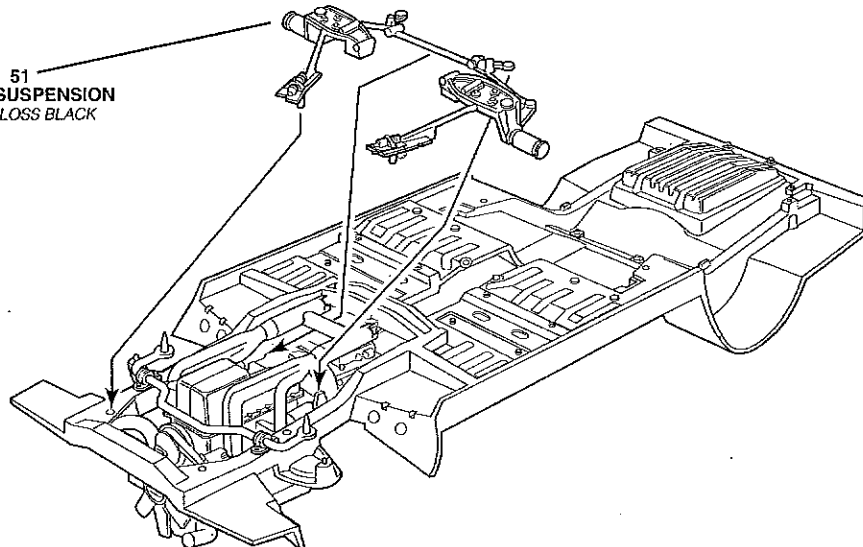

5

EXHAUST / CHASSIS ASSEMBLY



**STREET MACHINE
VERSION**

104
LEFT
SIDE EXHAUST PIPE
STEEL

105
RIGHT
SIDE EXHAUST PIPE
STEEL

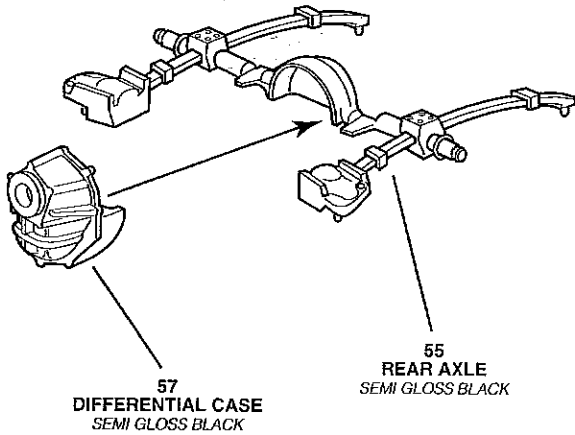
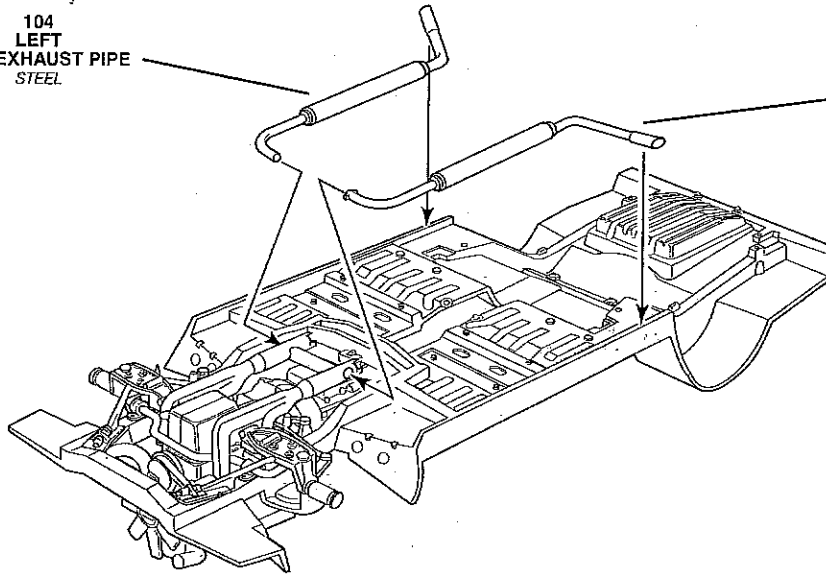

58
DRIVESHAFT
SEMI GLOSS BLACK

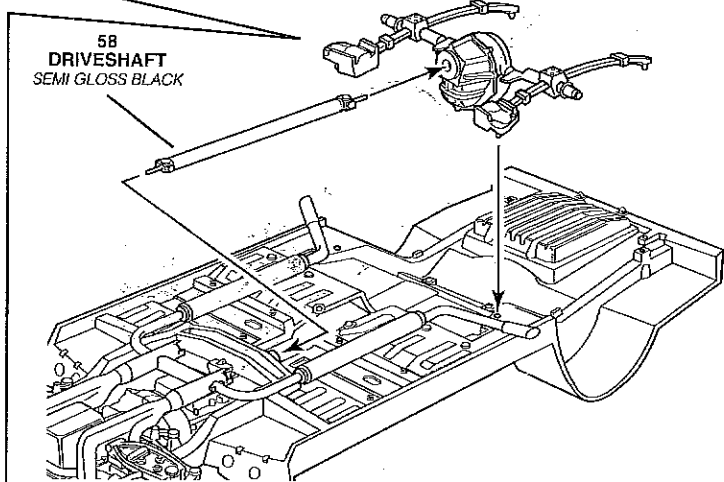

56
COIL SPRINGS
SEMI GLOSS BLACK

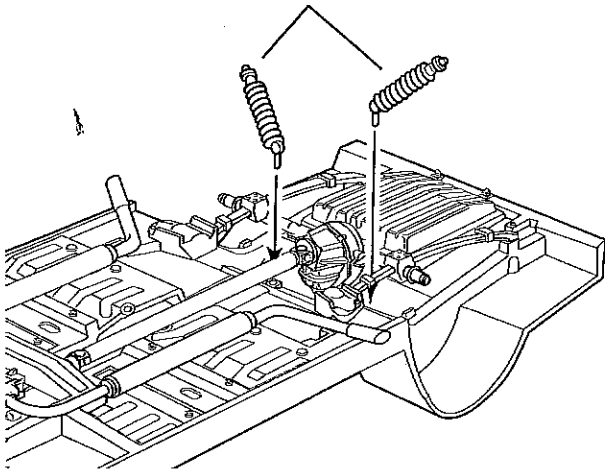

54
REAR CROSSMEMBER
SEMI GLOSS BLACK

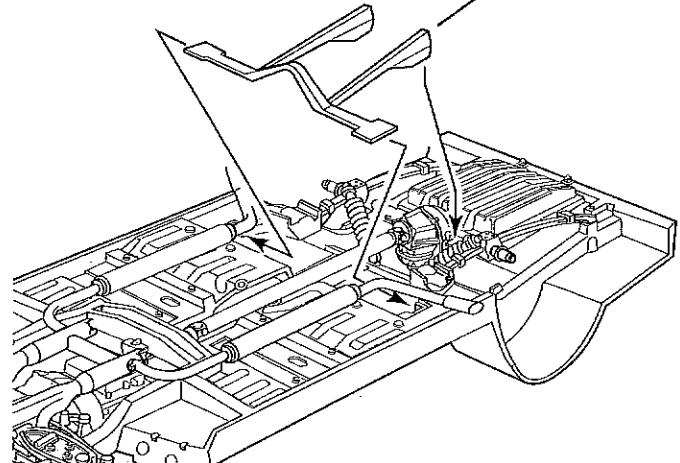

WHEEL ASSEMBLY

FRONT

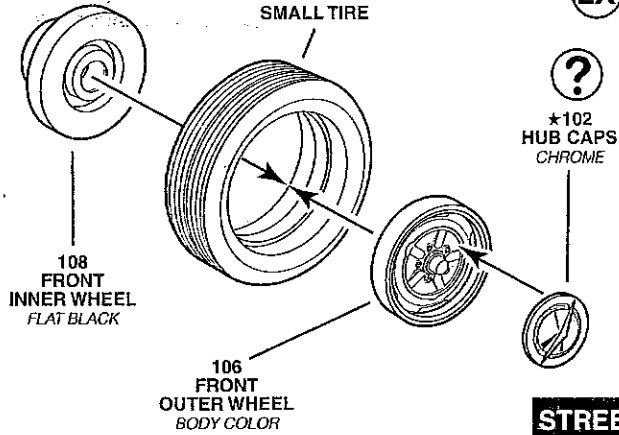

REAR

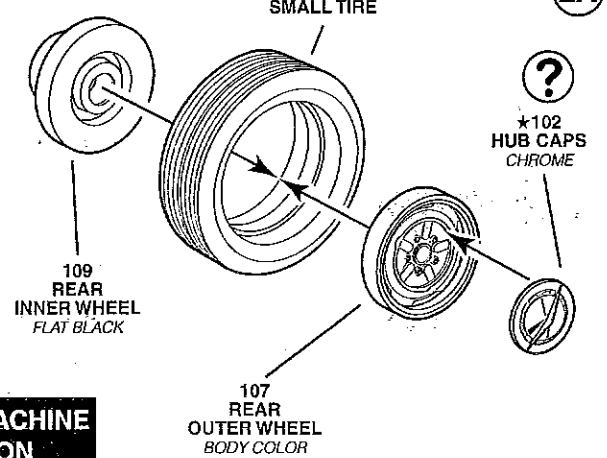

STREET MACHINE VERSION

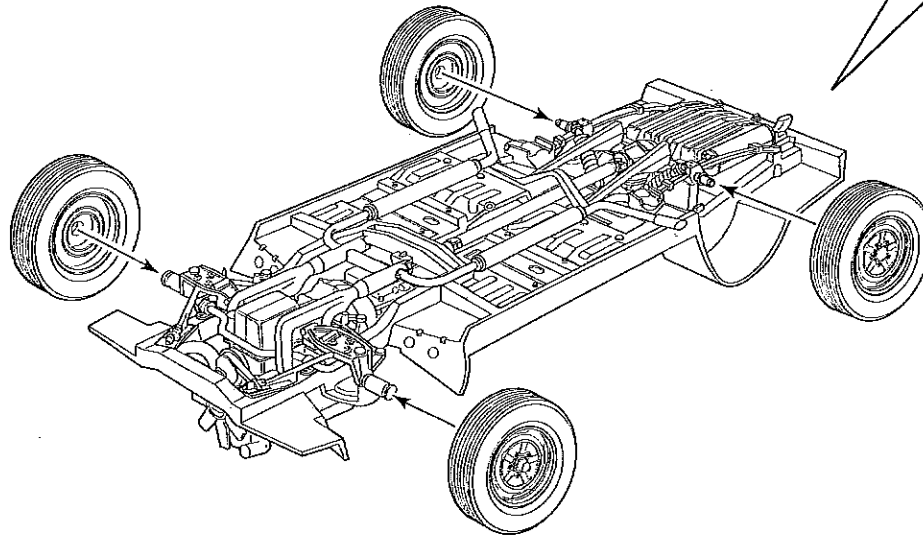

FRONT

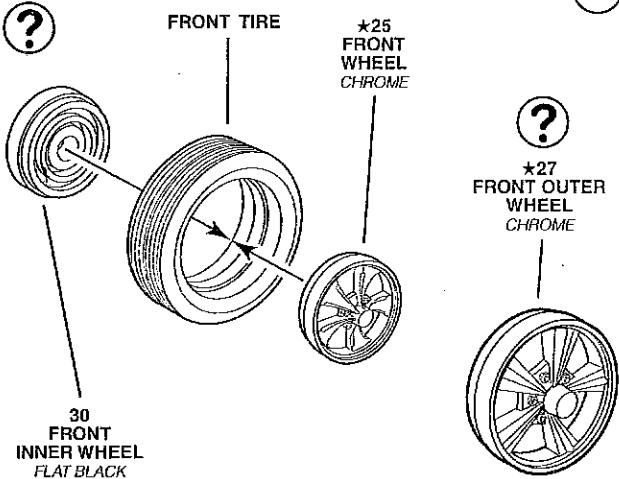

REAR

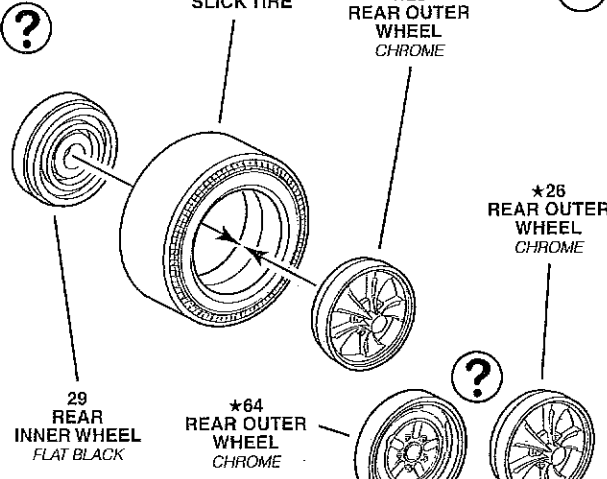

RACE VERSION

7

DASHBOARD / INTERIOR ASSEMBLY

MANUAL TRANSMISSION

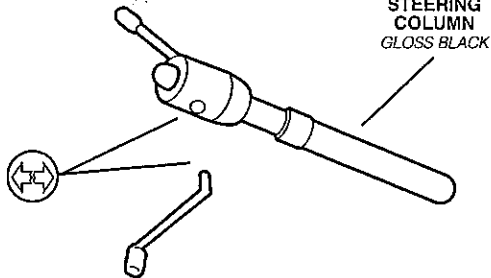

AUTOMATIC TRANSMISSION

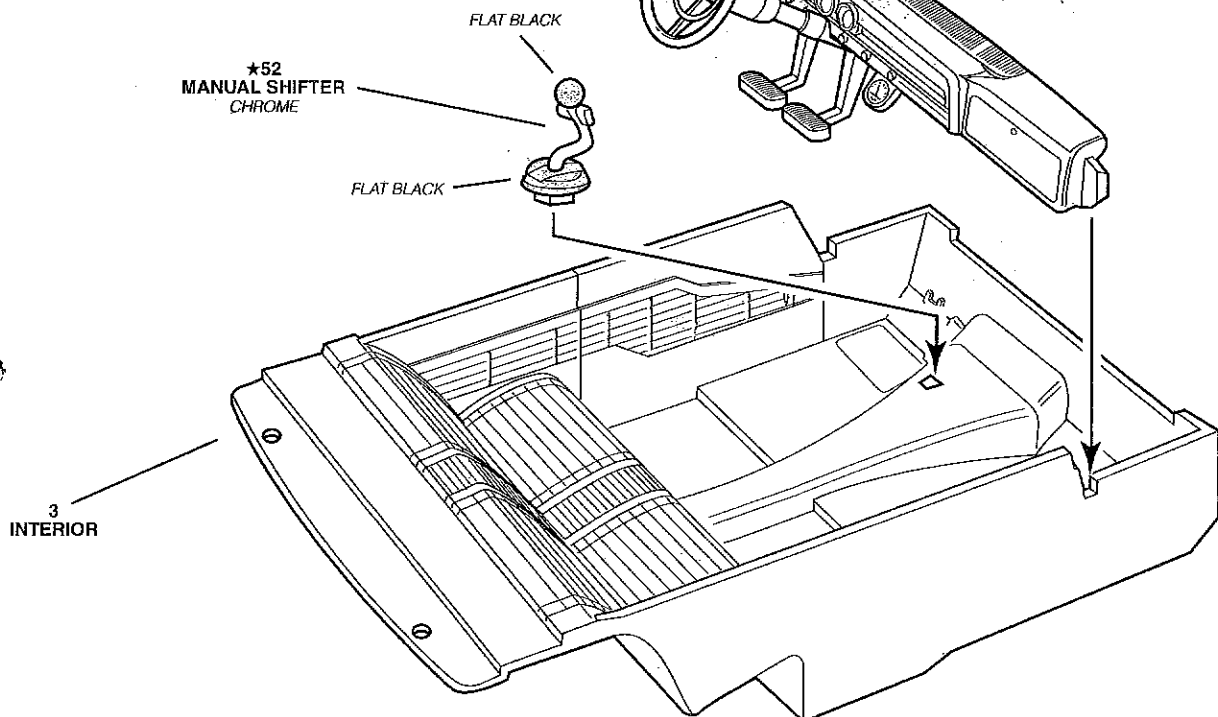
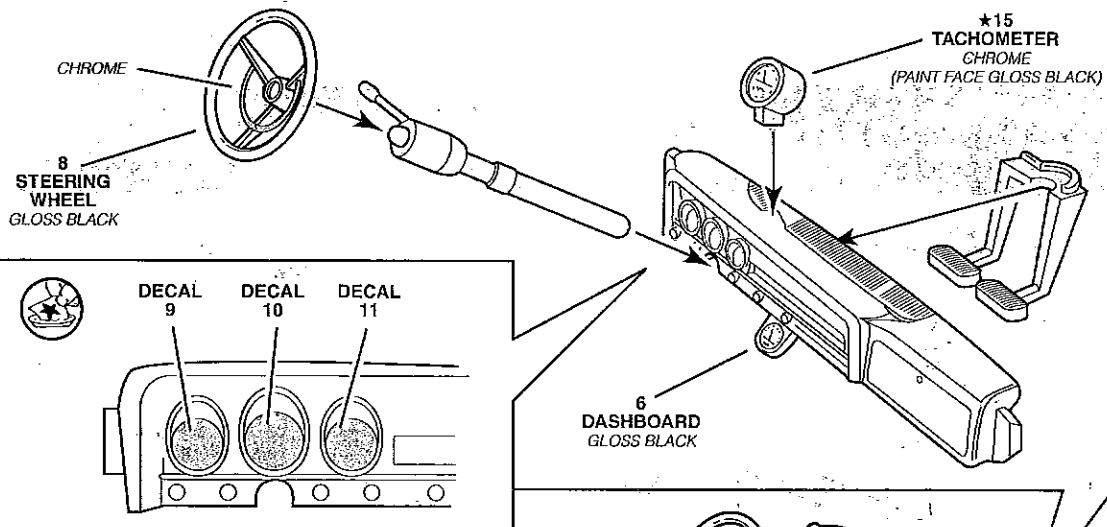
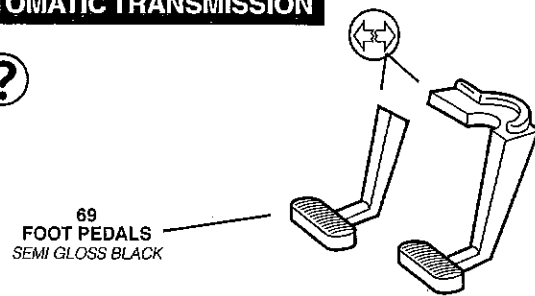

8

SEAT ASSEMBLY

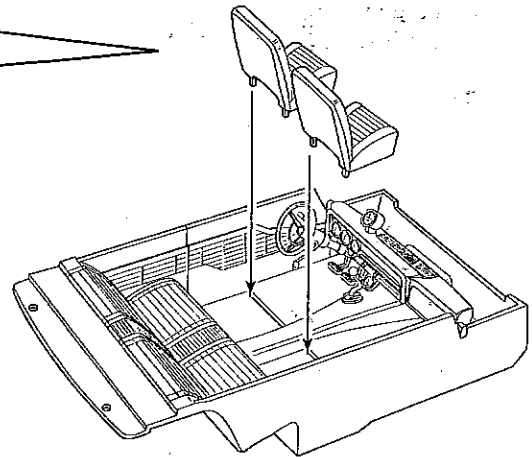
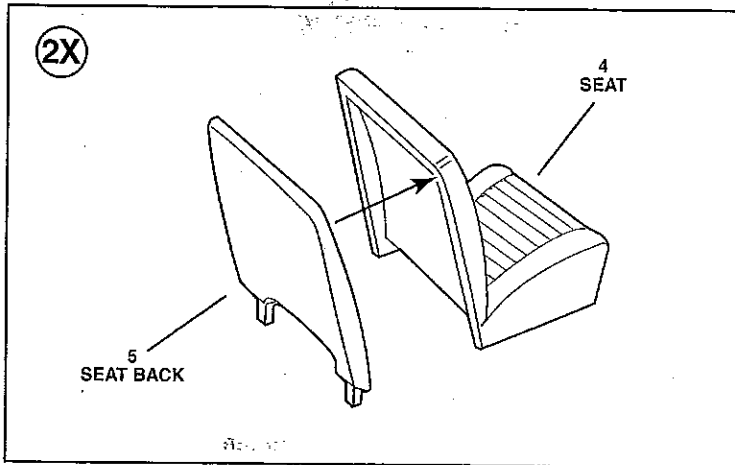

9

WINDOW ASSEMBLY

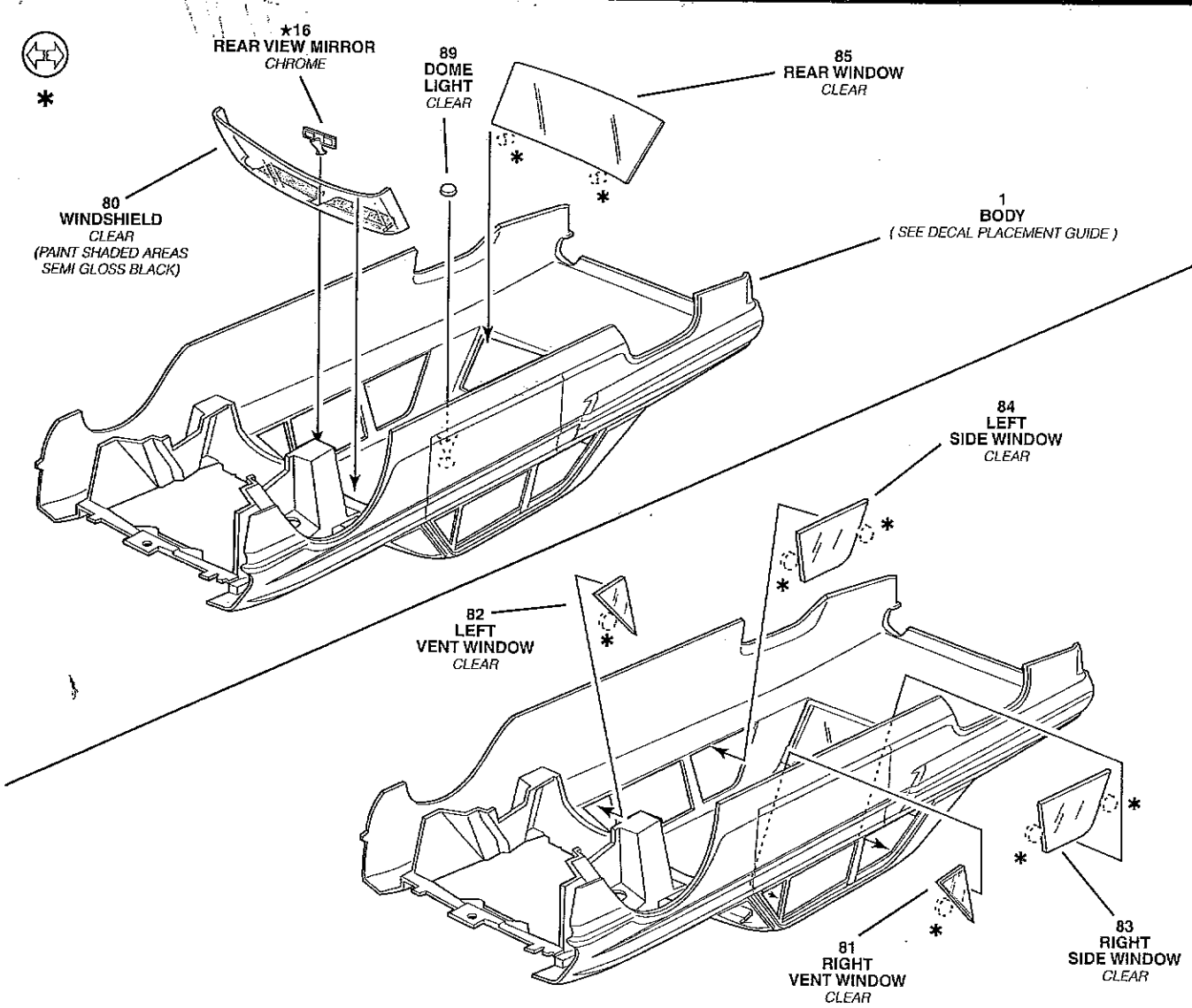

10

BODY / CHASSIS ASSEMBLY

INTERIOR TO BODY

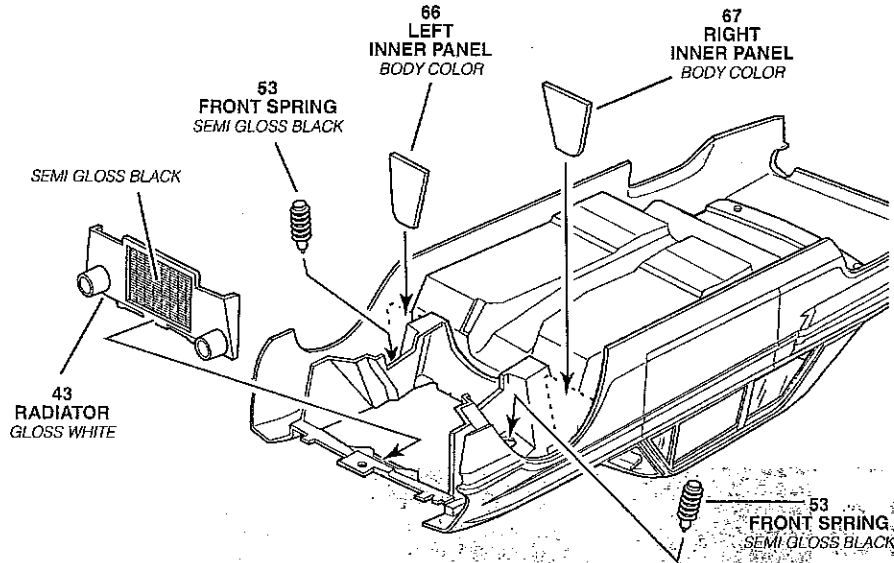
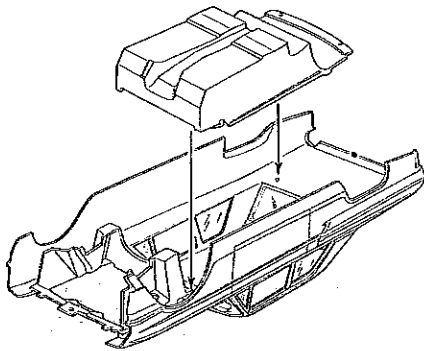

**CHASSIS TO BODY.
WHEEL OMITTED FOR
CLAIRTY**

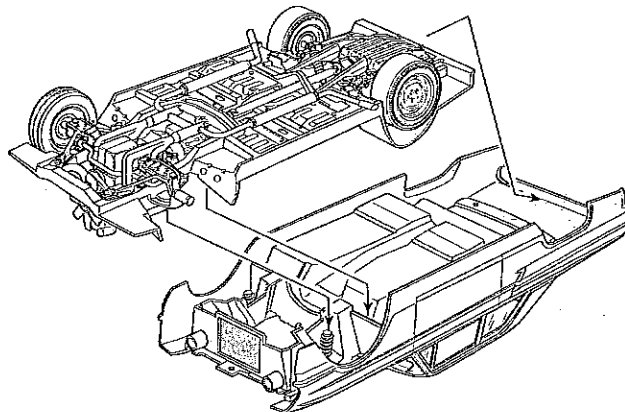

11

GRILLE ASSEMBLY

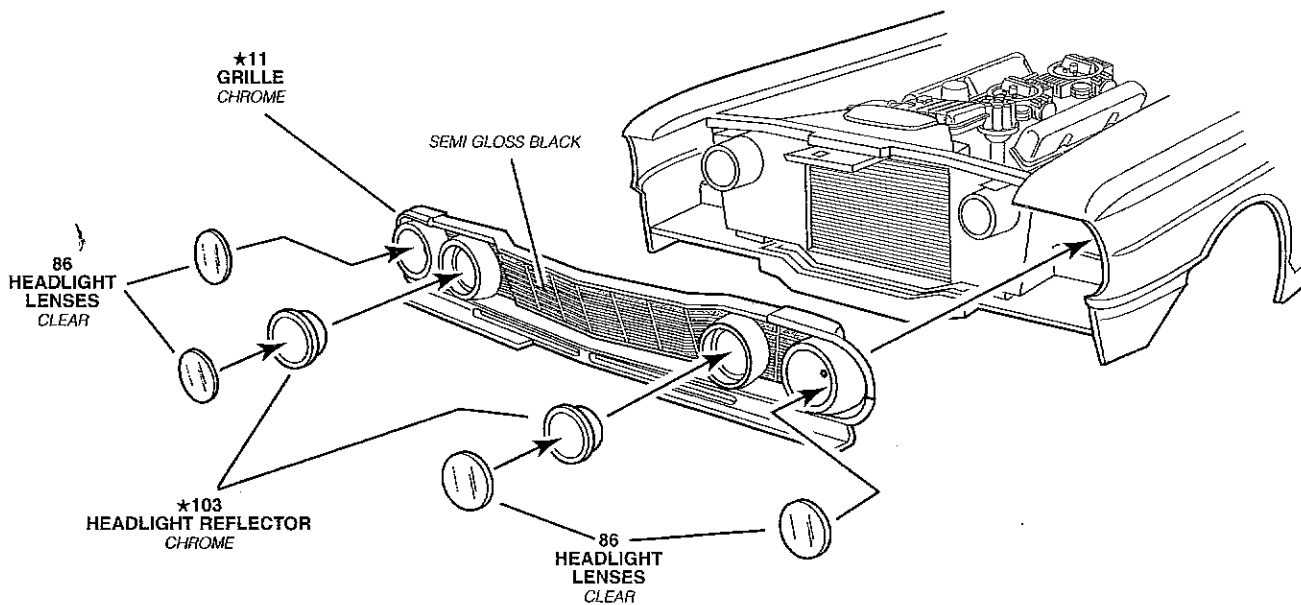

12

BUMPER ASSEMBLY

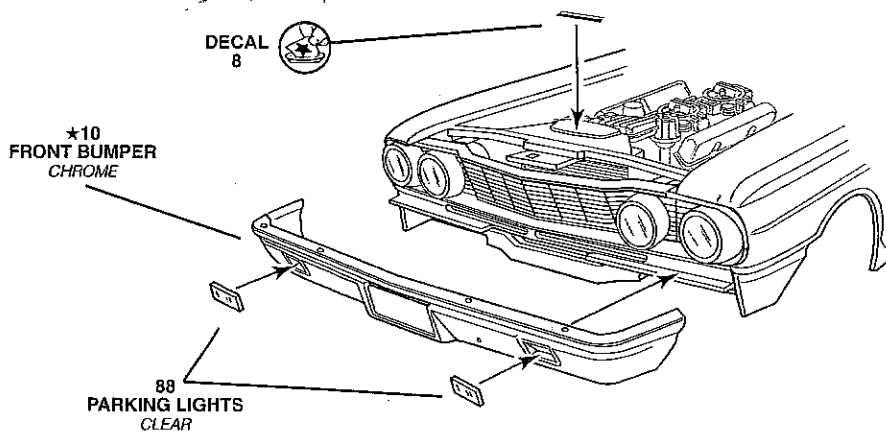

13

REAR ASSEMBLY

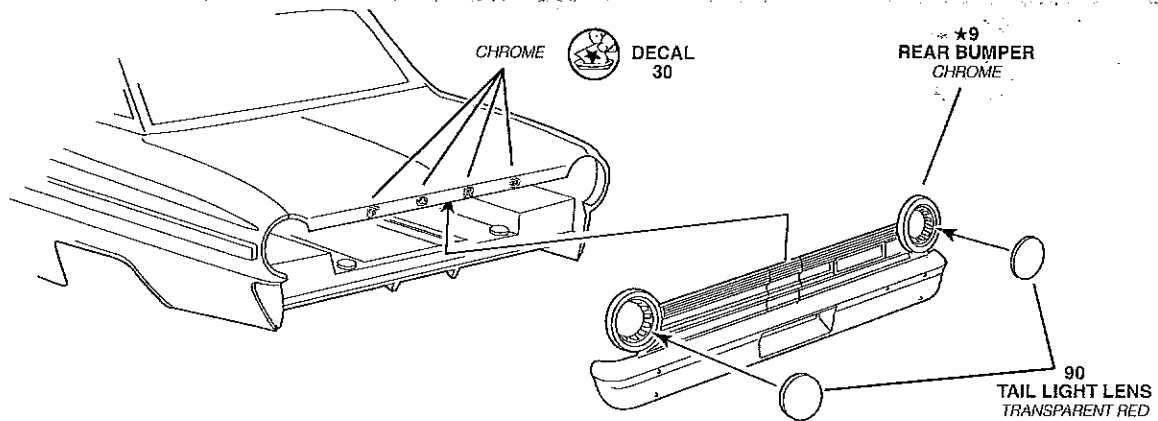

14

ENGINE COMPARTMENT ASSEMBLY

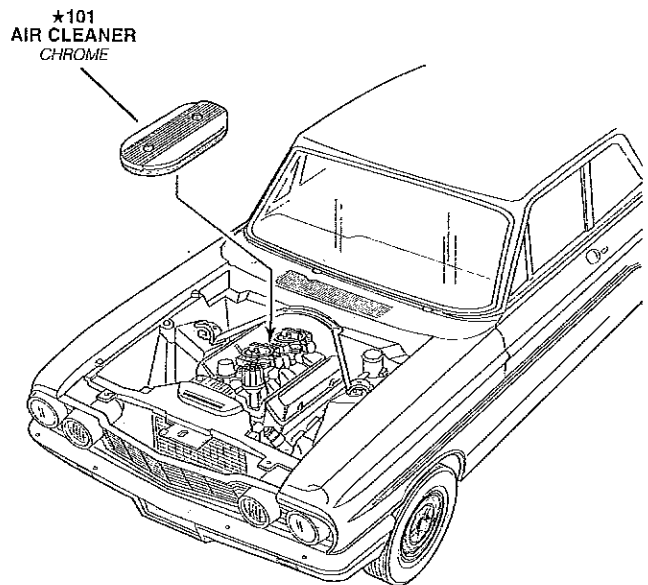
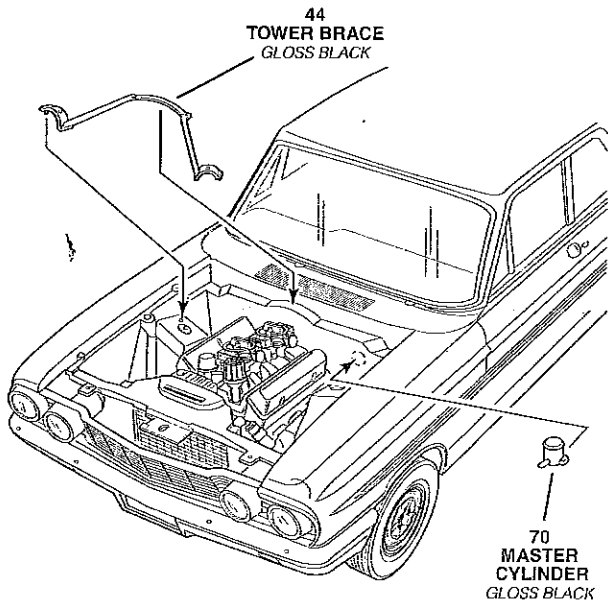

15

WIPER / DOOR HANDLE ASSEMBLY

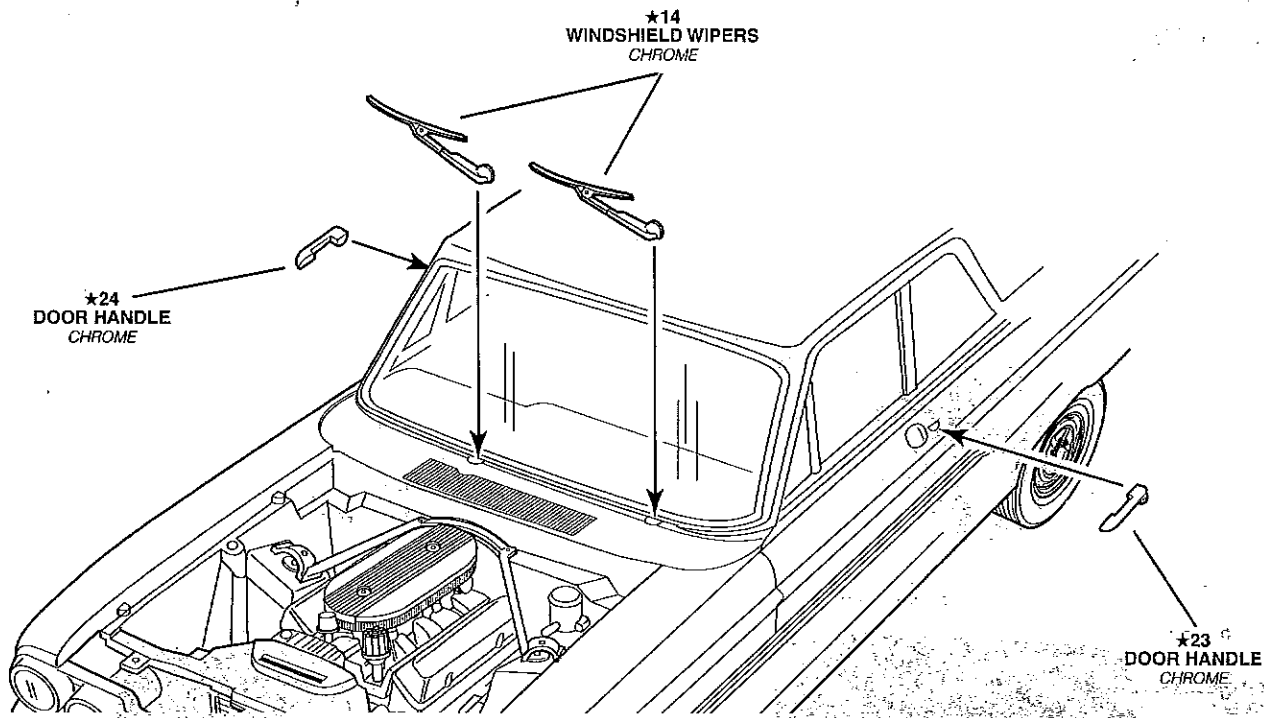

16

HOOD ASSEMBLY

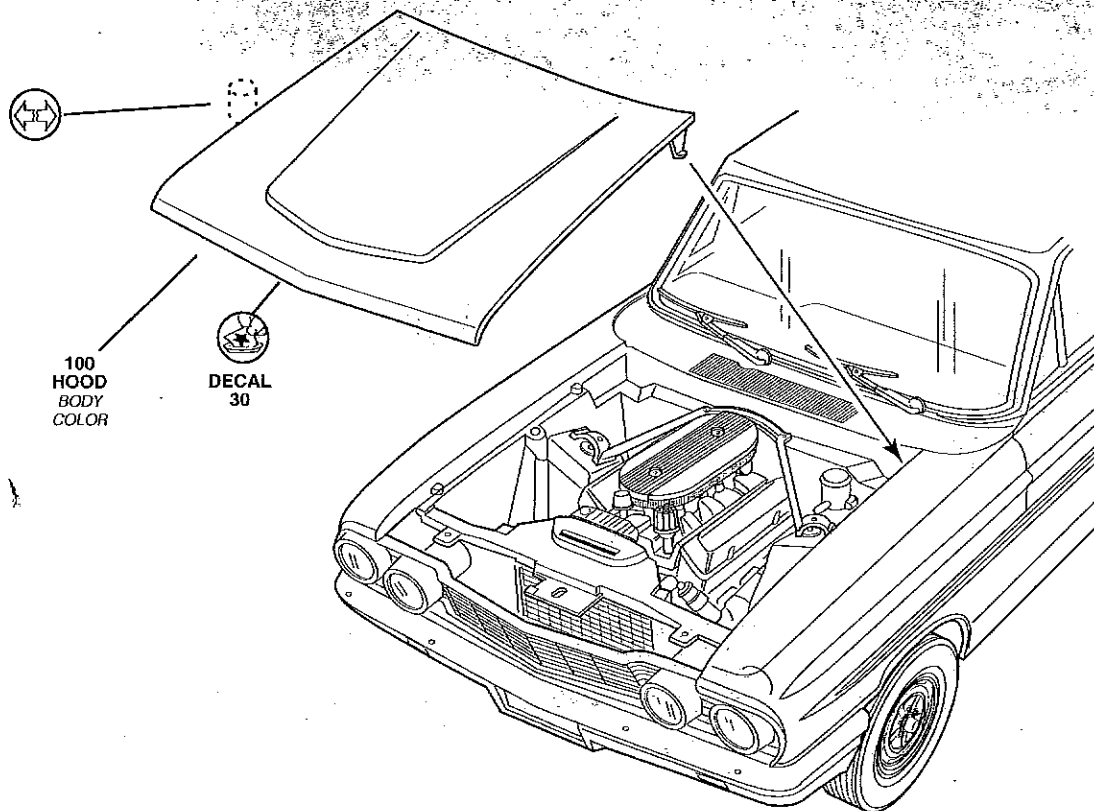

DECAL PLACEMENT

Version A

* Repeat for other side

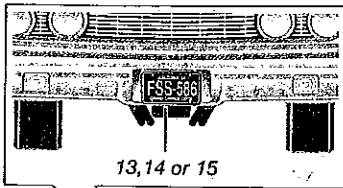

28
Red, Black or White
(Repeat for other side using 31)

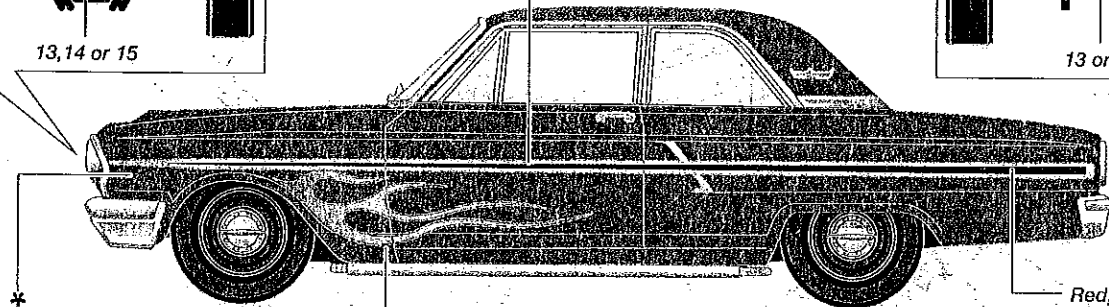
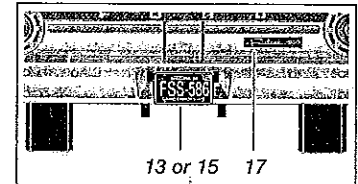

(Repeat for other side using 7)

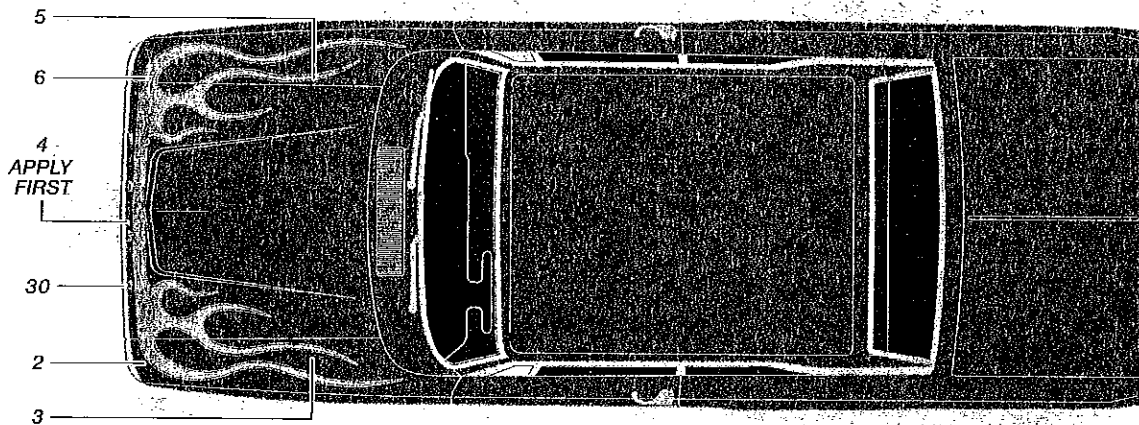

Version B

* Repeat for other side

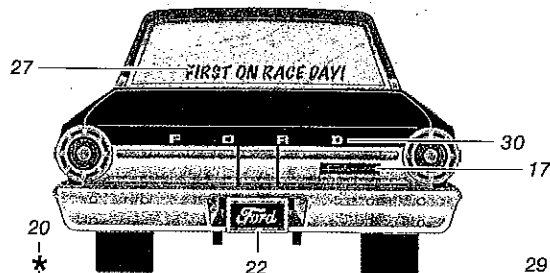
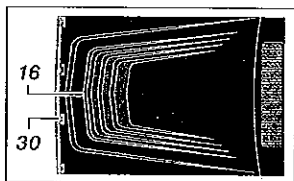

28
Red, Black or White
(Repeat for other side using 31)

29
Red, Black or White
(Repeat for other side using 32)

