

# U.S.S. IOWA

## READ THIS BEFORE YOU BEGIN

- Study the assembly drawings.
- Each plastic part is identified by a number.
- Model may be painted to match photos on box.
- Allow paint to dry thoroughly before handling parts.
- For better paint and decal adhesion, wash the plastic parts in a mild detergent solution. Rinse and let air dry.

## ALLGEMEINE HINWEISE

- Die Anordnung der Bauteile ist aus den Zeichnungen der Anleitung ersichtlich.
- Jedes Plastikteil ist durch eine Nummer gekennzeichnet.
- Man kann das Modell nach den Fotos auf der Schachtel anstreichen.
- Bemalte Teile vor der Weiterverwendung gut trocknen lassen.
- Damit die Farbe und die Abziehbilder besser kleben, sind die Plastikteile in einer milden Seifenlauge zu waschen. Dann abspülen und an der Luft trocknen lassen.

## LEA ESTO ANTES DE EMPEZAR

- Estudie los dibujos de en ensamble.
- Cada pieza de plástico se identifica por un número.
- El modelo puede pintarse de acuerdo con las fotografías de la caja.
- Permita que se seque la pintura completamente antes de tocar las piezas.
- Para una mejor fijación de la pintura y de las calcomanías, lávase las piezas plásticas en una solución de detergente suave. Enjuáguese y déjense secar al aire.

## LEES DIT ALVOREN TE BEGINNEN

- Bestudeer de bouwtekening.
- Elk plastic onderdeel is genummerd.
- Men kan model verven zoals aangeduid op de doos.

- Laat de verf van de te verwerken delen steeds goed drogen.
- Zodat de verf en etiketten beter zullen plakken, was de plasticke delen in een milde seep oplossing. Spoel een laai in de openlucht opdrogen.

## LISEZ CE QUI SUIT AVANT DE COMMENCER LE MONTAGE

- Étudiez les schémas d'assemblage.
- Chaque pièce plastique porte de numéro d'identification.
- Le modèle peut être peint conformément aux photos sur la boîte.
- Laissez sécher la peinture complètement, avant de manipuler les pièces.
- Pour assurer la meilleure adhésion possible de la peinture et des décalcomanies, lavez les pièces de plastique avec une légère solution savonneuse. Rincez et laissez sécher à l'air.

## LAS DET HAR INNAN DU BORJAR BYGGGA

- Studera monteringskisserna.
- Alla plastdelar har identifikationsnummer.
- Modellen kan målas enligt fotona på kantzonen.
- Låt färgen torka ordentligt före limningen.
- För bättre vidhäftning av färg och dekalmarken rengör plastdelarna i en mild tvättmedelslösning. Skölj och låt lufttorka.

## DA LEGGERE PRIMA DI INIZIARE

- Studia le illustrazioni.
- Ogni pezzo è identificato da un numero.
- Il modello si può dipingere seguendo la fotografia sulla scatola.
- Aspetta che la vernice sia completamente asciutta prima di maneggiare le parti.
- Per una migliore sderenza di vernice e decalcomanie, lavare le parti in soluzione detergente non abrasiva. Risciacquare e lasciar asciugare all'aria.

A	FLAT BLACK	GLANZLOSES SCHWARZ	NEGRO APAGADO	GLANSLOOS ZWART	NOIR TERNE	MATTSVART	NERO OPACO
B	BLUE	BLAU	AZUL	BLAUW	BLEU	BLÅ	BLU
C	GLOSS BLACK	GLANZENDES SCHWARZ	NEGRO BRILLANTE	GLANZEND ZWART	NOIR LUSTRE	BLANK SVART	NERO BRILLANTE
D	RED	ROT	ROJO	ROOD	ROUGE	ROD	ROSSO
E	GOLD	GOLD	DORADO	GOUD	DORE	GULDFÄRG	ORO
F	LIGHT BROWN	HELLBRAUN	MARRON CLARO	LICHT BRUIN	MARRON CLAIR	LJUSBRUN	MARRONE CHIARO
G	DARK GRAY	DUNKELGRAU	GRIS OSCURO	DONKER GRIS	GRIS FONCE	MÖRKGRÅ	GRIGIO SCURO

Proud and powerful, the U.S.S. Iowa was the initial vessel in the class of "Iowa" battleships. The U.S.S. Iowa was constructed by the New York Navy Yard, and it was launched in August of 1942. Many historians consider this battleship class to be the most purposeful design ever created. The hull of this massive warship was fitted with armor that was nine to ten inches thick.

# U.S.S. IOWA



MODEL KIT 1732



7

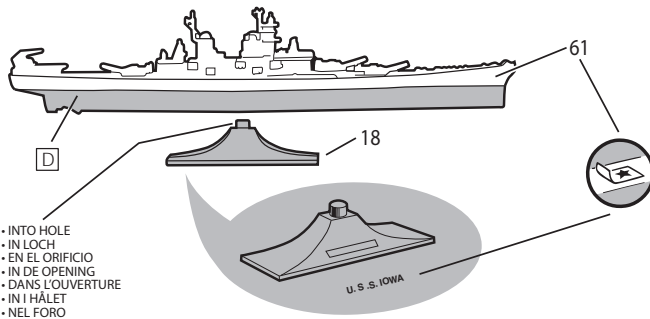
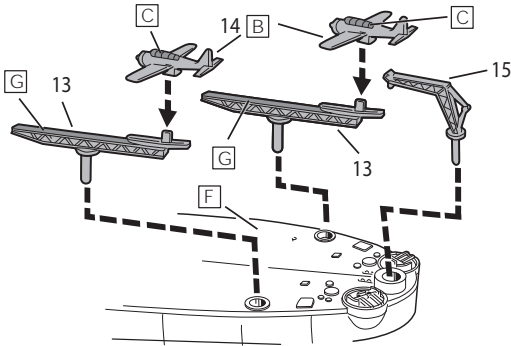

- INTO HOLE
- IN LOCH
- EN EL ORIFICIO
- IN DE OPENING
- DANS L'OUVERTURE
- IN I HÅLET
- NEL FORO

2X

REPEAT SEVERAL TIMES  
A REPETER PLUSIEURS FOIS



REMOVE AND THROW AWAY  
A RETIRER ET JETER



APPLY STICKERS  
APPLIQUEZ LES AUTO-COLLANTS

- THIS KIT MAY BE SNAPPED TOGETHER, BUT PARTS MAY BE CEMENTED IF YOU PREFER.
- DIE TEILE DIESES BAUSATZES WERDEN DURCH ZUSAMMENSTECKEN VERBUNDEN, KÖNNEN JEDOCH, FALLS GEWÜNSCHT, VERKLEBT WERDEN.
- ESTE KIT PUEDE SER ENSAMBLADO A PRESION.

- PERO LAS PIEZAS SE PUEDEN UNIR CON PEGAMENTO SI SE PREFERE.
- DEZE KIT KAN NAAR KEUSE MET OF ZONDER LIJM WORDEN GEMONTEERD.
- CETTE MAQUETTE S'ASSEMBLE PAR SIMPLE PRESSION, MAIS VOUS POUVEZ COLLER LES PIÈCES SI VOUS LE PREFEREZ.

- DENNA BYGGSSATS KAN SNÄPPAAS IHOP, MEN DELARNA KAN OCKSÅ LIMMAS IHOP OM SÅ FÖREDRAS.
- IL MONTAGGIO DEL CONTENUTO DI QUESTA SCATOLA PUÒ ESSERE EFFETTUATO CONGIUNGENDO LE PARTI A SCATTO A SCELTA, E POSSIBILE ANCHE INCOLLARLE.

1

