



KIT 1595

85159500200

Chevrolet® Small Block Street Rod Engine

2005 marks the 50th anniversary of the Chevrolet® overhead valve V8 engine affectionately known to millions of hot rod fans as the Small Block Chevy®. With over 90 million units produced to date in a myriad of different cubic inch displacement sizes and horsepower outputs, the Small Block Chevy® V8 has appeared in more vehicles (many of which were not originally produced by Chevrolet) than probably any other engine.

Development of the engine began in late 1952 and was headed by new Chevrolet chief engineer Ed Cole, who formerly held the same position at Cadillac® and directed the design of the V8 Cadillac introduced in 1949. When he arrived, Chevy engineers had a 231 cubic inch V8 in development. Partly due to the fact that with the size and weight of GM cars increasing and the expanding use of power accessories and air conditioning units that sapped more and more power from the car's engine, a larger displacement V8 was considered desirable for future plans and work on the 231 ceased.

Once the basic design for the new engine small block was down on paper, it took Cole's team of engineers only 15 weeks to go from the drawing board to running prototype status, a remarkably short period of time. Smaller and more compact in physical size than any V8 engine before it, the basic block weighed less than even the Chevy straight six cylinder engine it replaced while producing far more power and torque. It also could reach higher rpms reliably than other engines, hinting at the performance potential that engineers would eventually tap into.

Initially appearing in the redesigned 1955 Chevrolet, the first small block had 265 cubic inches of displacement and produced 162 horse-

power at 4400 rpm. The versatile little engine was bored, stroked and modified over the years to eventually grow to 400 cubic inches.

Probably the most widely remembered version was the 350 cubic inch V8, which powered everything from station wagons to pickup trucks to the Corvette®. Even the boxy Checker taxicab was powered by small block Chevy engines near the end of that company's run, the engine being chosen specifically for its durability and reliability.

In high-performance circles, mechanics, racers and hot rod builders still consider the Small Block Chevy to be the ideal powerplant for their projects. Its clean design, reliability and wide availability of aftermarket speed parts make it the rodder's #1 choice. A typical but by no means unique setup is the one you will be building during the construction of your new Revell Small Block street Rod engine.

Loaded with such go-fast goodies such as a high-performance intake manifold with a big four barrel carb, exhaust headers and modern electronic ignition system. Your new Revell 1:6 scale small block also features chrome valve covers, alternator and low-restriction air cleaner. Packed with so much detail, you can almost hear the rumble of its idle.

It'll look perfect displayed along side your other small block equipped models. While larger than your 1:24/1:25 scale models, it offers far greater detail than we could ever offer in the smaller scale. It will be a fitting tribute to what is arguably the most prolific engine series in modern American automotive history, the Small Block Chevrolet V8.



* REPEAT SEVERAL TIMES
* A REPETER PLUSIEURS FOIS



* CEMENT TOGETHER
* A COLLER



* DO NOT CEMENT
* NE PAS COLLER

If you have any questions or comments, call our hotline at: **(800) 833-3570**
or, please write to:

Revell-Monogram Consumer Service Department, 725 Landwehr Road, Northbrook, Illinois 60062

Be sure to include the plan number (85159500200), part number, description, your return address and phone number.

Visit our website: www.revellmonogram.com

1

BLOCK ASSEMBLY



MEDIUM COURSE



MEDIUM FINE



LONG FINE



SHORT COURSE



LONG COURSE



SHORT COURSE WITH WASHER

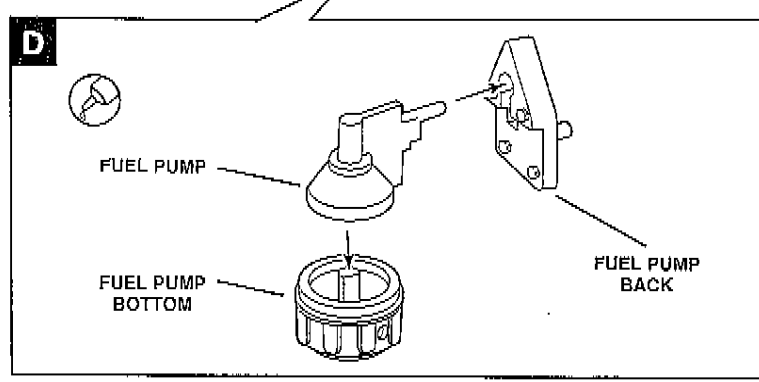
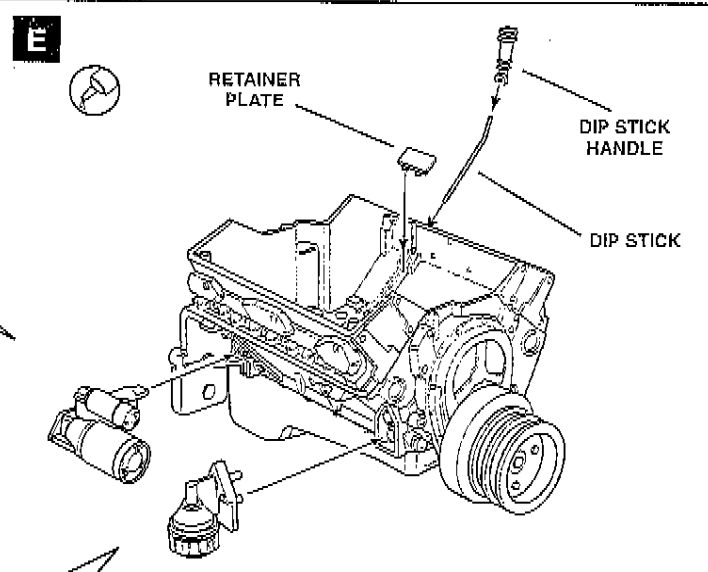
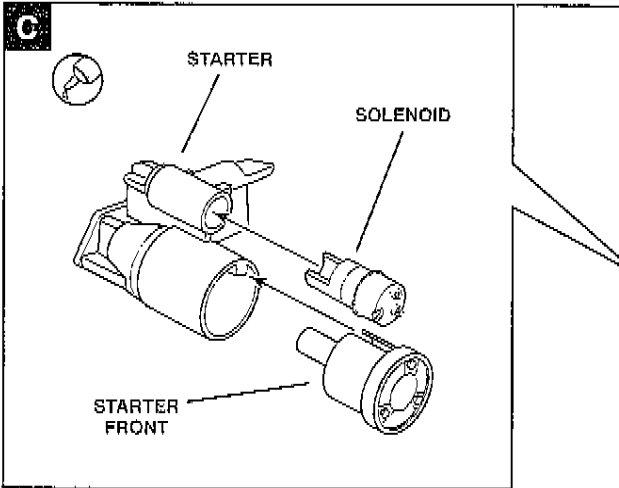
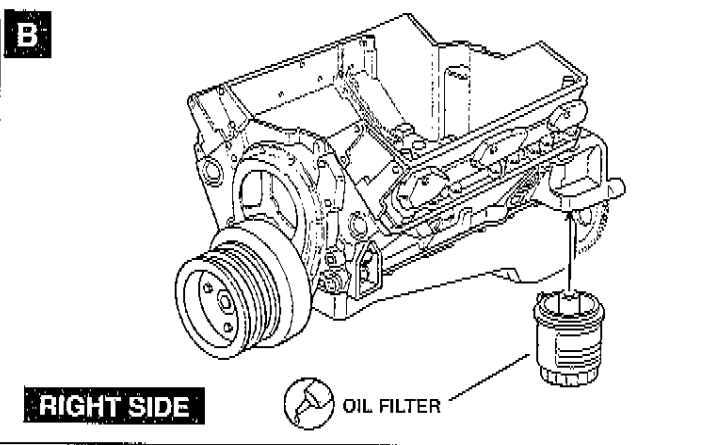
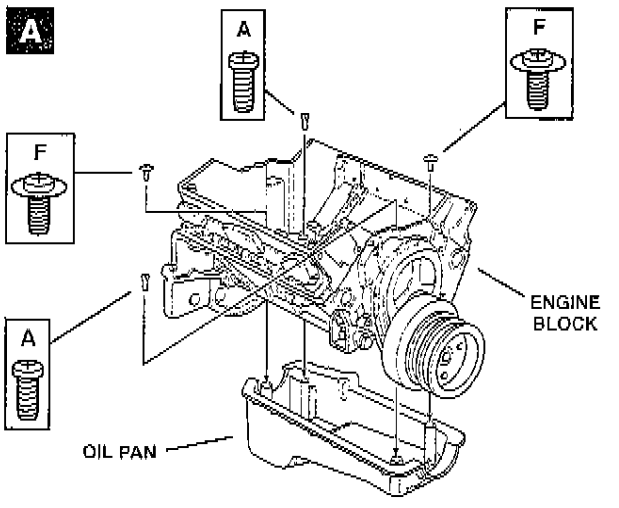

2

BASE ASSEMBLY

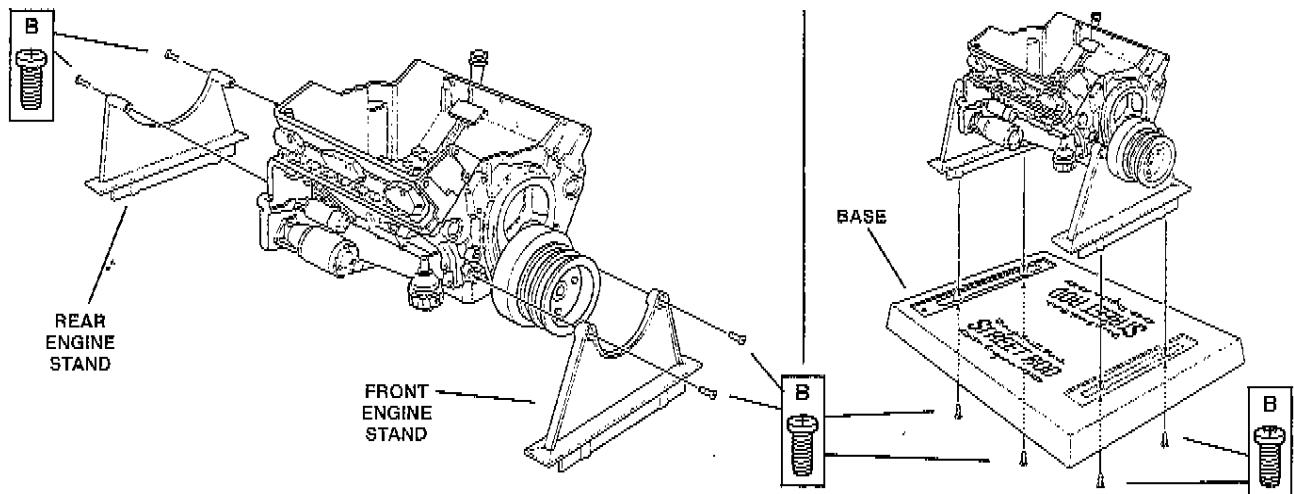

3

CARBURATOR ASSEMBLY

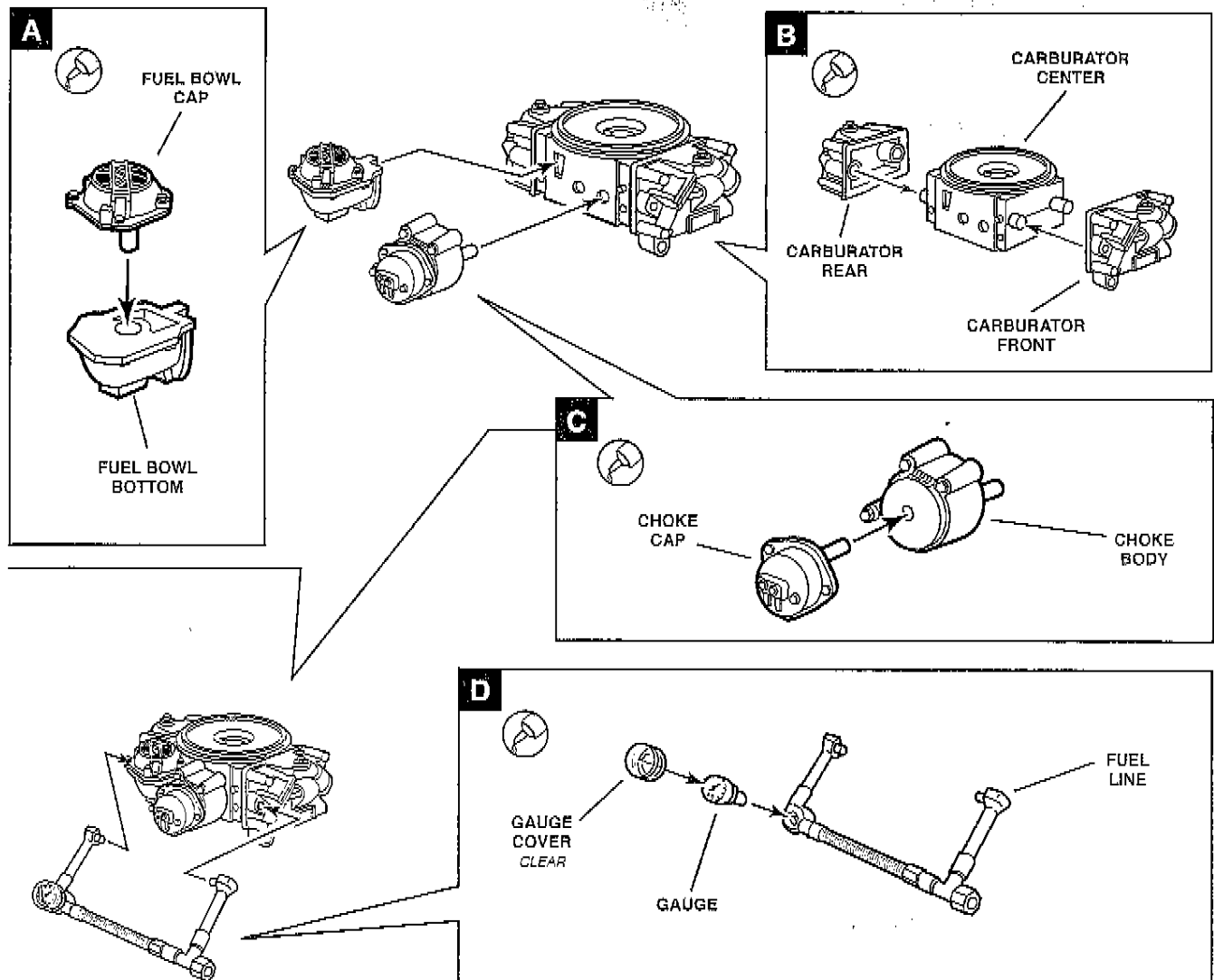

4

DISTRIBUTOR / ENGINE TOP ASSEMBLY

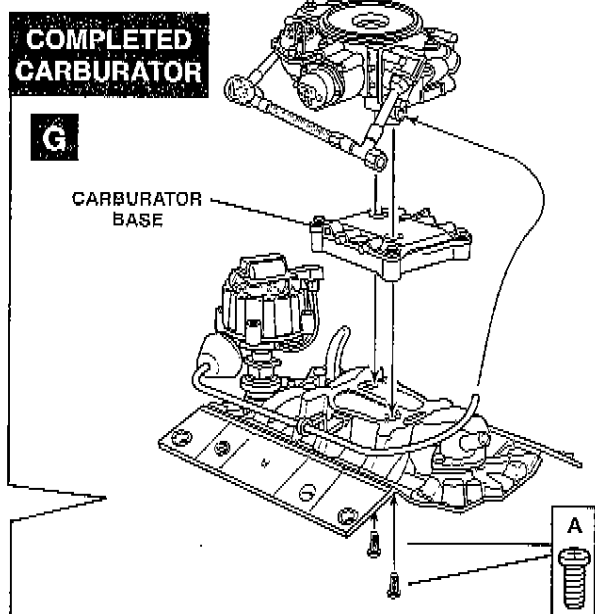
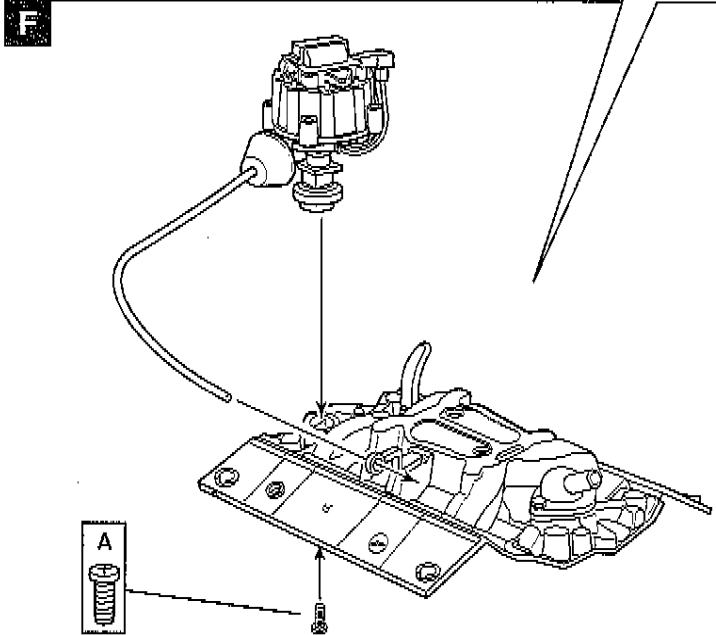
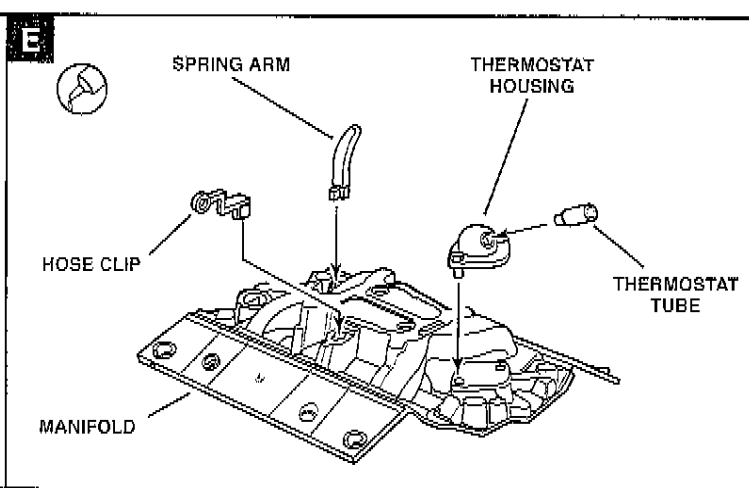
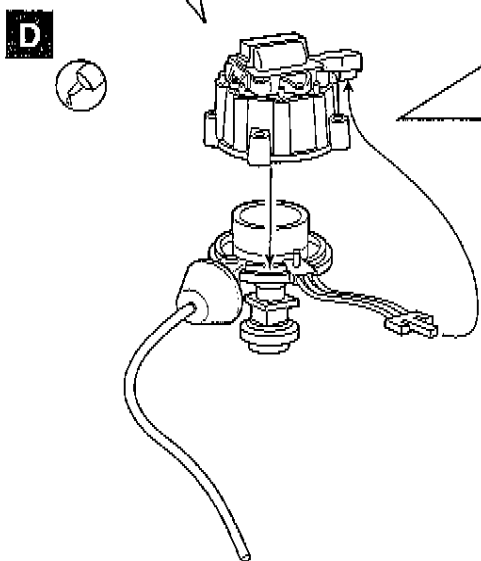
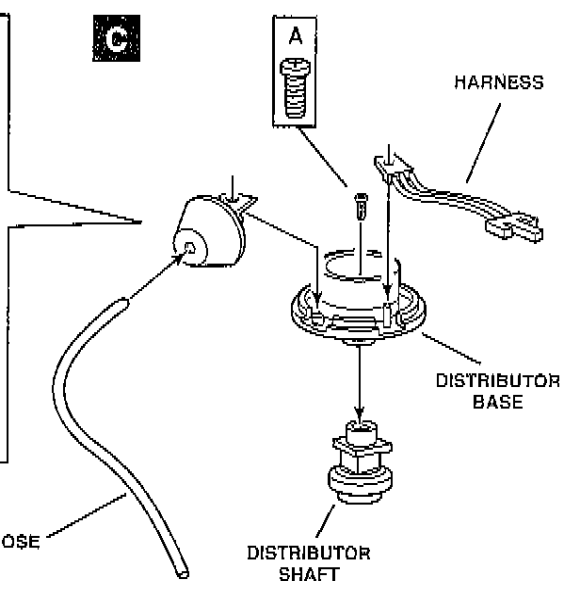
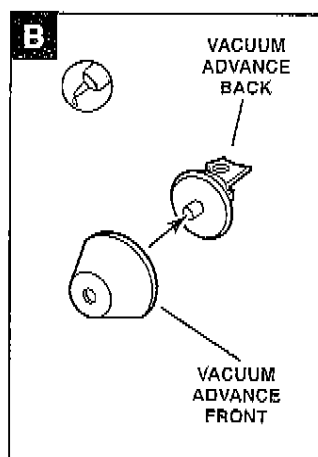
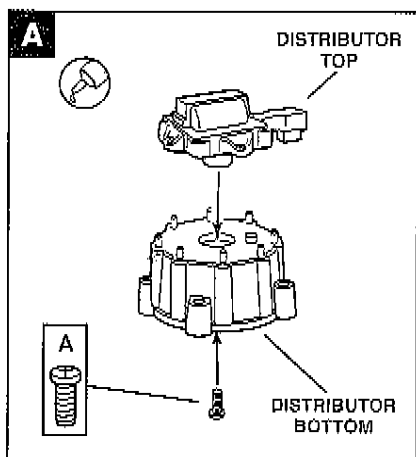

5

ENGINE TOP / PLUG ASSEMBLY

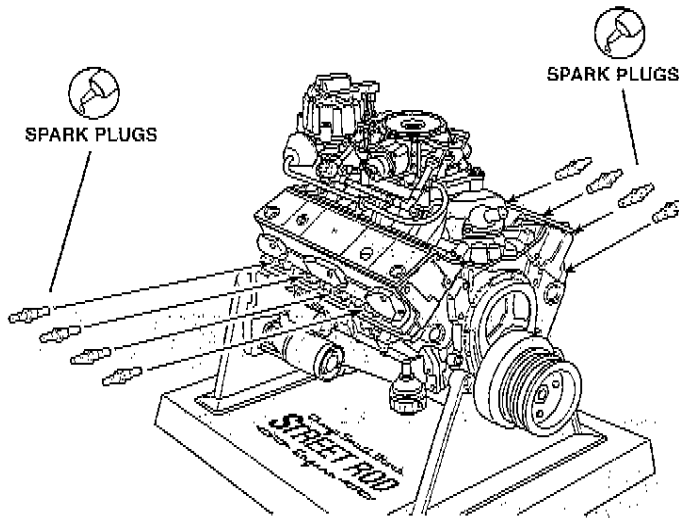
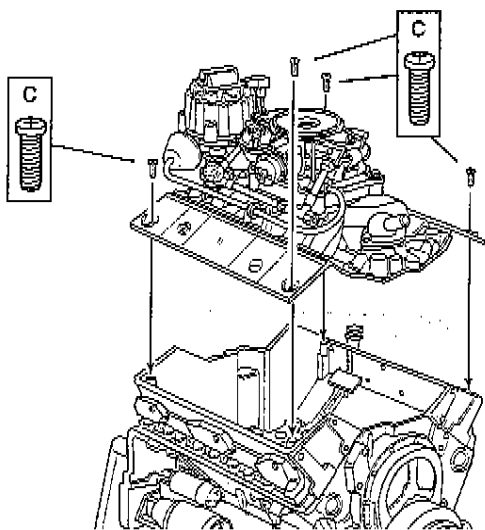
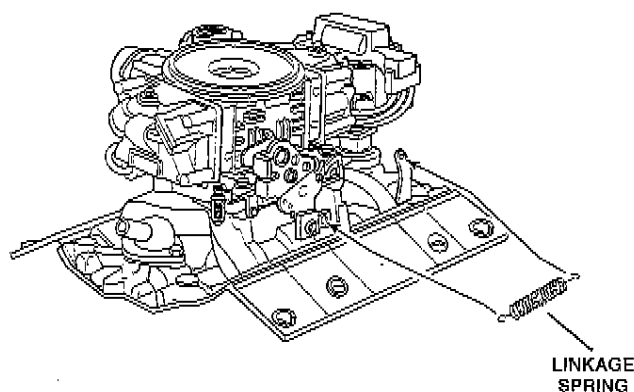
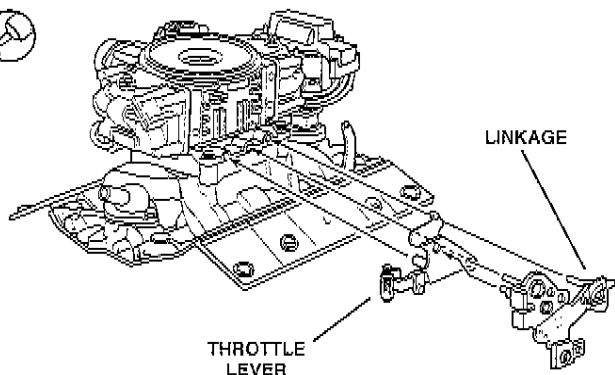

6

PLUG WIRE / VALVE ASSEMBLY

RIGHT

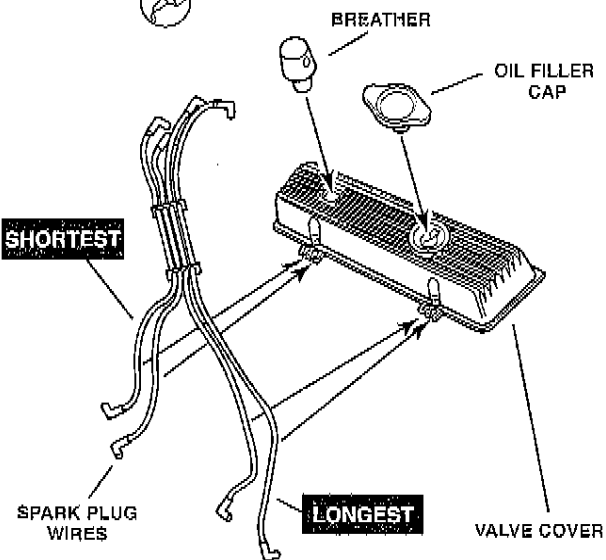

LEFT

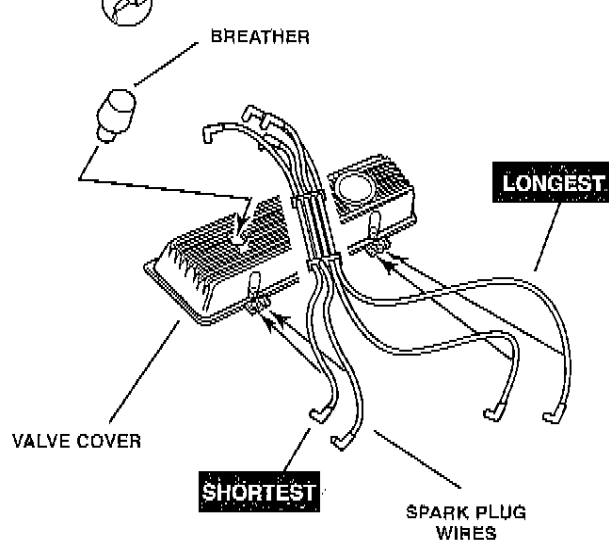

7

WIRE / GAS LINES ASSEMBLY

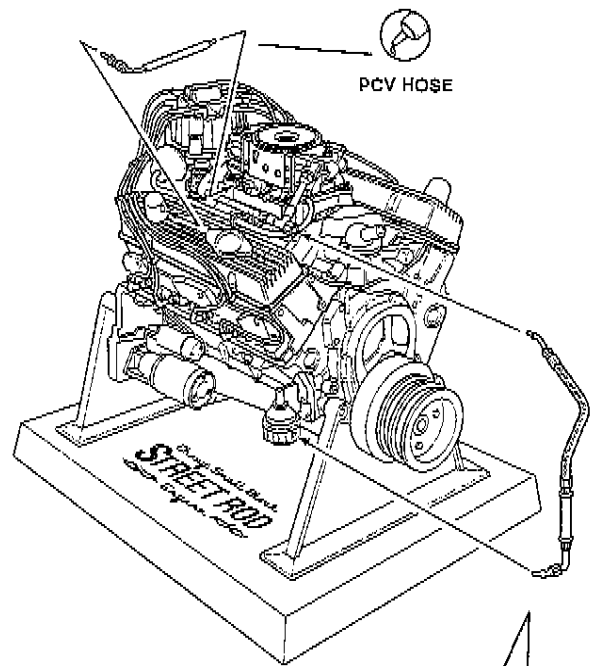
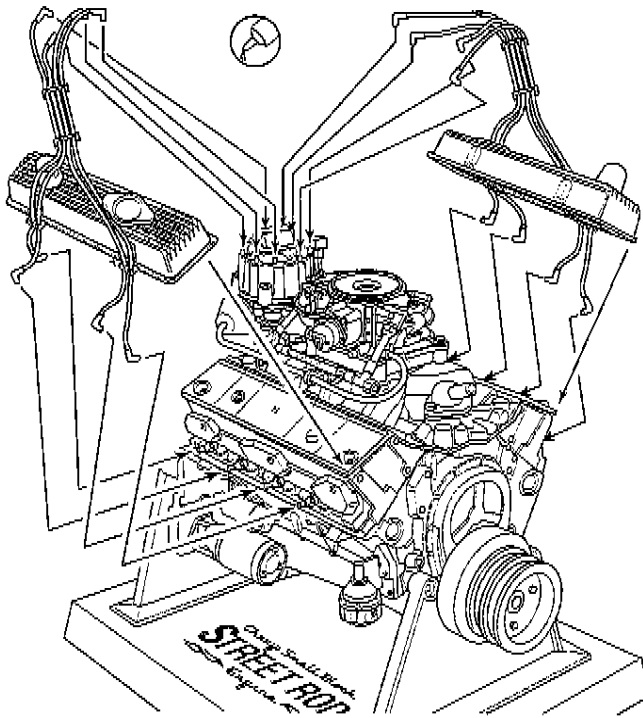

8

EXHAUST ASSEMBLY

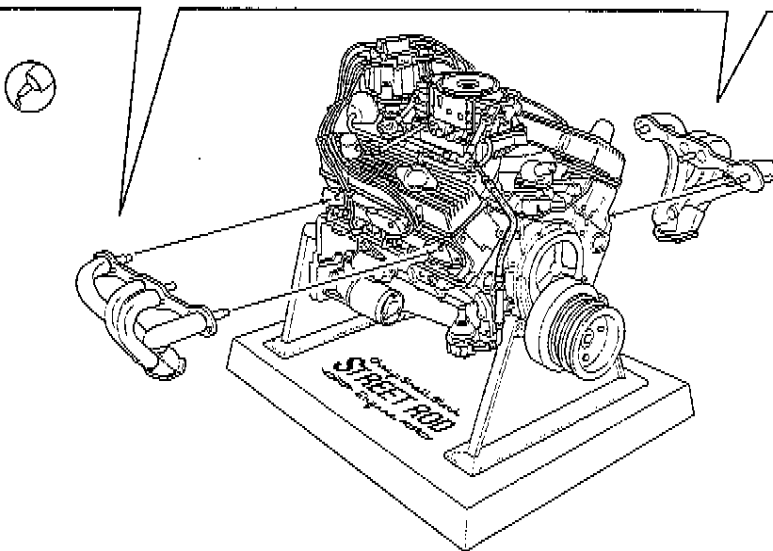
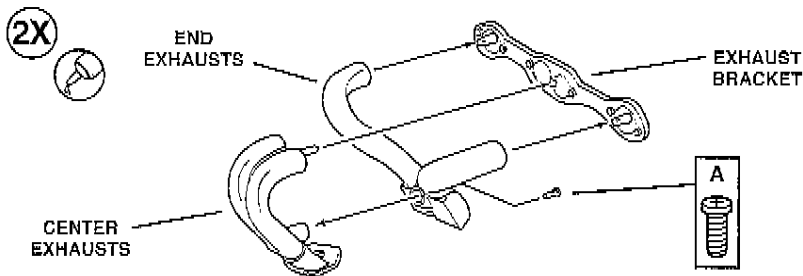

UPPER FITTING

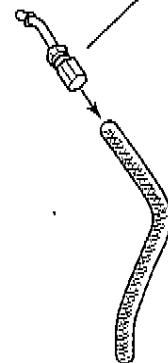

FUEL LINE

FUEL PUMP CONNECTOR

9

ENGINE FRONT ASSEMBLY

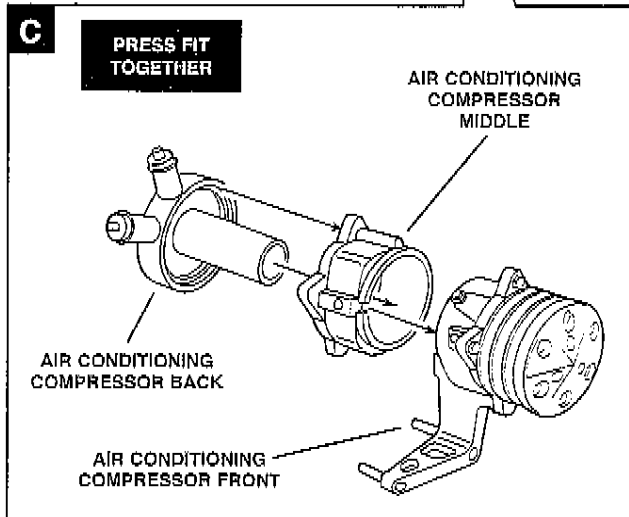
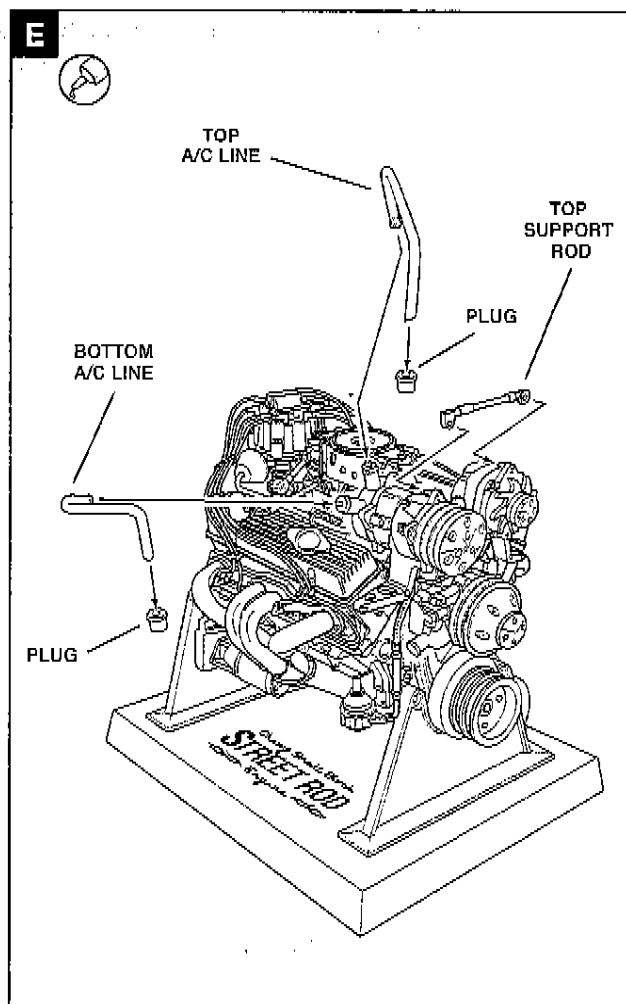
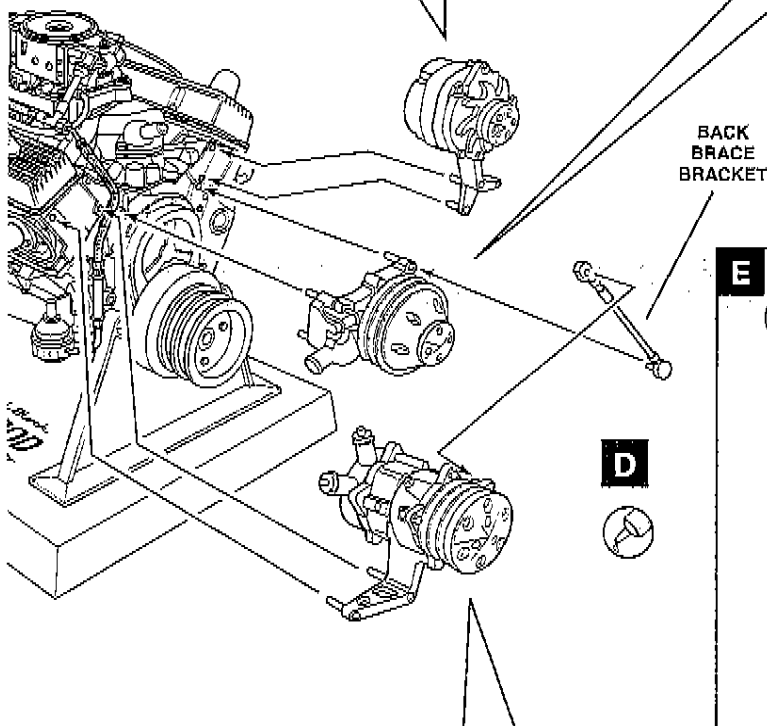
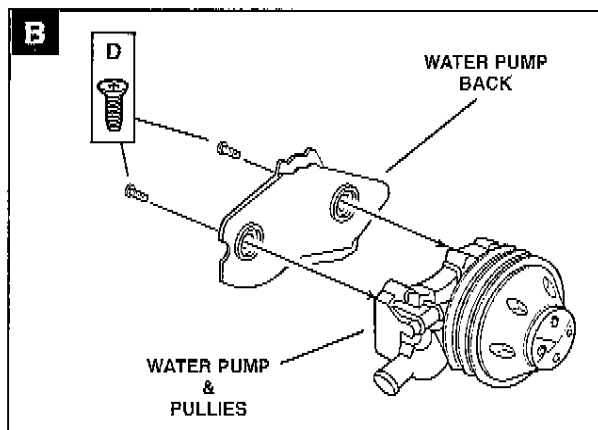
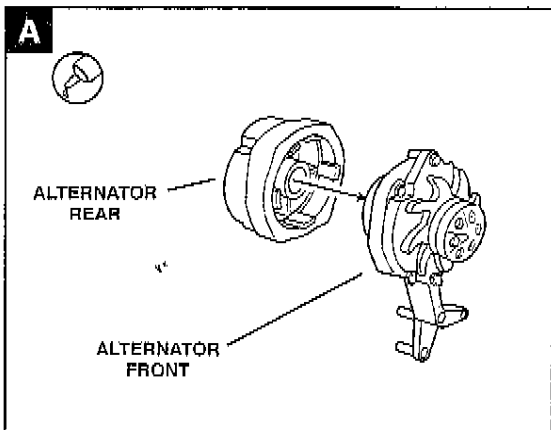

10

FINAL ASSEMBLY

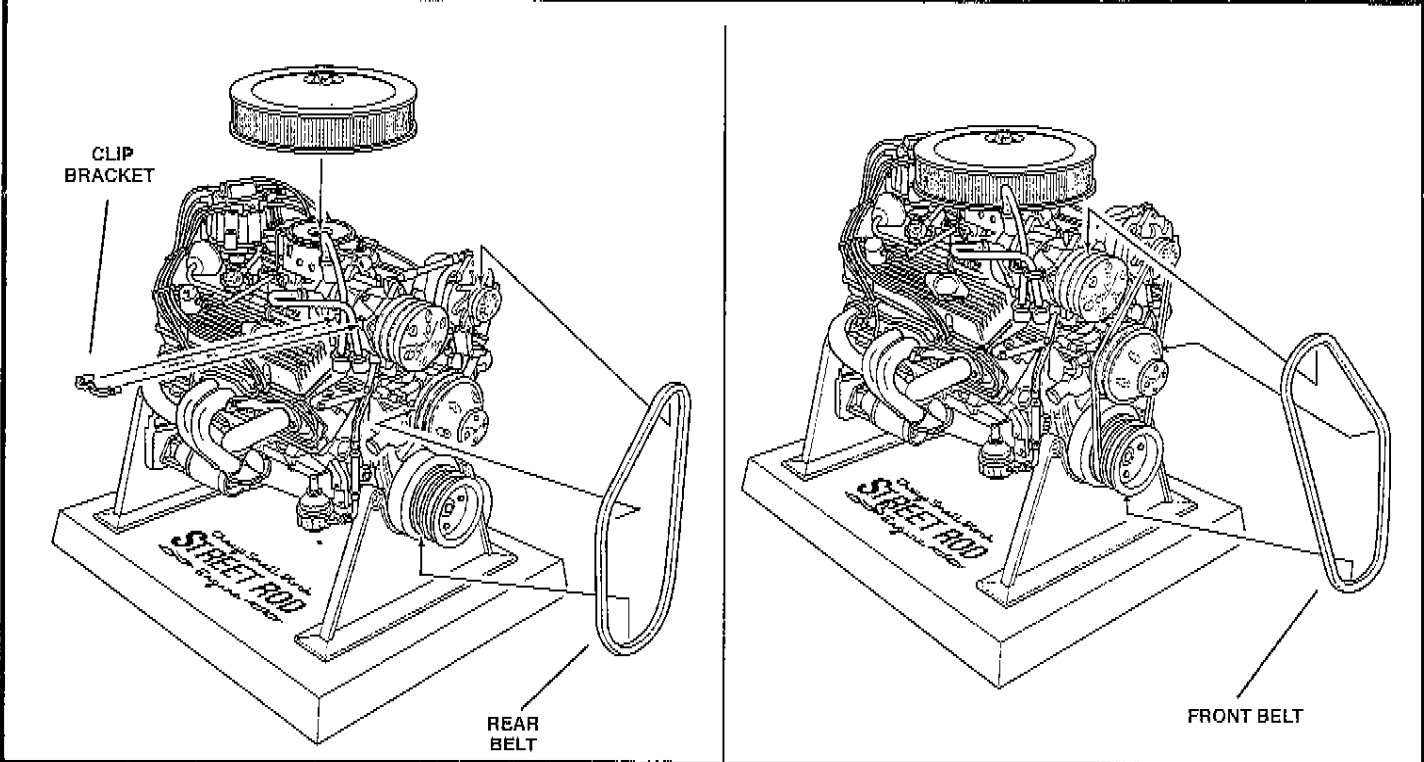

11

COMPLETED ENGINE

