

FOUR CYCLE ENGINE FS-200S

OWNER'S INSTRUCTION MANUAL

It is of vital importance, before attempting to operate your engine, to read the general 'SAFETY INSTRUCTIONS AND WARNINGS' section on pages 2-4 of this booklet and to strictly adhere to the advice contained therein.

- Also, please study the entire contents of this instruction manual, so as to familiarize yourself with the controls and other features of the engine.
- Keep these instructions in a safe place so that you may readily refer to them whenever necessary.
- It is suggested that any instructions supplied with the aircraft, radio control equipment, etc., are accessible for checking at the same time.

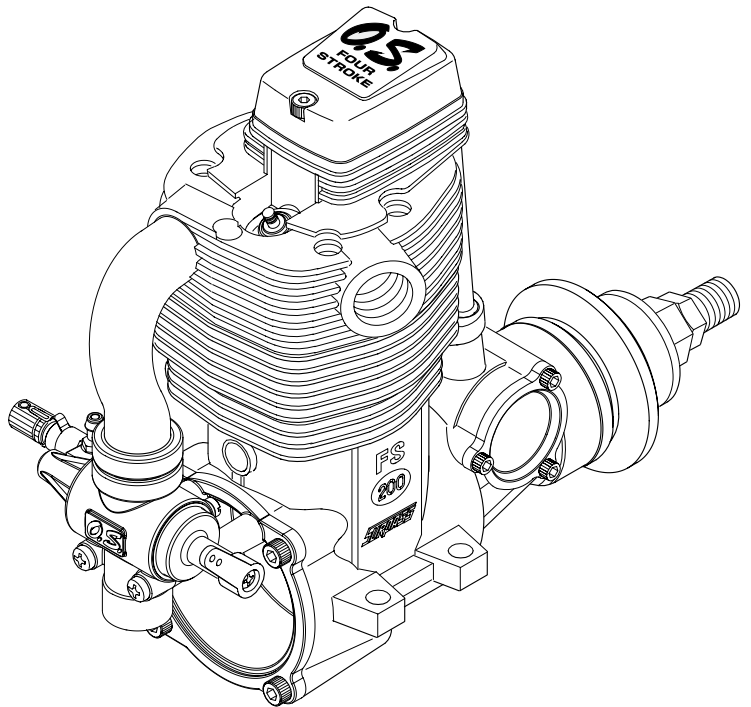

SAFETY INSTRUCTIONS AND WARNINGS ABOUT YOUR O.S. ENGINE	2-4	GLOWPLUG	16
NOTES WHEN APPLYING AN ELECTRIC STARTER	5	MIXTURE CONTROLS	17
ABOUT THE ENGINE	6	STARTING	18
ENGINE PARTS NAME	7	RUNNING-IN ("Breaking-in")	19-21
RELOCATION OF CARBURETOR CONTROLS	8	MAINTENANCE	22-23
FUEL TANK & LINES	9	ENGINE EXPLODED VIEW	24
INSTALLATION	10-11	ENGINE PARTS LIST	25
EXHAUST HEADER PIPE & SILENCER	12	CARBURETOR EXPLODED VIEW & PARTS LIST	26
PROPELLER	13-14	O.S. GENUINE PARTS & ACCESSORIES	27
FUEL	15	ENGINE THREE VIEW DRAWINGS	28

SAFETY INSTRUCTIONS AND WARNINGS ABOUT YOUR O.S. ENGINE

Remember that your engine is not a "toy", but a highly efficient internal-combustion machine whose power is capable of harming you, or others, if it is misused or abused. As owner, you, alone, are responsible for the safe operation of your engine, so act with discretion and care at all times.

If at some future date, your O.S. engine is acquired by another person, we would respectfully request that these instructions are also passed on to its new owner.

- The advice which follows is grouped under two headings according to the degree of damage or danger which might arise through misuse or neglect.

WARNINGS

These cover events which might involve serious (in extreme circumstances, even fatal) injury.

NOTES

These cover the many other possibilities, generally less obvious sources of danger, but which, under certain circumstances, may also cause damage or injury.

WARNINGS

- Never touch, or allow any object to come into contact with, the rotating propeller and do not crouch over the engine when it is running.



- A weakened or loose propeller may disintegrate or be thrown off and, since propeller tip speeds with powerful engines may exceed 600 feet (180 metres) per second, it will be understood that such a failure could result in serious injury, (see 'NOTES' section relating to propeller safety).

- Model engine fuel is poisonous. Do not allow it to come into contact with the eyes or mouth. Always store it in a clearly marked container and out of the reach of children.



- Model engine fuel is also highly flammable. Keep it away from an open flame, excessive heat, sources of sparks, or anything else which might ignite it. Do not smoke or allow anyone else to smoke, near to it.



- Never operate your engine in an enclosed space. Model engines, like automobile engines, exhaust deadly carbon-monoxide. Run your engine only in an open area.

- Model engines generate considerable heat. Do not touch any part of your engine until it has cooled. Contact with the muffler (silencer), cylinder head or exhaust header pipe, in particular, may result in a serious burn.



2

NOTES

- This engine was designed for model aircraft. Do not attempt to use it for any other purpose.
- Mount the engine in your model securely, following the manufacturers' recommendations, using appropriate screws and locknuts.
- Be sure to use the silencer (muffler) supplied with the engine. Frequent exposure to an open exhaust may eventually impair your hearing. Such noise is also likely to cause annoyance to others over a wide area.
- Install a top-quality propeller of the diameter and pitch specified for the engine and aircraft. Locate the propeller on the shaft so that the curved face of the blades faces forward-i.e. in the direction of flight. Firmly tighten the propeller nut, using the correct size wrench.
- Always check the tightness of the propeller nut and retighten it, if necessary, before restarting the engine, particularly in the case of four-stroke-cycle engines. If a safety locknut assembly is provided with your engine, always use it. This will prevent the propeller from flying off in the event of a "backfire", even if it loosens. Also, check the tightness of all the screws and nuts before restarting the engine.
- If you install a spinner, make sure that it is a precision made product and that the slots for the propeller blades do not cut into the blade roots and weaken them.
- Discard any propeller which has become split, cracked, nicked or otherwise rendered unsafe. Never attempt to repair such a propeller: destroy it. Do not modify a propeller in any way, unless you are highly experienced in tuning propellers for specialized competition work such as pylon-racing.
- Use an electric starter for this engine. The wearing of safety glasses is also strongly recommended.

3

! NOTES

- Take care that the glow plug clip or battery leads do not come into contact with the propeller. Also check the linkage to the throttle arm. A disconnected linkage could also foul the propeller.
- After starting the engine, carry out any needle-valve readjustments from a safe position behind the rotating propeller. Stop the engine before attempting to make other adjustments to the carburetor.
- Adjust the throttle linkage so that the engine stops when the throttle stick and trim lever on the transmitter are fully retarded. Alternatively, the engine may be stopped by cutting off the fuel supply. Never try to stop the engine physically.
- Take care that loose clothing (ties, shirt sleeves, scarves, etc.) do not come into contact with the propeller. Do not carry loose objects (such as pencils, screwdrivers, etc.) in a shirt pocket from where they could fall through the propeller arc.
- Do not start your engine in an area containing loose gravel or sand. The propeller may throw such material in your face and eyes and cause injury.
- For their safety, keep all onlookers (especially small children) well back (at least 20 feet or 6 meters) when preparing your model for flight. If you have to carry the model to the take-off point with the engine running, be especially cautious. Keep the propeller pointed away from you and walk well clear of spectators.
- **Warning!** Immediately after a glowplug-ignition engine has been run and is still warm, conditions sometimes exist whereby it is just possible for the engine to abruptly restart if the propeller is casually flipped over compression **WITHOUT** the glowplug battery being reconnected. Remember this if you wish to avoid the risk of a painfully rapped knuckle!

4

NOTES WHEN APPLYING AN ELECTRIC STARTER

Do not over-prime. This could cause a hydraulic lock and damage the engine on application of the electric starter.

If over-primed, remove glowplug, close needle-valve and apply starter to pump out surplus fuel. Cover the head with a rag to prevent pumped out fuel from getting into your eyes.

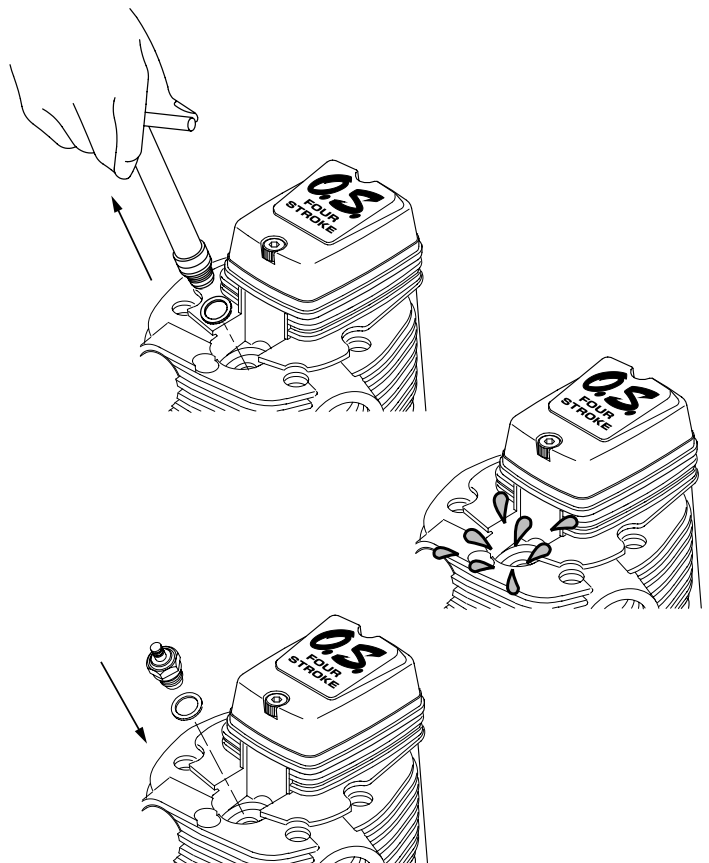

5

This is an overhead valve four stroke cycle engine for model aircraft use. This engine has a largest displacement of 32.4cc in the FS series and is suitable for scale and sport models.

The engine is equipped with an easy to adjust 80N carburetor which can be reversed 180° and supplied with a F-6010 silencer which produces the milder four stroke sound.

STANDARD ACCESSORIES

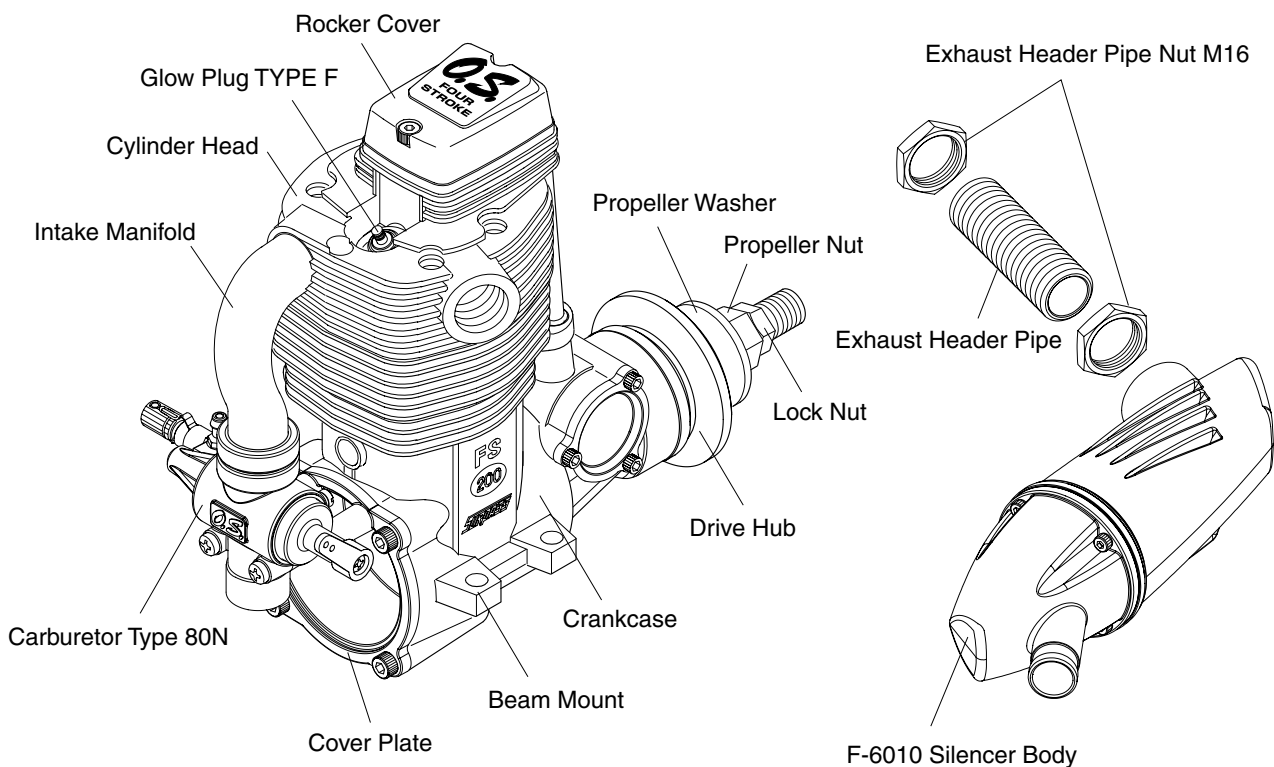
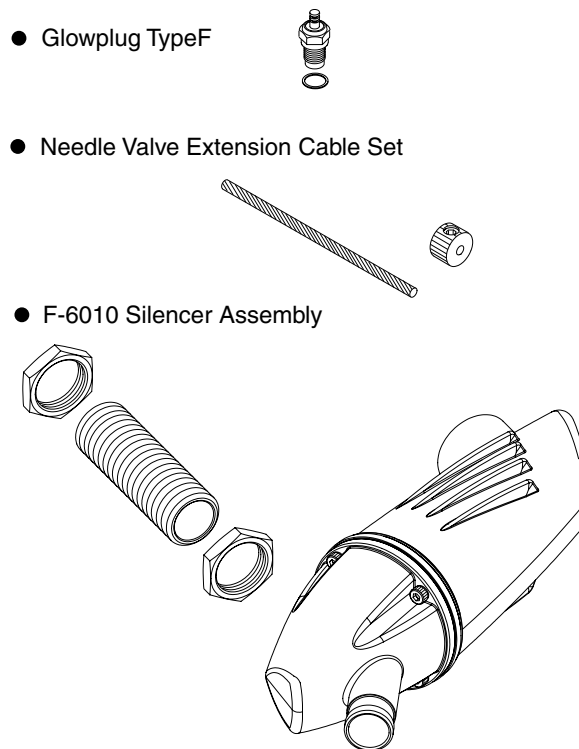

1. Remove the carburetor retaining screws and remove the silicone tube between the carburetor and cover plate. Then, pull out the carburetor gently from the intake manifold.
2. Rotate the carburetor 180° and insert on the intake manifold straight and gently. Do not force at an angle or the O ring inside the carburetor may be damaged.
3. Re-install the retaining screws. Then, connect the carburetor and cover plate with a new silicone tube of 2.5mm inner dia and 5mm outer dia 85mm in length cut from commercially available tubing.

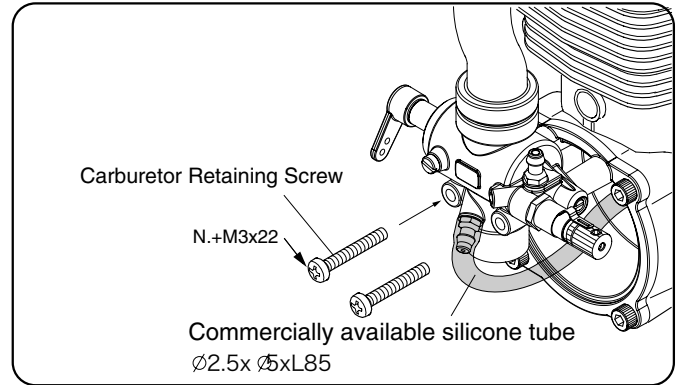
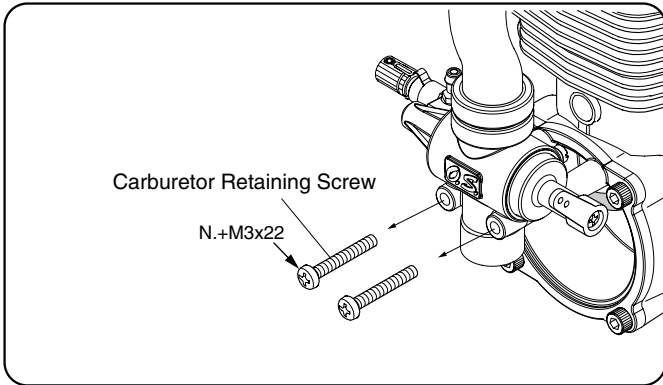
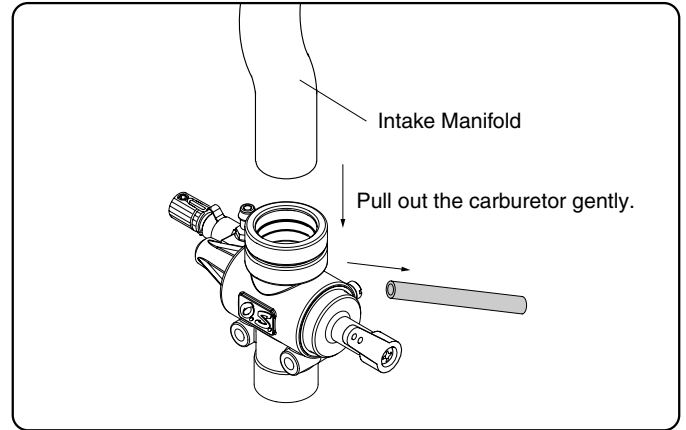

8

- Make sure that the tank is well rinsed out with methanol or glow fuel before installation and that the pickup weight is well clear of the bottom of the tank when held vertically.
- The suggested fuel tank size is 500cc or 14 oz. This will give approximately 10 minutes running time when some part-throttle operation is included.
- Locate the fuel tank so that the center line of the tank is 10 to 15mm below the center line of the needle-valve.
- For plumbing, use heavy duty silicone tube of 2.5mm inner dia and 5mm outer dia.

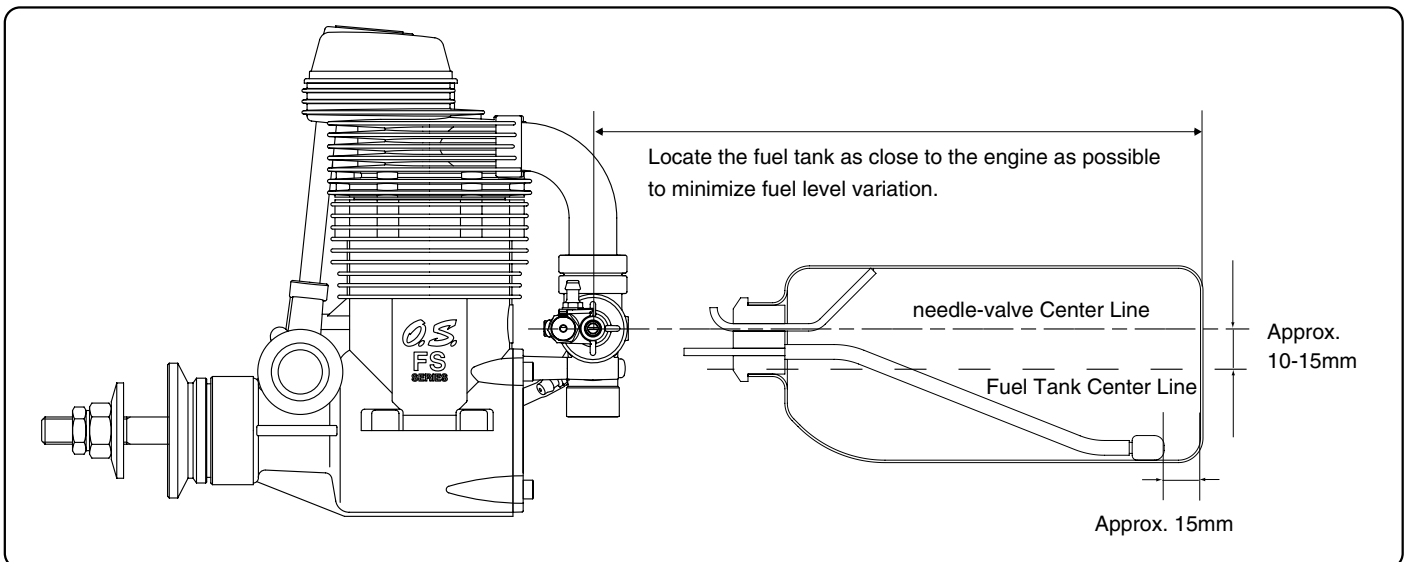

9

Because the FS-200S is a powerful, large-displacement, single-cylinder four-stroke-cycle engines, it is essential to use very substantial engine mounting. Conventional wooden mounting beams should be of rigid hardwood and of at least 15mm or 5/8-in square section.

Make sure that the mounting beams are parallel and that their top surfaces are in the same plane.

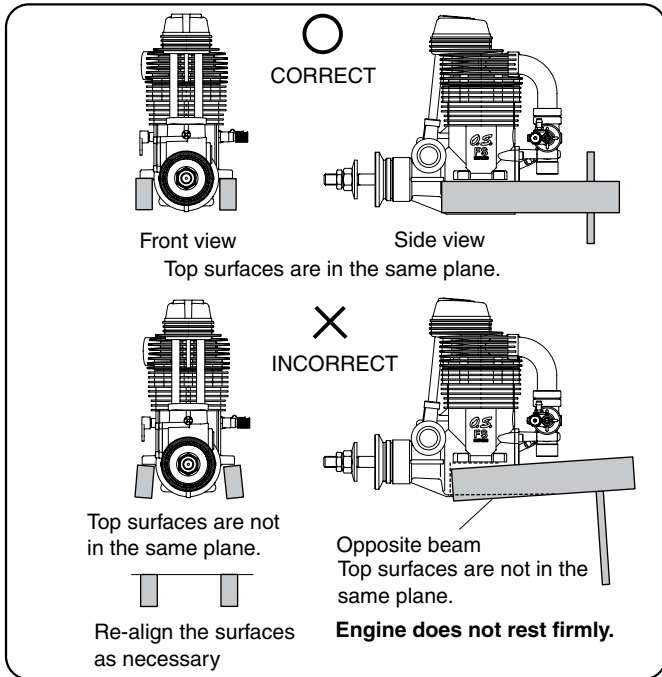

How to fasten the mounting screws.

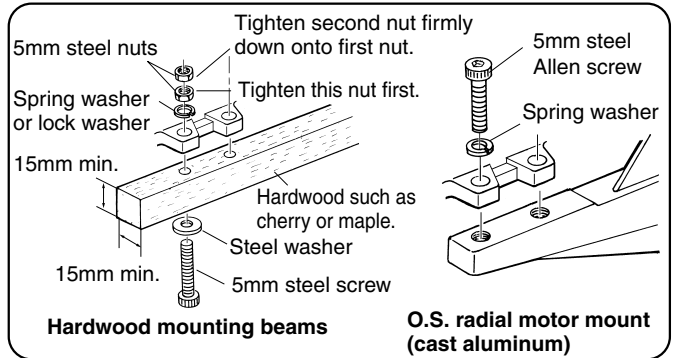

Make sure that these mounting beams are accurately aligned and firmly integrated with the airframe, reinforcing the adjacent structure to absorb vibration. Use 5mm or larger steel screws, preferably Allen type hexagon socket head cap screws, with washers and locknuts, for bolting the engine to the bearers. As an alternative to wooden beam mounting, a special O.S. cast aluminium radial motor mount, complete with 5mm mounting screws, is available as an optional extra part (Code No.71904200) , when front bulkhead (firewall) type mounting is called for. Engine installation should, be made in such a way that basic maintenance can be conveniently carried out.

It is suggested to use Lock Washers (available as an optional extra) with engine installing screws or apply LOCTITE to the screws to prevent them from loosening.

THROTTLE LINKAGE

Before connecting the throttle to its servo, make sure that the throttle arm and linkage safely clear any adjacent part of the airframe structure, etc., as the throttle is opened and closed.

Connect the linkage so that the throttle is fully closed when the transmitter throttle stick and its trim lever are at their lowest settings and fully open when the throttle stick is in its fully-open position..

Carefully align the appropriate holes in the throttle arm and servo horn so that they move symmetrically and smoothly through their full travel.

NEEDLE-VALVE EXTENSION

The needle-valve supplied with this engine is designed to incorporate an extension so that, when the engine is enclosed within the fuselage, the needle-valve may be adjusted from the outside. For this purpose, a Needle Valve Extension Cable Set is supplied with the engine. If a longer extension is required, cut a commercially available rod to the required length, bend one end to an L shape, insert it into needle's center hole and secure it by tightening the set-screw in the needle-valve knob with 1.5mm Allen key.

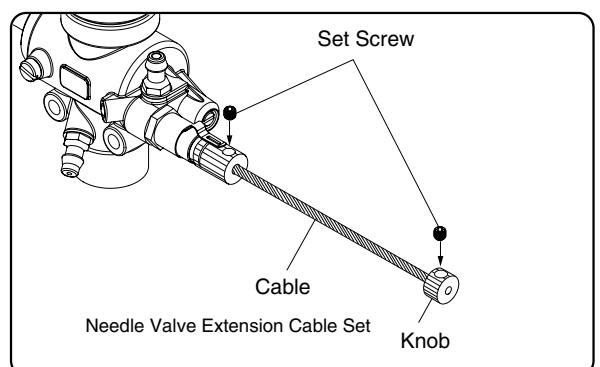

Install these in the following sequence.

Screw the exhaust header pipe into the exhaust port until it "bottoms", then unscrew it approximately 90 degrees, and secure with locknut.

Screw the silencer onto the header pipe more than 10mm and maximum 30mm to achieve the desired exhaust angle and tighten the other locknut.

The application of a heatproof silicone sealant to the threads of the exhaust system is recommended to reduce the risk of joints loosening and the leakage of exhaust gases and oil residue. Also, make a habit to check the tightness periodically and retighten if necessary.

The exhaust outlet can be rotated every 90 degrees by removing the four assembly screws and rotate the rear part so that the exhaust outlet can point required direction.

Be careful not to move the two gaskets and baffle plate at this time.

Reminder:

Model engines generate considerable heat and contact with the header pipe or silencer may result in a serious burn. If you need to tighten the silencer joints, which may loosen when they are hot, use a thick folded cloth for protection.

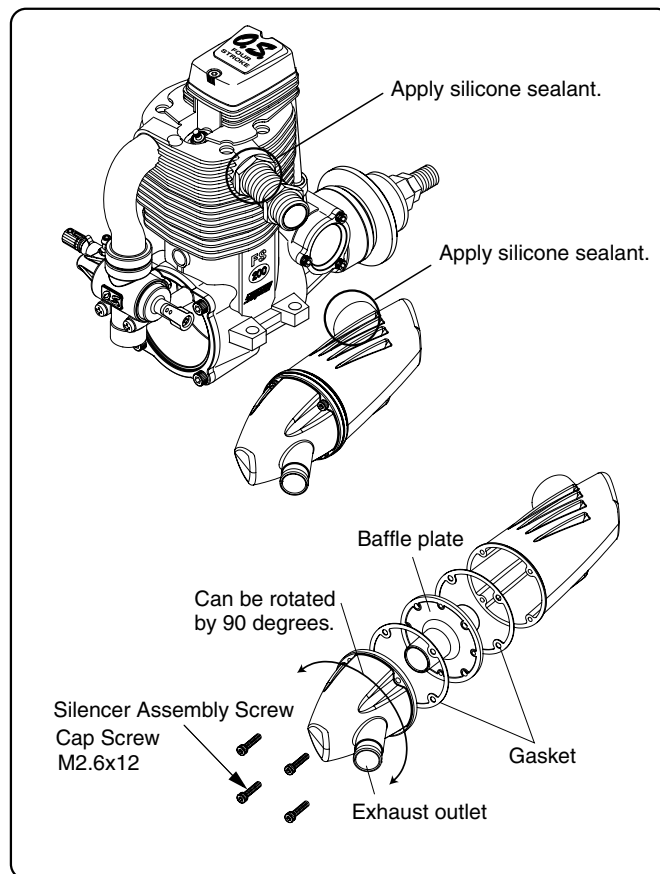

The choice of propeller depends on the design and weight of the aircraft and on the type of flying in which you will be engaged. Determine the best size and type after practical experimentation. As a starting point, refer to the props listed in the accompanying table. Slightly larger, or even slightly smaller, props than those shown in the table may be used, but remember that propeller noise will increase if blade tip velocity is raised, due to higher rpm or if a larger-diameter / lower-pitch prop is used.

Warning:

Make sure that the propeller is well balanced. An unbalanced propeller and / or spinner can cause serious vibration which may weaken parts of the airframe or affect the safety of the radio-control system. DO NOT forget the WARNINGS and NOTES on propeller and spinner safety given on pages 2,3 and 4.

Type	Size (DxP)
Sport / Scale	15x12-14, 16x12-14
	17x10-13, 18x6-10
	17x12-13, 18x8-12, 20x8

PROPELLER & SPINNER ATTACHMENT

There is a risk, particularly with powerful four-stroke engines, of the propeller flying off if the prop nut loosens due to detonation ("knocking") in the combustion chamber when the engine is operated too lean, or under an excessively heavy load.

Obviously, this can be very hazardous. To eliminate such dangers, the O.S. Safety Locknut Assembly was devised. Install this as follows:

1. Ream the propeller shaft hole to 8.1mm bore with an appropriate reamer, checking that the hole is exactly centered.

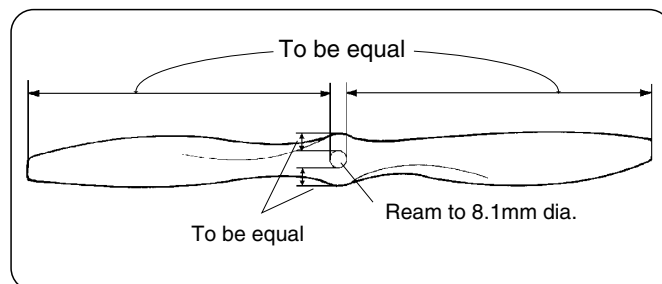

2. Install the prop to the engine shaft, followed by the retaining washer and prop nut and tighten firmly with a 14mm wrench. (not supplied).
3. Add the special tapered and slotted locknut and secure with a 12mm wrench while holding the prop nut with the 14mm wrench. (not supplied).

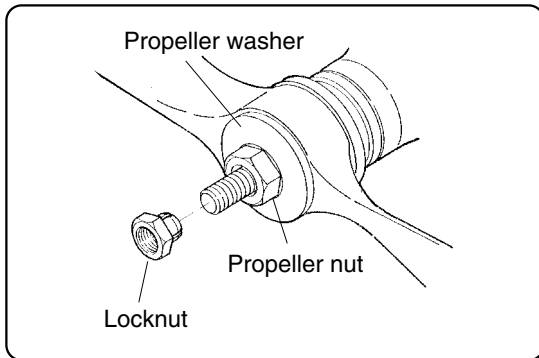
**Note:**

Some spinners which are retained at the top of the cone cannot be used with the prop locknut supplied with the engine. In this case, optional locknut sets are available from O.S. – Propeller Locknut Set for Spinner (Code No.45910200 4mm) and (Code No.45910300 5mm).

NOTE:

Make a habit of always checking the tightness of the propeller before starting the engine. Remember that, especially with wooden propellers, there is a tendency for the material to shrink, or for it to be reduced by the serrated face of the drive hub. Retighten the propeller nut if necessary after loosening the Safety Propeller Locknut. The locknut should be tightened firmly after retightening the propeller nut.

Since the FS-200S is intended to be started with an electric starter, the addition of a spinner assembly for centering the starter sleeve is desirable. Special propeller locknut sets are available for use with spinners.

Use a good quality well balanced spinner, enclosing the propeller boss. Make sure that it is of precision-made and sturdy construction so that the spinner shell cannot loosen when the starter is used.

Make sure the spinner notches do not interfere the propeller. If they do, cut the notches to clear.

The FS-200S should be operated on a methanol based fuel containing not less than 18% castor-oil, or a top quality synthetic lubricant (or a mixture of both), plus a small percentage (5-30%) of nitromethane for improved flexibility and power. The carburettor is adjusted at the factory for a fuel containing 20% lubricant and 10% nitromethane.

Some commercial fuels also contain coloring additives as an aid to fuel level visibility. In some cases, these additives have indicated slightly negative effects on performance. We would suggest that you use such fuels only if you are satisfied that they do not adversely affect running qualities when compared with familiar standard fuels.

When changing to a fuel brand or formula that is different from the one to which you are accustomed, it is a wise precaution to temporarily revert to in-flight running-in procedures, until you are sure that the engine is running entirely satisfactorily.

Reminders:

All model engine fuel is poisonous. Do not allow it to come into contact with the eyes or mouth. Always store it in a clearly marked container and out of the reach of children.

Though not as volatile as gasoline, model engine fuel is also highly inflammable.

Keep it away from an open flame, excessive heat, sources of sparks, or anything else that might ignite it. Smoking is firmly discouraged.



Since the compatibility of the glowplug and fuel may have a marked effect on performance and reliability, it is suggested to use the O.S. Type F plug when it is necessary to replace. Carefully install plug finger-tight, before final tightening with the correct size plug wrench.

The role of the glowplug

With a glowplug engine, ignition is initiated by the application of a 1.5-volt power source. When the battery is disconnected, the heat retained within the combustion chamber remains sufficient to keep the plug filament glowing, thereby continuing to keep the engine running. Ignition timing is 'automatic': under reduced load, allowing higher rpm, the plug becomes hotter and, appropriately, fires the fuel/air charge earlier; conversely, at reduced rpm, the plug become cooler and ignition is retarded.

Glowplug life

Particularly in the case of very high performance engines, glowplugs must be regarded as expendable items. However, plug life can be extended and engine performance maintained by careful use, i.e.:

- Install a plug suitable for the engine.
- Use fuel containing a moderate percentage of nitromethane.
- Do not run the engine too lean and do not leave the battery connected while adjusting the needle.

When to replace the glowplug

Apart from when actually burned out, a plug may need to be replaced because it no longer delivers its best performance, such as when:

- Filament surface has roughened and turned white.
- Filament coil has become distorted.
- Foreign matter has adhered to filament or plug body has corroded.
- Engine tends to cut out when idling.
- Starting qualities deteriorate.

16

■ Carburetor Parts Name

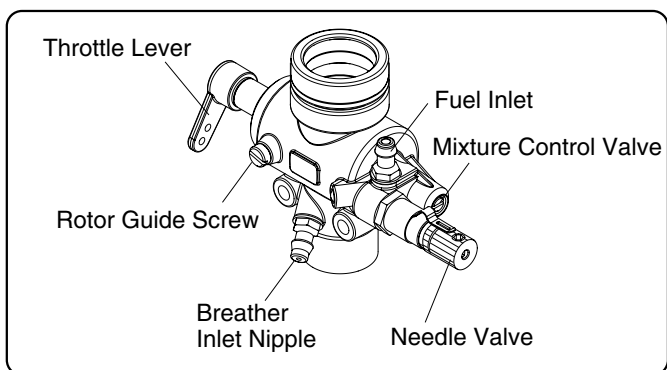

Two mixture controls are provided on this Carburetor.

•The Needle Valve

When set to produce maximum power at full throttle, this establishes the basic fuel/air mixture strength. The correct mixture is then maintained by the carburetor's built-in automatic mixture control system to cover the engine's requirements at reduced throttle settings.

•The Mixture Control Valve

This meters fuel flow at part-throttle and idling speeds to ensure reliable operation as the throttle is opened and closed. The Mixture Control Valve is factory set for the approximate best result. First run the engine as received and readjust the Mixture Control Screw only if necessary.

The sequence in which these controls are adjusted is explained in the succeeding sections, under Starting, Running-in and Idling Adjustment.

■ CARBURETOR CARE & MAINTENANCE

If you experience difficulty in achieving consistent mixture setting it could be due to foreign debris in the carburetor. Carefully disassemble the carburetor and wash in methanol. Do not use gasoline or kerosene that can effect the silicone rubber "O" rings.

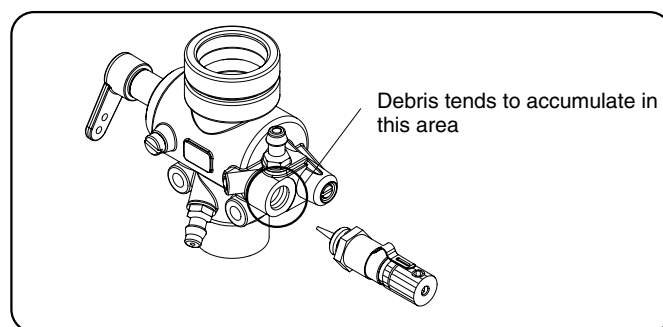

17

The FS-200S is not equipped with manual choke controls, as it is intended for use with an electric starter only.

A high-torque electric starter not only makes starting the engine easier, it dispenses with the need for a choke valve by turning the engine over fast enough to prime the cylinder.

Starting procedure is as follows:

1. Check that the current to the glowplug is switched off.
2. Check that the polarity of the starter battery leads rotates the engine counter-clockwise when viewed from the front.
3. Open the needle-valve 3-4 turns from the fully closed position and set the throttle in the fully open position.
4. Apply the starter and press the starter switch for 5-6 seconds, or until fuel is seen to emerge from the exhaust outlet, indicating that the cylinder is now primed.
5. Close the throttle-arm to within 15-20° of the fully closed position and slowly turn the prop "backwards" (clockwise) by hand approximately 1.5 turns until it is arrested by compression. This is to enable the kinetic energy of the prop to subsequently assist the starter through the compression stroke to start the engine.
6. Energize the glowplug and apply the starter. If the starter fails to rotate the engine completely, this may be due to the cylinder being over-primed, or to the starter battery being insufficiently charged.

7. Check these conditions and, instead of pressing the starter button after applying the starter, have the starter spinning before applying it to the engine, to give it a "running start". When the engine starts, slowly open the throttle, leaving the needle-valve at its rich starting setting to promote cool running conditions.

However, if the engine slows down because the mixture is excessively rich, the needle-valve may be closed a little to speed it up until it runs evenly.

8. Now disconnect current to the glowplug and gradually close the needle-valve so that the rpm increases. Make adjustments to the needle in small steps.

Abrupt changes at this stage are likely to cause the engine to stall. Restart the engine by simply applying the starter with the glowplug re-energized and the throttle at its starting setting.

■ How to stop the engine

Pull down the throttle lever and trim lever on the transmitter fully.

Note:

Make sure that the throttle linkage is made so that the throttle is fully closed when the throttle lever as well as trim lever on the transmitter are fully pulled down.

For long life and peak performance, every engine needs special treatment when new, known as "running-in" or "breaking-in". This is a procedure during which the engine is operated under strictly controlled conditions at the beginning of its life, in order to avoid the risk of immediate damage to certain components through becoming overheated or stressed and to help working surfaces to become smoothed and aligned for maximum mechanical efficiency thereafter. With some engines, this can require a tediously protracted period of bench running, but, as O.S. engines are manufactured to fine tolerances and from the finest quality materials, a relatively brief running-in period is sufficient and can be completed with the engine installed in the aircraft. Prolonged running with too rich a mixture and/or low speed will not complete the proper running-in. On the other hand prolonged low speed running may cause the oil in the fuel to congeal, which may result in seizure of the piston and cylinder liner.

The recommended procedure is as follows:

1. Use the same fuel and prop as you intend for flying your model.
2. Open the needle-valve 3-4 turns from the fully closed position and start the engine.
3. Open the throttle slowly to the mid speed position, and disconnect the current to the glowplug.
4. Now open the throttle slowly to the fully opened position and run the engine for no more than 5 seconds with the needle-valve tuned to produce near maximum r.p.m., then, immediately, slow the engine down again by opening the needle-valve approximately one turn. The rich mixture, so induced, will cool the engine, at the same time providing increased lubrication.
5. Repeat this process, alternately running the engine fast and slow by means of the needle-valve, while keeping the throttle fully open, then begin to extend the short periods of high-speed operation until two tanks of fuel have been consumed.

WARNING:

When ground running the engine, avoid dusty or sandy locations. If dust or grit is drawn into the engine, this can have a ruinous effect, drastically shortening engine life in a matter of minutes.

6. Following the initial running-in session, check for any looseness in the installation due to vibration, then allow the engine a period of moderately rich operation in flight.
7. For the first flight, have the needle-valve set on the rich side and adjust the throttle trim on the transmitter so that the engine does not stop when the throttle is closed to the idle setting.
8. With each successive flight, close the needle-valve very slightly until, at the end of about 10 flights, the needle is set for full power. Do not "over-lean" the mixture in an attempt to extract more power.

If overheating should be suspected at any time during flight (i.e. if the engine begins to "labor") reduce power by partially closing the throttle and land the aircraft to enable the needle-valve to be readjusted to a richer setting.

Note:

Remember that, when the engine is not yet fully run-in, the carburettor cannot be expected to give its best response in flight. Abrupt operation of the throttle, for example, may cause the engine to stall. Therefore, at this time, the aircraft should, as far as is possible, be flown at an altitude sufficient to enable an emergency landing to be safely made if the engine stops.

9. Once the engine has demonstrated that it can be safely operated at full power, the carburettor can be adjusted for optimum throttle response, following the instructions given in the next section.

■ IDLE MIXTURE ADJUSTMENT

1. Start the engine, open the throttle fully and set the needle-valve slightly rich (45-60°) from the highest r.p.m. setting.
2. Close the throttle to the idle position. Allow the engine to idle for about 5 seconds, then reopen the throttle. The engine should accelerate smoothly back to full speed.
3. If, instead, the engine responds sluggishly and emits an excess of white smoke from the exhaust, the idle mixture is too rich. Turn the mixture control valve approx. 45° clockwise to lean the idling mixture.
4. On the other hand, if the engine hesitates before picking up speed or even ceases firing completely, the idle mixture is likely to be too lean. Turn the mixture control valve 90° counter-clockwise to substantially enrich the mixture, then back again 45° clockwise.
5. In paragraphs 3 and 4 above, the 45° total movements are, of course, approximate. It will be necessary to fine-tune the mixture control screw 10-15° at a time to reach the best setting for optimum throttle response.
6. Continue re-checking the idle mixture setting until the engine responds smoothly and positively to operation of the throttle at all times.

■ REALIGNMENT OF MIXTURE CONTROL VALVE

In the course of making carburetor adjustments, it is just possible that the Mixture Control Valve setting may be upset.

Its basic setting can be re-established as follows:

- First, set the throttle lever at fully closed position.
- Turn the Mixture Control Valve counter-clockwise until it stops, then screw it out 3 turns. This is the basic position.

■ VALVE ADJUSTING

Valve clearances are correctly set before any O.S. engine leaves the factory and, in normal use, will seldom require adjustment. However, if, after a considerable amount of running time, a loss of power is detected, or if the engine has been disassembled for repair, these clearances should be checked and reset as necessary.

For checking and adjusting the valve clearances, a VALVE ADJUSTING TOOL KIT is available as an optional accessory. Also, a 5.5mm wrench (not supplied) is required for this purpose.

- Wrench 5.5mm

The kit comes in a plastic case and includes:
(Code No.72200060)

- Feeler gauge 0.04mm
- Hex. key 1.5mm
- Feeler gauge 0.1mm
- Wrench 5mm

Please pay attention to the matters described below to ensure that your engine serves you well in regard to performance, reliability and long life.

- As previously mentioned, it is vitally important to avoid operating the engine in conditions where dust, disturbed by the propeller, may be deposited on the engine and enter its working parts.
- Remember to keep your fuel container closed to prevent foreign matter from contaminating the fuel.
- Install a fuel filter to prevent dirt and dust in the fuel container from entering the fuel tank. O.S. Super Filters (L) is available as an optional extra.
- Install an in-line fuel filter between the tank and carburetor to prevent foreign matter in the tank from entering the carburetor.
- Clean these filters periodically.
- If these precautions are neglected, restriction of fuel flow may cause the engine to cut out, or the fuel/air mixture to become too lean causing the engine to overheat.

- The use of modern high-performance alcohol based model engine fuels, while promoting cooler running, improved anti-detonation combustion and increased power, have the disadvantage of causing corrosion due to the acid by-products of combustion.
The use of nitromethane in the fuel can also contribute to the problem.
- Do not close the needle-valve and mixture control valve too far as this will cause a lean setting and over heating of the engine. This can, in turn, create nitromethane oxide leading to internal rusting of the engine.
Always adjust the needlevalve slightly on the rich side of peak rpm.
- Do not leave unused fuel in the engine at the conclusion of a day's flying. Accepted practice is to cut off the fuel supply while the engine is still running at full throttle, then expel as much fuel residue as possible by turning the engine over 5-10 seconds with the electric starter.
Finally, inject some after-run oil through the glowplug hole and turn the engine over several times by hand.

- When the engine is not to be used for some months (for example, as between flying seasons), a worthwhile precaution is to remove it from the airframe and, after washing off the exterior with alcohol (not gasoline nor kerosene), remove carefully the carburetor with intake pipe, glow plug and all silicone tubing and put them safely aside. Then, immerse the engine in a container of alcohol. Rotate the crankshaft while the engine is immersed. If foreign matter is visible in the alcohol, rinse the engine again in clean alcohol. Finally, shake off and dry the alcohol, and inject some after-run oil in the glowplug hole and rotate the crankshaft several times by hand. Reinstall the carburetor with intake pipe and glowplug on the engine and keep it in a dry place after putting in a vinyl bag.

ENGINE PARTS LIST

No.	Code No.	Description
1	44504200	Rocker Cover
2	44514300	Rocker Cover Gasket
3	45761600	Rocker Arm Retainer (2pcs.)
4	44561400	Rocker Support
5	44561000	Rocker Arm (1pc.)
6	44561200	Tappet Adjusting Screw (1pair)
7	45560410	Split Cotter (2ps./1pair)
8	45560310	Valve Spring Retainer (1pc.)
9	45560210	Intake Valve Spring (1pc.)
10	45560220	Exhaust Valve Spring (1pc.)
11	44550000	Intake Valve (1pc.)
12	44551000	Exhaust Valve (1pc.)
13	44504100	Cylinder Head (W/Gasket)
14	44514100	Head Gasket (2pcs)
15	44514110	Intake Manifold Gasket (2pcs.)
16	44569400	Intake Manifold
17	44581000	Carburetor Complete (Type 80N)
18	44503400	Piston Ring
19	44503200	Piston
20	44506000	Piston Pin
21	28117000	Piston Pin Retainer
22	44505001	Connecting Rod
23	44503100	Cylinder Liner
24	44507000	Cover Plate
25	29061410	Cover Gasket
26	44502001	Crankshaft
27	27930000	Crankshaft Ball Bearing (Rear)
28	44501000	Crankcase (W/Screw)
29	45231100	Camshaft Ball Bearing (1pc.)
30	44562000	Camshaft
31	44501100	Cam Cover (W/Gasket)
31-1	44501110	Cam Cover Gasket
32	44566000	Push Rod (2pcs)
33	44566100	Push Rod Cover (1pc.)
34	45566310	Push Rod Cover "O" Ring (2pcs.)
35	44564000	Cam Follower (2pcs.)
36	29431000	Crankshaft Ball Bearing (Front)
37	44508000	Drive Hub (W/Collet)
38	45910100	Lock Nut Set
39	44525000	F-6010 Silencer Assembly
39-1	44525100	Silencer Body
39-2	44525110	Silencer Gasket (2pcs.)
39-3	22681957	Pressure Nipple (No.7)
39-4	44525200	Exhaust Header Pipe Assembly
39-5	44525210	Exhaust Header Pipe Nut m16 (1pc.)
	71615009	Glow Plug Type F
	72200080	Needle Valve Extension Cable Set

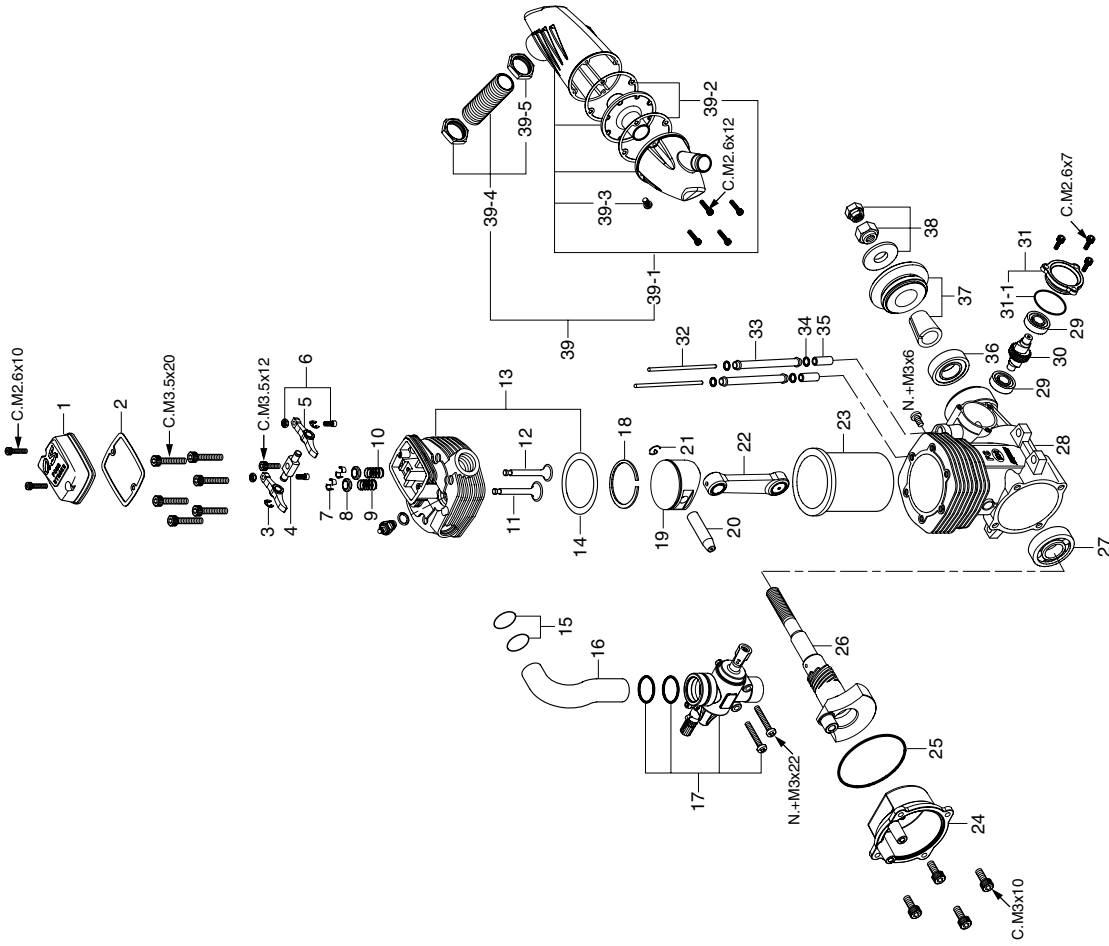

CAP SCREW SETS (10pcs./sets)

Code No.	Size	Pcs. used in an engine
79871020	M2.6x7	Cam Cover Retaining Screw (3pcs.)
79871030	M2.6x10	Rocker Cover Retaining Screw (2pcs.)
79871040	M2.6x12	Silencer Assembly Screw (4pcs.)
79871120	M3x10	Cover Plate Retaining Screw (4pcs.)
79871080	M3.5x12	Rocker Support Retaining Screw (1pc.)
79871100	M3.5x20	Cylinder Head Retaining Screw (6pcs.)

*Type of screw
 C...Cap Screw M...Oval Filler-Head Screw
 F...Flat Head Screw N...Round Head Screw S...Set Screw

The specifications are subject to alteration for improvement without notice.

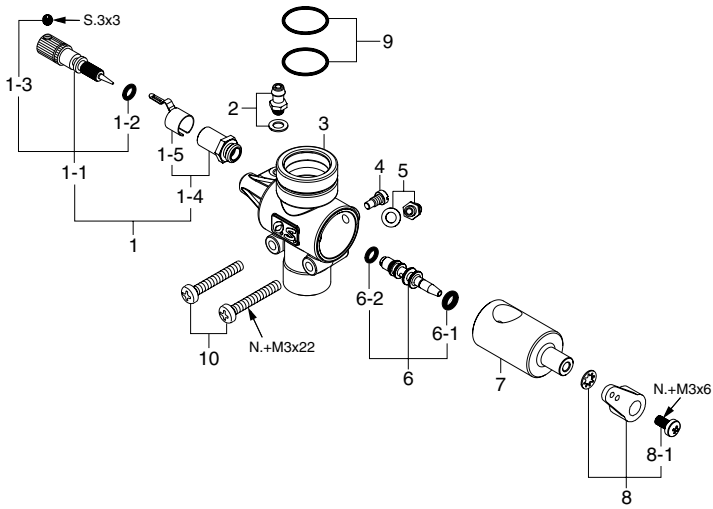

No.	Code No.	Description
1	23881900	Needle-valve Assembly
1-1	22681980	Needle Assembly
1-2	24981837	"O" Ring (2pcs.)
1-3	26381501	Set Screw
1-4	27381940	Needle-valve Holder Assembly
1-5	26711305	Ratchet Spring
2	22681953	Fuel Inlet (Nipple No.1)
3	44581100	Carburetor Body
4	45581820	Rotor Guide Screw
5	45771000	Breather Nipple (Nipple No.5)
6	44581600	Mixture Control Valve Assembly
6-1	46066319	"O" Ring (L) (2pcs.)
6-2	24881824	"O" Ring (S) (2pcs.)
7	44581200	Carburetor Rotor
8	27881400	Throttle Lever Assembly
8-1	22081313	Throttle Lever Retaining Screw
9	44581500	Carburetor Rubber Gasket (2pcs.)
10	45581700	Carburetor Retaining Screw

The specifications are subject to alteration for improvement without notice.

* Type of screw

C...Cap Screw M...Oval Fillister-Head Screw
F...Flat Head Screw N...Round Head Screw S...Set Screw

■ RADIAL MOTOR MOUNT
(71904200)

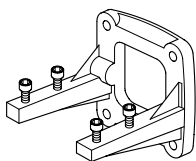

■ PROPELLER LOCKNUT SET FOR SPINNER

5/16"-M4
(45910200)

5/16"-M5
(45910300)

■ BLIND NUT (10pcs.)

M4 (79870040)

M5 (79870050)



■ LOCK WASHER (10sets)

M4 (55500003)

M5 (55500004)

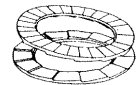

■ BOOSTER TERMINAL KIT
(72200130)



■ BOOSTER CABLE SET
(72200110)



■ VALVE ADJUSTING TOOL KIT
(72200060)



Also, a 5.5mm wrench (not supplied) is required for this purpose. • Wrench 5.5mm

■ LONG SOCKET WRENCH WITH PLUG GRIP
(71521000)

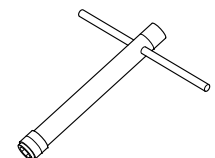

■ NON-BUBBLE WEIGHT
(71531000)



■ SUPER FILTER (L)
(72403050)



■ NON-BUBBLE WEIGHT
S (71531010)



■ CAP SCREW SET (10pcs.)

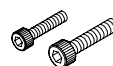

M2.6x7 (79871020)

M2.6x10 (79871030)

M2.6x12 (79871040)

M3x10 (79871120)

M3.5x12 (79871080)

M3.5x20 (79871100)

The specifications are subject to alteration for improvement without notice.

Specifications

■ Displacement	32.4 cc / 1.98 cu.in.
■ Bore	38.0 mm / 1.50 in.
■ Stroke	28.6 mm / 1.13 in.
■ Practical R.P.M.	1,800 - 10,000 r.p.m.
■ Output	2.9 ps / 9,000 r.p.m.
■ Weight	853 g / 30.09 oz.
(Silencer including exhaust header pipe)	116g (4.09 oz.)

Dimensions (mm)

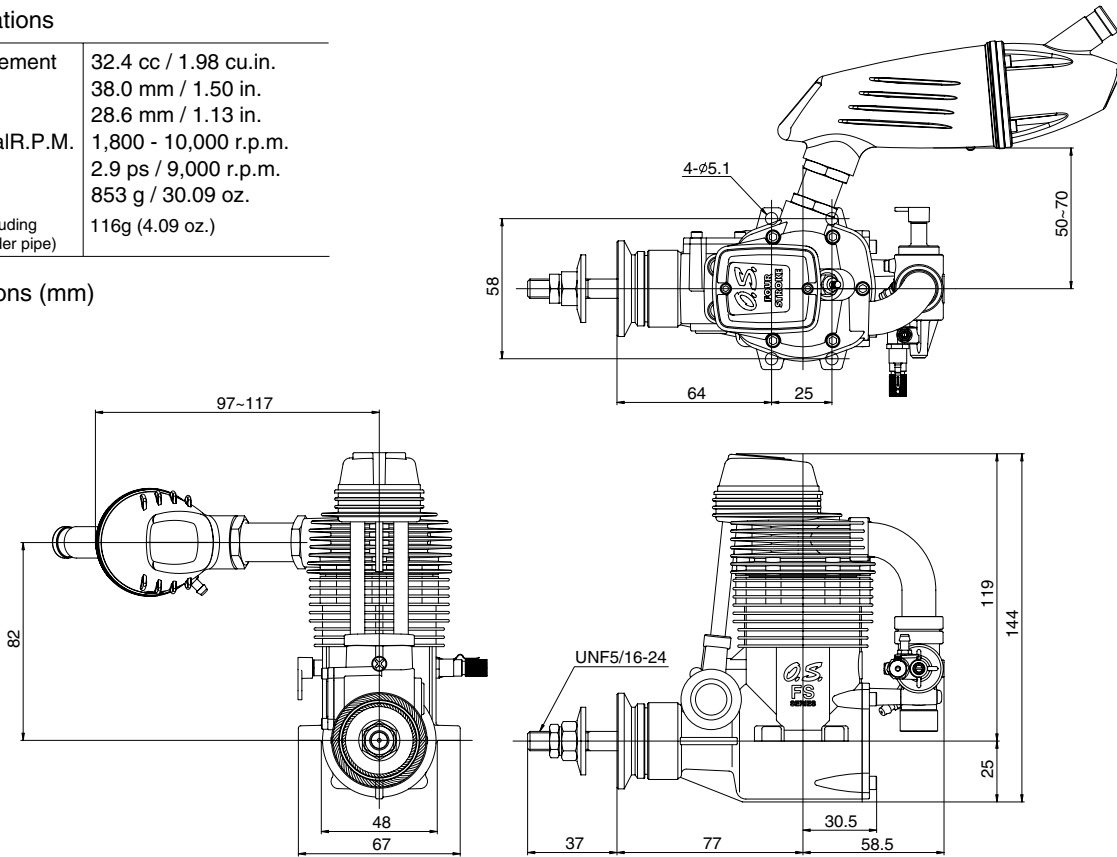

28

