O.S. ENGINE

MAX-21VZ-B(P)

OWNER'S INSTRUCTION MANUAL

It is of vital importance, before attempting to operate your engine, to read the general **'SAFETY INSTRUCTIONS AND WARNINGS'** section on pages 2-5 of this booklet and to strictly adhere to the advice contained therein.

Also, please study the entire contents of this instruction manual, so as to familiarize yourself with the controls and other features of the engine.

Keep these instructions in a safe place so that you may readily refer to them whenever necessary.

It is suggested that any instructions supplied with the vehicle, radio control equipment, etc., are accessible for checking at the same time.

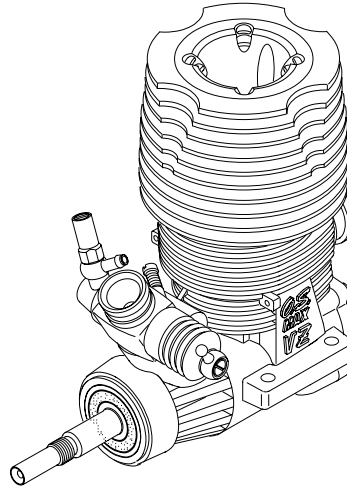
**CONTENTS**

SAFETY INSTRUCTIONS AND WARNINGS ABOUT YOUR O.S. ENGINE -----	2-5	CARBURETOR CLEANLINESS -----	17
INTRODUCTION, BASIC ENGINE PARTS -----	6	BEFORE STARTING THE ENGINE CARE AND MAINTENANCE -----	18-19
INSTALLATION -----	7	GUARANTEE -----	19
SUPER AIR CLEANER 203 -----	8-9	ENGINE EXPLODED VIEW & PARTS LIST -----	20-21
GLOWPLUG -----	10	CARBURETOR EXPLODED VIEW & PARTS LIST -----	22
TOOLS, ACCESSORIES, etc. -----	11-12	O.S. GENUINE PARTS & ACCESSORIES -----	23-24
CARBURETOR CONTROLS -----	12	THREE VIEW DRAWING -----	25
STARTING THE ENGINE & RUNNING-IN ('Breaking-in') -----	13-14	MEMO -----	26
IF THE ENGINE FAILS TO START -----	15		
FINAL ADJUSTMENT -----	15-16		

SAFETY INSTRUCTIONS AND WARNINGS ABOUT YOUR O.S. ENGINE

Remember that your engine is not a "toy", but a highly efficient internal-combustion machine whose power is capable of harming you, or others, if it is misused.

As owner, you, alone, are responsible for the safe operation of your engine, so act with discretion and care at all times.

If at some future date, your O.S. engine is acquired by another person, we would respectfully request that these instructions are also passed on to its new owner.

■ The advice which follows applies basically to ALL MODEL ENGINES and is grouped under two headings according to the degree of damage or danger which might arise through misuse or neglect.



WARNINGS

These cover events which might involve serious (in extreme circumstances, even fatal) injury.



NOTES

These cover the many other possibilities, generally less obvious sources of danger, but which, under certain circumstances, may also cause damage or injury.



WARNINGS

• Model engine fuel is poisonous. Do not allow it to come into contact with the eyes or mouth. Always store it in a clearly marked container and out of the reach of children.



• Model engine fuel is also highly flammable. Keep it away from an open flame, excessive heat, sources of sparks, or anything else which might ignite it. Do not smoke or allow anyone else to smoke, near to it.



• Never operate your engine in an enclosed space. Model engines, like automobile engines, exhaust deadly carbon-monoxide. Run your engine only in an open area.

• Model engines generate considerable heat. Do not touch any part of your engine until it has cooled. Contact with the muffler (silencer), cylinder head or exhaust header pipe, in particular, may result in a serious burn.





NOTES

- This engine is intended for model cars. Do not attempt to use it for any other purpose.
- Mount the engine in your model securely, following the manufacturers' recommendations, using appropriate screws and locknuts.
- Install an effective silencer (muffler). Frequent close exposure to a noisy exhaust (especially in the case of the more powerful highspeed engines) may eventually impair your hearing and such noise is also likely to cause annoyance to others over a wide area.
- The wearing of safety glasses is also strongly recommended.
- Take care that the glowplug clip or battery leads do not come into contact with rotating parts. Also check that the linkage to the throttle arm is secure.
- For their safety, keep all onlookers (especially small children) well back (at least 20 feet or 6 meters) when preparing your model for running.



NOTES

- To stop the engine, fully retard the throttle stick and trim lever on the trans-mitter, or, in an emergency, cut off the fuel supply by pinching the fuel delivery line from the tank.
- Warning! Immediately after a glowplug-ignition engine has been run and is still warm, conditions sometimes exist whereby it is just possible for the engine to abruptly restart if it is rotated over compression WITHOUT the glowplug battery being reconnected.

The MAX-21VZ-B(P) is a high performance 3.5cc class power unit for one-eighth-scale radio-controlled 'off-road' or 'buggy' car. It has been designed to meet the exacting requirements of the world's most expert drivers.

Standard accessories

- Glow Plug A5 •Cylinder-head gasket (0.1mm)
- Exhaust Seal Ring •Dust Cap $\varnothing 3, \varnothing 16, \varnothing 18$
- Super Air Cleaner 203 Assembly

The engine is fit with one each of 0.1mm and 0.2mm cylinder-head gasket when it leaves the factory. Another 0.1mm head gasket is supplied with the engine. You may add it at initial running-in, when a glow plug tends to burn out due to high temperature and / or high humidity or when you prefer fuel economy to power.

NOTE

With this engine, the piston will feel tight at the top of its stroke when the engine is cold. This is normal. The piston and cylinder are designed to achieve a perfect running clearance when they reach their normal running temperatures.

BASIC ENGINE PARTS

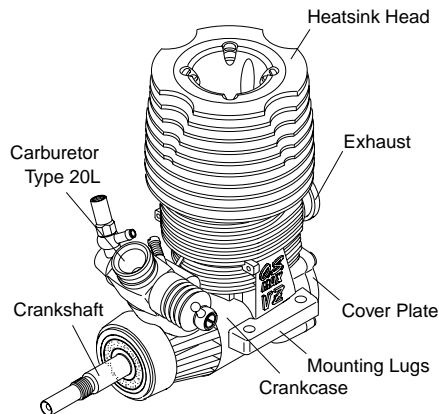

NOTE

As delivered, the engine has its carburetor lightly fit into its intake. Secure it changing its angle according to the car chassis.

INSTALLING THE GLOW PLUG AND EXHAUST SEAL RING

- Fit washer to glowplug and insert carefully into heatsink head, making sure that it is not cross-threaded before tightening firmly.
- Install the exhaust seal ring supplied.

INSTALLATION OF THE CARBURETOR

As delivered, the engine has its carburetor lightly install into its intake boss. Secure it as follows.

1. Loosen the retainer screw, rotate the carburetor to its correct position and make sure that it is pressed well down into the intake boss, compressing the rubber gasket, before retightening screw.

2. Rotate the retainer screw gently until it stops, then tighten a further 120-180°. Do not overtighten the screw as this will damage the carburetor body.

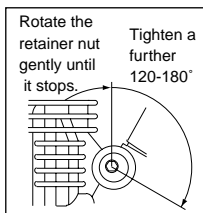

ENGINE INSTALLATION

Make sure that the vehicle's engine mounting surfaces are level and in the same plane. Poor installation may cause distortion of the crankcase, bearings, etc., resulting in erratic running and loss of performance.

The recommended screws for securing the engine are 3mm or 4-40 steel Allen hexagon socket type.

If existing holes in the engine mount do not align perfectly with engine mounting lugs, enlarge them slightly with a needle-file so that screws are in alignment with the mounting holes.

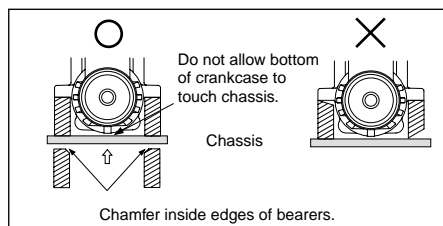

AIR CLEANER TYPE 203

This is a heavy-duty wet type air cleaner that has been developed specifically for 3.5cc 'off-road' model car engines. It is more compact than the former O.S. SUPER AIR CLEANER 202 and this makes it easier to install within a car body.

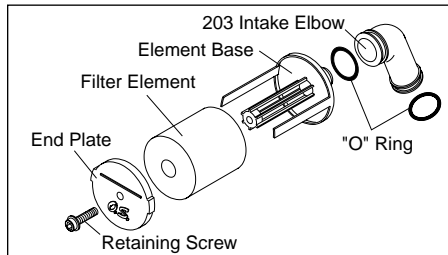

NOTE:

The element is already impregnated with a special filter oil. As this oil is very sticky, take care, when handling it, to prevent dust or dirt from adhering to the element. If your fingers become contaminated, wash them with soap and water.

ASSEMBLY

- Insert the filter element on the element base.
- Fit the end plate with retaining screw, making sure that the element fits correctly between the end plate and base.
- Insert the joint pipe on the element base and secure it with "O" ring.
- Fit the end plate, retaining screw, making sure that the element fits correctly between the end plate and base.

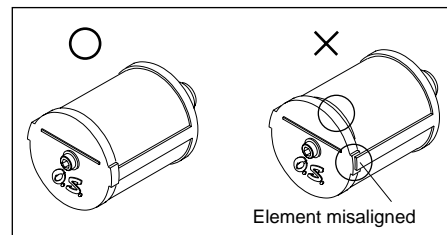

8

REPLACEMENT OF ELEMENT

NOTE:

During storage, the oil may have become unevenly dispersed through the element. This will be indicated if the blue colour of the element material appears patchy. In this case, place the element in a small plastic bag and gently rub the element between finger and thumb to redistribute oil.

- It is advisable to replace the filter element after each hour of running time. Be careful not to enter the dirt and dust into the carburetor.

INSTALLATION

- Carefully clean the carburettor, removing any old adhesive or sealant that may have been previously used on the outside of the air intake.

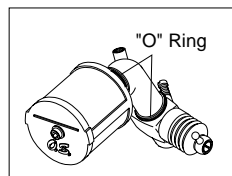

FURTHER PRECAUTIONS

When removing the air cleaner, check the inside of the element base and carburetor venturi. If any dirt is detected, this indicates that the filter element was incorrectly fitted or should have been replaced earlier. In this event, it is vitally important to wash out the inside of the engine thoroughly, with alcohol or fuel, before it is used again, otherwise rapid wear of the piston/cylinder assembly, bearings, connecting-rod, etc., will occur. Obviously, it will be necessary to carry out the same procedure with the air cleaner and to replace the filter element.

NOTE:

Be careful not to splash alcohol or fuel over the filter element, or the filter oil will be washed away, and the filter capacity will be lowered.

9

GLOWPLUG

Since the compatibility of glowplug and fuel may have a marked effect on performance and reliability, it may be worthwhile to choose the R/C type plug found most suitable after tests. Recommended O.S. plugs are A5 and No.8. Carefully install plug finger-tight, before final tightening with the correct size plug wrench.

The role of the glowplug

With a glowplug engine, ignition is initiated by the application of a 1.5-volt power source. When the battery is disconnected, the heat retained within the combustion chamber remains sufficient to keep the plug filament glowing, thereby continuing to keep the engine running. Ignition timing is 'automatic' : under reduced load, allowing higher rpm, the plug becomes hotter and, appropriately, fires the fuel/air charge earlier; conversely, at reduced rpm, the plug become cooler and ignition is retarded.

Glowplug life

Particularly in the case of very high performance engines, glowplugs must be regarded as expendable items. However, plug life can be extended and engine performance maintained by careful use, i.e.:

- Install a plug suitable for the engine.
- Use fuel containing a moderate percentage of nitromethane unless more is essential for racing events.
- Do not run the engine too lean and do not leave the battery connected while adjusting the needle.

When to replace the glowplug

Apart from when actually burned out, a plug may need to be replaced because it no longer delivers its best performance, such as when:

- Filament surface has roughened and turned white.
- Filament coil has become distorted.
- Foreign matter has adhered to filament or plug body has corroded.
- Engine tends to cut out when idling.
- Starting qualities deteriorate.

TOOLS, ACCESSORIES, etc.

The following items are necessary for operating the engine.

FUEL

Generally, it is suggested that the user selects a fuel that is commercially available for model two-stroke engines and contains 10-30% nitromethane. As a starting point, we recommend a fuel containing 20% nitromethane, changing to a fuel containing more nitro if necessary. When the brand of fuel is changed, or the nitro content increased, it is advisable to repeat the running-in procedure referred to in the RUNNING-IN paragraphs. Please note that with high-nitro fuels, although power may be increased for competition purposes, glowplug elements do not last as long and engine life will be shortened.

REMINDER!

! **Model engine fuel is poisonous. Do not allow it to come into contact with the eyes or mouth. Always store it in a clearly marked container and out of the reach of children.**

! **Model engine fuel is also highly flammable. Keep it away from open flame, excessive heat, sources of sparks, or anything else which might ignite it. Do not smoke or allow anyone else to smoke, near to it.**

BATTERY INTEGRATED GLOWPLUG HEATER

Commercially available handy glowplug heater in which the glowplug battery and battery leads are integrated.

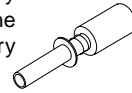

STARTER BOX

For starting the engine.

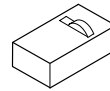

FUEL PUMP

For filling the fuel tank, a simple, polyethylene "squeeze" bottle, with a suitable spout, is required.



LONG SOCKET WRENCH

Recommended for easy removal and replacement of the angled and recessed glowplug, the O.S. Long Socket Wrench incorporates a special grip.

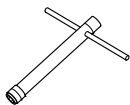

SILICONE FUEL LINE

Heatproof silicone tubing of approx. 5mm o.d. and 2mm i.d. is required for the connection between the fuel tank and engine.

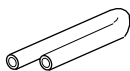

CARBURETOR CONTROLS

Four adjustable controls are provided on this carburetor.

- **The Needle-Valve:**
For adjusting the mixture strength when the throttle is fully open.
- **The Mixture Control Screw:**
For changing the feeling at mid speeds and acceleration. (Do not rotate the screw more than one turn.)

- **The Metering Needle:**

For adjusting the mixture strength at part-throttle and idling speeds, to obtain steady idling and smooth acceleration to mid speeds.

- **The Throttle Stop Screw:**

For setting the minimum idling speed:

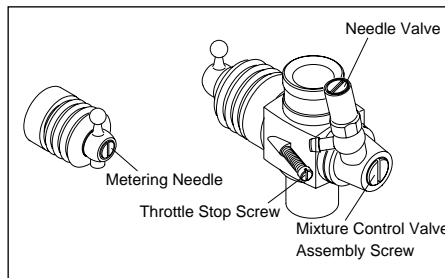

NOTE: Readjustment may be necessary, occasionally to allow for changes in fuel formula gear ratio or clutch engagement point.

STARTING THE ENGINE & RUNNING-IN ('Breaking-in')

For long life and high performance, every engine needs to be 'run-in' or 'broken-in'. With care, running-in of the MAX-21VZ-B(P) can be carried out with it installed in the vehicle. Be sure to fit the air-cleaner to the carburetor and to use a muffler-pressurized fuel system.

The following procedure is suitable for these engines when the O.S. T-2050 tuned silencer and a fuel containing up to 30% nitromethane are used.

- Use the same fuel as is to be employed for all initial running and containing NOT LESS THAN 18% lubricant.
- Temporarily remove the glowplug to check that it glows bright red when energized.
- Open the Needle-Valve 3 turns from the fully closed position.
- Switch on the transmitter and receiver and set the throttle very slightly opened from the idling position (see sketch, top right).
- DO NOT energize glowplug, but apply electric starter to draw fuel to carburetor.

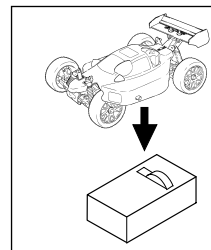
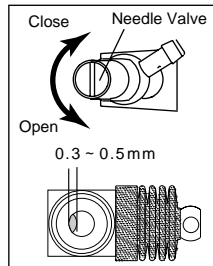

- Now connect glowplug battery lead to heat the plug filament and start the engine.

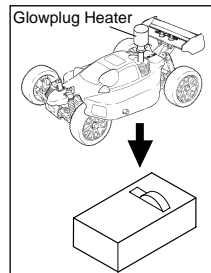

Attention:

It is vitally important to set the throttle at the correct position before starting the engine. If the engine is allowed to run under "no load" conditions (i.e. with the driving wheels not in contact with the ground) it will rapidly over-heat and may be seriously damaged.



- When the engine starts, first allow it to operate in short runs at the very rich starting settings, with the glowplug battery still connected and the driving wheels clear of the ground. The rich mixture will, under these conditions, provide adequate lubrication and cooling, indicated by profuse smoke from the exhaust.
- Next, disconnect the glowplug battery and try running the car on the track. If the engine stalls, open the throttle fractionally, but try to keep the engine running as rich as possible: if it stops because of being excessively over-rich, close the Needle-Valve 30° and try again.

- Run the car on the track until one tank of fuel has been consumed, then close the Needle-Valve 30° and run the car for another full tank of fuel. Repeat this procedure until 5 more tanks of fuel have been consumed, during which time the throttle may be opened for brief bursts of increased power.

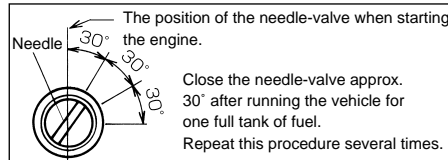

To stop the engine, close the throttle to idling speed, then shut it off completely with the trim lever on the transmitter. To cut off the fuel supply, pinch the fuel delivery line to the carburetor.

If the engine should need to be disassembled (e.g. for cleaning or minor parts replacement) it is advisable to return the Needle-Valve to the original rich, starting setting and check whether further running-in time is required before the car is raced again. In the event of any major working parts (e.g. piston/cylinder liner assembly) being replaced, the complete running-in should be repeated.

IF THE ENGINE FAILS TO START

Check the following:

- ◆ Glowplug battery discharged or glowplug defunct.
- ◆ Fuel not reaching carburetor.
- ◆ Engine flooded. Do not over-prime. (This could also cause hydraulic lock and damage the engine on application of the electric starter.) Remove glowplug, close needle-valve and apply starter to pump out surplus fuel.

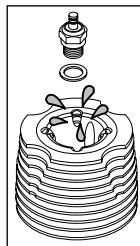

FINAL ADJUSTMENT

- ◆ Run the vehicle (with throttle fully open) over the longest available straight course, in order to observe the model's speed. Next return the car to the starting point, close the Needle-Valve 30° and repeat the run, taking note of the improvement in performance. Continue with further runs, gradually reducing the Needle-Valve setting and aiming to achieve the highest straight-line speed. Remember, however, that, if the Needle-Valve is shut down too far, the engine will overheat and, accompanied by visibly diminished exhaust smoke, the model will lose speed. At this point, throttle down immediately, stop the vehicle and reopen the Needle-Valve 45-90°.
- ◆ Having established the optimum Needle-Valve setting, check the Mixture Control Valve setting as follows.

- ◆ With the engine running, close the throttle and allow it to idle for about five seconds, then reopen the throttle fully.

If, at this point, the engine puffs out an excessive amount of smoke and the vehicle does not accelerate smoothly and rapidly, it is probable that the idling mixture is too rich.

In this case, turn the Metering Needle clockwise 45-90°. If, on the other hand, the engine tends to speed up momentarily and then cut out abruptly when the throttle is opened, the idling mixture is too lean. Correct this by turning the Metering Needle counter-clockwise 45-90°.

NOTE:

Metering Needle adjustment should be made in steps of not more than 45-90°, carefully checking the effect, on throttle response, of each small adjustment.

- ◆ Carry out adjustments patiently, under actual running conditions, until the engine responds quickly and positively to the throttle control.

Warning!

Mixture adjustments (whether via the Metering Needle, or the Needle-Valve) cannot be made accurately under 'no-load' conditions, which, in any case, are not advised, since such operation carries the risk of seriously damaging the engine through over-revving and overheating.

- ◆ With the optimum mixture control position, light smoke is visible during high speed running, and the engine revolutions increase smoothly during acceleration. Remember that, if the engine is operated with the fuel/air mixture slightly too lean, it will overheat and run unevenly. As with all engines, it is advisable to set both the needle-valve and metering needle very slightly on the rich side of the best rpm setting, as a safety measure.
- ◆ If the engine runs too fast with the throttle closed, the throttle stop screw should be turned counter-clockwise to allow the throttle opening to be reduced.
- ◆ Finally, beyond the nominal break-in period, a slight readjustment toward a leaner needle setting may be required to maintain performance.

CARBURETOR CLEANLINESS

The correct functioning of the carburetor depends on its small fuel orifices remaining clear.
(See Care and Maintenance section on Page 19.)

REALIGNMENT OF METERING NEEDLE AND MIXTURE CONTROL VALVE

In the course of making carburetor adjustments, it is just possible that the Metering Needle and the Mixture Control Valve may be inadvertently screwed in or out too far and thereby moved beyond its effective adjustment range.

Its basic position can be found by rotating the Metering Needle and Mixture Control Valve until its slotted head is flush with ball link the carburetor body.

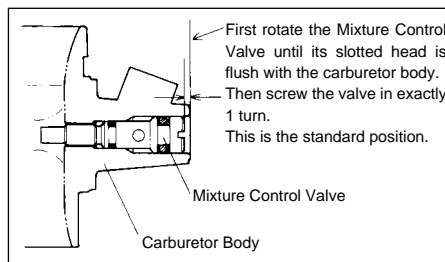
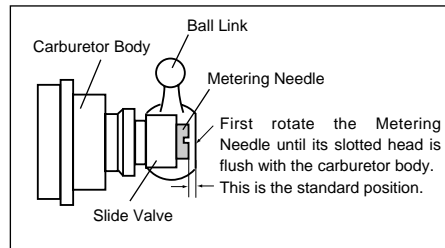

BEFORE STARTING THE ENGINE

1. Before starting the engine for the first run of the day, remove the glowplug and check the engine by rotating the flywheel by hand. It should rotate smoothly. Now turn the engine with an electric starter until fuel is drawn into the carburetor. At first, rotation may feel 'sticky' due to oily residue remaining within the engine. The engine should rotate freely after fresh fuel has been drawn into the working parts.
2. Check the glowplug. If the plug element is distorted, off center, or has a white appearance, engine performance may be below par. With racing type engines, glowplugs have to be regarded as expendable items. Therefore, replace the plug if necessary.
3. Reinstall the glowplug and start the engine.
4. When re-starting the engine, turn the flywheel by hand, as before (but without removing the glowplug) to make sure that there is nothing unusual, before energising the glowplug and applying the starter.

Warning!

Do not attempt to turn the engine with the starter if the engine is over-primed (flooded) with fuel. To do so is likely to seriously damage the engine.

CARE AND MAINTENANCE

1. The minute particles of foreign matter, that are present in any fuel may, by accumulating and partially obstructing fuel flow, cause engine performance to become erratic and unreliable. O.S. 'Super-Filters' (large and small) are available, as optional extras, to deal with this problem. One of these filters installed to the outlet tube inside your refueling container, will prevent the entry of foreign material into the fuel tank. It is also recommended that a good in-line filter be installed between the tank and carburetor.
2. Do not forget to clean the filters regularly to remove dirt and lint that accumulate on the filter screens. Also, clean the carburetor itself occasionally.
3. At the end of each operating session, drain out any fuel that may remain in the fuel tank. Afterwards, energize the glow-plug and try to restart the engine, to burn off any fuel that may remain

inside the engine. Repeat this procedure until the engine fails to fire. Do this while the engine is still warm.

4. Then, inject some after-run oil into the engine, and rotate the engine with an electric starter for 4 to 5 seconds to distribute the oil to all the working parts.

Note:

Do not inject after-run oil into the carburetor as this may cause the O-rings inside the carburetor to deteriorate. These procedures will reduce the risks of starting difficulties or corrosion after a period of storage.

5. Finally, when cleaning the exterior of the engine, use methanol or kerosene. Do not use gasoline or any solvent that might damage the silicone fuel tubing.

Caution:

The rear crankshaft bearing of this engine uses a special plastic retainer. If the front housing needs to be heated to remove or replace the bearing, do not allow the bearing to exceed 120°C (248°F), otherwise it may be damaged and rendered unserviceable.

GUARANTEE

This engine is constructed from the very best materials available and to the very highest engineering standards, using the most advanced precision machinery. However, the extremely high stresses imposed by car racing operation under very severe conditions, stresses which are exacerbated by the use of powerful fuels containing very high concentrations of nitromethane, constitute hazards which are beyond a manufacturer's control. Accordingly, we regret that it is not possible to extend our usual warranty terms to this particular engine -i.e. no guarantee is offered against material wear, or damage resulting therefrom, in actual use.

ENGINE EXPLODED VIEW

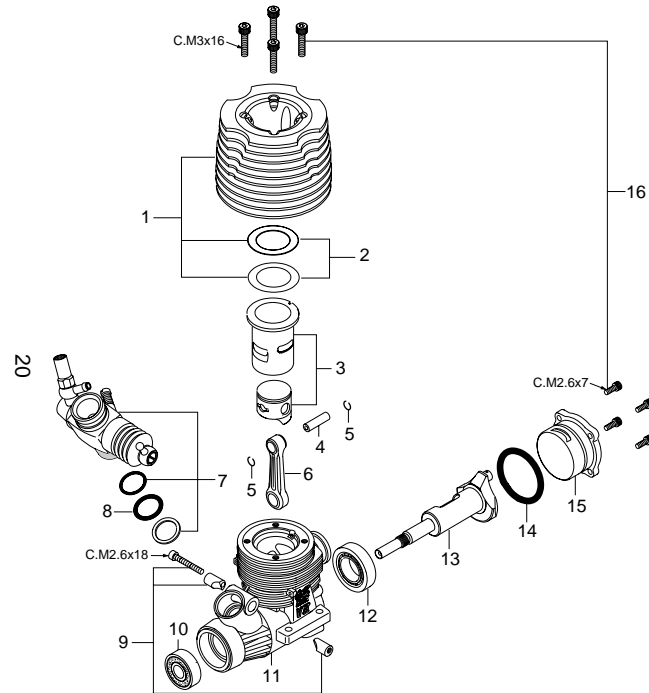

*Type of screw C...Cap Screw M...Oval Fillister-Head Screw
F...Flat Head Screw N...Round Head Screw S...Set Screw

ENGINE PARTS LIST

No.	Code No.	Description
1	22104000	Heatsink Head
2	23764010	Head Gasket
3	22103000	Cylinder & Piston Assembly
4	23906000	Piston Pin
5	23817000	Piston Pin Retainer (2pcs.)
6	23755000	Connecting Rod
7	22181000	Carburetor Complete (Type 20L)
8	23715000	Carburetor Sealing Gasket
9	23981700	Carburetor Retainer Assembly
10	23731000	Crankshaft Ball Bearing (Front)
11	22101000	Crankcase
12	23730010	Crankshaft Ball Bearing (Rear)
13	22102000	Crankshaft
14	23764020	Cover Gasket
15	23757000	Cover Plate
16	23763000	Screw Set
	71605100	Glow Plug A5
	22826140	Exhaust Seal Ring
	72413000	Super Air Cleaner 203 Assembly
	72413200	203 Filter Elements (4pcs.)
	22884250	Dust Cap Set (∅3, ∅16, ∅18)

The specifications are subject to alteration for improvement without notice.

CARBURETOR EXPLODED VIEW & PARTS LIST

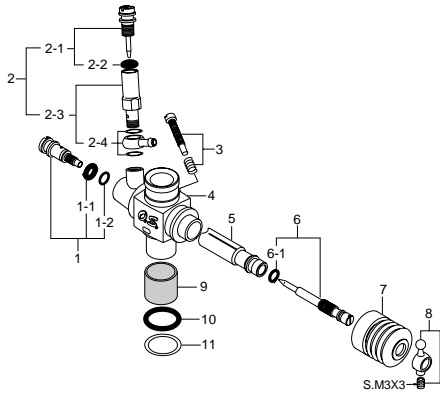

No.	Code No.	Description
1	23781600	Mixture Control Valve Assembly
1-1	46066319	"O" Ring (L) (2pcs.)
1-2	22781800	"O" Ring (S) (2pcs.)
2	23618190	Needle Valve Assembly
2-1	23618197	Needle Assembly
2-2	46066319	"O" Ring (2pcs.)
2-3	23618194	Needle Holder Assembly
2-4	23818176	Fuel Inlet (No.9)
3	23818500	Throttle Stop Screw
4	22181100	Carburetor Body (w/Thermo Insulator)
5	22181200	Slide Valve
6	22181600	Metering Needle Assembly
6-1	27881820	"O" Ring (2pcs.)
7	22884220	Dust Cover
8	23781400	Ball Link No.3
9	23781110	Thermo Insulator
10	29015019	Carburetor Rubber Gasket
11	23818190	Carburetor Sealing Washer

*Type of screw

C...Cap Screw M...Oval Fillister-Head Screw

F...Flat Head Screw N...Round Head Screw S...Set Screw

The specifications are subject to alteration for improvement without notice.

O.S. SPEED
RACING ENGINE PARTS

O.S. GENUINE PARTS & ACCESSORIES

■ GLOWPLUG

A5

(71605100)

No.8

(71608001)

■ T-2030 TUNED SILENCER

(72106030)

■ 21RZ EXHAUST

HEADER PIPE (72101270)

■ T-2050 TUNED SILENCER

ASSEMBLY (72106060)

- T-2050 Tuned Silencer Body (72106061)

· Pressure Nipple (72106041)

- Exhaust Seal Ring (2pcs.) (22826140)

- Joint Spring (3pcs.) (72106042)

■ T-2050 EXHAUST HEADER PIPE

ASSEMBLY (72106150)

- Exhaust Header Pipe (72106155)

- Header Pipe Spring (2pcs.) (72101272)

- Exhaust Seal Ring (2pcs.) (22826140)

■ T-2050 TUNED SILENCER COMPLETE SET (72106070)

- T-2050 Tuned Silencer Assembly (72106060)

- T-2050 Exhaust Header Pipe Assembly (72106150)

■ T-2040 TUNED SILENCER ASSEMBLY (72106040)

- T-2040 Tuned Silencer Body (72106043)

· Pressure Nipple (72106041)

- Exhaust Seal Ring (2pcs.) (22826140)

- Joint Spring (3pcs.) (72106042)

■ T-2040 EXHAUST HEADER PIPE ASSEMBLY (72106140)

- Exhaust Header Pipe (72106141)

- Header Pipe Spring (2pcs.) (72106142)

- Exhaust Seal Ring (2pcs.) (22826140)

The specifications are subject to alteration for improvement without notice.

■ **T-2040 TUNED SILENCER COMPLETE SET** (72106050)

- T-2040 Tuned Silencer Assembly (72106040)
- T-2040 Exhaust Header Pipe Assembly (72106140)

■ **SUPER JOINT TUBE 21** (72106300)

■ **EXHAUST SEAL RING** (2pcs.) (22826140)

■ **SUPER AIR CLEANER 203** (72413000)

- 203 Filter Element (4pcs.) (72413200)

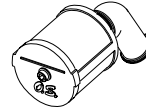

■ **DUST CAP SET**

- ø **3** (5pcs.) (73300305)
- ø **8** (3pcs.) (73300812)
- ø **16** (3pcs.) (73301612)
- ø **18** (3pcs.) (73301812)

■ **CAP SCREW SET**

- M2.6x7** (10pcs.) (79871020)

■ **CRANKSHAFT CLAMP 1521** (71530200)

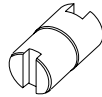

■ **LONG SOCKET WRENCH WITH PLUG GRIP** (71521000)

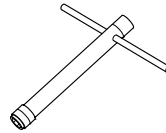

The specifications are subject to alteration for improvement without notice.

THREE VIEW DRAWING

SPECIFICATIONS

■ Displacement	3.46cc (0.211cu.in.)
■ Bore	16.6mm (0.654in.)
■ Stroke	16.0mm (0.630in.)
■ Practical R.P.M.	3,000-40,000 r.p.m.
■ Power output	2.45ps / 32,000 r.p.m.
■ Weight	340g (12oz.)

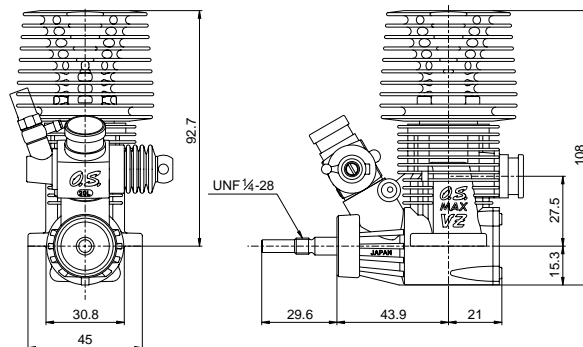
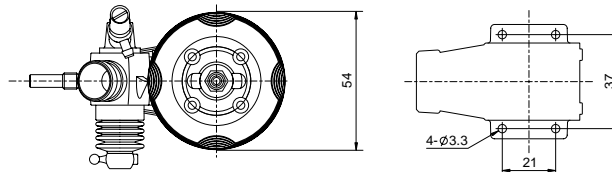

Dimensions (mm)

MEMO



O.S. ENGINES MFG. CO., LTD.

6-15 3-Chome Imagawa Higashisumiyoshi-ku
Osaka 546-0003, Japan TEL. (06) 6702-0225

FAX. (06) 6704-2722

URL : <http://www.os-engines.co.jp>