

OWNER'S INSTRUCTION MANUAL

It is of vital importance, before attempting to operate your engine, to read the general **'SAFETY INSTRUCTIONS AND WARNINGS'** section on pages 2-5 of this booklet and to strictly adhere to the advice contained therein.

- Also, please study the entire contents of this instruction manual, so as to familiarize yourself with the controls and other features of the engine.
- Keep these instructions in a safe place so that you may readily refer to them whenever necessary.
- It is suggested that any instructions supplied with the vehicle, radio control equipment, etc., are accessible for checking at the same time.

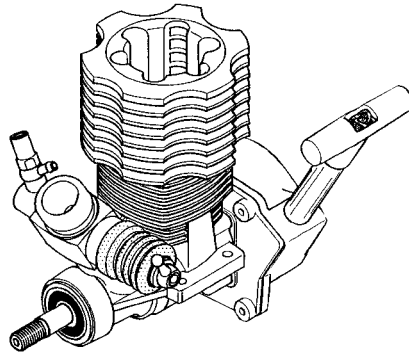

CONTENTS

SAFETY INSTRUCTIONS AND WARNINGS ABOUT YOUR O.S. ENGINE -----	2-5	IF THE ENGINE FAILS TO START -----	18
INTRODUCTION, BASIC ENGINE PARTS-----	6	FINAL ADJUSTMENT -----	18-19
INSTALLATION OF THE ENNGINE -----	7-8	CARBURETOR CLEANLINESS -----	20
INSTALLATION OF THE CARBURETOR -----	8	BEFORE STARTING THE ENGINE -----	21
AIR CLEANER TYPE201 -----	9-12	CARE AND MAINTENANCE -----	21-22
NOTES CONCERNING THE RECOIL STARTER -----	12	GUARANTEE -----	22
GLOWPLUG -----	13	O.S. GENUINE PARTS & ACCESSORIES -----	23
TOOLS, ACCESSORIES, etc. -----	13-14	ENGINE EXPLODED VIEW & ENGINE PARTS LIST -----	24-27
CARBURETOR CONTROLS, PRESSURIZED FUEL SYSTEM -----	15	CARBURETOR EXPLODED VIEW & PARTS LIST -----	28-29
STARTING THE ENGINE & RUNNING-IN('Breaking-in) -----	15-18	THREE VIEW DRAWING -----	30

SAFETY INSTRUCTIONS AND WARNINGS ABOUT YOUR O.S. ENGINE

Remember that your engine is not a "toy", but a highly efficient internal-combustion machine whose power is capable of harming you, or others, if it is misused.

As owner, you, alone, are responsible for the safe operation of your engine, so act with discretion and care at all times.

If at some future date, your O.S. engine is acquired by another person, we would respectfully request that these instructions are also passed on to its new owner.

■ The advice which follows applies basically to ALL MODEL ENGINES and is grouped under two headings according to the degree of damage or danger which might arise through misuse or neglect.



WARNINGS

These cover events which might involve serious (in extreme circumstances, even fatal) injury.



NOTES

These cover the many other possibilities, generally less obvious sources of danger, but which, under certain circumstances, may also cause damage or injury.

2



WARNINGS

• Model engine fuel is poisonous. Do not allow it to come into contact with the eyes or mouth. Always store it in a clearly marked container and out of the reach of children.



• Model engine fuel is also highly flammable. Keep it away from open flame, excessive heat, sources of sparks, or anything else which might ignite it. Do not smoke or allow anyone else to smoke, near to it.



• Never operate your engine in an enclosed space. Model engines, like automobile engines, exhaust deadly carbon-monoxide. Run your engine only in an open area.

• Model engines generate considerable heat. Do not touch any part of your engine until it has cooled. Contact with the muffler (silencer), cylinder head or exhaust header pipe, in particular, may result in a serious burn.



3



NOTES

- This engine is intended for model cars. Do not attempt to use it for any other purpose.
- Mount the engine in your model securely, following the manufacturers' recommendations, using appropriate screws and locknuts.
- Fit an effective silencer (muffler). Frequent close exposure to a noisy exhaust (especially in the case of the more powerful highspeed engines) may eventually impair your hearing and such noise is also likely to cause annoyance to others over a wide area.
- The wearing of safety glasses is also strongly recommended.
- Take care that the glowplug clip or battery leads do not come into contact with rotating parts. Also check that the linkage to the throttle arm is secure.
- For their safety, keep all onlookers (especially small children) well back (at least 20 feet or 6 meters) when preparing your model for running.



NOTES

- To stop the engine, fully retard the throttle stick and trim lever on the trans-mitter, or, in an emergency, cut off the fuel supply by pinching the fuel delivery tube from the tank.
- Do not attempt to disassemble the recoil starter. If you do so, the very strong spring inside will be suddenly ejected. This can be very dangerous.
- Do not extend the starter cord more than 45cm (18"). Do not abruptly release the operating handle. Allow the cord to rewind smoothly while still holding the handle.
- Pull the operating handle straight out when starting the engine, so that the cord does not rub against the vehicle body or engine. This will help prevent the cord from being damaged by abrasion or engine heat.
- Warning! Immediately after a glowplug-ignition engine has been run and is still warm, conditions sometimes exist whereby it is just possible for the engine to abruptly restart if it is rotated over compression WITHOUT the glowplug battery being reconnected.

The MAX-21RG Series has been developed for 1/8 scale off-road 'buggy' and scale cars. It provides a combination of performance and value that brings it within the reach of a larger group of R/C model vehicle enthusiasts, from newcomers to experienced competitors. All major parts of the MAX-21RG have been redesigned. Its potential is very close to that of the top-ranking MAX-21RZ motors, but it remains easy to operate and is considerably less expensive. The MAX-21RG has a conventional crankshaft, while the MAX-21RG(P) employs a special crankshaft with integral pilot shaft. The MAX-21RG-X and MAX-21RG(P)-X have the addition of a built-in O.S. recoil starting system. The starter unit eliminates the need for a separate electric starter and battery.

NOTE: With this engine, the piston will feel tight at the top of its stroke when the engine is cold. This is normal. The piston and cylinder are designed to achieve a perfect running clearance when they reach their normal running temperatures.

BASIC ENGINE PARTS

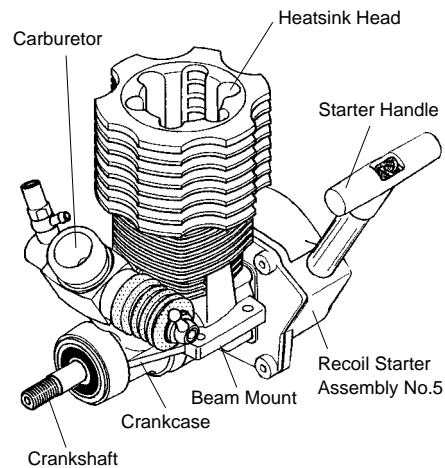

MAX-21RG-X

6

INSTALLING THE GLOWPLUG

Install the washer on the glowplug and insert carefully into cylinder-head, making sure that it is not cross-threaded before tightening firmly.

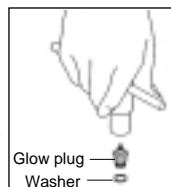

ENGINE INSTALLATION

Make sure that the vehicle's engine mounting surfaces are level and in the same plane. Poor installation may cause distortion of the crankcase, bearings, etc., resulting in erratic running and loss of performance. The recommended screws for securing the engine are 3mm or 4-40 steel Allen hexagon socket type. If existing holes in the engine mount do not align perfectly with engine mounting lugs, enlarge them slightly with a needle-file so that screws align with the mounting holes.

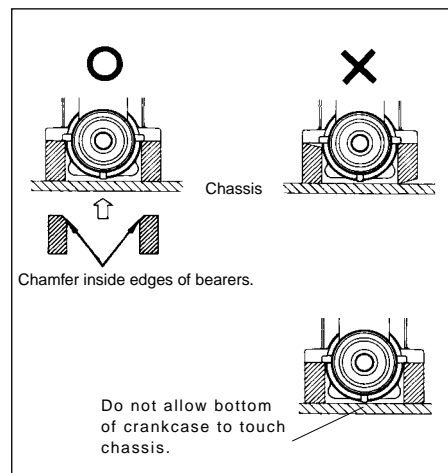

7

Avoid forcing the screws. Secure with locknuts. If the bottom of the recoil starter housing touches the car chassis, install the engine mount spacers (supplied) between the engine's mounting lugs and the engine mount. Use the M3x15 screws provided. With some vehicles, it may be necessary to make minor trimming modifications to chassis or body when fitting the engine.

NOTE:
Where spacers are supplied joined in pairs (see sketch) separate them as shown.
Either face may be placed downwards.

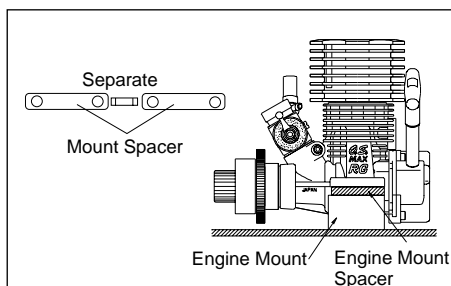

INSTALLATION OF THE CARBURETOR

As delivered, the engine has its carburetor lightly fitted into its intake boss. Secure it as follows.

1. Loosen the retainer screw, rotate the carburetor to its correct position and make sure that it is pressed well down into the intake boss, compressing the rubber gasket, before retightening screw.
2. Rotate the retainer screw gently until it stops, then tighten a further 90-120°. Do not overtighten the screw as this will damage the carburetor body.

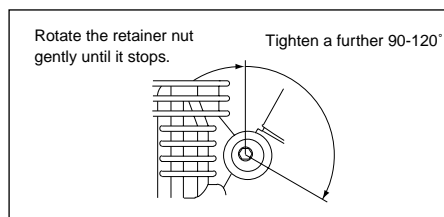

8

AIR CLEANER TYPE 201

This is a heavy-duty wet type air cleaner that has been developed specifically for 3.5cc 'off-road' model car engines. It contains a specially impregnated filter element which more positively prevents highly damaging dust and dirt from being drawn through the carburetor, yet allows engine performance to be maintained for longer periods between element renewals. It is more compact than the standard O.S. HD Air Cleaner and this makes it easier to install within a car body. This air cleaner is also supplied with a newly designed intake elbow that provides more secure attachment to the carburetor.

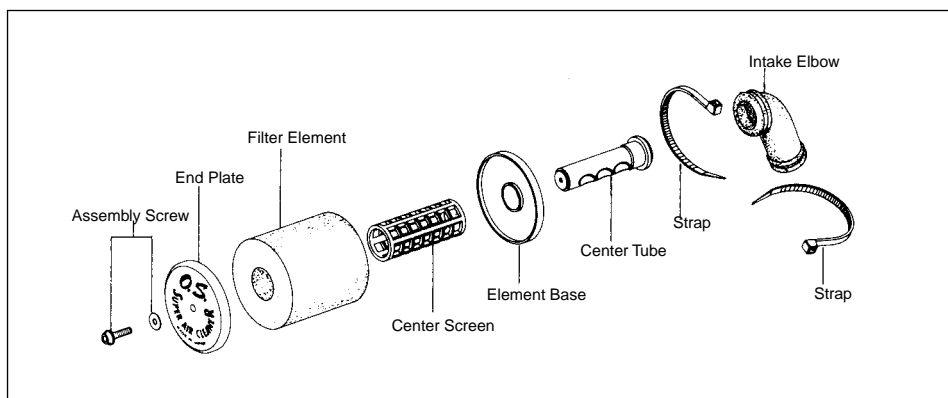

9

ASSEMBLY

- Slide the element base over the center tube (See Fig.1) and press down.
 - If it is tight at the bottom, apply one or two drops of fuel at the point marked in Fig.2
 - Press down near the center (not the outside) to avoid risk of breaking the element base.
 - Apply pressure until the element base fits firmly against the collar of the center tube (Fig.3).

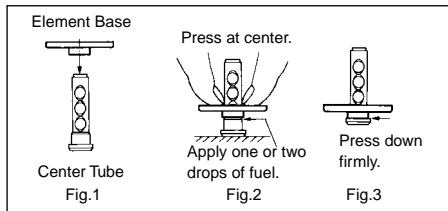

2. Installing the element.

- The element is already impregnated with a special filter oil. As this oil is very sticky, take care, when handling it, to prevent dust or dirt adhering to the element, especially to its inner surface before insertion of the center screen.

If your fingers become contaminated, wash them with soap and water.

NOTE: During storage, the oil may have become unevenly dispersed through the element. This will be indicated if the blue color of the element material appears patchy. In this case, place the element in a small plastic bag and gently rub the element between finger and thumb to redistribute the oil.

- Now insert the cylindrical center screen into the element, followed by the center tube. Do not, at anytime, omit the screen: it is essential for releasing air to the engine evenly.
- Fit the end plate, washer and retaining screw, making sure that the element fits correctly between the end plate and base.

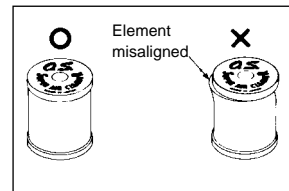

10

INSTALLATION

- Apply instant setting glue to the joint between the air cleaner and the intake elbow and secure with strap supplied.
 - Do not apply glue to carburettor.
- Fit the other end of the elbow over the carburettor intake and secure with strap supplied. Do not use glue at this point.
- It is advisable to brace the outer end of the air cleaner to the car chassis with a piano wire strut. This will restrain the cleaner in the event of the vehicle overturning or being involved in a collision.

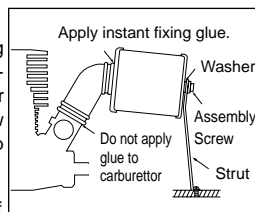

REPLACEMENT OF ELEMENT

- Under very dusty conditions, it is advisable to replace the filter element after each hour of running time.
- Under less severe conditions, however, it may be possible to operate for longer periods. The rate at which the elements become unusable may be determined as follows.

- After one hour of running time, remove the element but, before discarding it, check the penetration of foreign matter by cutting through the wall of the element. If dirt has penetrated 1/3rd or more from the outer surface, each element must always be replaced within one hour, when the vehicle is run under similar conditions. If, on the other hand, the element is much less deeply soiled, the engine may be run a little longer before another new element is installed, but remember to check the condition of the discarded element, as before. If the old element is examined in this way every time a new element is fitted, one can more closely estimate the safe life of the element under known running conditions.

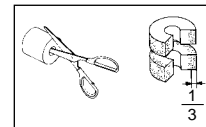

- Remember that the condition of the filter element will depend on weather, as well as track conditions. If, for example, the element surface is still visible and remains moist, further running is permissible.
- If, however, the surface is no longer visible, or if dust adhering to the surface has become dry, it is time to replace the element.

11

FURTHER PRECAUTIONS

When removing the air cleaner, check the inside of the center tube and carburetor venturi. If any dirt is detected, this indicates that the filter element was incorrectly installed or should have been replaced earlier. In this event, it is vitally important to wash out the inside of the engine thoroughly, with alcohol or fuel, before it is used again, otherwise rapid wear of the piston, cylinder, bearings, connecting-rod, etc., will occur. Obviously, it will be necessary to carry out the same procedure with the air cleaner and to replace the filter element.

NOTE: Be careful not to splash alcohol or fuel over the filter element, or the filter oil will be diluted, and the filter capacity lowered.

NOTES CONCERNING THE RECOIL STARTER

REMINDER!

Do not attempt to disassemble the recoil starter. If you do so, the very strong spring inside will be suddenly ejected. This can be very dangerous.

Do not extend the starter cord more than 45cm(18"). Do not abruptly release the operating handle. Allow the cord to rewind smoothly while still holding the handle.

Pull the operating handle straight out when starting the engine, so that the cord does not rub against the vehicle body or engine.

This will help prevent the cord from being damaged by abrasion or engine heat.

Try to avoid spilling fuel over the starter unit and its cord. Some fuels have a detrimental effect on these parts.

The starter prevents the engine from being rotated in the wrong direction. The unit will be damaged if you attempt to force the flywheel in the opposite direction (i.e. clockwise when viewed from the crankshaft end).

NOTE:

Because, in the interests of personal safety, dismantling of the starter mechanism is strongly discouraged, the Recoil Starter is available for replacement only as a pre-assembled unit.

However, some related parts, such as Starting Shaft and Rear Adaptor, are obtainable separately. (See Parts List.)

12

GLOWPLUG

Since the glowplug and fuel combination used may have a marked effect on performance and reliability, it would be worthwhile to experiment with different plug types. An O.S. No.8 glowplug is supplied with the engine. Other Recommended O.S. plugs are A3 and A5. Carefully install plug finger-tight, before final tightening with the correct size plug wrench.

The role of the glowplug

With a glowplug engine, ignition is initiated by the application of a 1.5-volt power source. When the battery is disconnected, the heat retained within the combustion chamber remains sufficient to keep the plug filament glowing, thereby continuing to keep the engine running. Ignition timing is 'automatic' : under reduced load, allowing higher rpm, the plug becomes hotter and, appropriately, fires the fuel/air charge earlier; conversely, at reduced rpm, the plug becomes cooler and ignition is retarded.

Glowplug life

Particularly in the case of very high performance engines, glowplugs must be regarded as expendable items. However, plug life can be extended and engine performance maintained by careful use, i.e.:

- Install a plug suitable for the engine.
- Use fuel containing a moderate percentage of nitromethane unless more is essential for racing events.
- Do not run the engine too lean and do not leave the battery connected while adjusting the needle.

When to replace the glowplug

Apart from when actually burned out, a plug may need to be replaced because it no longer delivers its best performance, such as when:

- Filament surface has roughened and turned white.
- Filament coil has become distorted.
- Foreign matter has adhered to filament or plug body has corroded.
- Engine tends to cut out when idling. Starting qualities deteriorate.

TOOLS, ACCESSORIES, etc.

The following items are necessary for operating the engine.

FUEL

Generally, it is suggested that the user selects a fuel that is commercially available for model two-stroke engines

13

and contains between 10% and 30% nitromethane. As a starting point, we recommend a fuel containing 10% nitromethane, changing to a fuel containing more nitro if necessary. When the brand of fuel is changed, or the nitro content increased, it is advisable to repeat the running-in procedure referred to in the RUNNING-IN paragraphs. For consistent performance and long engine life, it is essential to use a good quality fuel containing NOT LESS THAN 18% lubricant. Please note that with high-nitro fuels, although power may be increased for competition purposes, glowplug elements do not last so long and engine life will be shortened.

Reminder!

Model engine fuel is poisonous. Do not allow it to come into contact with the eyes or mouth. Always store it in a clearly marked container and out of the reach of children.



Model engine fuel is also highly flammable. Keep it away from open flame, excessive heat, sources of sparks, or anything else which might ignite it.



GLOWPLUG BATTERY

The power source for heating the glowplug may be either a large heavy-duty 1.5Volt dry cell, or a 2-Volt rechargeable

lead-acid cell with extended leads (or a resistance) to reduce the applied voltage to approximately 1.5-V.

BATTERY LEADS

These are used to conduct current from the battery to the glowplug. For convenience, special leads with a suitable clip to fit the glowplug terminal, are commercially available.

LONG SOCKET WRENCH

Recommended for easy removal and replacement of the angled and recessed glowplug, the O.S. Long Socket Wrench incorporates a special grip.

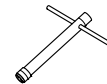

FUEL BOTTLE OR PUMP

For filling the fuel tank, a simple, polyethylene "squeeze" bottle, with a suitable spout, is required.



ELECTRIC STARTER AND STARTER BATTERY

Use an electric starter with 12-volt battery for starting the MAX-21RG/RG(P).



SILICONE FUEL LINE

Heatproof silicone fuel line of approx. 5mm o.d. and 2mm bore is required for the piping between the fuel tank and engine.

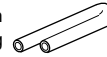

CARBURETOR CONTROLS

Three adjustable controls are provided on this carburetor.

- **The Needle-Valve:**
For adjusting the mixture strength when the throttle is fully open.
- **The Mixture Control Screw:**
For adjusting the mixture strength at part-throttle and idling speeds, to obtain steady idling and smooth acceleration to mid speeds.
- **The Throttle Stop Screw:**
For setting the minimum idling speed:

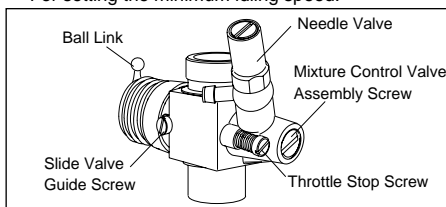

NOTE: Readjustment may be necessary, occasionally to allow for changes in fuel formula, gear ratio or clutch engagement point.

PRESSURIZED FUEL SYSTEM

- The somewhat violent changes of vehicle attitude that occur in off-road running, combined with the fact that, in buggy type cars, the fuel tank is often located some way from the carburetor, means that fuel 'head' at the carburetor can vary and upset running. Therefore, it is recommended that a muffler pressurized fuel feed system be used.
- Never run your vehicle without installing the air cleaner. Dust and dirt that may otherwise be drawn into the engine will rapidly shorten its life.

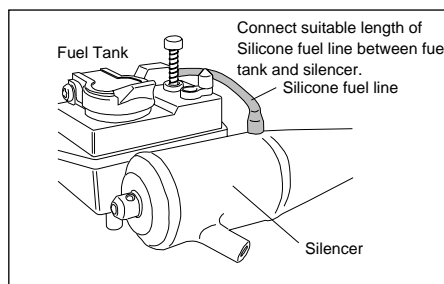

STARTING THE ENGINE & RUNNING-IN ('Breaking-in')

For long life and high performance, every engine needs to be properly 'run-in' or 'broken-in'. The running-in procedure for this engine can be carried out with the engine installed in the model. Be sure to use a muffler pressurized fuel system. The running-in procedure is as follows.

- Use the same fuel as is to be employed for all initial running and containing NOT LESS THAN 18% lubricant.

- Temporarily remove the glowplug to check that it glows bright red when energized.

- Re-check the needle-valve and throttle settings. Turn the needle-valve clockwise slowly and gently until it stops. This is the fully closed position. Do not use force to turn the needle-valve beyond this point.

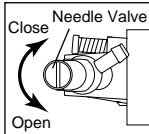

- Open the Needle-Valve 3 turns from the fully closed position.

- Switch on the transmitter and receiver and set the throttle very slightly opened from the idling position.

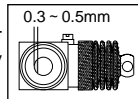

- DO NOT energize glowplug, but apply electric starter to draw fuel to carburetor.

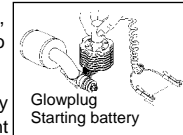

- Now connect glowplug battery lead to heat the plug filament and start the engine.

In case of the 21RG-X and 21RG(P)-X

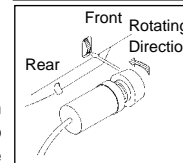

- Push the choke button on the fuel tank several times to deliver the fuel to the carburetor. (Do not over-prime or the recoil starter cannot be pulled.)

- Pull the starter handle briskly straight out several times to start the engine.

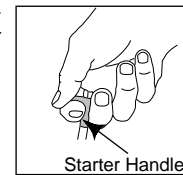

16

Remember!

It is vitally important to set the throttle at the correct position before attempting to start the engine. If the engine is allowed to run with the throttle too far open under "no load" conditions, it will rapidly overheat and may be seriously damaged.

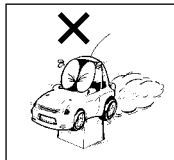

- When the engine starts, first allow it to operate in short runs on its very rich starting settings, with the glowplug battery still connected and with its driving wheels clear of the ground. The rich mixture will, under these conditions, provide adequate lubrication and cooling, indicated by profuse smoke from the exhaust.

- Next, disconnect the glowplug battery and try running the car on the track. If the engine stalls, open the throttle fractionally, but try to keep the engine running as rich as possible: if it stops because of being excessively over-rich, close the Needle-Valve 30° and try again.

- Run the car on the track until one tank of fuel has been consumed, then close the Needle-Valve 30° and run the car for another full tank of fuel.

Repeat this procedure until 5 more tanks of fuel have been consumed, during which time the throttle may be opened for brief bursts of increased power. If the engine stops at medium speeds, close the Mixture Screw 30°.

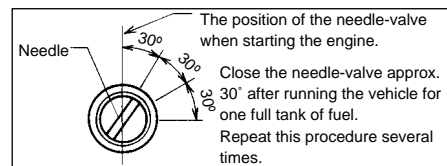

- To stop the engine, close the throttle to idling speed, then shut it off completely with the trim lever on the transmitter. To cut off the fuel supply, pinch the fuel delivery tube to the carburetor.

Remember!

If the engine should need to be disassembled (e.g. for cleaning or minor parts replacement) it is advisable to return the Needle-Valve to the original rich, starting setting and check whether further running-in time is required before the car is raced again. In the event of any major working parts (e.g. piston/cylinder liner assembly) being replaced, the complete running-in should be repeated.

17

IF THE ENGINE FAILS TO START

Check the following:

- Glowplug battery discharged or glowplug defunct.
- Fuel not reaching carburetor.
- Engine flooded. Do not over-prime. (This could also cause hydraulic lock and damage the engine on application of the electric starter.)

Remove glowplug, close needle-valve and apply starter to pump out surplus fuel. At this time cover the plug hole with a rag so that fuel will not splash into your eyes or mouth.

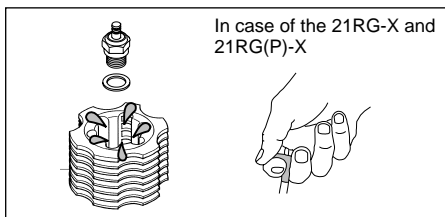

18

- In this case, turn the Mixture Control Valve clockwise 30°. If, on the other hand, the engine tends to speed up momentarily and then cut out abruptly when the throttle is opened, the idling mixture is too lean. Correct this by turning the Mixture Control Valve counter-clockwise 30–45°.

NOTE:

Mixture Control Valve adjustment should be made in steps of not more than 30–45°, carefully checking the effect, on throttle response, of each small adjustment.

- Carry out adjustments patiently, under actual running conditions, until the engine responds quickly and positively to the throttle control.

Warning!

Mixture adjustments (whether via the Mixture Control Valve, or the Needle-Valve) cannot be made accurately under 'no-load' conditions, which, in any case, are not advised, since such operation carries the risk of seriously damaging the engine through over-revving and overheating.

FINAL ADJUSTMENT

- Run the vehicle (with throttle fully open) over the longest available straight course, in order to observe the model's speed. Next return the car to the starting point, close the Needle-Valve 30° and repeat the run, taking note of the improvement in performance. Continue with further runs, gradually reducing the Needle-Valve setting and aiming to achieve the highest straight-line speed. Remember, however, that, if the Needle-Valve is shut down too far, the engine will overheat and, accompanied by visibly diminished exhaust smoke, the model will lose speed. At this point, throttle down immediately, stop the vehicle and reopen the Needle-Valve 30°.
- Having established the optimum Needle-Valve setting, check the Mixture Control Valve setting as follows.
- With the engine running, close the throttle and allow it to idle for about five seconds, then reopen the throttle fully. If, at this point, the engine puffs out an excessive amount of smoke and the vehicle does not accelerate smoothly and rapidly, it is probable that the idling mixture is too rich.

- With the optimum mixture control position, light smoke is visible during high speed running, and the engine revolutions increase smoothly during acceleration. Remember that, if the engine is operated with the fuel/air mixture slightly too lean, it will overheat and run unevenly. As with all engines, it is advisable to set both needle-valve and mixture control screw very slightly on the rich side of the best rpm setting, as a safety measure.

- If the engine runs too fast with the throttle closed, the throttle stop screw should be turned counter-clockwise to allow the throttle opening to be reduced.

- Finally, beyond the nominal break-in period, a slight readjustment toward a leaner needle setting may be required to maintain performance.

19

CARBURETOR CLEANLINESS

The correct functioning of the carburetor depends on its small fuel orifices remaining clear.
(See Care and Maintenance section on Page21.)

■ BALL LINK AND SLIDE VALVE EXTENSION

When readjusting the position of the Ball Link, always apply a 6mm spanner (wrench) to the flats in the Slide Valve Extension, before attempting to loosen or tighten the ball link retaining screw. Carefully ease back the Dust Cover bellows to allow access to the flats. If it should become necessary (e.g. for cleaning) to disassemble the throttle parts, first unscrew the Slide Valve guide screw and withdraw the complete sub-assembly from the carburetor body. Use the correct size (8mm) wrench when unscrewing the Slide Valve from the Slide Valve Extension.

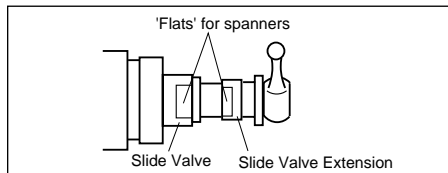

■ REALIGNMENT OF MIXTURE CONTROL VALVE

In the course of making carburetor adjustments, it is just possible that the Mixture Control Valve may be inadvertently screwed in or out too far and thereby moved beyond its effective adjustment range. Its basic position can be found by first rotating the Mixture Control Valve until its slotted head is flush with the carburetor body. The valve is then screwed in exactly 1 turn to re-establish its neutral position.

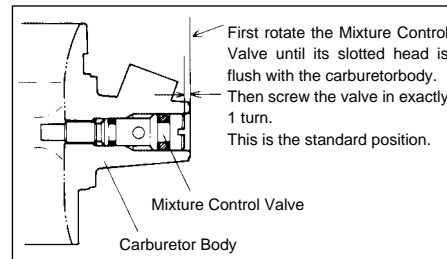

20

BEFORE STARTING THE ENGINE

1. Before starting the engine for the first run of the day, remove the glowplug and check the engine by rotating the flywheel by hand. It should rotate smoothly. Now turn the engine with an electric starter until fuel is drawn into the carburetor. At first, rotation may feel 'sticky' due to oily residue remaining within the engine. The engine should rotate freely after fresh fuel has been drawn into the working parts.
2. Check the glowplug. If the plug element is distorted, off-center, or has a white appearance, engine performance may be below par. With racing type engines, glowplugs have to be regarded as consumable items. Therefore, replace the plug if necessary.
3. Re-install the glowplug and start the engine.
4. When re-starting the engine, turn the flywheel by hand, as before (but without removing the glow-plug) to make sure that there is nothing unusual, before energising the glowplug and applying the starter.

Warning!

Do not attempt to turn the engine with the starter if the engine is over-primed (flooded) with fuel. To do so is likely to seriously damage the engine.

CARE AND MAINTENANCE

1. The minute particles of foreign matter, that are present in any fuel may, by accumulating and partially obstructing fuel flow, cause engine performance to become erratic and unreliable. O.S. 'Super-Filters' (large and small) are available, as optional extras, to deal with this problem. One of these filters, installed the outlet tube inside your refueling container, will prevent the entry of foreign material into the fuel tank. It is also recommended that a good in-line filter be installed between the tank and carburetor.
2. Do not forget to clean the filters regularly to remove dirt and lint that accumulate on the filter screens. Also, clean the carburetor itself occasionally.
3. At the end of each operating session, drain out any fuel that may remain in the fuel tank. Afterwards, energize the glow-plug and try to restart the engine, to burn off any fuel that may remain

21

inside the engine. Repeat this procedure until the engine fails to fire. Do this while the engine is still warm.

- Then, inject some after-run oil into the engine, and rotate the engine with an electric starter for 4 to 5 seconds to distribute the oil to all the working parts.

Note:

Do not inject after-run oil into the carburetor as this may cause the O-rings inside the carburetor to deteriorate. These procedures will reduce the risks of starting difficulties or corrosion after a period of storage.

- Finally, when cleaning the exterior of the engine, use methanol or kerosene. Do not use gasoline or any solvent that might damage the silicone fuel tubing.

Caution:

The rear crankshaft bearing of this engine uses a special plastic retainer. If the front housing needs to be heated to remove or replace the bearing, do not allow the bearing to exceed 120°C (248°F), otherwise it may be damaged and rendered unserviceable.

GUARANTEE

This engine is constructed from the very best materials available and to the very highest engineering standards, using the most advanced precision machinery. However, the extremely high stresses imposed by car racing operation under very severe conditions, stresses which are exacerbated by the use of powerful fuels containing very high concentrations of nitromethane, constitute hazards which are beyond a manufacturer's control. Accordingly, we regret that it is not possible to extend our usual warranty terms to this particular engine -i.e. no guarantee is offered against material wear, or damage resulting therefrom, in actual use.

O.S. SPEED O.S. GENUINE PARTS & ACCESSORIES RACING ENGINE PARTS

Drive Hub
(23908000)



No.8
(71608001)

A5
(71605100)

T-2030 Tuned Silencer
(72106030)



Exhaust Header Pipe For 21RG-X
(72103510)



Super Joint Tube 21
(72106300)



Crankshaft Clamp 1521
(71530200)

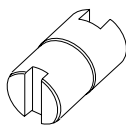

Long Socket Wrench With Plug Grip
(71521000)

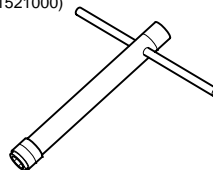

Cap Screw Set
(10pcs. set)

- M2.6x7 (79871020)
- M2.6x15 (79871050)
- M2.6x18 (79871055)



21RG, 21RG(P) ENGINE EXPLODED VIEW

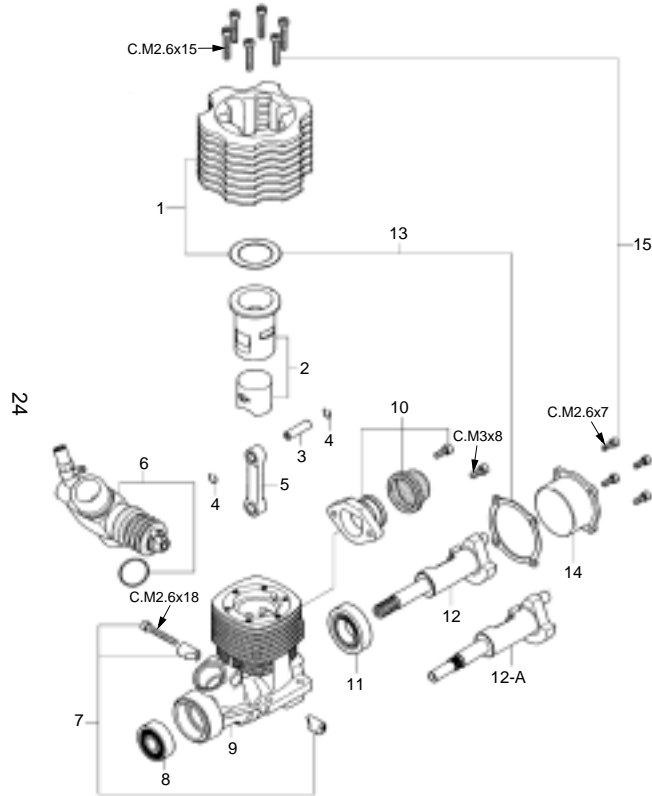

*Type of screw
 C...Cap Screw M...Oval Fillister-Head Screw
 F...Flat Head Screw N...Round Head Screw S...Set Screw

21RG, 21RG(P) ENGINE PARTS LIST

No.	Code No.	Description
1	23604010	Heatsink Head
2	23603000	Cylinder & Piston Assembly
3	23906000	Piston Pin
4	23817000	Piston Pin Retainer (2pcs.)
5	23605000	Connecting Rod
6	23618001	Carburetor Complete (Type 20E)
7	23981700	Carburetor Retainer (with screw)
8	41614000	Crankshaft Ball Bearing (Front)
9	23601000	Crankcase
10	23626100	Exhaust Adaptor (No.5)
11	22830000	Crankshaft Ball Bearing (Rear)
12	23602000	Crankshaft (For 21RG)
12-A	23602010	Crankshaft (For 21RG(P))
13	23614000	Gasket Set
14	23607000	Cover Plate
15	22447005	Screw Set
	72411000	Super Air Cleaner 201 (W/two filter elements)
	72411020	201 Filter Elements (4pcs.)
	72411050	Element Plate Set Comprising:
	72411010	Center Screen
	72411040	Intake Elbow
	72411030	Center Tube
	71608001	Glow Plug No.8

The specifications are subject to alteration for improvement without notice.

21RG-X, 21RG(P)-X ENGINE EXPLODED VIEW

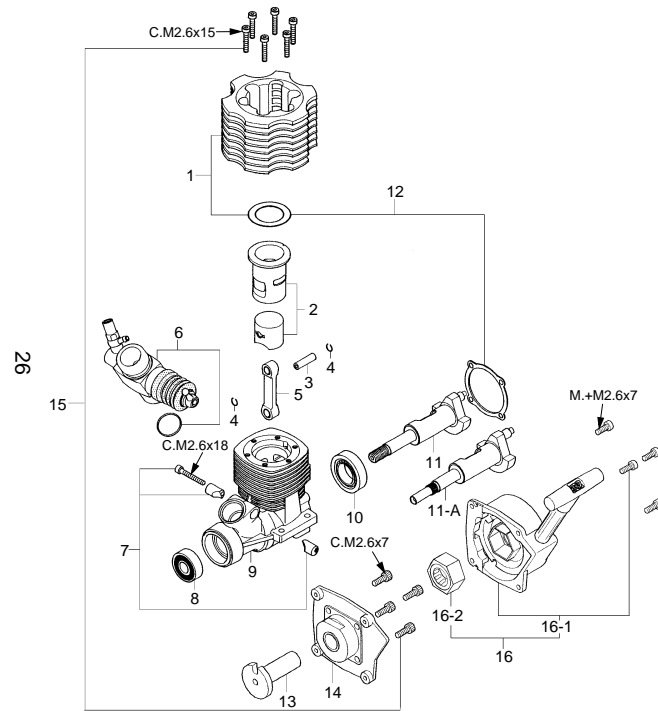

* Type of screw
 C...Cap Screw M...Oval Fillister-Head Screw
 F...Flat Head Screw N...Round Head Screw S...Set Screw

21RG-X, 21RG(P)-X ENGINE PARTS LIST

No.	Code No.	Description
1	23604010	Heatsink Head
2	23603000	Cylinder & Piston Assembly
3	23906000	Piston Pin
4	23817000	Piston Pin Retainer (2pcs.)
5	23605000	Connecting Rod
6	23618001	Carburetor Complete (Type 20E)
7	23981700	Carburetor Retainer (with screw)
8	41614000	Crankshaft Ball Bearing (Front)
9	23601000	Crankcase
10	22830000	Crankshaft Ball Bearing (Rear)
11	23602030	Crankshaft (For 21RG-X)
11-A	23602020	Crankshaft (For 21RG(P)-X)
12	23614000	Gasket Set
13	23602050	Starting Shaft
14	23601800	Rear Adaptor
15	22447005	Screw Set
16	73003000	No.5 Recoil Starter Assembly
16-1	73003100	No.5 Recoil Starter Body
16-2	73003200	No.5 Oneway Clutch
	72404110	Mount Spacer
	72411000	Super Air Cleaner 201 (W/two filter elements)
	72411020	201 Filter Elements (4pcs.)
	72411050	Element Plate Set Comprising:
	72411010	Center Screen
	72411040	Intake Elbow
	72411030	Center Tube
	71608001	Glow Plug No.8

The specifications are subject to alteration for improvement without notice.

CARBURETOR EXPLODED VIEW

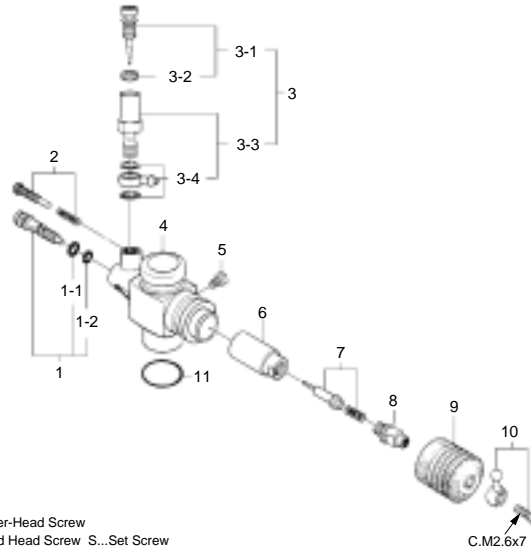

* Type of screw

C...Cap Screw M...Oval Fillister-Head Screw
F...Flat Head Screw N...Round Head Screw S...Set Screw

28

CARBURETOR PARTS LIST

No.	Code No.	Description
1	23818180	Mixture Control Valve Assembly
1-1	46066319	"O" Ring(L) (2pcs.)
1-2	22781800	"O" Ring(S) (2pcs.)
2	23818500	Throttle Stop Screw
3	23618190	Needle Valve Assembly
3-1	23618197	Needle Assembly
3-2	46066319	"O" Ring
3-3	23618194	Needle Holder Assembly
3-4	23818176	Universal Nipple No.9
4	23618102	Carburetor Body
5	45581820	Slide Valve Guide Screw
6	23818251	Slide Valve
7	23818310	Metering Needle Assembly
8	23818220	Slide Valve Extension
9	22884220	Dust Cover
10	23818400	Ball Link No.1
11	29015019	Carburetor Rubber Gasket

The specifications are subject to alteration for improvement without notice.

29

THREE VIEW DRAWING

Dimensions(mm)

SPECIFICATIONS	
■ Displacement	3.46 cc / 0.211 cu. in
■ Bore	16.6 mm / 0.654 in
■ Stroke	16.0 mm / 0.630 in
■ Practical R.P.M.	3,000-35,000 r.p.m.
■ Power output	1.9 ps / 30,000 r.p.m.
■ Weight	325g / 11.47 oz.(RG,RG(P)) 397.5g / 14.03 oz.(RG-X,RG(P)-X)

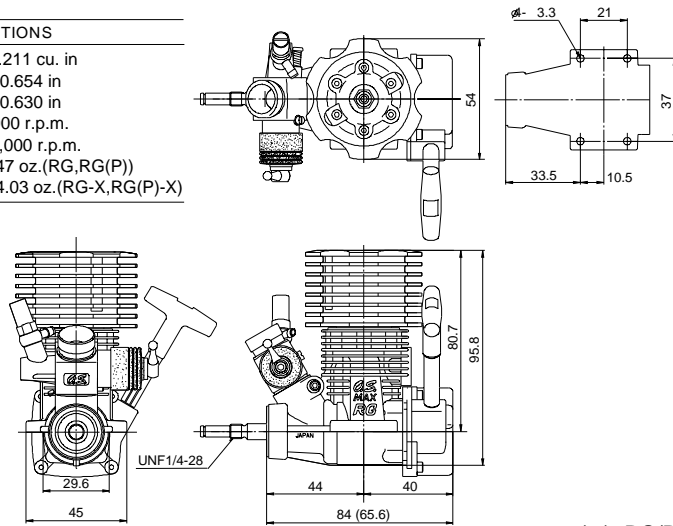

() -RG/RG(P)

30



O.S. ENGINES MFG.CO.,LTD.

6-15 3-Chome Imagawa Higashisumiyoshi-ku
Osaka 546-0003, Japan TEL. (06) 6702-0225
FAX. (06) 6704-2722
URL : <http://www.os-engines.co.jp>