

O.S. ENGINE MAX-18TM w/11K Carburetor & T-Maxx Manifold

OWNER'S INSTRUCTION MANUAL

It is of vital importance, before attempting to operate your engine, to read the general **•SAFETY INSTRUCTIONS AND WARNINGS•** section on pages 2-5 of this booklet and to strictly adhere to the advice contained therein.

- Also, please study the entire contents of this instruction manual, so as to familiarize yourself with the controls and other features of the engine.
- Keep these instructions in a safe place so that you may readily refer to them whenever necessary.
- It is suggested that any instructions supplied with the vehicle, radio control equipment, etc., are accessible for checking at the same time.

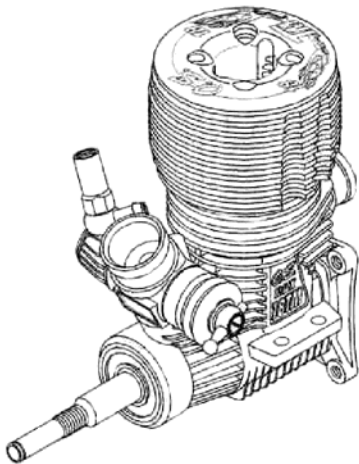

CONTENTS

SAFETY INSTRUCTIONS AND WARNINGS ABOUT YOUR O.S. ENGINE ----	2-5
ENGINE CONSTRUCTION -----	6
NOTES WHEN APPLYING AN ELECTRIC STARTER -----	7
ABOUT THE ENGINE -----	8
BEFORE STARTING-----	8-10
BASIC ENGINE PARTS -----	10
CARBURETOR CONTROLS-----	11
FACTS ABOUT GLOWPLUG-----	12
INSTALLATION OF THE CARBURETOR ----	13
INSTALLATION-----	13-16
STARTING THE ENGINE & RUNNING-IN-----	17-19

FINAL ADJUSTMENT-----	20-22
CARBURETOR CLEANLINESS-----	22
CARE AND MAINTENANCE-----	23-24
CHECKING THE ENGINE-----	25
TROUBLE SHOOTING-----	26-29
ENGINE EXPLODED VIEW & PARTS LIST---	30-31
CARBURETOR EXPLODED VIEW & PARTS LIST-----	32-33
O.S. GENUINE PARTS & ACCESSORIES-----	34
THREE VIEW DRAWING -----	35
GUARANTEED TO KEEP YOUR R/C CAR RUNNING WELL-----	36-39
LIMITED WARRANTY-----	41

SAFETY INSTRUCTIONS AND WARNINGS ABOUT YOUR O.S. ENGINE

Remember that your engine is not a "toy", but a highly efficient internal-combustion machine whose power is capable of harming you, or others, if it is misused.

As owner, you, alone, are responsible for the safe operation of your engine, so act with discretion and care at all times.

If at some future date, your O.S. engine is acquired by another person, we would respectfully request that these instructions are also passed on to its new owner.

- The advice which follows applies basically to ALL MODEL ENGINES and is grouped under two headings according to the degree of damage or danger which might arise through misuse or neglect.



WARNINGS

These cover events which might involve serious (in extreme circumstances, even fatal) injury.



NOTES

These cover the many other possibilities, generally less obvious sources of danger, but which, under certain circumstances, may also cause damage or injury.



WARNINGS

Model engine fuel is poisonous. Do not allow it to come into contact with the eyes or mouth. Always store it in a clearly marked container and out of the reach of children.



- Never operate your engine in an enclosed space. Model engines, like automobile engines, exhaust deadly carbon-monoxide. Run your engine only in an open area.

Model engine fuel is also highly flammable. Keep it away from an open flame, excessive heat, sources of sparks, or anything else which might ignite it. Do not smoke or allow anyone else to smoke, near to it.



- Model engines generate considerable heat. Do not touch any part of your engine until it has cooled. Contact with the muffler (silencer), cylinder head or exhaust header pipe, in particular, may result in a serious burn.





NOTES

- This engine is intended for model cars. Do not attempt to use it for any other purpose.
- Mount the engine in your model securely, following the manufacturers' recommendations, using appropriate screws and locknuts.
- Install an effective silencer (muffler). Frequent close exposure to a noisy exhaust (especially in the case of the more powerful highspeed engines) may eventually impair your hearing and such noise is also likely to cause annoyance to others over a wide area.
- The wearing of safety glasses is also strongly recommended.
- Take care that the glowplug clip or battery leads do not come into contact with rotating parts. Also check that the linkage to the throttle arm is secure.
- For their safety, keep all onlookers (especially small children) well back (at least 20 feet or 6 meters) when preparing your model for running.



NOTES

- To stop the engine, fully retard the throttle stick and trim lever on the trans-mitter, or, in an emergency, cut off the fuel supply by pinching the fuel delivery line from the tank.
- Warning! Immediately after a glowplug-ignition engine has been run and is still warm, conditions sometimes exist whereby it is just possible for the engine to abruptly restart if it is rotated over compression **WITHOUT** the glowplug battery being reconnected.

ENGINE CONSTRUCTION

With this engine, the piston will feel tight at the top of its stroke (TDC) when the engine is cold. This is normal. The cylinder bore has a slight taper. The piston and cylinder are designed to achieve a perfect running clearance when they reach operating temperature.

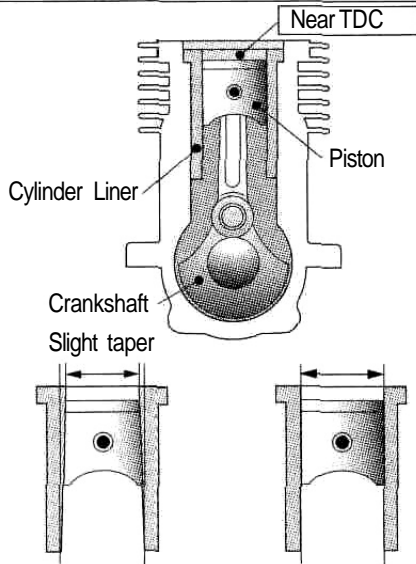

When the engine is cold. When the engine is hot.

NOTES WHEN APPLYING AN ELECTRIC STARTER

Do not over-prime. This could cause a hydraulic lock and damage the engine on application of the electric starter.

If over-primed, remove glowplug, close needle-valve and apply starter to pump out surplus fuel. Cover the head with a rag to prevent pumped out fuel coming into your eyes.

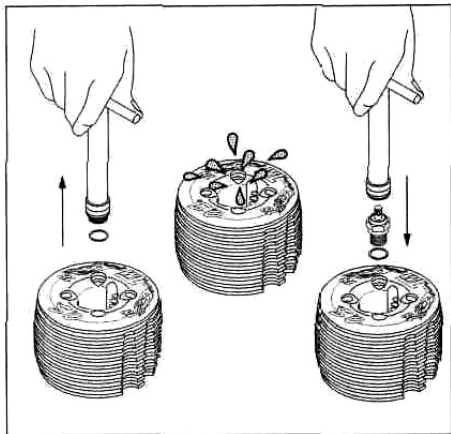

ABOUT THE ENGINE

This engine is designed especially to power the T-Maxx. Purposely designed LC3 glow plug is supplied with the engine for improved power, fuel economy and durability. The new UK carburetor offers easy handling as well as high performance.

"T-Maxx" is a trademark of Traxxas Corp.

Standard accessories

- Glow Plug LC3
- Exhaust Seal Ring 1 piece
- Exhaust Manifold for T-Maxx Assembly

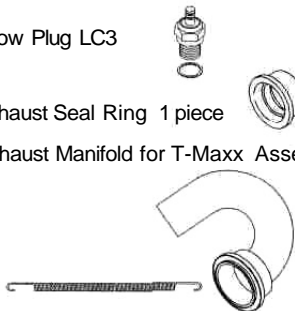

BEFORE STARTING

Tools, accessories, etc. The following items are necessary for operating the engine.

■ Items necessary for starting

FUEL

Generally, it is suggested that the user selects a fuel that is commercially available for model two-stroke engines and contains 10-30% nitromethane. As a starting point, we recommend a fuel containing 20% nitromethane, changing to a fuel containing more nitro if necessary. When the brand of fuel is changed, or the nitro content increased, it is advisable to repeat the running-in procedure referred to in the RUNNING-IN paragraphs. Please note that with high-nitro fuels, although power may be increased for competition purposes, glowplug elements do not last as long and engine life will be shortened.





Model engine fuel is poisonous. Do not allow it to come into contact with the eyes or mouth. Always store it in a clearly marked container and out of the reach of children.



Model engine fuel is also highly flammable. Keep it away from open flame, excessive heat, sources of sparks, or anything else which might ignite it. Do not smoke or allow anyone else to smoke, near to it.

FUEL FILTER

To installed in the fuel line between fuel tank and carburetor to prevent dust coming into the carburetor.

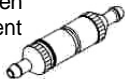

GLOWPLUG IGNITER

Commercially available handy glowplug heater in which the glowplug battery and battery leads are integrated.

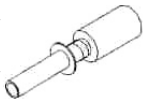

FUEL PUMP

For filling the fuel tank, a simple, polyethylene "squeeze" bottle, with a suitable spout, is required.



SILICONE FUEL LINE

Heatproof silicone tubing of approx. 5mm o.d. and 2mm i.d. is required for the connection between the fuel tank and engine.



■ TOOLS

HEX WRENCH

Necessary for engine installation.

1.5mm, 2mm, 2.5mm, 3mm



SCREWDRIVER

Necessary for carburetor adjustments.

No.1, No.2, etc

LONG SOCKET WRENCH WITH PLUG GRIP

Recommended for easy removal and replacement of the angled and recessed glowplug, the O.S. Long Socket Wrench incorporates a special grip.

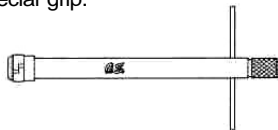

BASIC ENGINE PARTS

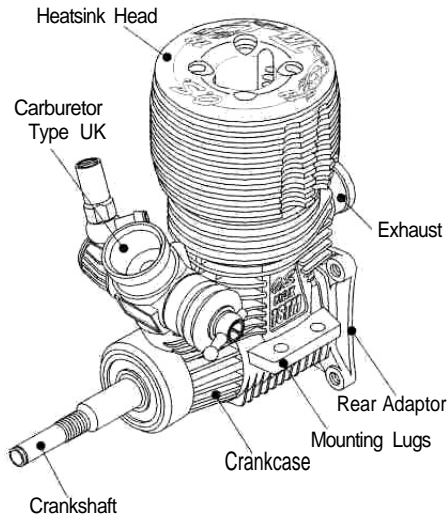

CARBURETOR CONTROLS

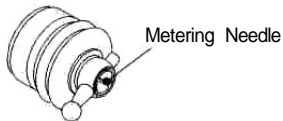
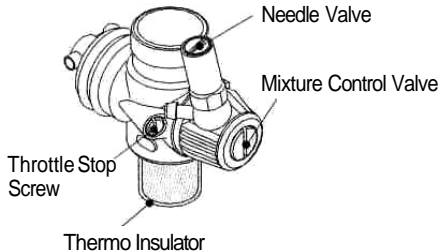

Four adjustable controls are provided on this carburetor.

- **The Needle-Valve:**

For adjusting the mixture strength when the throttle is fully open.

- **The Mixture Control Valve:**

For changing the mixture strength at mid speed and acceleration. (Do not rotate the screw more than one turn.)

- **The Metering Needle:**

For adjusting the mixture strength at part-throttle and idling speeds, to obtain steady idling and smooth acceleration to mid speeds.

- **The Throttle Stop Screw:**

For setting the minimum idle speed:

NOTE: Readjustment may be necessary, occasionally to allow for changes in fuel formula gear ratio or clutch engagement point.

FACTS ABOUT GLOWPLUGS

Since the compatibility of glowplug and fuel may have a marked effect on performance and reliability, it may be worthwhile to choose the R/C type plug found most suitable after tests. Recommended O.S. plugs are LC3. Carefully install plug finger-tight, before final tightening with the correct size plug wrench.

The role of the glowplug

With a glowplug engine, ignition is initiated by the application of a 1.5-volt power source. When the battery is disconnected, the heat retained within the combustion chamber remains sufficient to keep the plug filament glowing, thereby continuing to keep the engine running. Ignition timing is 'automatic' : under reduced load, allowing higher rpm, the plug becomes hotter and, appropriately, fires the fuel/air charge earlier; conversely, at reduced rpm, the plug become cooler and ignition is retarded.

Glowplug life

Particularly in the case of very high performance engines, glowplugs must be regarded as expendable items.

However, plug life can be extended and engine performance maintained by careful use, i.e.:

- Install a plug suitable for the engine.
- Use fuel containing a moderate percentage of nitromethane.
- Do not run the engine too lean and do not leave the battery connected while adjusting the needle.

When to replace the glowplug

Apart from when actually burned out, a plug may need to be replaced because it no longer delivers its best performance, such as when:

- Filament surface has roughened and turned white.
- Filament coil has become distorted.
- Foreign matter has adhered to filament or plug body has corroded.
- Engine tends to cut out when idling.
- Starting qualities deteriorate.

INSTALLATION

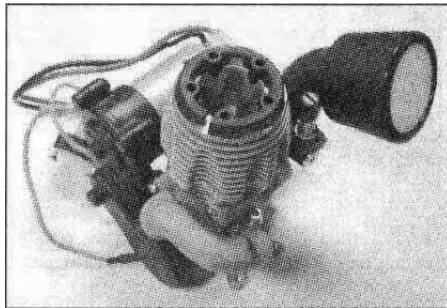
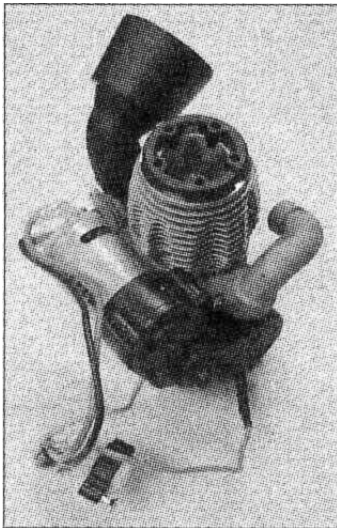

First, remove the engine, installed as standard, with the engine mount.

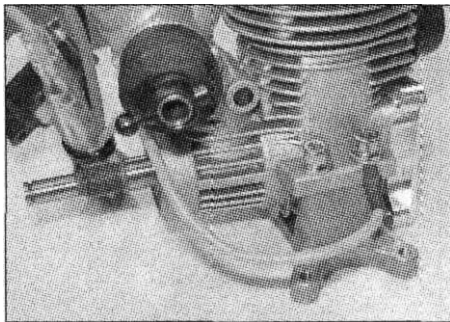

Install the engine on the engine mount with earthwire.

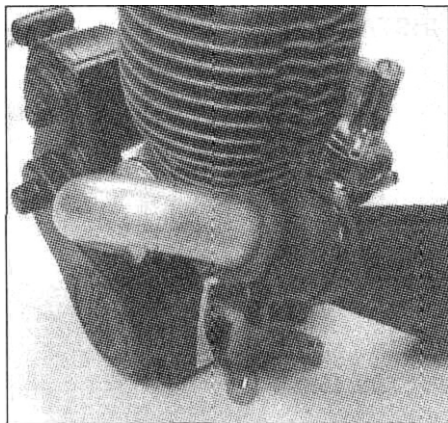

Install the manifold supplied with the engine.

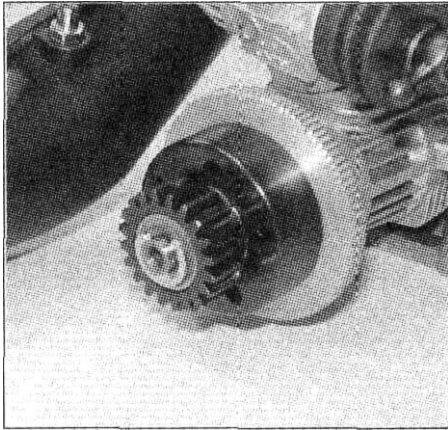

Install the flywheel and clutch.

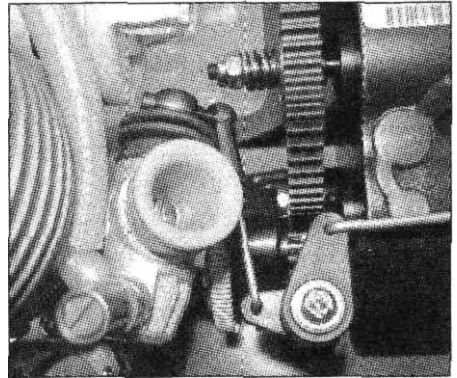

Adjust the plastic ball end so that the throttle linkage may be made correctly.

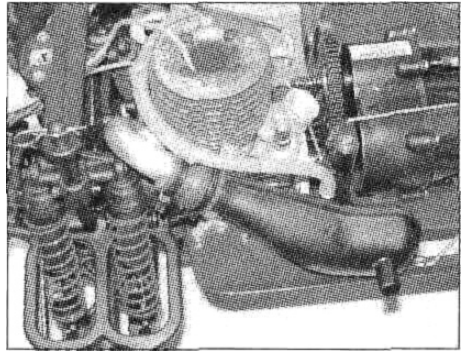
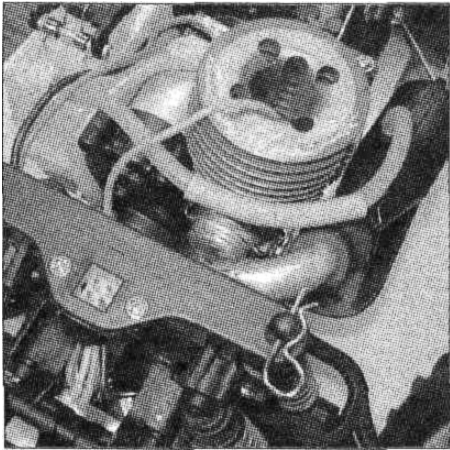

Finally, insert the wire for glow plug heating in the glow plug.

STARTING THE ENGINE & RUNNING-IN ('Breaking-in')

For long life and high performance, every engine needs to be 'run-in' or 'broken-in'. With care, running-in of the MAX-18TM can be carried out with the engine installed in the vehicle. Be sure to install the air-cleaner on the carburetor and use a muffler-pressurized fuel system.

- The somewhat violent changes of vehicle attitude that occur in off-road running, combined with the fact that, in buggy type cars, the fuel tank is often located some distance from the carburetor, means that fuel 'head' at the carburetor can vary and upset running. Therefore, it is recommended that a muffler pressurized fuel feed system be used.
- Never run your vehicle without installing the air cleaner. Dust and dirt that may otherwise be drawn into the engine will rapidly shorten its life.

- ◆ Fill the tank completely with fuel.
- ◆ Temporarily remove the glowplug to check that it glows bright red when energized.

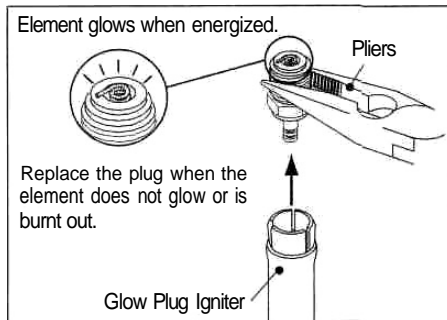

- The carburetor of this engine is set at starting setting when the engine leaves the factory.
- Switch on the transmitter, and check that all the linkage moves correctly.

Remember!

It is vitally important to set the throttle at the correct position before attempting to start the engine. If the engine is allowed to run with the throttle too far open under "no load" conditions, it will rapidly overheat and may be seriously damaged.



- When the engine starts, first allow it to operate in short runs on its very rich starting settings, with the glowplug battery still connected and with its driving wheels clear of the ground. The rich mixture will, under these conditions, provide adequate lubrication and cooling, indicated by profuse smoke from the exhaust.

- Next, disconnect the glowplug battery and try running the car on the track. If the engine stalls, open the throttle fractionally, but try to keep the engine running as rich as possible: if it stops because of being excessively over-rich, close the Needle-Valve 30° and try again.
- Run the car on the track until one tank of fuel has been consumed, then close the Needle-Valve 30°. Repeat this procedure again until five tanks of fuel have been consumed, during which time the throttle may be opened for brief bursts of increased power. If the engine stops at medium speeds, close the Mixture Screw 45-90°.

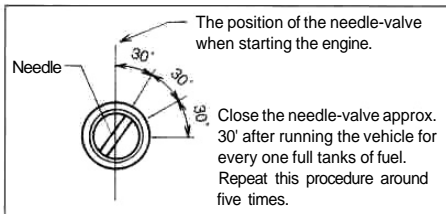

Note:

If the engine should need to be disassembled (e.g. for cleaning or minor parts replacement), it is advisable to return the needle-valve to the original rich, starting setting and check whether further running-in time is required before the car is raced again. In the event of any major working parts (e.g. piston/cylinder liner assembly) being replaced or the fuel being changed, especially to high nitro fuel, the complete running-in should be repeated.

- ◆ To stop the engine, close the throttle to idling speed, then shut it off completely with the trim lever on the transmitter.

To cut off the fuel supply, pinch the fuel delivery tube to the carburetor.

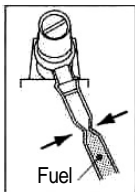

Warning!

Do not touch rotating parts, engine and silencer when stopping the engine as they become very hot, and contact with them may result in a serious burn,

FINAL ADJUSTMENT

Final adjustment should be carried out only after the running-in has been completed.

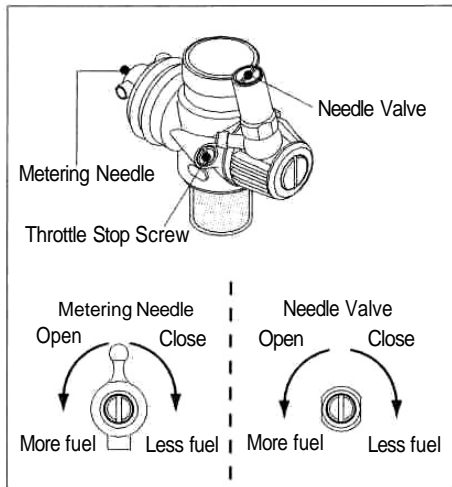

- ◆ Run the vehicle (with throttle fully open) over the longest available straight course, in order to observe the model's speed. Next return the car to the starting point, close the Needle-Valve 30° and repeat the run, taking note of the improvement in performance.
- ◆ Continue with further runs, gradually reducing the Needle-Valve setting and aiming to achieve the highest straight-line speed. Remember, however, that, if the Needle-Valve is shut down too far, the engine will overheat and, accompanied by visibly diminished exhaust smoke, the model will lose speed. At this point, throttle down immediately, stop the vehicle and reopen the Needle-Valve 45-90°.

- ◆ With the engine running, close the throttle and allow it to idle for about five seconds, then reopen the throttle fully. If, at this point, the engine puffs out an excessive amount of smoke and the vehicle does not accelerate smoothly and rapidly, it is probable that the idle mixture is too rich. In this case, turn the Metering Needle clockwise 45-90°. If, on the other hand, the engine tends to speed up momentarily and then cut out abruptly when the throttle is opened, the idle mixture is too lean. Correct this by turning the Metering Needle counter-clockwise 45-90°.

NOTE:

Metering Needle adjustment should be made in steps of not more than 45-90°, carefully checking the effect, on throttle response, of each small adjustment.

- ◆ **Carry out** adjustments patiently, under actual running conditions, until the engine responds quickly and positively to the throttle control.

Warning!

Mixture adjustments (whether via the Metering Needle, or the Needle-Valve) cannot be made accurately under 'no-load' conditions, which, in any case, are not advised, since such operation carries the risk of seriously damaging the engine through over-revving and overheating.

- ◆ With the optimum mixture control position, light smoke is visible during high speed running, and the engine rpm increases smoothly during acceleration. Remember that, if the engine is operated with the fuel/air mixture slightly too lean, it will overheat and run unevenly. As with all engines, it is advisable to set both the needle-valve and metering needle slightly on the rich side of the best rpm setting, as a safety measure.
- ◆ If the engine runs too fast with the throttle closed, the throttle stop screw should be turned counter-clockwise to allow the throttle opening to be reduced.

- ◆ Finally, beyond the nominal break-in period, a slight readjustment toward a leaner needle setting may be required to maintain maximum performance.

CARBURETOR CLEANLINESS

The correct functioning of the carburetor depends on its small fuel orifices remaining **clear**.

■ REALIGNMENT OF METERING NEEDLE AND MIXTURE CONTROL VALVE

In the course of making carburetor adjustments, it is just possible that the Metering Needle and the Mixture Control Valve may be inadvertently screwed in or out too far and thereby moved beyond its effective adjustment range.

The basic positions can be found by rotating the Metering Needle until its slotted head is flush with the ball link body,

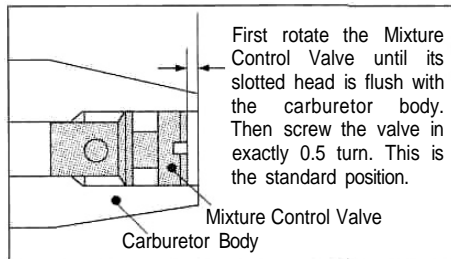
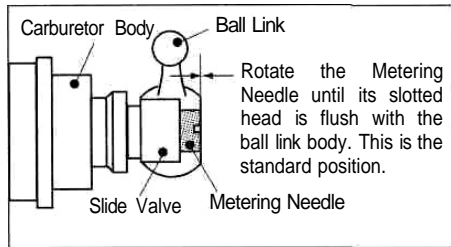

CARE AND MAINTENANCE

1. The minute particles of foreign matter, that are present in any fuel may, by accumulating and partially obstructing fuel flow, cause engine performance to become erratic and unreliable.
O.S. 'Super-Filters' (large and small) are available, as optional extras, to deal with this problem.
One of these filters installed to the pickup tube inside your refueling container, will prevent the entry of foreign material into the fuel tank. It is also recommended that a good in-line filter be installed between the tank and carburetor.
2. Do not forget to clean the filters regularly to remove dirt and lint that accumulate on the filter screens. Also, clean the carburetor itself occasionally.

3. At the end of each operating session, drain out any fuel that may remain in the fuel tank. Afterwards, energize the glow-plug and try to restart the engine, to burn off any fuel that may remain inside the engine. Repeat this procedure until the engine fails to fire. Do this while the engine is still warm.
4. Then, inject some after-run oil into the engine, and rotate the engine with an electric starter for 4 to 5 seconds to distribute the oil to all the working parts.

Note:

Do not inject after-run oil into the carburetor as this may cause the 0-rings inside the carburetor to deteriorate. These procedures will reduce the risks of starting difficulties or corrosion after a period of storage.

5. Finally, when cleaning the exterior of the engine, use methanol or kerosene. Do not use gasoline or any solvent that might damage the silicone fuel tubing.

Caution:

The rear crankshaft bearing of this engine uses a special plastic retainer. If the front housing needs to be heated to remove or replace the bearing, do not allow the bearing to exceed 120°C (248T), otherwise it may be damaged and rendered unserviceable.

- **Installing Dust Caps**

When storing the engine, install the cap on the exhaust port, carburetor, etc. to prevent dust from entering the engine.

Dirt and dust may lodge in  marked places.

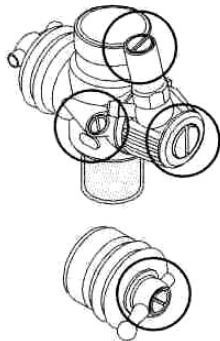

CHECKING THE ENGINE

Engine will not develop normal performance after long time running due to wearing of parts. It is suggested to replace necessary parts when the following symptoms are detected.

- ◆ Engine sound changes and easily overheats.
- ◆ Power has dropped extremely.
- ◆ Idling is unstable and/or engine tends to stop at idling.

In most cases, ball bearings, cylinder & piston assembly, connecting rod and/or crankcase have become worn out or abnormal. Check the parts carefully and replace them if necessary.

TROUBLE SHOOTING

Symptom	
Engine fails to fire.	
Cause	Corrective action
Fuel tank is empty. Fuel not reaching the engine.	Fill the tank with fuel and repeat Priming procedure.
Glowplug element is burnt out. Glowplug battery discharged	Replace glowplug. Recharge or replace the battery.
Clogged fuel filter Air cleaner and silencer inside is dirty.	Clean or replace fuel filter. Replace cleaner element and clean inside silencer.
Over priming	Remove glowplug and pump excess fuel.
Fuel tubing is disconnected. Fuel tubing is kinked, split or has a hole.	Connect fuel tubing securely. Check the tubing carefully and replace if necessary.
Incorrect carburetor settings	Return the metering needle and mixture control valve to basic position.
Incorrect servo linkage	Re-linkage after setting servo at neutral.

Symptom	
Engine fires intermittently but does not run.	
Cause	Corrective action
Insufficient fuel in the tank.	Fill the tank with fuel.
Deteriorated glowplug	Replace glowplug.
Clogged fuel filter Air cleaner and silencer inside is dirty.	Clean or replace fuel filter. Replace cleaner element and clean inside silencer.
Engine overheated	Wait until engine is cooled.
Incorrect clutch release	Adjust the tension of clutch spring.
Too immediately disconnecting plug battery.	Do not disconnect plug battery and wait until r.p.m. become stable,
Fuel in the tank extremely bubbled	Fit O rings to the tank screws to prevent bubbles.

Symptom	
Unstable Idle	
Cause	Corrective action
Unsuitable glowplug	Use suggested glowplug in the instructions.
Unsuitable fuel	Do not use extremely high nitro or low oil fuel.
Extremely light flywheel	Add suitable load.
Silencer is disconnected or has play	Install silencer securely.
Symptom	
Not reaching expected peak r.p.m.	
Cause	Corrective action
Insufficient warming up or running-in.	Set the needle only after warming up. Complete running-in.
Silencer or manifold is not securely connected or disconnected.	Replace seal ring. Check the connections and secure them.
Fuel tubing from tank to is split or broken.	Replace the tubing.

Symptom	
Poor response	
Cause	Corrective action
Deteriorated glowplug	Replace glowplug.
Incorrect carburetor settings	Readjust low r.p.m. range with metering needle and mixture control valve.
Incorrect setting of transmitter Exponential function.	Check the transmitter setting.
Symptom	
Poor r.p.m. drop	
Cause	Corrective action
Too much throttle opening at idle.	Close metering needle to adequate position to lower idle r.p.m.
Incorrect carburetor fitting	Fit carburetor securely.

ENGINE EXPLODED VIEW

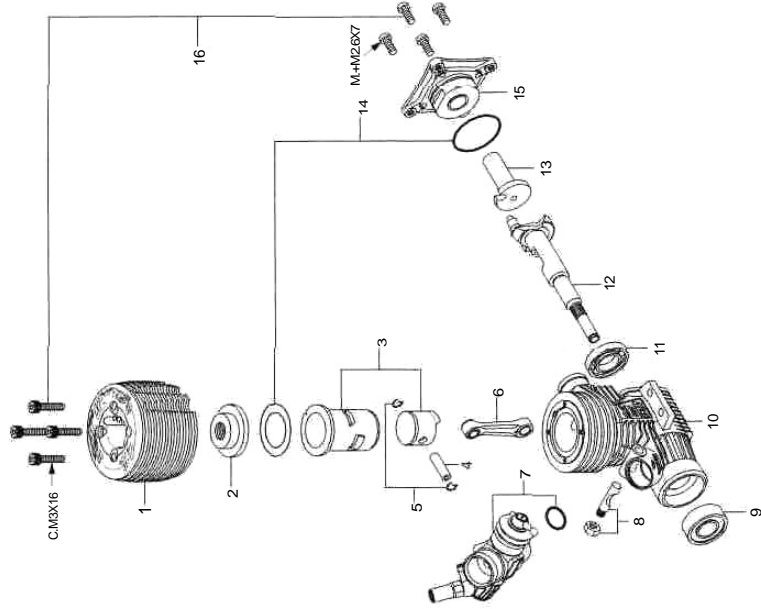

30

*Type of screw C—"Cap Screw M—Oval Fillister-Head Screw
F—Flat Head Screw N—Round Head Screw S—Set Screw

ENGINE PARTS LIST

No.	Code No.	Description
1	21914000	Outer Head
2	21914100	Inner Head
3	21913000	Cylinder & Piston Assembly
4	21816000	Piston Pin
5	21817000	Piston Pin Retainer (2pcs.)
6	21915000	Connecting Rod
7	21982000	Carburetor Complete (Type 11 K)
8	25381701	Carburetor Retainer
9	23731000	Crankshaft Ball Bearing (Front)
10	21911000	Crankcase
11	21931000	Crankshaft Ball Bearing (Rear)
12	21912000	Crankshaft
13	21922000	Starting Shaft
14	21824000	Gasket Set
15	21911800	Rear Adaptor
16	21923000	Screw Set
	71653000	Glow Plug LC3
	21427200	Exhaust Seal Ring (2pcs.)
	72103610	Exhaust Manifold for T-Maxx
	72106172	Manifold Spring (2pcs.)

The specifications are subject to alteration for improvement without notice.

CARBURETOR EXPLODED VIEW

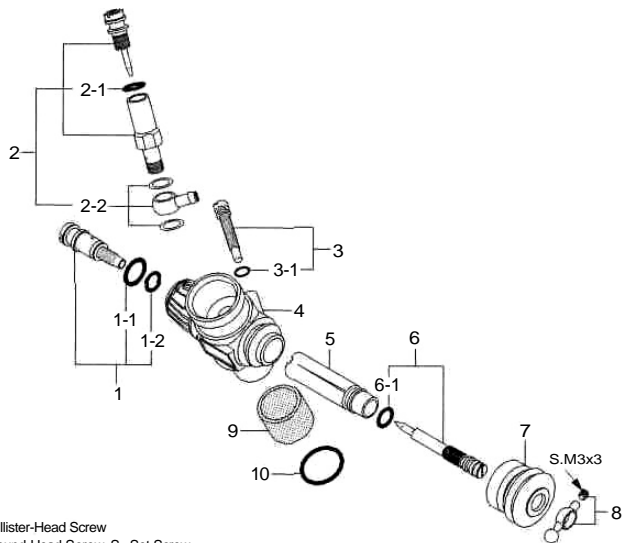

* Type of screw

C...Cap Screw M...oval Fillister-Head Screw

F...Flat Head Screw N...Round Head Screw S...Set Screw

CARBURETOR PARTS LIST

No.	Code No.	Description
1	21982600	Mixture Control Valve Assembly
1-1	27881820	"0" Ring(L) (2pcs.)
1-2	22781800	"0" Ring(S) (2pcs.)
2	21285901	Needle Valve Assembly
2-1	27881820	"0" Ring (2pcs.)
2-2	21881950	No.14 Universal Nipple Assembly
3	21982620	Throttle Stop Screw
3-1	22781800	"0" Ring(S) (2pcs.)
4	21982100	Carburetor Body (w/Thermo Insulator)
5	21982200	Slide Valve
6	21982540	Metering Needle Assembly
6-1	22781800	"0" Ring(S) (2pcs.)
7	21982520	Dust Cover
8	23818430	Ball Link No.5
9	21982900	Thermo Insulator
10	22615000	Carburetor Rubber Gasket

The specifications are subject to alteration for improvement without notice.

■ O.S. Glow Plug



LC3
(71653000)

■ Exhaust Seal Ring

(2pcs.)

(21427200)



■ Manifold Spring (2pcs.)

(72106172)



∅ 3 (73300305)
For Carburetor Nipple

∅ 7 (73300712)
For Silencer

∅ 12 (73301212)
For Carburetor



■ Long Socket Wrench
With Plug Grip

(71521000)

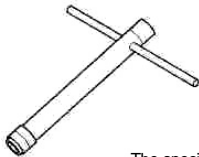

The specifications are subject to alteration for improvement without notice.

THREE VIEW DRAWING

SPECIFICATIONS

■ Displacement	3.0cc (0.183cu.in.)
■ Bore	16.0mm (0.629in.)
■ Stroke	15.0mm (0.590in.)
■ Practical R.P.M.	3,000-34,000 r.p.m.
■ Power output	1.6ps/29,000 r.p.m.
■ Weight	233g (8.22oz.)

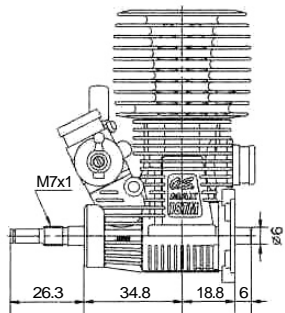
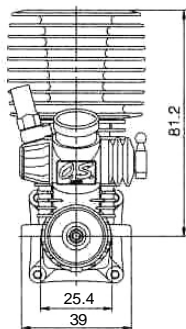
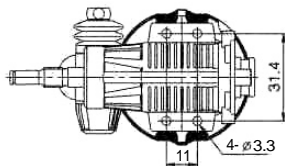

Dimensions (mm)

10 Ways

GUARANTEED TO KEEP YOUR R/C CAR RUNNING WELL

1 KEEP IT CLEAN

Dirt is the most common way to ruin your engine. If it gets inside, the dirt will act just like sandpaper and ruin the close fit that the parts need for your engine to operate correctly.

- Use an air filter to keep as much dirt outside as possible. A two or three stage filter with an oiled foam element is the best way to go.
- Dirt on the outside of the engine acts just like a blanket of insulation and prevents proper cooling. Keep your engine clean.
- Use a fuel filter. Dirt getting into the fuel will clog the fuel passages in the carburetor and also get those abrasive particles inside. Keep your engine clean.
- Dirt will damage your engine very quickly and repairs for dirt are not covered by the engine manufacturer's warranty.

2 KEEP IT RICH

The high-speed needle valve is used to adjust the mixture of fuel and air needed to get the optimum performance from your engine. If it's adjusted too lean, your engine will get less fuel than it should.

- You must remember that the engine gets its lubrication from the oil that's in the fuel. If you run it too lean, the engine will not get enough oil to keep the internal parts lubricated, even though it sounds better.
- Parts will start to run hot and then seize. The result is a typical problem as a broken connecting rod that seized to the crankshaft, and then broke as the crankshaft tried to continue to turn.
- Keep the engine running on the rich side of the highest RPM setting to ensure proper lubrication.

3 KEEP IT ON THE GROUND

You should run your engine at high speeds only when you are driving the car.

- Do not put the car on the box or stand with the wheels off the ground and then run the engine. You'll quickly overspeed your engine and ruin it. Generally, the connecting rod will break from the over-revving.
- Do not remove the engine from the car and try to run it with just the flywheel. That does the same as described above. The engine must be run with the load of the car when driving.

4 KEEP IT COOL

If you run your engine good and hot, you'll have a nice chunk of useless aluminum in a short time.

- **Running the engine hot causes the oil in the fuel to break down and quit working. The repairs won't be cheap.**

Your engine is equipped with a special heat-sink cylinder head to make sure it gets enough cooling..

- **Keep the head clean so that the dirt doesn't act like an insulating blanket.**
- **Make sure that any airflow passes through the fins of the cylinder and head.**
- **Make as many cutouts in the car's body as necessary, and don't skimp on the size.**

5 KEEP IT LUBED

Make sure you're using a fuel from a reputable, name-brand manufacturer.

- **Your fuel should have at least the amount of oil recommended by the engine manufacturer. If you can't find a particular recommendation on oil content, then use a fuel with 20%-22% oil content.**
- **If you're trying to run a fuel with more than 20% Nitromethane, you should add some oil to your fuel, such as KlotzTechniplate™ or Baker "AA" Castor Oil™.**

6 KEEP IT PROPERLY LUBED DURING STORAGE

If you let your engine sit with nothing done to it after you last ran it, the internal parts will start to corrode... especially the steel crankshaft and ball bearings. They'll rust. If the fuel has castor oil in it, it will begin to dry out and become gummy.

- **Rust inside an engine will erode tight clearances and score polished surfaces.**
- **Gummy fuel residue blocks oil holes in connecting rods and crankshafts.**

10 Ways

GUARANTEED TO KEEP YOUR R/C CAR RUNNING WELL

(Continued)

6 (CONTINUED)

Here's how to prevent rust;

- At the end of the day's running, pull the fuel line from the engine.
- Drain the tank, and then start the engine.
- Let it run until it's absolutely dry of fuel.
- Add several drops of an after-run oil. There are several after-run oils on the hobby market. You can also make your own from a 50-50 mixture of "Marvel Mystery Oil"TM and automatic transmission fluid.
- After adding the after-run oil, turn the engine over several times to make sure it's worked into all of the engine's internals. Add more if you are not sure that you put in enough.

7 KEEP GOOD POWER

Nitro, or Nitromethane, is the main power ingredient in model fuels. Raising the nitro content will make the fuel "hotter"—that is, allow the engine to develop more power. More is better, right? Not really.

- Unless your engine is designed and ported for high-nitro fuels, you won't see much gain in performance above 20%-25%.
- While some people are running nitro levels as high as 50%, they have modified their engines to handle it. They've also carefully blended their fuel to make sure they have enough oil.
- The best performance enhancer is a good driver. A driver who can keep the car on the track will usually beat a less experienced driver with a hotter set up.

8 KEEP IT SMOOTH

When you tighten the pilot shaft onto your flywheel, it can be hard to keep the engine from turning over. It may be tempting to stick something into the exhaust port to keep the piston from moving, but do not do this! You'll also put a nice "ding" in the piston and in the cylinder liner. You've just ruined your nice, new engine. A new ABC piston/cylinder assembly (the most commonly-used kind in R/C car engines) will put a nice hole in your pocketbook.

8 (CONTINUED)

This kind of damage is not covered under the warranty.

- If the flywheel can't be tightened onto the engine without it trying to turn over, grip the drive washer in a pair of large adjustable pliers, like Channel Locks™, with the drive washer protected under several layers cloth. You could also try a strap wrench.
- If you feel more adventurous, you can remove the rear cover of the engine and insert a piece of wooden dowel stock or plastic rod to keep the crankshaft from turning. Don't put anything into the engine that will hit the piston.

9 KEEP AWAY FROM SILICONE SEAL AND THREAD STICKERS

Silicone sealers usually have a smell like vinegar when they're curing. Vinegar is mostly acetic acid and that causes corrosion.

- The inside of an engine has two kinds of metal in it... aluminum for most of the parts and steel for the crankshaft and bearings.
- Two different kinds of metal will start to corrode if they have some kind of electrolyte between them and a tiny bit of acid will do the job.

- Aluminum corrosion can cause the entire inside of the engine to turn a dark grey or nearly black color. Corroded steel is rust. See above about rust.

10 KEEP IT DRY

While it sounds obvious, keeping water out of your engine isn't as easy as it sounds. Sure, you can dry it out when you've run through some mud or puddles, but how about condensation?

- Changes in temperature can cause moisture in the air to condense inside the engine. This can happen in the winter and summer, so keep your model inside the house, not in the garage.
- Keeping it inside the house also gives you good reason to keep it clean just try to explain oil spots on the carpet when your engine is dripping oil from a just-finished running session.

O.S. ENGINES[®]

LIMITED WARRANTY

Your engine is guaranteed to be free of defects in parts and workmanship for a period of 2 years from the date of purchase when returned for service accompanied by Your proof of purchase. Crash damage and problems caused by neglect or abuse will not be covered under warranty. Damage caused by customer disassembly, tampering, use of substandard fuel, use of incorrect accessories (glow plug, prop, etc.), or any use of the engine for which it is not specifically intended will automatically void the warranty of the engine.

Should your engine require warranty or non-warranty service please return it via UPS or insured Parcel Post to our national servicing facility:

Hobby Services
P.O.Box 4021
1610 Interstate Dr.
Champaign IL 61821
Ph. 217-398-0007

Along with Your engine and proof of purchase date please enclose a complete written explanation detailing the problems. State your name and address clearly.

For repairs not covered under warranty, you must specify whether you wish the charges to be billed C.O.D. or if you wish to be notified of the charges so you can send a check.





***O.S. ENGINES* MFG.CO.,LTD.**

6-15 3-Chome Imagawa Higashisumiyoshi-ku
Osaka 546-0003, Japan TEL. (06) 6702-0225

FAX. (06) 6704-2722

URL: <http://www.os-engines.co.jp>