

---

---

***O.S. ENGINE***

---

---

**MAX-12TZ SERIES**

---

---

### **OWNER'S INSTRUCTION MANUAL**

It is of vital importance, before attempting to operate your engine, to read the general **'SAFETY INSTRUCTIONS AND WARNINGS'** section on pages 2-5 of this booklet and to strictly adhere to the advice contained therein.

- Also, please study the entire contents of this instruction manual, so as to familiarize yourself with the controls and other features of the engine.
- Keep these instructions in a safe place so that you may readily refer to them whenever necessary.
- It is suggested that any instructions supplied with the vehicle, radio control equipment, etc., are accessible for checking at the same time.

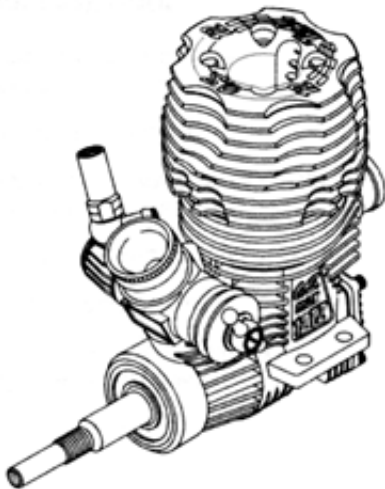

# CONTENTS

SAFETY INSTRUCTIONS AND WARNINGS ABOUT YOUR O.S. ENGINE .....	2-5	FINAL ADJUSTMENT .....	22-25
ENGINE CONSTRUCTION, NOTES WHEN APPLYING AN ELECTRIC STARTER .....	6-7	CARE AND MAINTENANCE, CHECKING THE ENGINE .....	26-27
ABOUT THE ENGINE .....	8	TROUBLE SHOOTING .....	28-31
TOOLS, ACCESSORIES, etc. BASIC ENGINE PARTS .....	9-11	ENGINES, CARBURETORS EXPLODED VIEWS & PARTS LIST .....	32-45
INSTALLATION OF THE STANDARD ACCESSORIES, CARBURETOR CONTROLS 11H, 11H(B), 11M .....	12-14	O.S. GENUINE PARTS & ACCESSORIES .....	46-47
GLOWPLUG, INSTALLATION .....	15-16	THREE VIEW DRAWING .....	48-50
STARTING THE ENGINE & RUNNING-IN ('Breaking-in') .....	17-21	GUARANTEED TO KEEP YOUR R/C CAR RUNNING WELL .....	51-54
		LIMITED WARRANTY .....	55-56

## **SAFETY INSTRUCTIONS AND WARNINGS ABOUT YOUR O.S. ENGINE**

Remember that your engine is not a "toy", but a highly efficient internal-combustion machine whose power is capable of harming you, or others, if it is misused.

As owner, you, alone, are responsible for the safe operation of your engine, so act with discretion and care at all times.

If at some future date, your O.S. engine is acquired by another person, we would respectfully request that these instructions are also passed on to its new owner.

- The advice which follows applies basically to ALL MODEL ENGINES and is grouped under two headings according to the degree of damage or danger which might arise through misuse or neglect.



### **WARNINGS**

These cover events which might involve serious (in extreme circumstances, even fatal) injury.



### **NOTES**

These cover the many other possibilities, generally less obvious sources of danger, but which, under certain circumstances, may also cause damage or injury.



## WARNINGS

- Model engine fuel is poisonous. Do not allow it to come into contact with the eyes or mouth. Always store it in a clearly marked container and out of the reach of children.



- Model engine fuel is also highly flammable. Keep it away from an open flame, excessive heat, sources of sparks, or anything else which might ignite it. Do not smoke or allow anyone else to smoke, near to it.



- Never operate your engine in an enclosed space. Model engines, like automobile engines, exhaust deadly carbon-monoxide. Run your engine only in an open area.

- Model engines generate considerable heat. Do not touch any part of your engine until it has cooled. Contact with the muffler (silencer), cylinder head or exhaust header pipe, in particular, may result in a serious burn.





## NOTES

- This engine is intended for model cars. Do not attempt to use it for any other purpose.
- Mount the engine in your model securely, following the manufacturers' recommendations, using appropriate screws and locknuts.
- Install an effective silencer (muffler). Frequent close exposure to a noisy exhaust (especially in the case of the more powerful highspeed engines) may eventually impair your hearing and such noise is also likely to cause annoyance to others over a wide area.
- The wearing of safety glasses is also strongly recommended.
- Take care that the glowplug clip or battery leads do not come into contact with rotating parts. Also check that the linkage to the throttle arm is secure.
- For their safety, keep all onlookers (especially small children) well back (at least 20 feet or 6 meters) when preparing your model for running.



## NOTES

- Before starting the engine, always check the tightness of all the screws and nuts especially those of joint and movable parts such as throttle arm. Missing retightening the loose screws and nuts often causes the parts breakage that is capable of harming you.
- To stop the engine, fully retard the throttle stick and trim lever on the trans-mitter, or, in an emergency, cut off the fuel supply by pinching the fuel delivery line from the tank.
- Warning! Immediately after a glowplug-ignition engine has been run and is still warm, conditions sometimes exist whereby it is just possible for the engine to abruptly restart if it is rotated over compression WITHOUT the glowplug battery being reconnected.

## ENGINE CONSTRUCTION

With this engine, the piston will feel tight at the top of its stroke (TDC) when the engine is cold. This is normal. The cylinder bore has a slight taper. The piston and cylinder are designed to achieve a perfect running clearance when they reach operating temperature.

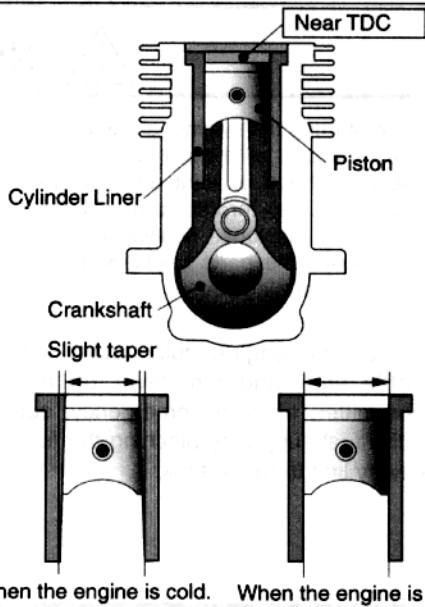

## NOTES WHEN APPLYING AN ELECTRIC STARTER

Do not over-prime. This could cause a hydraulic lock and damage the engine on application of the electric starter.

If over-primed, remove glowplug, close needle-valve and apply starter to pump out surplus fuel. Cover the head with a rag to prevent pumped out fuel getting into your eyes.

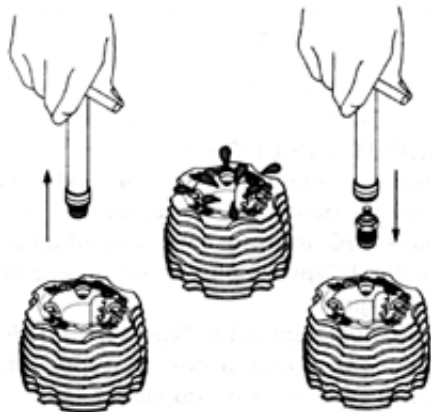



## MAX-12TZ SERIES INSTRUCTIONS

This manual handles the following four versions.

MAX-12TZ(P)-T3 with 11H carburetor

MAX-12TZ(S)-T3 with 11M carburetor

MAX-12TZ-T3 with 11M carburetor

MAX-12TZ(P)-T5 with 11H(B) carburetor

### ABOUT THE ENGINE

These engines are rear exhaust engines designed expressly for 1/10 class R/C touring cars and stadium trucks. T-Type P6 plus is supplied with the engine.

Also, dual adjustable Type 11H, 11H(B) slide valve carburetor or Type 11M barrel carburetor is supplied.

The engines develop enormous torque from the low r.p.m. and offer improved fuel consumption and durability.

Big diameter heatsink head has improved cooling efficiency.

#### Standard accessories

- Glow Plug P6 T-type head (Turbo head) 1piece (Hot Type)



- Exhaust Seal Ring 1piece



-----  
For MAX-12TZ(P)-T5 only

- Carburetor Reducer 6.5mm (Gray) 1piece (w/ "O" Ring)



#### NOTE

As delivered, the engine has the carburetor lightly fit into its intake. Secure it changing its angle and outer head position according to the car chassis.

## TOOLS, ACCESSORIES, etc.

The following items are necessary for operating the engine.

### ■ Items necessary for starting

#### FUEL

Generally, it is suggested that the user selects a fuel that is commercially available for model two-stroke engines and contains 10-30% nitromethane. As a starting point, we recommend a fuel containing 20% nitromethane, changing to a fuel containing more nitro if necessary. When the brand of fuel is changed, or the nitro content increased, it is advisable to repeat the running-in procedure referred to in the RUNNING-IN paragraphs. Please note that with high-nitro fuels, although power may be increased for competition purposes, glowplug elements do not last as long and engine life will be shortened.



#### REMINDER!

 Model engine fuel is poisonous. Do not allow it to come into contact with the eyes or mouth. Always store it in a clearly marked container and out of the reach of children.

 Model engine fuel is also highly flammable. Keep it away from open flame, excessive heat, sources of sparks, or anything else which might ignite it. Do not smoke or allow anyone else to smoke, near to it.

#### FUEL FILTER

To be installed in the fuel line between fuel tank and carburetor to prevent dust from entering the carburetor.



#### GLOWPLUG IGNITER

Commercially available handy glowplug heater in which the glowplug battery and battery leads are integrated.



#### STARTER BOX

For starting the engine.



## 7.2V BATTERIES FOR STARTER BOX

Batteries for starter box. Select according to the starter box used. Be sure to full charge before using.



## FUEL PUMP

For filling the fuel tank, a simple, polyethylene "squeeze" bottle, with a suitable spout, is required.



## SILICONE FUEL LINE

Heatproof silicone tubing of approx. 5mm o.d. and 2mm i.d. is required for the connection between the fuel tank and engine.



## ■ TOOLS

### HEX SCREWDRIVER

Necessary for engine installation.  
1.5mm, 2mm, 2.5mm, 3mm



### SCREWDRIVER

Necessary for carburetor adjustments.  
No.1, No.2, etc



### SOCKET DRIVER

It is required to tighten and loosen the carburetor retainer nut. Opposite side distance of 6mm



### LONG SOCKET WRENCH WITH PLUG GRIP

Recommended for easy removal and replacement of the angled and recessed glowplug, the O.S.Long Socket Wrench incorporates a special grip.

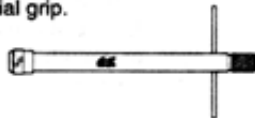

## BASIC ENGINE PARTS

MAX-12TZ(P)-T3

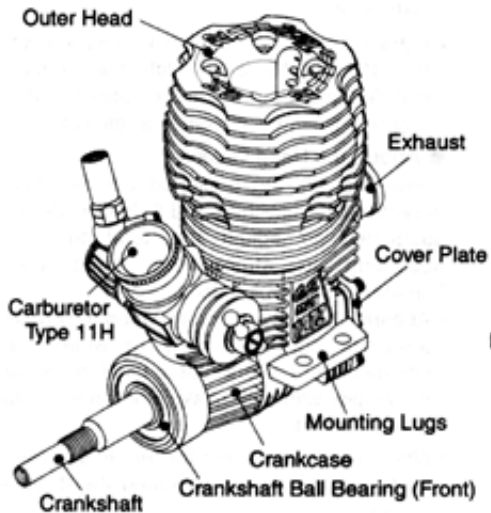

MAX-12TZ-T3

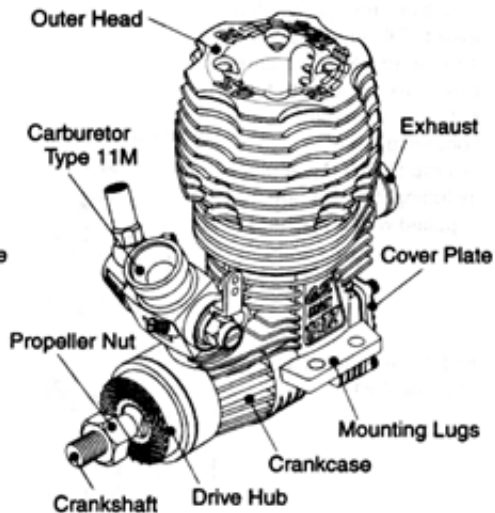

## INSTALLATION OF THE STANDARD ACCESSORIES

Installing the glow plug. Insert P6 plug supplied into heatsink-head carefully, making sure that it is not cross-threaded before tightening firmly.

(All the O.S. T-Type plugs including the P6 are not supplied with a washer.)

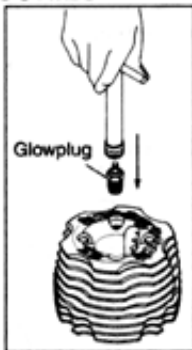

Install the exhaust seal ring supplied.

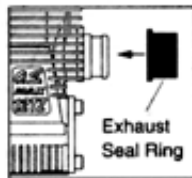

### Installing the carburetor reducer

- 5.5mm (Black) bore reducer is installed on both the 12TZ(P)-T3 and 12TZ(P)-T5 carburetor.
- Extra 6.5mm bore reducer is supplied with the 12TZ(P)-T5 only. With this reducer installed, more power can be obtained, while engine adjustment becomes a little critical

### ■ About the Head Gasket

These engines are equipped with two head gaskets of 0.1mm thick and 0.2mm thick. It is suggested to adjust the total thickness according to atmospheric temperature, humidity and glowplug used.

- At early stage of running-in, when a glowplug tends to burn out early or when high nitromethane content fuel is used, try to run the engine with both gaskets or removing the 0.1mm gasket.
- When low nitromethane content fuel is used, try to run the engine removing the 0.2mm gasket.

## CARBURETOR CONTROLS 11H, 11H(B)

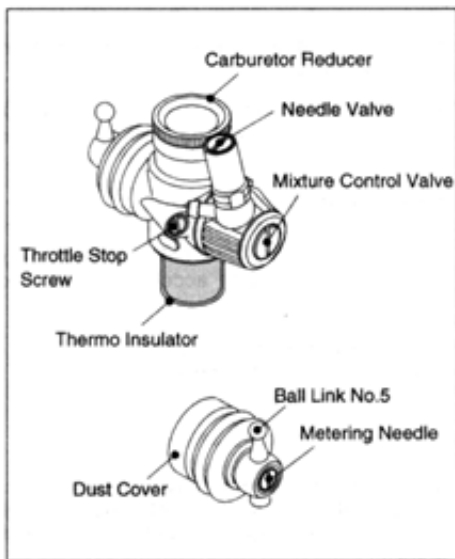

Four adjustable controls are provided on this carburetor.

- **The Needle-Valve(Adjusted at the factory):**

For adjusting the mixture strength when the throttle is fully open.

- **The Mixture Control Valve:**

For changing the mixture strength at mid speed and acceleration. (Do not rotate the screw more than one turn.)

- **The Metering Needle:**

For adjusting the mixture strength at part-throttle and idle speed, to obtain steady idling and smooth acceleration to mid speed.

- **The Throttle Stop Screw (Adjusted at the factory):**

For setting the minimum idle speed:

**NOTE:** Readjustment may be necessary, occasionally to allow for changes in fuel formula, gear ratio or clutch engagement point.

## CARBURETOR CONTROLS 11M

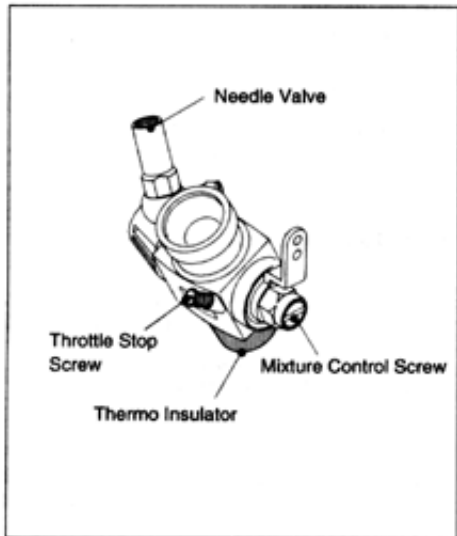

Three adjustable controls are provided on this carburetor.

- **The Needle-Valve(Adjusted at the factory):**  
For adjusting the mixture strength when the throttle is fully open.
- **The Mixture Control Screw:**  
For adjusting the mixture strength at part-throttle and idle speed, to obtain steady idling and smooth acceleration to mid speed.
- **The Throttle Stop Screw (Adjusted at the factory):**  
For setting the minimum idle speed:

**NOTE:** Readjustment may be necessary, occasionally to allow for changes in fuel formula, gear ratio or clutch engagement point.

---

## GLOWPLUG

Since the compatibility of the glowplug and fuel may have a marked effect on performance and reliability, it is suggested to use the O.S. P6 plug when it is necessary to replace. Carefully install plug finger-tight, before final tightening with the correct size plug wrench.

### The role of the glowplug

With a glowplug engine, ignition is initiated by the application of a 1.5-volt power source. When the battery is disconnected, the heat retained within the combustion chamber remains sufficient to keep the plug filament glowing, thereby continuing to keep the engine running. Ignition timing is 'automatic': under reduced load, allowing higher rpm, the plug becomes hotter and, appropriately, fires the fuel/air charge earlier; conversely, at reduced rpm, the plug become cooler and ignition is retarded.

### Glowplug life

Particularly in the case of very high performance engines, glowplugs must be regarded as expendable items. However, plug life can be extended and engine performance maintained by careful use, i.e.:

- Install a plug suitable for the engine.
- Use fuel containing a moderate percentage of nitromethane unless more is essential for racing events.
- Do not run the engine too lean and do not leave the battery connected while adjusting the needle.

### When to replace the glowplug

Apart from when actually burned out, a plug may need to be replaced because it no longer delivers its best performance, such as when:

- Filament surface has roughened and turned white.
- Filament coil has become distorted.
- Foreign matter has adhered to filament or plug body has corroded.
- Engine tends to cut out when idling.
- Starting qualities deteriorate.



## INSTALLATION OF THE CARBURETOR

As delivered, the engine has its carburetor lightly fit into the intake boss. Secure it as follows.

1. Loosen the retainer screw, rotate the carburetor to its correct position and make sure that it is pressed well down into the intake boss, compressing the rubber gasket, before retightening screw.
2. Rotate the retainer screw gently until it stops, then tighten a further 60-90°. Do not overtighten the screw as this will damage the carburetor body.

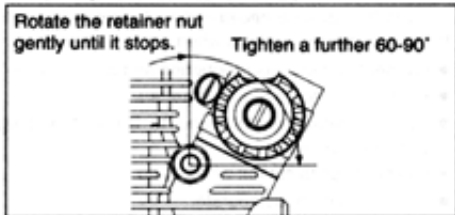

## ENGINE INSTALLATION

Make sure that the vehicle's engine mounting surfaces are level and in the same plane. Poor installation may cause distortion of the crankcase, bearings, etc., resulting in erratic running and loss of performance.

The recommended screws for securing the engine are 3mm or 4-40 steel Allen hexagon socket type.

If existing holes in the engine mount do not align perfectly with engine mounting lugs, enlarge them slightly with a needle-file so that screws are in alignment with the mounting holes.

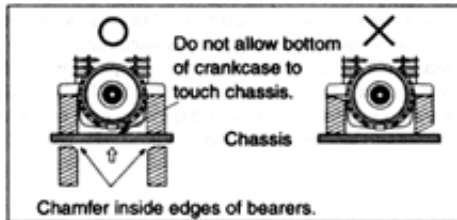

---

## STARTING THE ENGINE & RUNNING-IN ('Breaking-in)

Lay the chassis on a stand and start the engine so that the tiers may not be in contact with the ground.

### PRESSURIZED FUEL SYSTEM

- The somewhat violent changes of vehicle attitude that occur in off-road running, combined with the fact that, in buggy type cars, the fuel tank is often located some distance from the carburetor, means that fuel 'head' at the carburetor can vary and upset running. Therefore, it is recommended that a muffler pressurized fuel feed system be used.
- Never run your vehicle without installing the air cleaner. Dust and dirt that may otherwise be drawn into the engine will rapidly shorten its life.

Running-in is a procedure for an engine to come close to actual running conditions (fuel, r.p.m., engine temperature, etc.).

Excessively rich running and prolonged low speed running mean nothing. Prolonged low speed running and low temperature running may result in the oil in the fuel being gelled and piston/liner being agglutinated.

Try to make time to run the car at full throttle. Lengthen full throttle running time gradually. When the car can run full throttle with rich mixture at the straight, close the needle-valve a little. Repeat this procedure until the car runs at the maximum speed at the latter straight course.

 Before starting the engine, always check the tightness of all the screws and nuts especially those of joint and movable parts such as throttle arm. Missing retightening the loose screws and nuts often causes the parts breakage that is capable of harming you.

The following procedure is suitable for these engines when the O.S. T-1040 tuned silencer and a fuel containing up to 30% nitromethane are used.

- ◆ Fill the tank completely with fuel.
- ◆ Temporarily remove the glowplug to check that it glows bright red when energized.

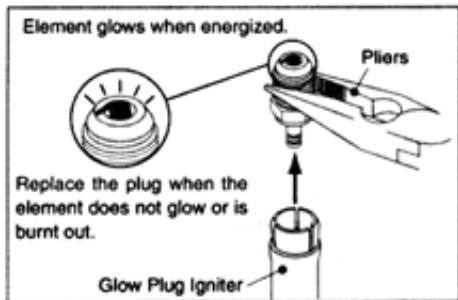

11H, 11H(B) carburetor is set as shown below at the factory. Start the engine as it is.

- ◆ The needle-valve is set approx. 1-3/4 turns opened from the fully closed position.

Turn the needle-valve clockwise until it stops. This is the fully closed position. Do not force it to turn further.



- ◆ Throttle is set approx. 0.5mm open.

Approx. 0.5mm open  
factory setting with the  
reducer removed

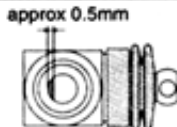

- ◆ Metering needle and mixture control valve are set at basic position.

**11M carburetor is set as shown below at the factory. Start the engine as it is.**

- ◆ The needle-valve is set approx. 1-3/4 turns opened from the fully closed position.
- ◆ Throttle is set approx. 1mm open.

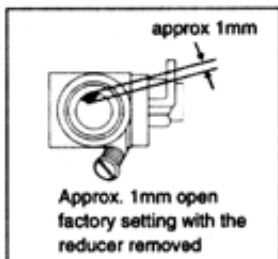

- ◆ Mixture control Screw are set at basic position.

- ◆ Switch on the transmitter and make sure that each linkage moves correctly.
- ◆ Turn the engine with starter box to draw the fuel into the engine.



- ◆ Now connect glowplug battery lead to heat the plug filament and start the engine.
- ◆ When the engine starts, first allow it to operate in short runs at the very rich starting settings, with the glowplug battery still connected and the driving wheels clear of the ground. The rich mixture will, under these conditions, provide adequate lubrication and cooling, indicated by profuse smoke from the exhaust.



**Attention:**

It is vitally important to set the throttle at the correct position before starting the engine. If the engine is allowed to run with the throttle too far open under "no load" conditions (i.e. with the driving wheels not in contact with the ground) it will rapidly over-heat and may be seriously damaged.

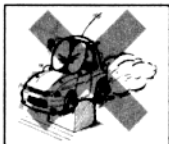

- ◆ Next, disconnect the glowplug battery and try running the car on the track. If the engine stalls, open the throttle fractionally, but try to keep the engine running as rich as possible: if it stops because of being excessively over-rich, close the Needle-Valve 15° and try again.

- ◆ Run the car on the track until one tank of fuel has been consumed, then close the Needle-Valve 15° and run the car for 3 to 5 full tanks of fuel. Repeat this procedure until approx. 2 liters of fuel have been consumed, during which time the throttle may be opened for brief bursts of increased power. If the engine stops at medium speeds, turn the Mixture Control Screw (in case of the 11M) or the Mixture Control Valve (in case of the 11H, 11H(B)) 45°.

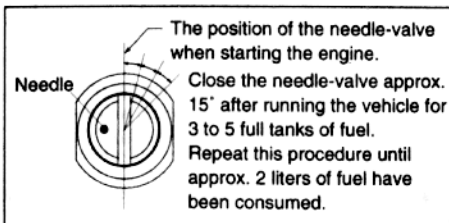

**Note:**

If the engine should need to be disassembled (e.g. for cleaning or minor parts replacement), it is advisable to return the needle-valve to the original rich, starting setting and check whether further running-in time is required before the car is raced again. In the event of any major working parts (e.g. piston/cylinder liner assembly) being replaced or the fuel being changed, especially to high nitro fuel, the complete running-in should be repeated.

- ◆ To stop the engine, close the throttle to idle speed, then shut it off completely with the trim lever on the transmitter. To cut off the fuel supply, pinch the fuel delivery tube to the carburetor.

**Warning!**

Do not touch rotating parts, engine and silencer when stopping the engine as they become very hot, and contact with them may result in a serious burn.

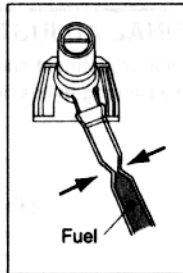

## FINAL ADJUSTMENT

Final adjustment should be carried out only after the running-in has been completed.

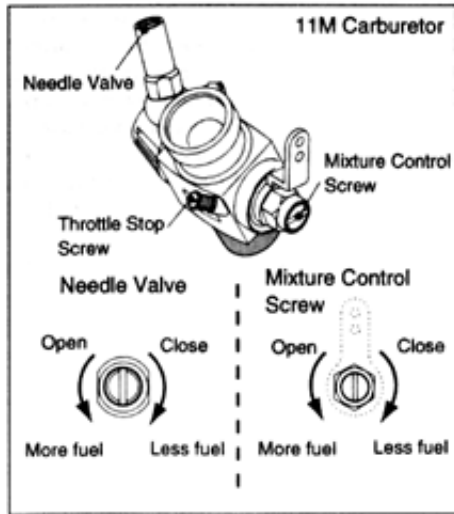
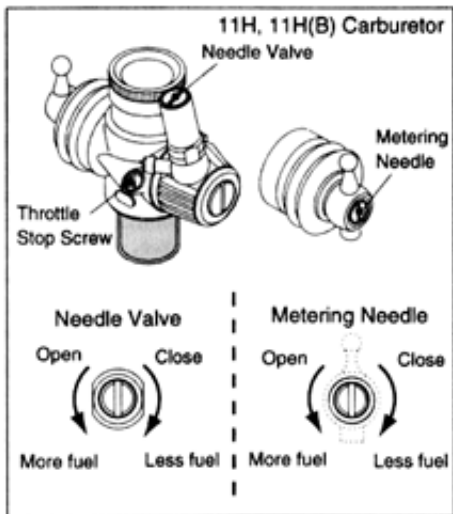

- ◆ Run the vehicle (with throttle fully open) over the longest available straight course, in order to observe the model's speed. Next return the car to the starting point, close the Needle-Valve 15° and repeat the run, taking note of the improvement in performance.
- ◆ Continue with further runs, gradually reducing the Needle-Valve setting and aiming to achieve the highest straight-line speed. Remember, however, that, if the Needle-Valve is shut down too far, the engine will overheat and, accompanied by visibly diminished exhaust smoke, the model will lose speed. At this point, throttle down immediately, stop the vehicle and reopen the Needle-Valve 15°.
- ◆ With the engine running, close the throttle and allow it to idle for about five seconds, then reopen the throttle fully. If, at this point, the engine puffs out an excessive amount of smoke and the vehicle does not accelerate smoothly and rapidly, it is probable that the idle mixture is too rich.
- ◆ In this case, turn the Mixture Control Screw (in case of the 11M) or the Metering Needle (in case of the 11H, 11H(B)) 15°. If, on the other hand, the engine tends to speed up momentarily and then cut out abruptly when the throttle is opened, the idle mixture is too lean. Correct this by turning the Mixture Control Screw (in case of the 11M) or the Metering Needle (in case of the 11H, 11H(B)) 15°.
- ◆ Carry out adjustments patiently, under actual running conditions, until the engine responds quickly and positively to the throttle control.



## **Warning!**

**Mixture adjustments (whether via the Metering Needle, or the Needle-Valve) cannot be made accurately under 'no-load' conditions, which, in any case, are not advised, since such operation carries the risk of seriously damaging the engine through over-revving and overheating.**

- ◆ With the optimum mixture control position, light smoke is visible during high speed running, and the engine rpm increases smoothly during acceleration. Remember that, if the engine is operated with the fuel/air mixture slightly too lean, it will overheat and run unevenly. As with all engines, it is advisable to set both the Mixture control screw, needle-valve and metering needle slightly on the rich side of the best rpm setting, as a safety measure.

- ◆ If the engine runs too fast with the throttle closed, the throttle stop screw should be turned counter-clockwise to allow the throttle opening to be reduced.
- ◆ Finally, beyond the nominal break-in period, a slight readjustment toward a leaner needle setting may be required to maintain maximum performance.

## ■ REALIGNMENT OF METERING NEEDLE AND MIXTURE CONTROL VALVE

In the course of making carburetor adjustments, it is just possible that the Metering Needle and the Mixture Control Valve may be inadvertently screwed in or out too far and thereby moved beyond its effective adjustment range.

The basic positions can be found by rotating the Metering Needle until its slotted head is flush with the ball link body.

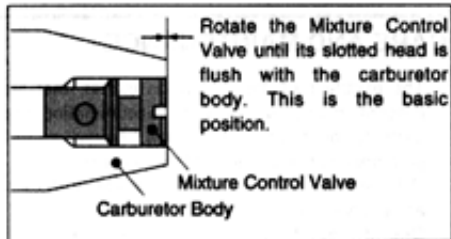
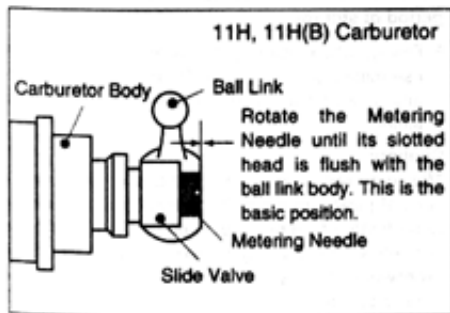

## ■ REALIGNMENT IS MIXTURE CONTROL SCREW

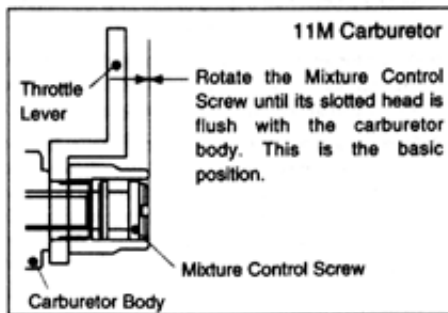

---

## CARE AND MAINTENANCE

1. The minute particles of foreign matter, that are present in any fuel may, by accumulating and partially obstructing fuel flow, cause engine performance to become erratic and unreliable.

O.S. 'Super-Filters' (large and small) are available, as optional extras, to deal with this problem.

One of these filters installed to the pickup tube inside your refueling container, will prevent the entry of foreign material into the fuel tank. It is also recommended that a good in-line filter be installed between the tank and carburetor.

2. Do not forget to clean the filters regularly to remove dirt and lint that accumulate on the filter screens. Also, clean the carburetor itself occasionally.
3. At the end of each operating session, drain out any fuel that may remain in the fuel tank. Afterwards, energize the glow-plug and try to restart the engine, to burn off any fuel that may remain inside the engine. Repeat this procedure until the engine fails to fire. Do this while the engine is still warm.

4. Then, inject some after-run oil into the engine, and rotate the engine with an electric starter for 4 to 5 seconds to distribute the oil to all the working parts.

### Note:

**Do not inject after-run oil into the carburetor as this may cause the O-rings inside the carburetor to deteriorate. These procedures will reduce the risks of starting difficulties or corrosion after a period of storage.**

5. Finally, when cleaning the exterior of the engine, use methanol or kerosene. Do not use gasoline or any solvent that might damage the silicone fuel tubing.

### Caution:

**The rear crankshaft bearing of this engine uses a special plastic retainer. If the front housing needs to be heated to remove or replace the bearing, do not allow the bearing to exceed 120°C (248°F), otherwise it may be damaged and rendered unserviceable.**

Dirt and dust may lodge in ○ marked places.



■ **Installing Dust Caps** (Optional extra)

When storing the engine, install the cap on the exhaust port, carburetor, etc. to prevent dust from entering the engine.

---

## CHECKING THE ENGINE

If the engine suffers a loss of performance after a long period of running it may be due to the wearing of parts. It is suggested that the worn parts be replaced when the following symptoms are detected.

- ◆ Engine sound changes and easily overheats.
- ◆ Power has dropped considerably.
- ◆ Idle is unstable and/or engine tends to stop at idle.

In most cases, ball bearings, cylinder & piston assembly, connecting rod and/or crankcase have become worn out or abnormal. Check the parts carefully and replace them if necessary.

## TROUBLE SHOOTING

Symptom	
Engine fails to fire.	
Cause	Corrective action
Fuel tank is empty. Fuel not reaching the engine.	Fill the tank with fuel and repeat Priming procedure.
Glowplug element is burnt out. Glowplug battery discharged	Replace glowplug. Recharge or replace the battery.
Clogged fuel filter Air cleaner and silencer inside is dirty.	Clean or replace fuel filter. Replace cleaner element and clean inside silencer.
Over priming	Remove glowplug and pump excess fuel.
Fuel tubing is disconnected. Fuel tubing is kinked, split or has a hole.	Connect fuel tubing securely. Check the tubing carefully and replace if necessary.
Incorrect servo linkage	Connect correctly after setting servo at neutral.
Reverse rotating direction of starter box.	Make sure it rotates counter clockwise seen from crankshaft side.

<b>Symptom</b>	
<b>Engine fires intermittently but does not run.</b>	
<b>Cause</b>	<b>Corrective action</b>
Insufficient fuel in the tank.	Fill the tank with fuel.
Deteriorated glowplug	Replace glowplug.
Clogged fuel filter Air cleaner and silencer inside is dirty.	Clean or replace fuel filter. Replace cleaner element and clean inside silencer.
Engine overheated	Wait until engine is cool.
Incorrect clutch release	Adjust the tension of clutch spring.
Starting battery disconnected too soon.	Do not disconnect plug battery and wait until r.p.m. become stable.
Vibration causing air bubbles in fuel.	Install "O" rings to the tank screws to prevent bubbles.

<b>Symptom</b>	
<b>Unstable idle</b>	
<b>Cause</b>	<b>Corrective action</b>
Unsuitable glowplug	Use suggested glowplug in the instructions.
Unsuitable fuel	Do not use extremely high nitro or low oil content fuel.
Extremely light flywheel	Add suitable load.
Silencer is disconnected or has play	Install silencer securely.
<b>Symptom</b>	
<b>Not reaching expected peak r.p.m.</b>	
<b>Cause</b>	<b>Corrective action</b>
Insufficient warming up or running-in.	Set the needle only after warming up. Complete running-in.
Silencer or manifold is not securely connected or disconnected.	Replace seal ring. Check the connections and secure them.
Fuel tubing from tank is split or broken.	Replace the tubing.

<b>Symptom</b>	
<b>Poor response</b>	
<b>Cause</b>	<b>Corrective action</b>
Deteriorated glowplug	Replace glowplug.
Incorrect carburetor settings	Readjust low r.p.m. range with metering needle and mixture control valve.
Incorrect setting of transmitter Exponential function.	Check the transmitter setting.
Incorrect linkage	Make sure that throttle servo does not interfere servo linkage.
<b>Symptom</b>	
<b>Poor r.p.m. drop</b>	
<b>Cause</b>	<b>Corrective action</b>
Throttle position open too far.	Close the throttle stopper or rotor adjusting screw to lower the idling r.p.m.
carburetor not fully seated	Install carburetor securely.
Metering needle closed too far.	Open the metering meedle a little.



## MAX-12TZ (P)-T3 ENGINE EXPLODED VIEW

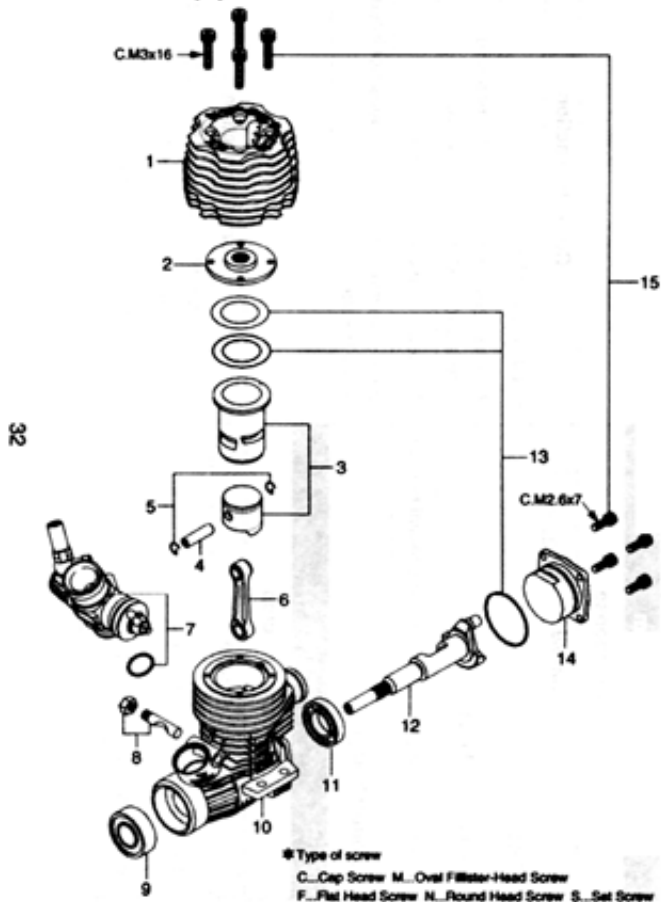

## MAX-12TZ (P)-T3 ENGINE PARTS LIST

No.	Code No.	Description
1	21534000	Outer Head (Blue)
2	21534100	Inner Head
3	21533000	Cylinder & Piston Assembly
4	21536000	Piston Pin
5	21817000	Piston Pin Retainer (2pcs.)
6	21535000	Connecting Rod
7	21538000	Carburetor Complete (Type 11H)
8	25381701	Carburetor Retainer Assembly
9	22631020	Crankshaft Ball Bearing (Front)
10	21531000	Crankcase
11	21931000	Crankshaft Ball Bearing (Rear)
12	21532000	Crankshaft
13	21531400	Gasket Set
14	21917000	Cover Plate
15	23763000	Screw Set
	71641600	Glow Plug P6
	21427200	Exhaust Seal Ring

The specifications are subject to alteration for improvement without notice.

## 11H CARBURETOR EXPLODED VIEW

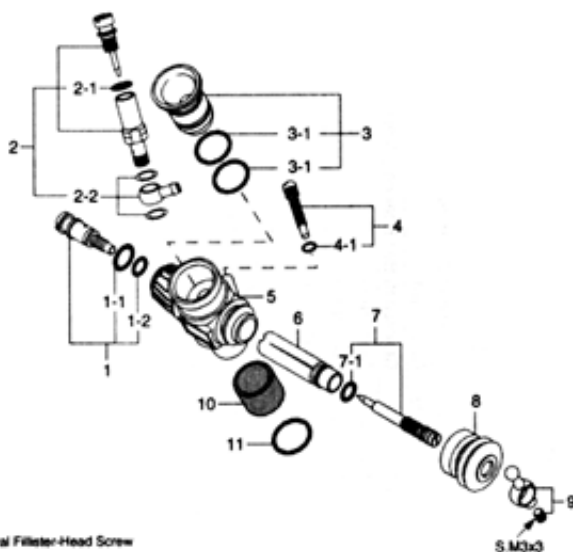

\* Type of screw

C...Cap Screw M...Oval Filister-Head Screw  
 F...Flat Head Screw N...Round Head Screw S...Set Screw

34

## 11H CARBURETOR PARTS LIST

No.	Code No.	Description
1	21982600	Mixture Control Valve Assembly
1-1	27881820	"O" Ring(L) (2pcs.)
1-2	22781800	"O" Ring(S) (2pcs.)
2	21982970	Needle Valve Assembly
2-1	27881820	"O" Ring (2pcs.)
2-2	21881950	No.14 Universal Nipple Assembly
3	71533055	Carburetor Reducer (5.5mm, Black)
3-1	22615000	"O" Ring
4	21982620	Throttle Stop Screw
4-1	22781800	"O" Ring(S) (2pcs.)
5	21538100	Carburetor Body (w/Thermo Insulator)
6	21982200	Slide Valve
7	21538500	Metering Needle Assembly
7-1	22781800	"O" Ring(S) (2pcs.)
8	21982520	Dust Cover
9	23818430	Ball Link No.5
10	21982900	Thermo Insulator
11	22615000	Carburetor Rubber Gasket

The specifications are subject to alteration for improvement without notice.

35

## MAX-12TZ -T3 ENGINE EXPLODED VIEW

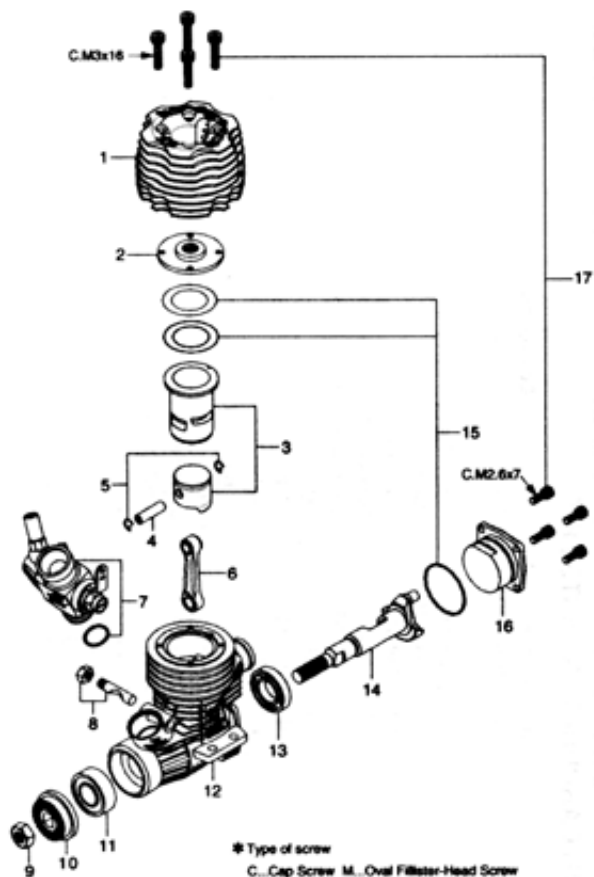

## MAX-12TZ -T3 ENGINE PARTS LIST

No.	Code No.	Description
1	21534000	Outer Head (Blue)
2	21534100	Inner Head
3	21533000	Cylinder & Piston Assembly
4	21536000	Piston Pin
5	21817000	Piston Pin Retainer (2pcs.)
6	21535000	Connecting Rod
7	21484010	Carburetor Complete (Type 11M)
8	25381701	Carburetor Retainer Assembly
9	20810007	Propeller Nut
10	21458000	Drive Hub
11	22631020	Crankshaft Ball Bearing (Front)
12	21531000	Crankcase
13	21931000	Crankshaft Ball Bearing (Rear)
14	21532030	Crankshaft
15	21531400	Gasket Set
16	21917000	Cover Plate
17	23763000	Screw Set
	71641600	Glow Plug P6
	21427200	Exhaust Seal Ring

The specifications are subject to alteration for improvement without notice.

## MAX-12TZ(S) -T3 ENGINE EXPLODED VIEW

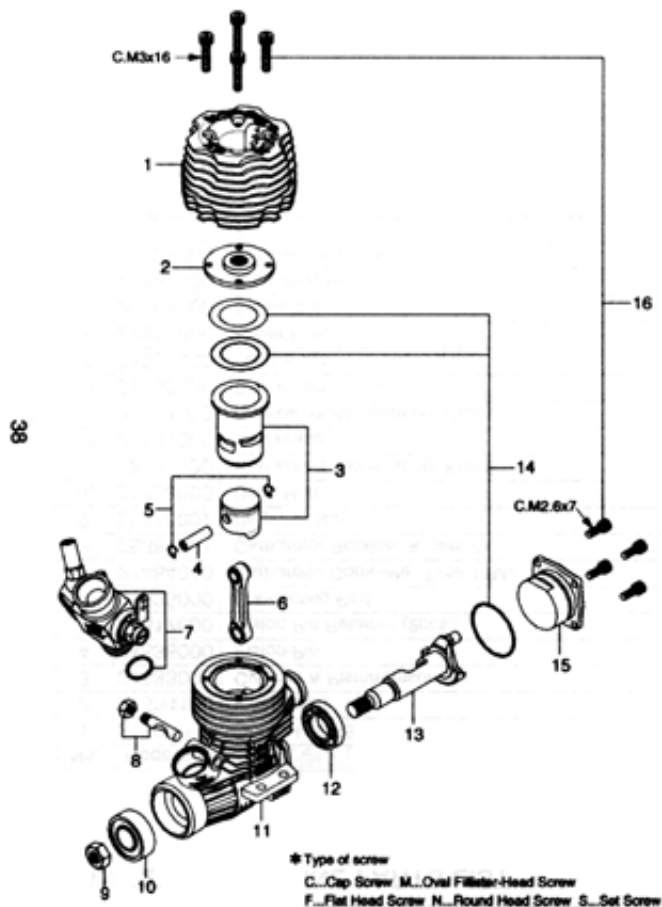

## MAX-12TZ(S) -T3 ENGINE PARTS LIST

39

No.	Code No.	Description
1	21534000	Outer Head (Blue)
2	21534100	Inner Head
3	21533000	Cylinder & Piston Assembly
4	21536000	Piston Pin
5	21817000	Piston Pin Retainer (2pcs.)
6	21535000	Connecting Rod
7	21484010	Carburetor Complete (Type 11M)
8	25381701	Carburetor Retainer Assembly
9	20810007	Propeller Nut
10	22631020	Crankshaft Ball Bearing (Front)
11	21531000	Crankcase
12	21931000	Crankshaft Ball Bearing (Rear)
13	21532050	Crankshaft
14	21531400	Gasket Set
15	21917000	Cover Plate
16	23763000	Screw Set
	71641600	Glow Plug P6
	21427200	Exhaust Seal Ring

The specifications are subject to alteration for improvement without notice.

## 11M CARBURETOR EXPLODED VIEW

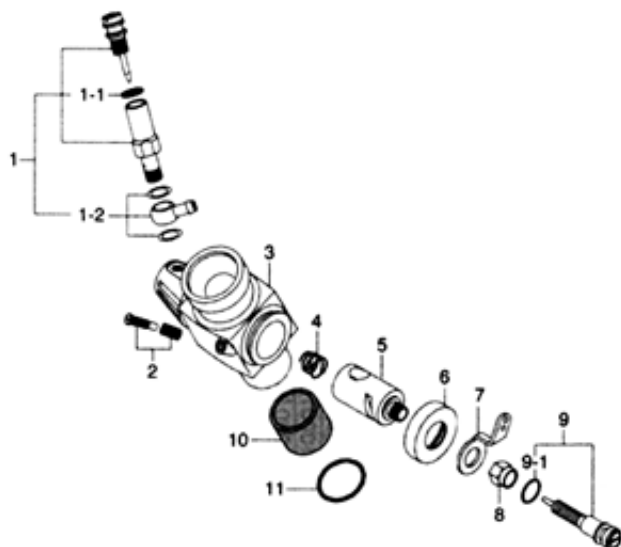

40

## 11M CARBURETOR PARTS LIST

No.	Code No.	Description
1	21285901	Needle Valve Assembly
1-1	27881820	*O* Ring (2pcs.)
1-2	21881950	No. 14 Universal Nipple Assembly
2	22681310	Throttle Stop Screw
3	21484110	Carburetor Body (w/Thermo Insulator)
4	22481506	Rotor Spring
5	21484200	Carburetor Rotor
6	21283210	Dust Cover
7	22681419	Throttle Lever
8	21481420	Throttle Lever Fixing Nut
9	21484600	Mixture Control Screw
9-1	27881820	*O* Ring (2pcs.)
10	21165010	Thermo Insulator
11	22615000	Carburetor Rubber Gasket

The specifications are subject to alteration for improvement without notice.

## MAX-12TZ (P)-T5 ENGINE EXPLODED VIEW

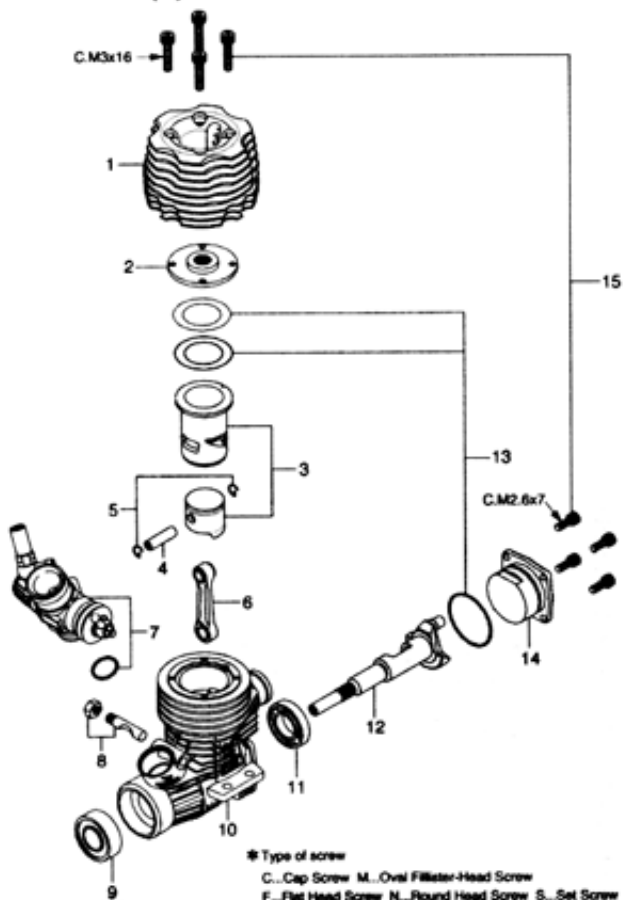

42

## MAX-12TZ (P)-T5 ENGINE PARTS LIST

No.	Code No.	Description
1	21534010	Outer Head (Silver)
2	21534100	Inner Head
3	21533010	Cylinder & Piston Assembly
4	21536000	Piston Pin
5	21817000	Piston Pin Retainer (2pcs.)
6	21535000	Connecting Rod
7	21538010	Carburetor Complete (Type 11H (B))
8	25381701	Carburetor Retainer Assembly
9	22631020	Crankshaft Ball Bearing (Front)
10	21531010	Crankcase (Black)
11	21931000	Crankshaft Ball Bearing (Rear)
12	21532010	Crankshaft
13	21531400	Gasket Set
14	21537000	Cover Plate
15	23763000	Screw Set
	71641600	Glow Plug P6
	21427200	Exhaust Seal Ring
	71533055	Carburetor Reducer 6.5mm (Gray)

43

The specifications are subject to alteration for improvement without notice.

## 11H (B) CARBURETOR EXPLODED VIEW

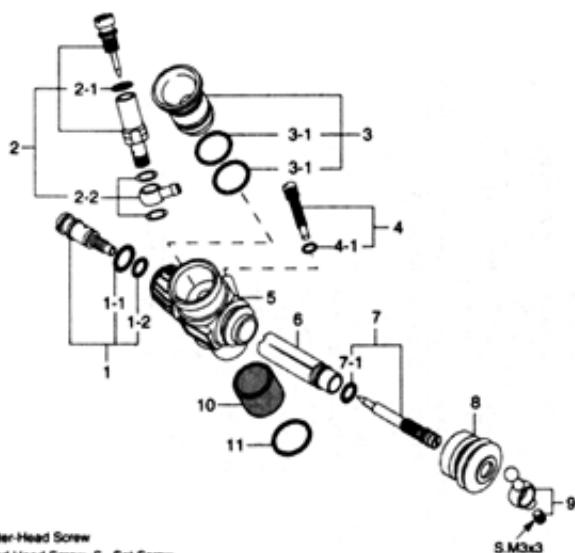

★ Type of screw

C...Cap Screw M...Oval Fillet-Head Screw

F...Flat Head Screw N...Round Head Screw S...Set Screw

44

## 11H (B) CARBURETOR PARTS LIST

No.	Code No.	Description
1	21982600	Mixture Control Valve Assembly
1-1	27881820	"O" Ring(L) (2pcs.)
1-2	22781800	"O" Ring(S) (2pcs.)
2	21982970	Needle Valve Assembly
2-1	27881820	"O" Ring (2pcs.)
2-2	21881950	No.14 Universal Nipple Assembly
3	71533055	Carburetor Reducer (5.5mm, Black)
3-1	22615000	"O" Ring
4	21982620	Throttle Stop Screw
4-1	22781800	"O" Ring(S) (2pcs.)
5	21538110	Carburetor Body (Black, w/Thermo Insulator)
6	21982200	Slide Valve
7	21538500	Metering Needle Assembly
7-1	22781800	"O" Ring(S) (2pcs.)
8	21982520	Dust Cover
9	23818430	Ball Link No.5
10	21982900	Thermo Insulator
11	22615000	Carburetor Rubber Gasket
	71533065	Carburetor Reducer (6.5mm, Gray)

The specifications are subject to alteration for improvement without notice.

45

## O.S. GENUINE PARTS & ACCESSORIES

**ASAP**  
RACING ENGINE PARTS

### ■ O.S. Glow Plug



- **P6** (71641600)
- **P7** (71641700)
- **P8** (71641800)

### ■ Exhaust Manifold Assembly

- **M1001** (72106420)  
Left side exhaust,  
Joint tube type
  - Manifold Spring (72106172)
- **M1010** (72103180)  
Right side exhaust,  
Joint tube type
  - Manifold Spring (72106172)

- **M1001SC** (72106400)  
Left side exhaust,  
Spring connect type
  - Manifold Spring (72106172)
- **M1011SC** (72106410)  
Right side exhaust,  
Spring connect type
  - Manifold Spring (72106172)

### ■ Super Joint Tube 15



(72103310)

### ■ Tuned Silencer

#### ■ Joint tube type

- **T-1040 L52** Left side exhaust (72103051)
- **T-1040 L70** Left side exhaust (72103071)
- **T-1040 R52** Right side exhaust (72103056)
- **T-1040 R70** Right side exhaust (72103076)

#### ■ Spring connect type

- **T-1040SC L52**  
Tuned Silencer Assembly (72106310) Left side exhaust
  - Tuned Silencer Body (72106311)
  - Exhaust Seal Ring (2pcs.) (22826140)
  - Joint Spring (3pcs.) (72106042)

- **T-1040SC R52**  
Tuned Silencer Assembly (72106320) Right side exhaust
  - Tuned Silencer Body (72106321)
  - Exhaust Seal Ring (2pcs.) (22826140)
  - Joint Spring (3pcs.) (72106042)

46

## O.S. GENUINE PARTS & ACCESSORIES

**ASAP**  
RACING ENGINE PARTS

### ■ T-1040SC L52 Complete Set (72106500)

- **T-1040SC L52**  
Tuned Silencer Assembly (72106310)
- **M1001SC**  
Exhaust Manifold Assembly (72106400)
- Exhaust Seal Ring (2pcs.) (21427200)

### ■ T-1040SC R52 Complete Set (72106510)

- **T-1040SC R52**  
Tuned Silencer Assembly (72106320)
- **M1011SC**  
Exhaust Manifold Assembly (72106410)
- Exhaust Seal Ring (2pcs.) (21427200)

### ■ Super Air Cleaner 202 Assembly (72412000) On-road Type

- 202 Cleaner Body (72412100)
- 202 Filter Element (4pcs.) (72412200)



### ■ Super Air Cleaner 203 Assembly (72413000) Off-road Type

- 203 Filter Element (4pcs.) (72413200)



### ■ Cap Screw Set (10pcs.)

- **M2.6x7** (79871020)



### ■ Dust Cap Set

- **3mm** (5pcs.) (73300305)
- **16mm** (3pcs.) (73301612)



### ■ Long Socket Wrench With Plug Grip (71521000)



The specifications are subject to alteration for improvement without notice.

47



**MAX-12TZ(P)-T3****THREE VIEW DRAWING**

Dimensions (mm)

**SPECIFICATIONS**

■ Displacement	2.11 cc (0.128 cu.in.)
■ Bore	13.8 mm (0.543 in.)
■ Stroke	14.0 mm (0.551 in.)
■ Practical R.P.M.	5,000-40,000 r.p.m.
■ Power output	1.5 ps / 33,500 r.p.m.
■ Weight	224.5g (7.92 oz.)

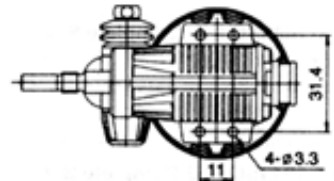
**MAX-12TZ(P)-T5****SPECIFICATIONS**

■ Displacement	2.11 cc (0.128 cu.in.)
■ Bore	13.8 mm (0.543 in.)
■ Stroke	14.0 mm (0.551 in.)
■ Practical R.P.M.	5,000-40,000 r.p.m.
■ Power output	1.62 ps / 34,400 r.p.m.
■ Weight	224.5g (7.92 oz.)

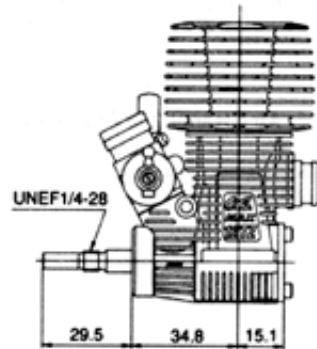
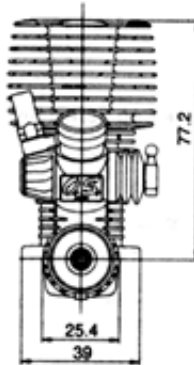

48

**MAX-12TZ-T3****THREE VIEW DRAWING**

Dimensions (mm)

**SPECIFICATIONS**

■ Displacement	2.11 cc (0.128 cu.in.)
■ Bore	13.8 mm (0.543 in.)
■ Stroke	14.0 mm (0.551 in.)
■ Practical R.P.M.	5,000-40,000 r.p.m.
■ Power output	1.5 ps / 33,500 r.p.m.
■ Weight	223.5g (7.89 oz.)

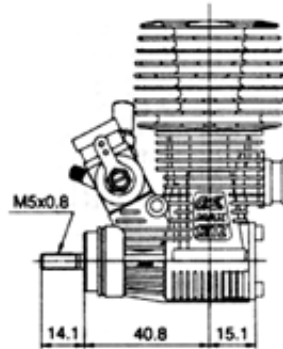
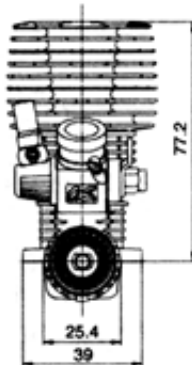
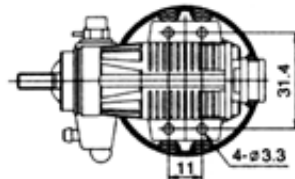

49

**MAX-12TZ(S)-T3****THREE VIEW DRAWING**

Dimensions (mm)

**SPECIFICATIONS**

■ Displacement	2.11 cc (0.128 cu.in.)
■ Bore	13.8 mm (0.543 in.)
■ Stroke	14.0 mm (0.551 in.)
■ Practical R.P.M.	5,000-40,000 r.p.m.
■ Power output	1.5 ps / 33,500 r.p.m.
■ Weight	221.1g (7.80 oz.)

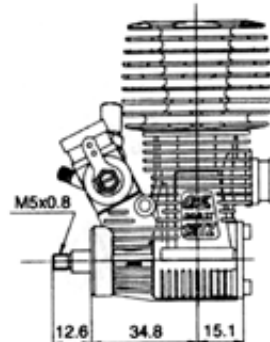
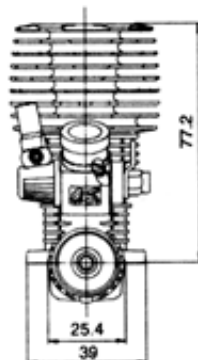
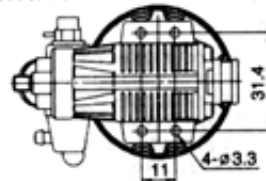

50