

Z41BTM56
ASSEMBLY INSTRUCTIONS

Every dream has a beginning and an end. This one just happened to start out in the O'Donnell family garage back in 1980. Young Steve O'Donnell wasn't satisfied with the mediocre products that the RC industry had to offer, so he set out to build the best engineered and manufactured products available. Lucky for us, his dream is far from over...

O'Donnell took his vast knowledge of nitro engine tuning and soon designed products that would complement his talents. First came his custom designed and machined aluminum cooling heads for the on-road racing scene. Finding another void in the industry, he also began producing custom tuned pipes to better utilize all of the power these nitro burning monsters could produce.

The efforts of O'Donnell did not go overlooked. Some of the major R/C manufacturers went to O'Donnell Manufacturing to have their trick aluminum parts machined. O'Donnell's meticulous standards and overwhelming knowledge of the products made it a natural fit. Over the past 28 years, O'Donnell Manufacturing has produced parts for such notable companies as Team Associated and Team Losi.

O'Donnell Manufacturing took another major step forward in 1988 when they introduced O'Donnell Racing Fuel...the name that made them famous with racers around the world. Once again, O'Donnell saw a need — for a high-quality fuel specifically blended for the demands of nitro burning car engines. From that point on, O'Donnell Racing Fuel became synonymous with winning. To this day, no other fuel has won as many national championships as O'Donnell Racing Fuel.

To complement the racing fuel, O'Donnell set out in 2000 to design a glow plug that would out-perform and out-last all the competitors. The result? Two U.S. patents and a World Championship. Not bad for someone who started out in his parents' garage. Today, O'Donnell glow plugs are the choice of champions worldwide.

In 2008, O'Donnell released their Z01-B 1/8 Off-Road Buggy to the RC racing world. Throughout its two year development period, prototypes of the new buggy racked up impressive results in competitions nationwide. Racers are amazed at the durability and reliability (not to mention outstanding fit & finish) of this rugged machine. It is simply the toughest 1/8 buggy on the market.

Now, after even further development, refinement, testing, as well as feedback from Z01-B owners and team drivers, we are proud to introduce the Z01B-SG Team Edition. The SG Team Edition features a wide variety of updates that make this the Ultimate Racing Buggy!

- *O'Donnell™ guarantees this kit to be free from defects in both material and workmanship at the date of purchase. O'Donnell will warranty this kit for 90 days after the purchase date. O'Donnell will repair or replace, at no charge, the incorrectly made part.*
- *Make sure you save the receipt or invoice you were given when you bought your model! It is your proof of purchase and we must see it before we can honor the warranty. Further, O'Donnell reserves the right to change or modify this warranty without notice.*
- *In that O'Donnell has no control over the final user assembly or material used for final user assembly, no liability shall be assumed nor accepted for any damage resulting from the use by the user of the final user-assembled product. By the act of using the user-assembled product, the user accepts all resulting liability.*

To return your Z01B-SG Team for repairs covered under warranty you should send your buggy to:

Hobby Services
3002 N. Apollo Drive Suite 1
Champaign, Illinois 61822
Attn: Service Department
Phone: (217) 398-0007 9:00 am-5:00 pm Central Time M-F
E-mail: hobbyservices@hobbico.com
www.hobbyservices.com

If the buyer is not prepared to accept the liability associated with the use of this product, the buyer is advised to return this kit immediately in new and unused condition to the place of purchase.

Use care and good sense at all times when operating this radio controlled buggy. Failure to use this vehicle in a safe, sensible manner can result in injury or damage to property. You and you alone must insure that the instructions are carefully followed and all safety precautions are obeyed.

- Do not operate the Z01B-SG Team near people. Spectators should be behind the driver or at a safe distance away from the vehicle.
- Water can cause the electronics to short out and can cause permanent damage.
- Always turn on the transmitter before turning on the receiver.
- Fully extend the transmitter antenna before operating your vehicle.
- Before turning on your radio system, check to make sure that no one else is running on the same frequency.
- The engine and exhaust produce quite a bit of noise. Do not run this vehicle when or where it can disturb others.
- The engine and exhaust can become very hot. Avoid touching any of these parts during use and until they have cooled down.
- Model engine fuel is poisonous. Make sure you read and follow all of the precautions on the fuel container. Keep fuel out of the reach of children.
- Model engine fuel is flammable and when ignited has a flame that is difficult to see. Avoid sparks, flames, smoking, or any other ignition source when fuel is near.
- The engine emits harmful fumes just like real vehicles. Do not operate this model indoors.
- Avoid running the buggy in cold weather. The plastic and metal parts can become brittle at low temperatures. In addition, grease and oil become thick, causing premature wear and poor performance.

- Read the instructions carefully before starting assembly.
- We recommend building the kit on a towel to help prevent small parts and screws from rolling off your work surface.
- Before turning on your radio system, check to make sure that no one else is running on the same frequency.
- Do not use an electric screwdriver/drill for assembling the kit. This could cause parts to strip out from overtightening.
- Use a quality threadlock where specified in the manual.
- Reamers for suspension arms are available at www.mcmaster.com, part numbers: 8803A324 (.164")
3002A21 (.123")



- Parts for step included in this parts bag.

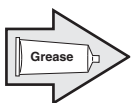

- Apply grease to part(s) indicated. **Note:** Always use black moly grease on areas indicated.

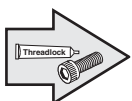

- Apply threadlock to screw(s) indicated. **IMPORTANT:** Clean oil or film from screws before applying threadlock.



Transmitter

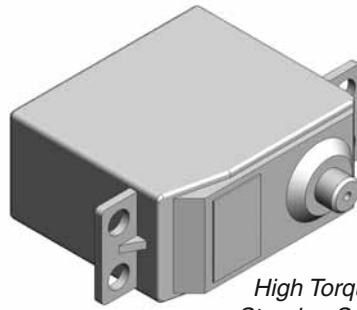

High Torque Steering Servo

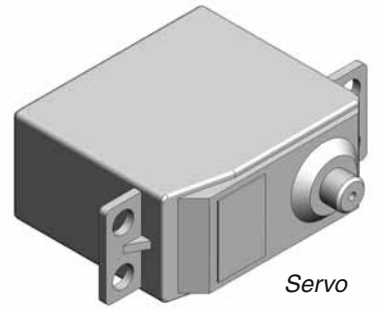

Servo



Receiver



5-Cell Receiver Hump Pack



Engine



Tires

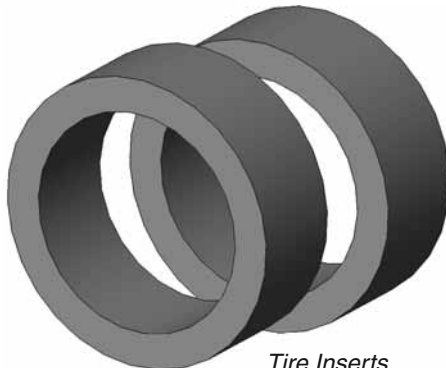

Tire Inserts

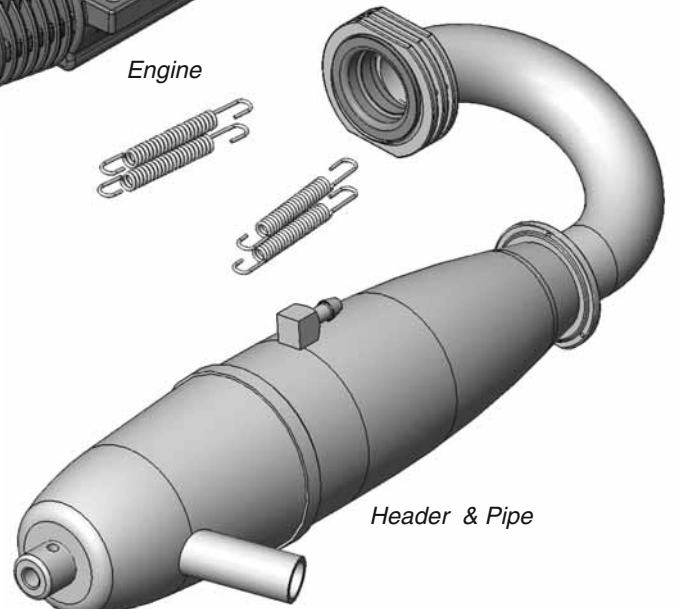

Header & Pipe



Threadlock



CA Tire Glue



Diff, Shock & Air Filter Oils



Glow Plug
(and spares)



Fuel
Bottle



1.5mm Hex
Wrench



2.0mm Hex
Wrench



2.5mm Hex
Wrench

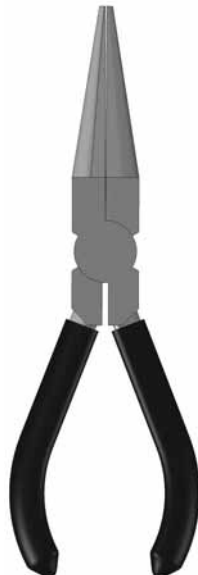

Needle-Nose
Pliers



Hobby
Knife



Glow Plug
Ignitor



.164", .123"
Reamers
(See page 3
for purchasing info.)



4-Way
Wrench



Slip-Joint
Pliers



Body
Scissors

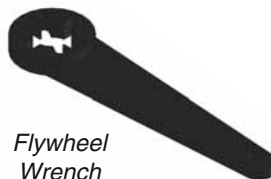

Flywheel
Wrench

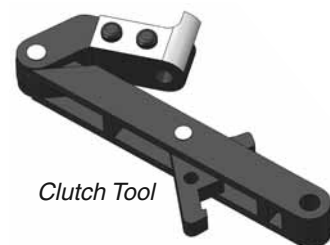

Clutch Tool

1

DIFF HOUSING

HARDWARE



(x3)

8x16mm Bearing



(x3)

Diff Outdrive O-Ring



(x3)

Sun Backing Washer

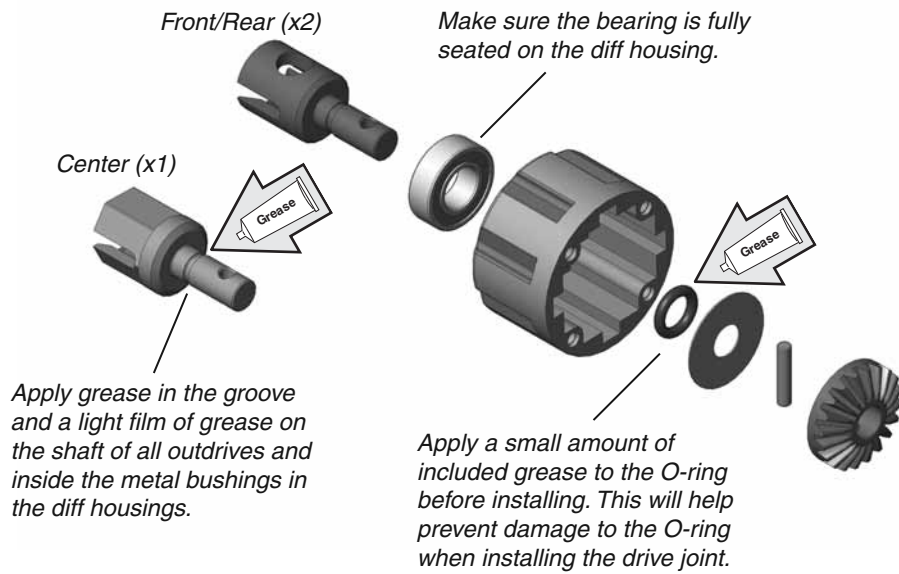

1

2

DIFF PLANETARY GEARS

HARDWARE



(x12)

Satellite Backing Washer

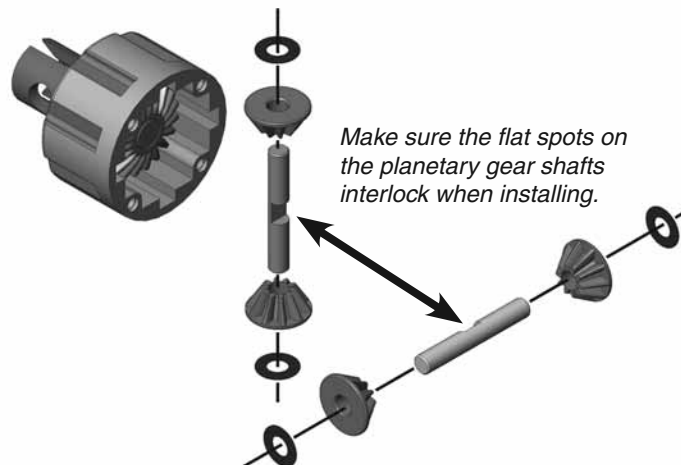

1

HARDWARE



(x3)
8x16mm Bearing



(x3)
Diff Outdrive O-Ring



(x3)
Sun Backing Washer

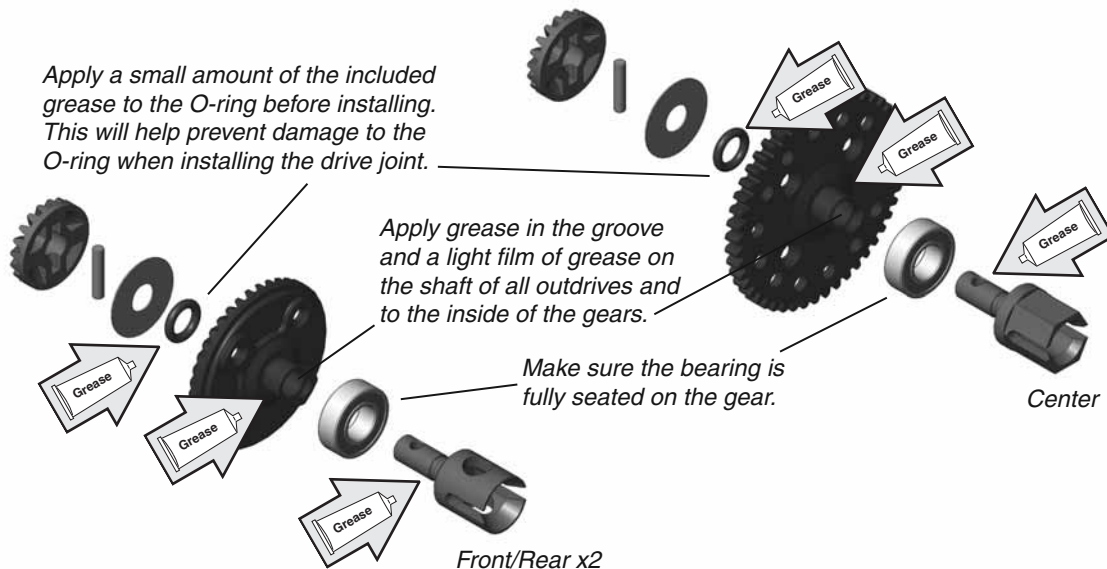

HARDWARE



(x12)
3x12mm FH Screw



Build the front, rear and center diffs.



Fill the diff until the planetary gear shafts are completely covered with diff oil. When using heavy oils, you need to allow the oil to settle and add oil if necessary. Do not overfill! **(Note: See set-up sheet for recommended diff oils.)**

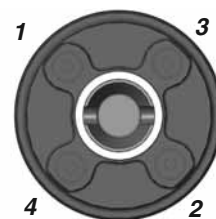

Finish tightening the diff gear screws in order. This will help make sure the gear is mounted flat on the diff housing and the housing is properly sealed.

5

CENTER DIFF MOUNTS

HARDWARE



(x2)

3x6mm FH
Screw



(x4)

4x12mm FH
Screw

IMPORTANT!
The grooves for the diff
bearings face inward.

Make sure the brake disc guides
are interlocked with the diff
mounts before installing.

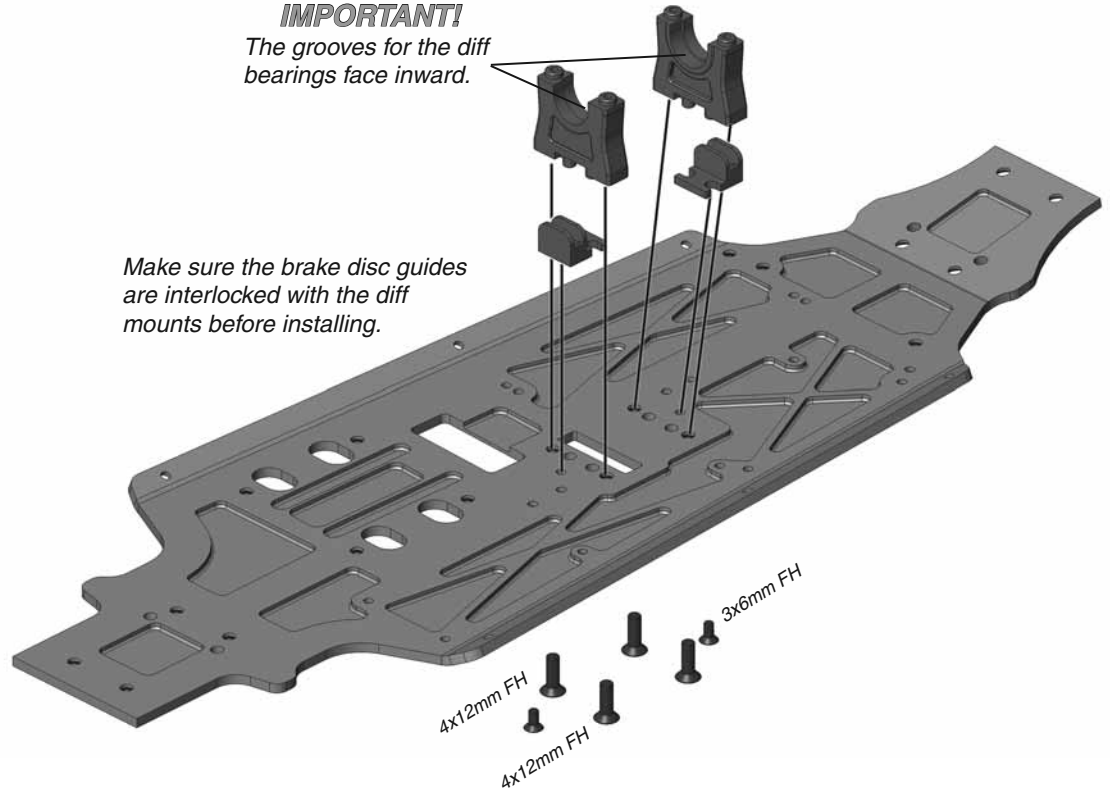

2

6

MOUNT THE CENTER DIFF

HARDWARE



(x4)

Brake Pad Bolt

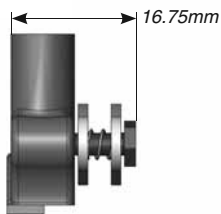

IMPORTANT!
Brake pad bolt adjustment
must be correct.

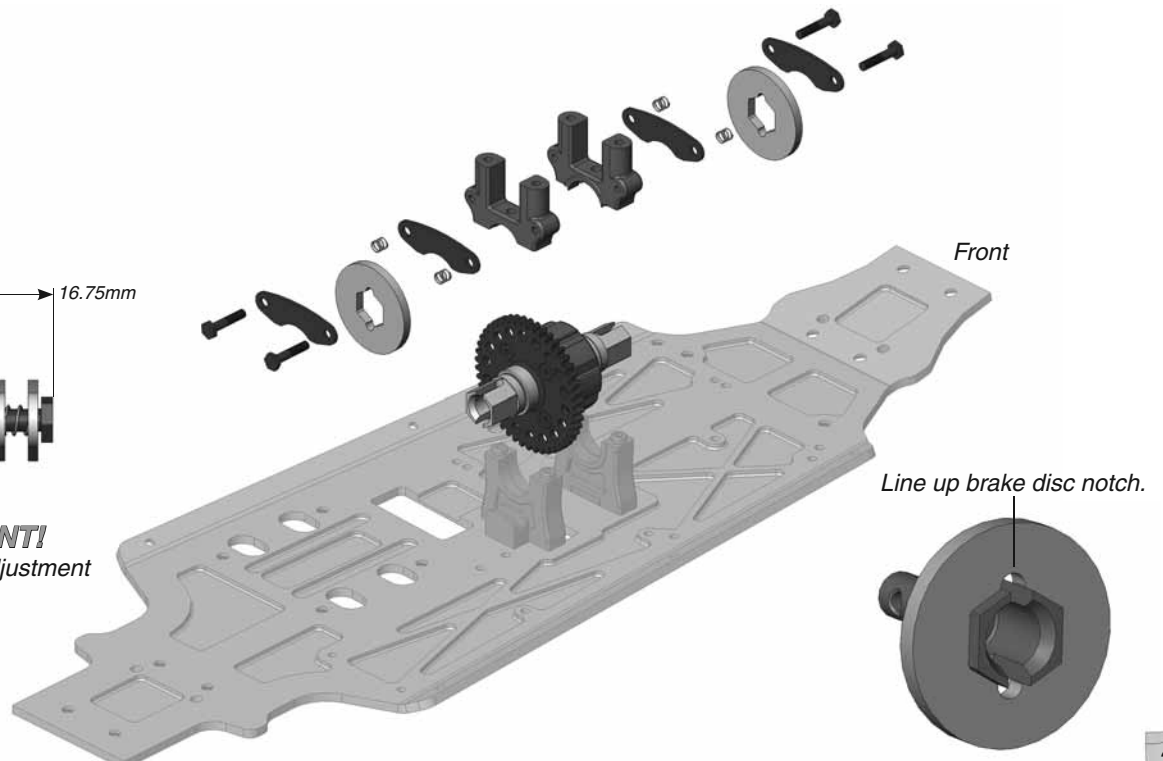

2

HARDWARE



(x4)
3x35mm BH
Screw



(x2)
5x8mm Flanged
Bearing



(x2)
3x4mm Set
Screw



(x2)
3x8mm BH
Screw

Install the **front** brake actuator rod into the front brake actuator **before** installing the upper plate. Secure with 3mm set screw.

Install the **rear** brake actuator rod into the rear brake actuator **after** installing the upper plate. Secure with 3mm set screw.



IMPORTANT!

Mount the fuel filter mount to the center upper brace before installing the center upper brace to the center diff mounts.

The angled side of the brake actuator faces the brake plate.

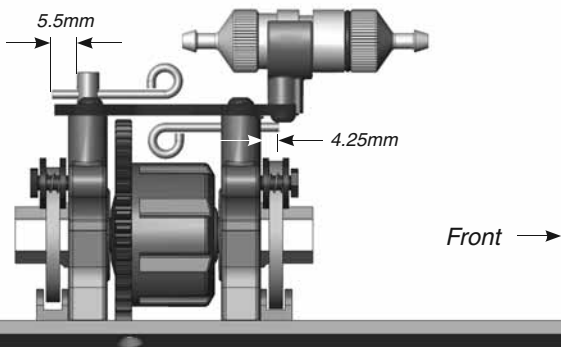
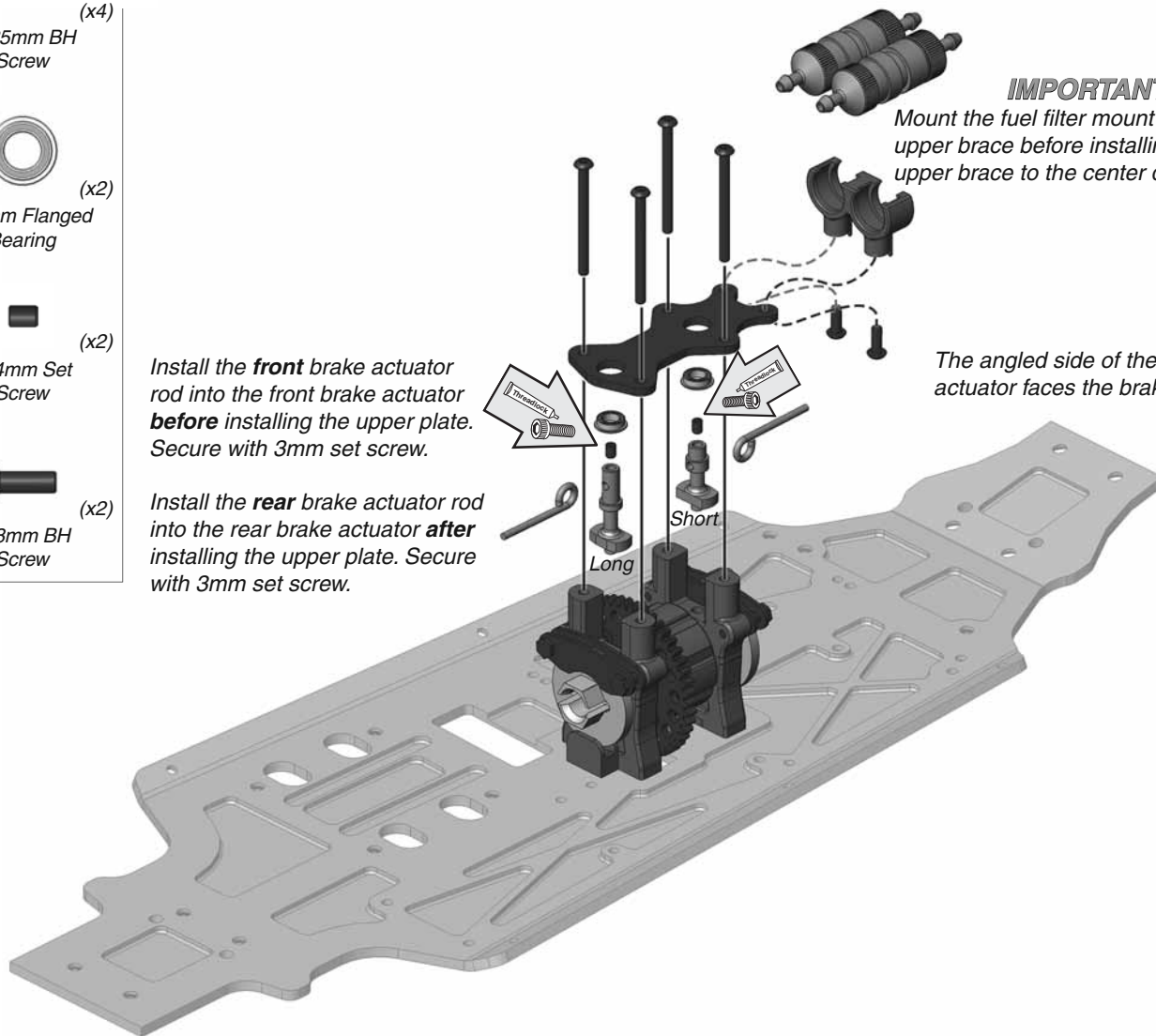

HARDWARE

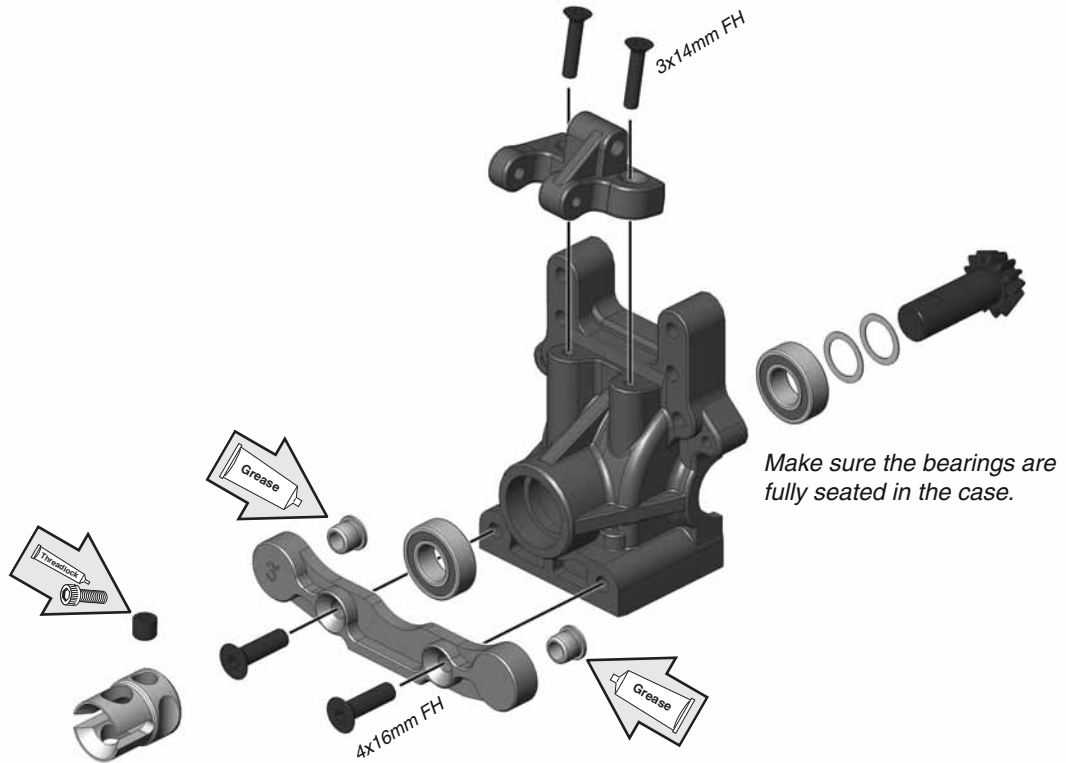
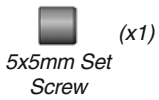
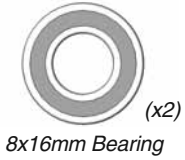
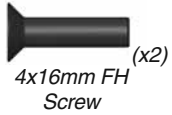

HARDWARE

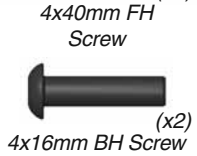

Use the included shims to space gears properly in the diff case. Adjust the gear mesh for smooth rotation without excessive play. The number of shims needed, and the side on which they must be placed, may vary.

IMPORTANT!

The suspension arms must move freely on the hinge pins. Use a .164" reamer for the inner suspension arm holes. See Page 3 for reamer ordering information.

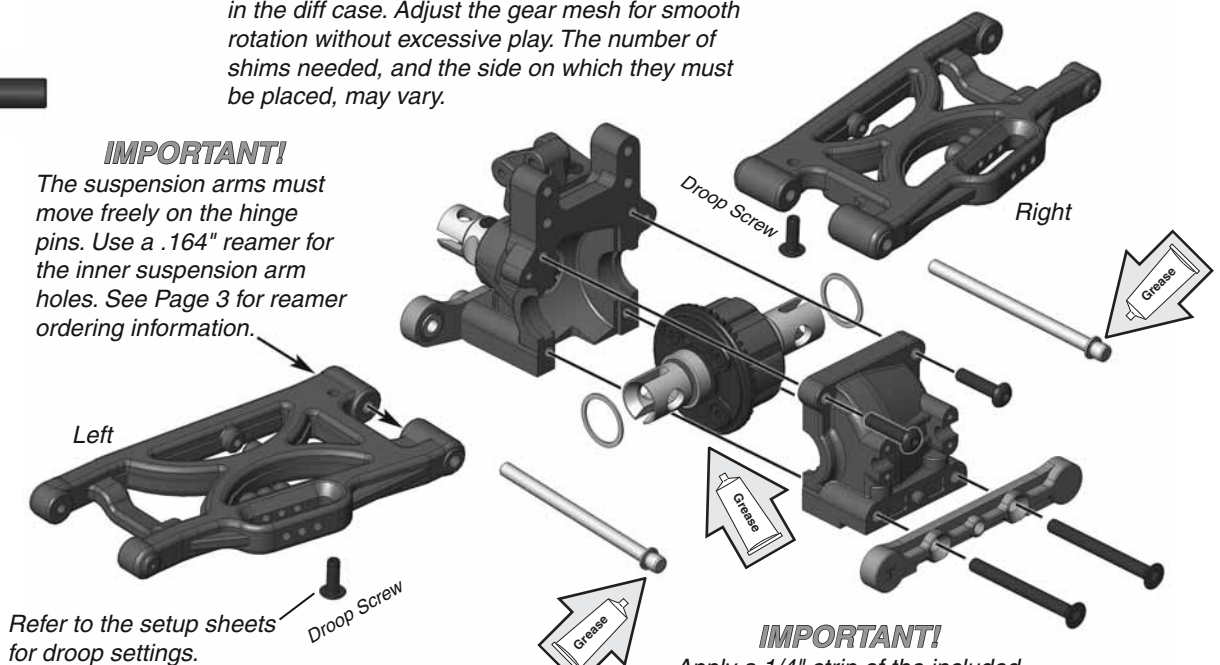

IMPORTANT!

Apply a 1/4" strip of the included grease to three locations on the ring gear.

10

REAR SHOCK TOWER

HARDWARE

 (x2)
4x14mm FH Screw

 (x2)
3x12mm FH Screw

 (x2)
3x14mm BH Screw

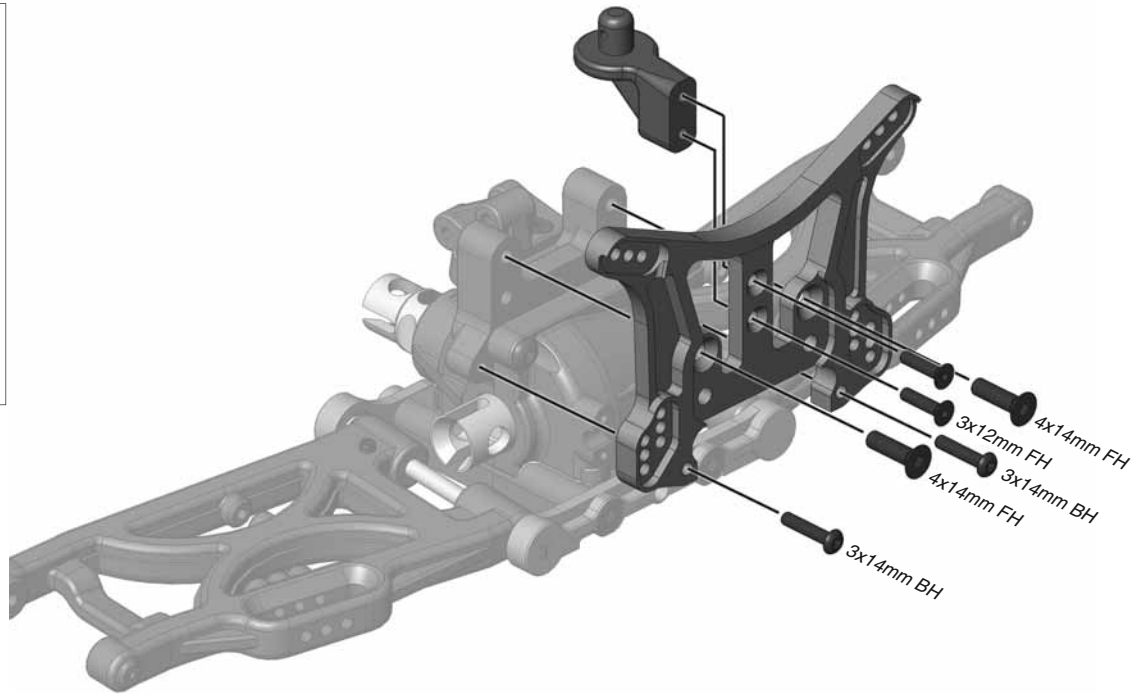

3

11

REAR OUTDRIVES

HARDWARE

 (x2)
Wheel Hub Pin

 (x4)
8x16mm Bearing

 (x2)
4x4mm Set Screw

 (x2)
5x5mm Set Screw

 (x2)
Shim



Use threadlock sparingly to prevent threadlock from seeping into critical areas. If this is not done cautiously it could cause the CVA to bind.

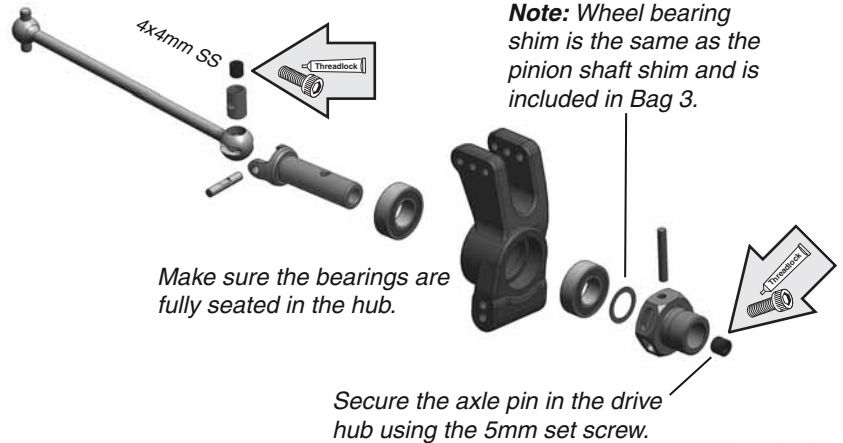

3

12

REAR UPPER LINK

HARDWARE



(x2)

3x25mm BH Screw



(x2)

3x6mm BH Screw

(x2)

Outer Lower Rear Hinge Pin



(x2)

3x18mm SH Screw



(x4)

3mm Lock Nut

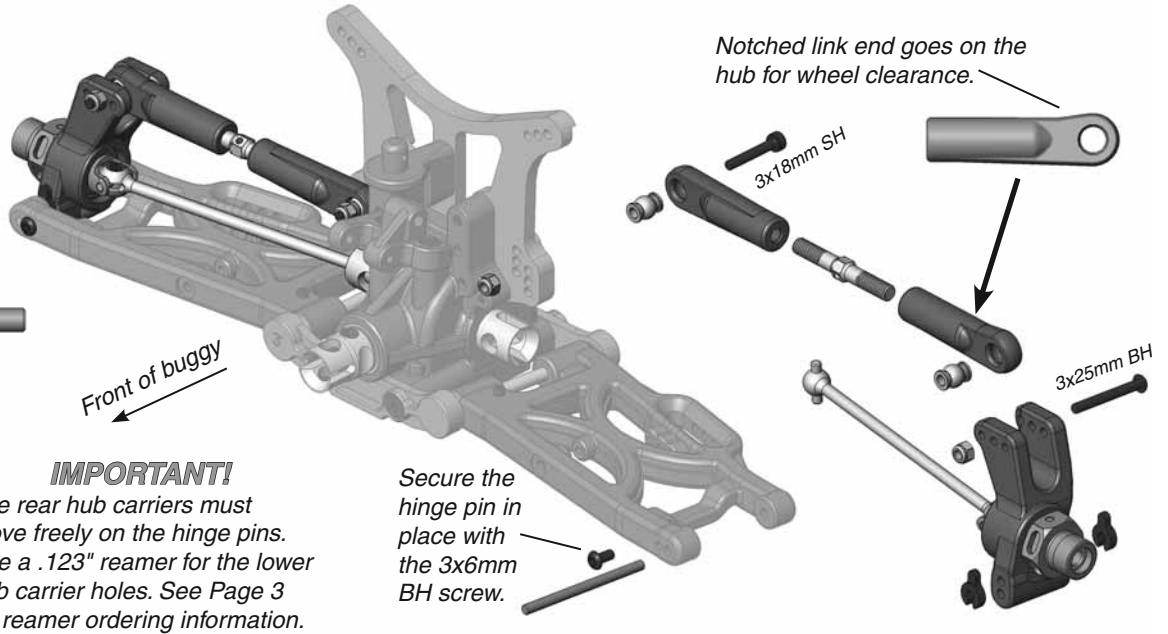

IMPORTANT!
The rear hub carriers must move freely on the hinge pins. Use a .123" reamer for the lower hub carrier holes. See Page 3 for reamer ordering information.

Secure the hinge pin in place with the 3x6mm BH screw.

If you find that your ball ends are binding on the balls, use a pair of pliers and firmly squeeze the ball end while it is on the ball. **Note: Do not over-squeeze the ball end. This can cause the ball ends to deform and pop off during running. We do not recommend using needle nose pliers.**



3

13

WING MOUNT

HARDWARE



(x2)

3x10mm BH Screw



(x4)

3x25mm FH Screw



(x4)

3mm Countersunk Washer



(x2)

4x20mm FH Screw

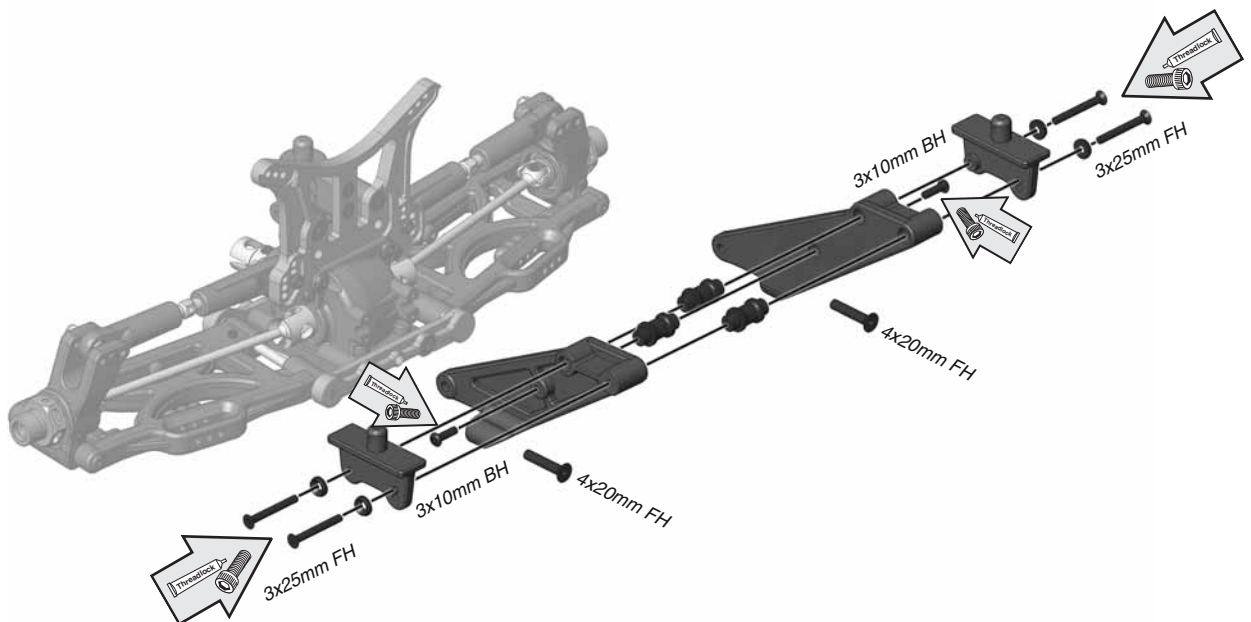

4

HARDWARE



IMPORTANT!

There are three sizes of swaybars and swaybar bushings. Be sure to use the correct bushing with its corresponding swaybar.

Rear Swaybar	Bushing
Medium .093" OD	Medium
Firm .106" OD	Large
X-Firm .118" OD	X-Large

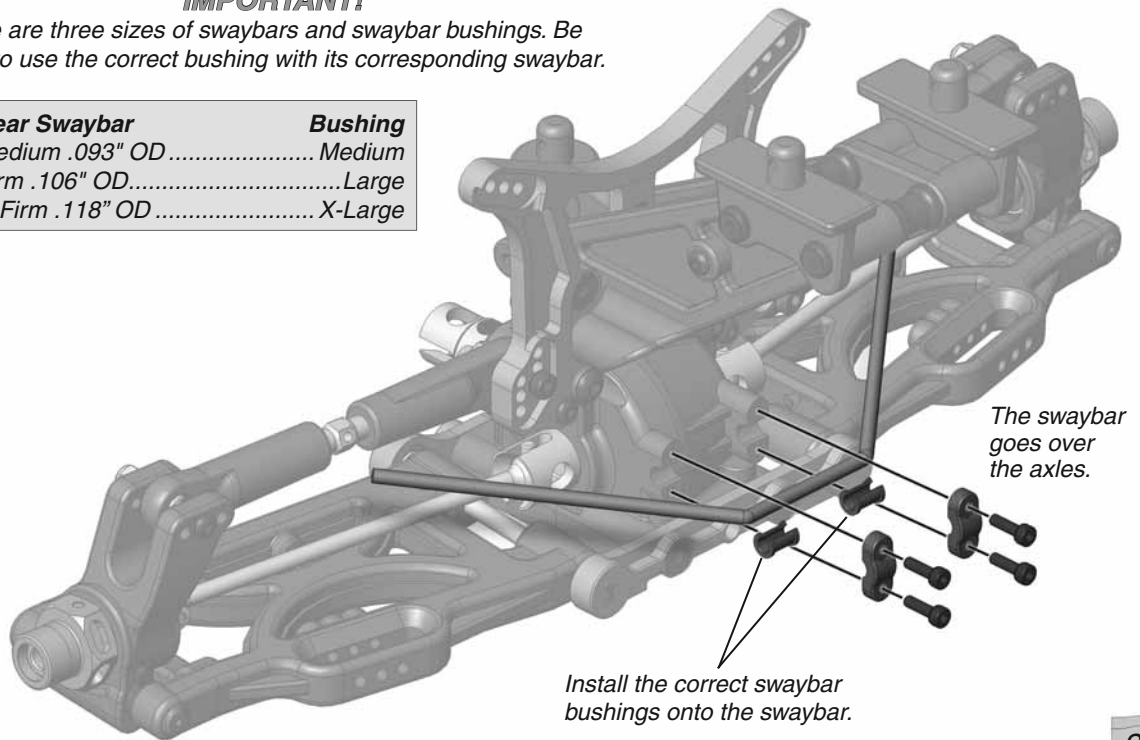

HARDWARE

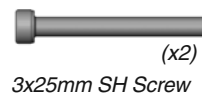

IMPORTANT!

Before connecting the links, make sure the installed sway bar moves freely, without resistance.

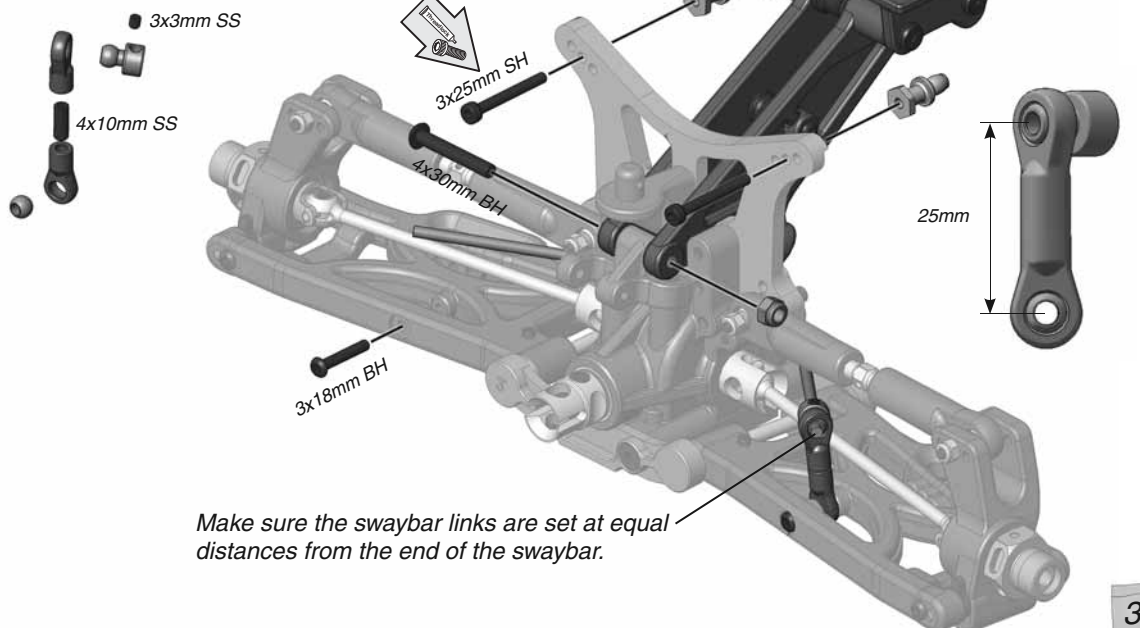

HARDWARE

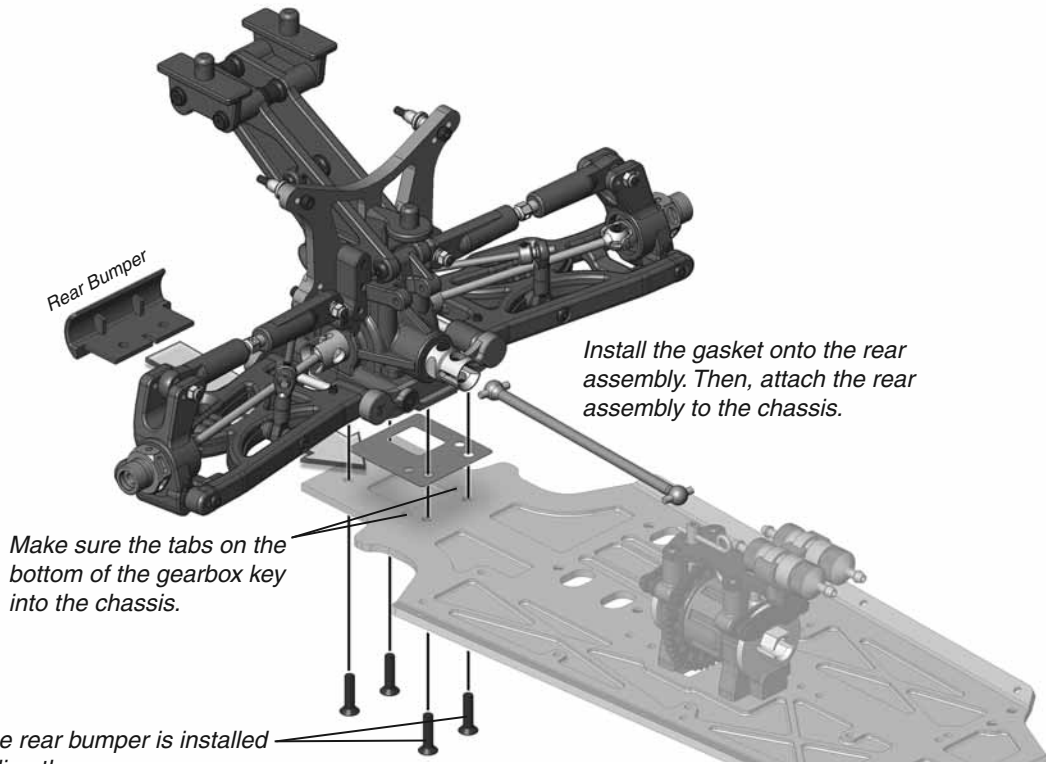
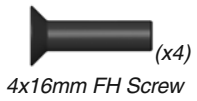

3

HARDWARE

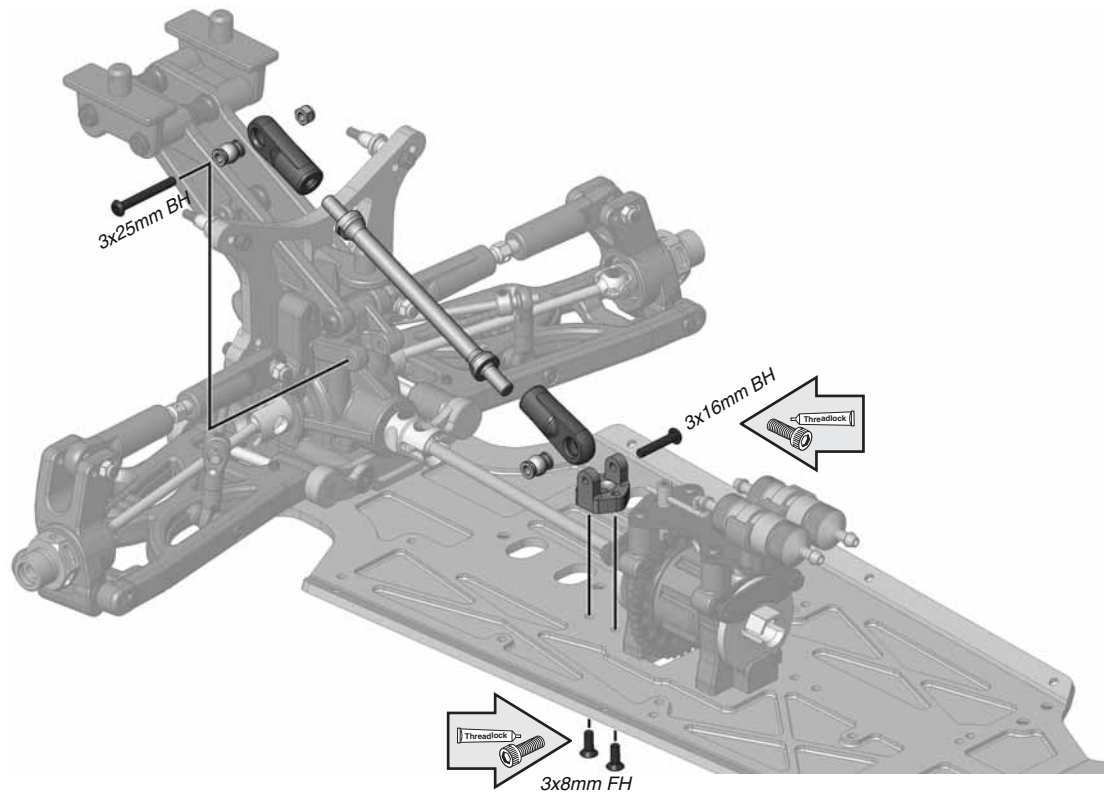

3

HARDWARE



(x2)

Pinion Shaft Shim



(x2)

8x16mm Bearing



(x2)

4x16mm FH Screw



(x1)

5x5mm Set Screw

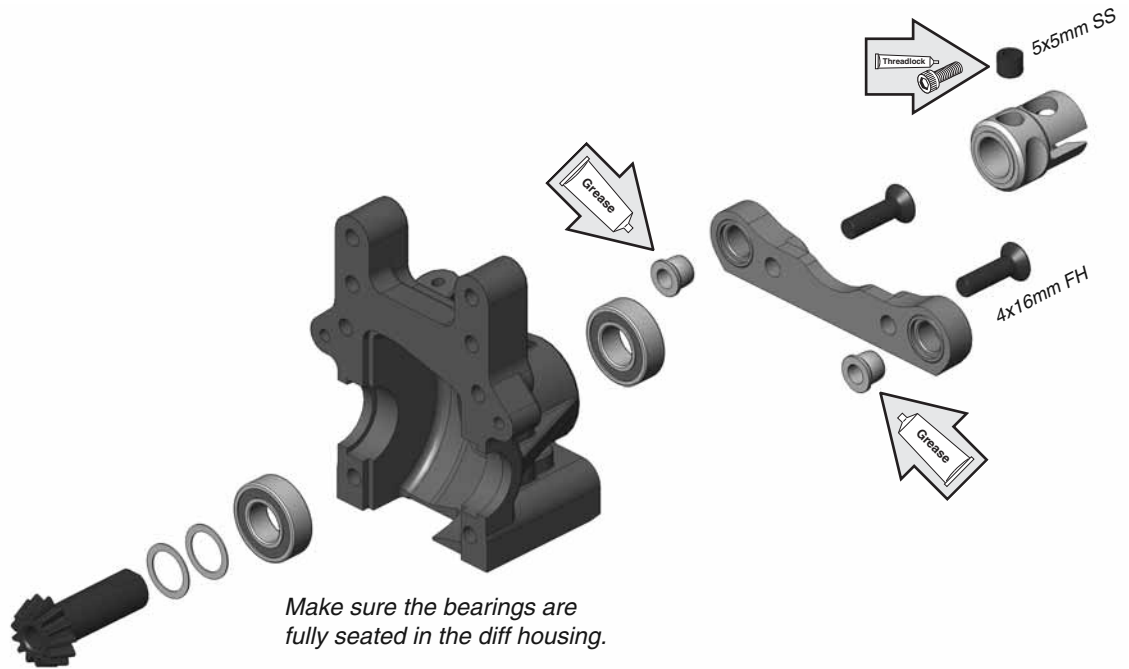

Make sure the bearings are fully seated in the diff housing.

HARDWARE



(x2)

4x40mm FH Screw



(x2)

4x16mm BH Screw



(x2)

Diff Shim (Gold)



(x2)

Diff Shim (Sliver)



(x2)

Droop Screw

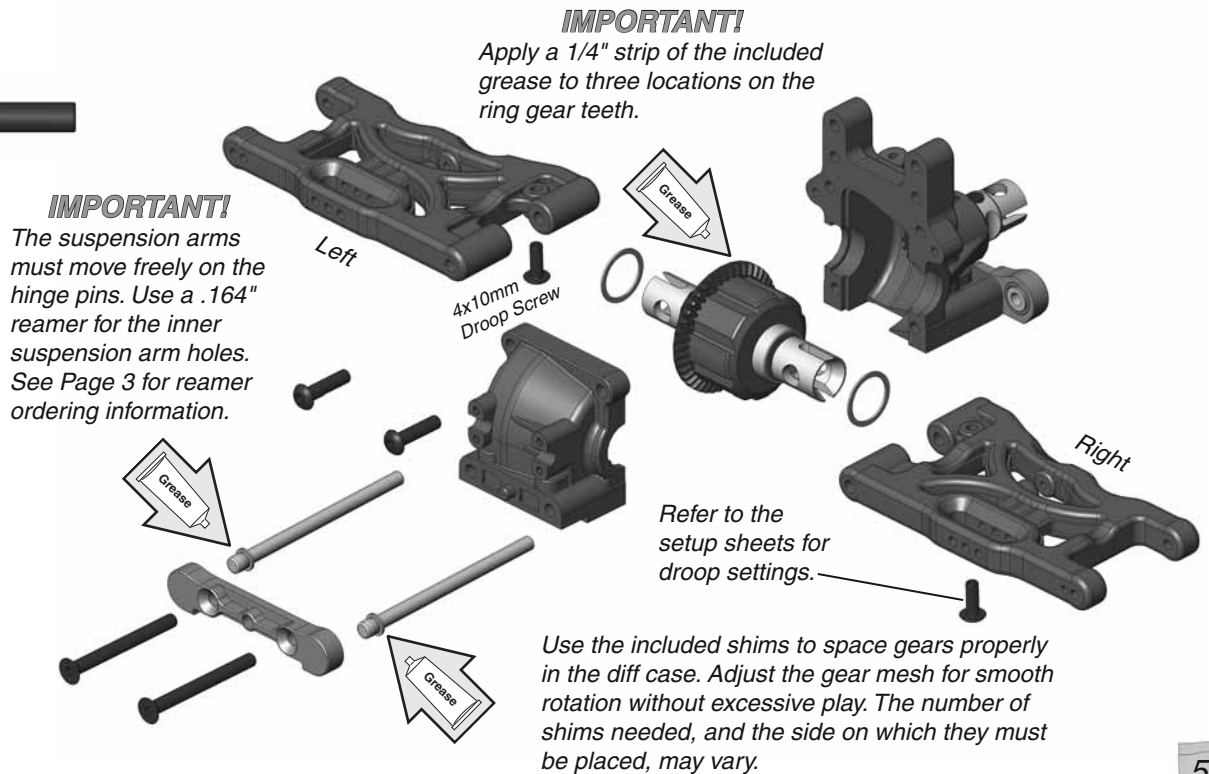

IMPORTANT!

Apply a 1/4" strip of the included grease to three locations on the ring gear teeth.

IMPORTANT!

The suspension arms must move freely on the hinge pins. Use a .164" reamer for the inner suspension arm holes. See Page 3 for reamer ordering information.

Refer to the setup sheets for droop settings.

Use the included shims to space gears properly in the diff case. Adjust the gear mesh for smooth rotation without excessive play. The number of shims needed, and the side on which they must be placed, may vary.

HARDWARE



(x4)

3mm Lock Nut



(x2)

3x6mm BH Screw



(x2)

3x18mm SH Screw



(x2)

3x20mm BH Screw



(x4)

Standard Rod End Ball



(x2)

Outer Lower Front Hinge Pin

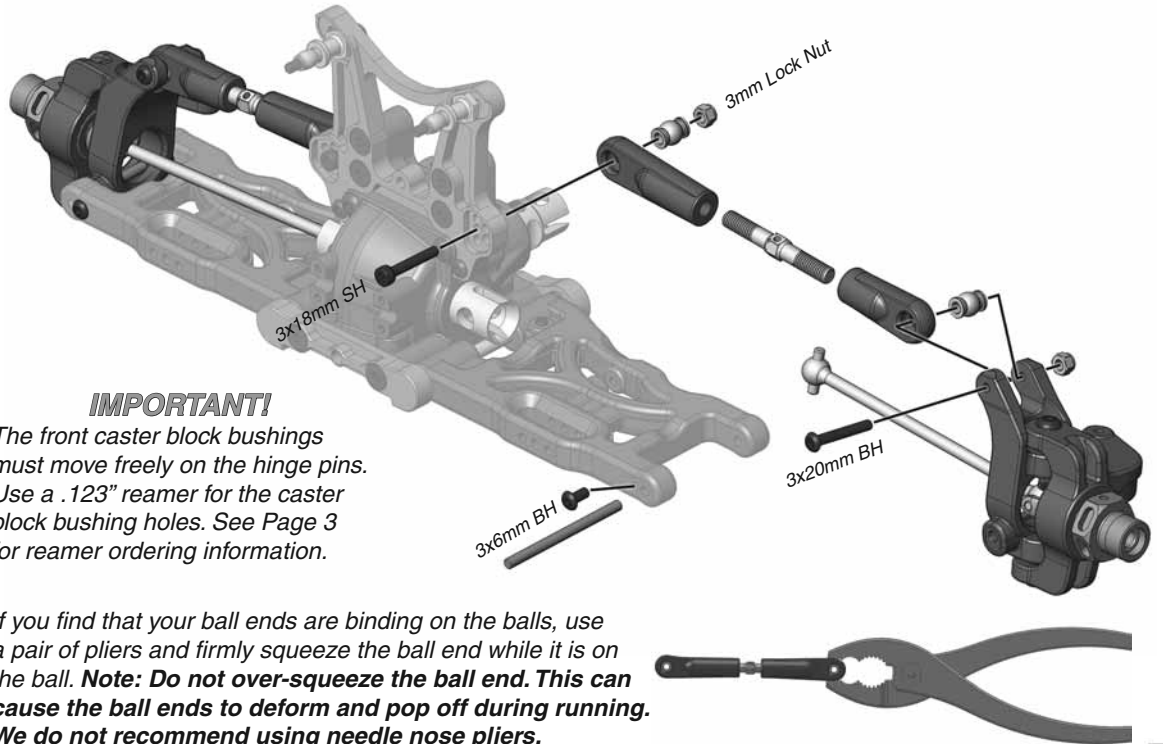

IMPORTANT!

The front caster block bushings must move freely on the hinge pins. Use a .123" reamer for the caster block bushing holes. See Page 3 for reamer ordering information.

If you find that your ball ends are binding on the balls, use a pair of pliers and firmly squeeze the ball end while it is on the ball. **Note: Do not over-squeeze the ball end. This can cause the ball ends to deform and pop off during running. We do not recommend using needle nose pliers.**

HARDWARE



(x1)

3mm Lock Nut



(x1)

3x16mm FH Screw



(x2)

6x10mm Bearing







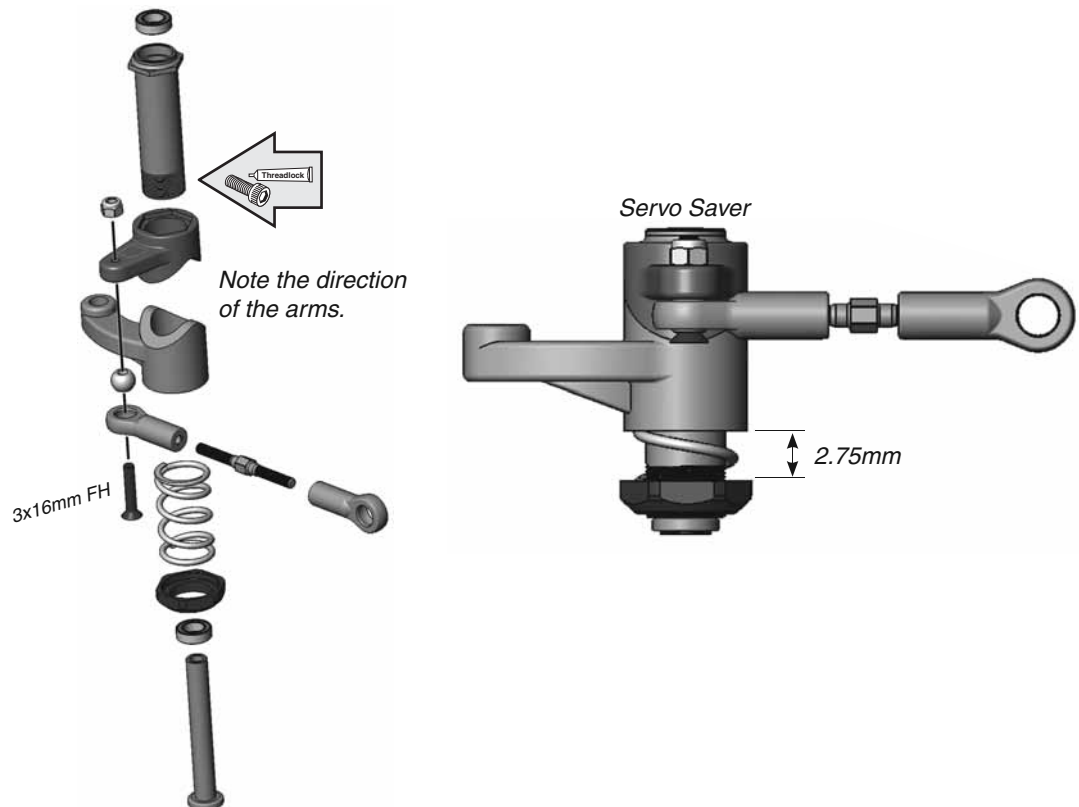

(x1)

Shock End Ball



HARDWARE

-  (x2)
3mm Lock Nut
-  (x2)
3x18mm FH Screw
-  (x4)
6x10mm Bearing
-  (x4)
Standard Rod End Ball
-  (x2)
4x8mm FH Screw
-  (x2)
3x16mm BH Screw

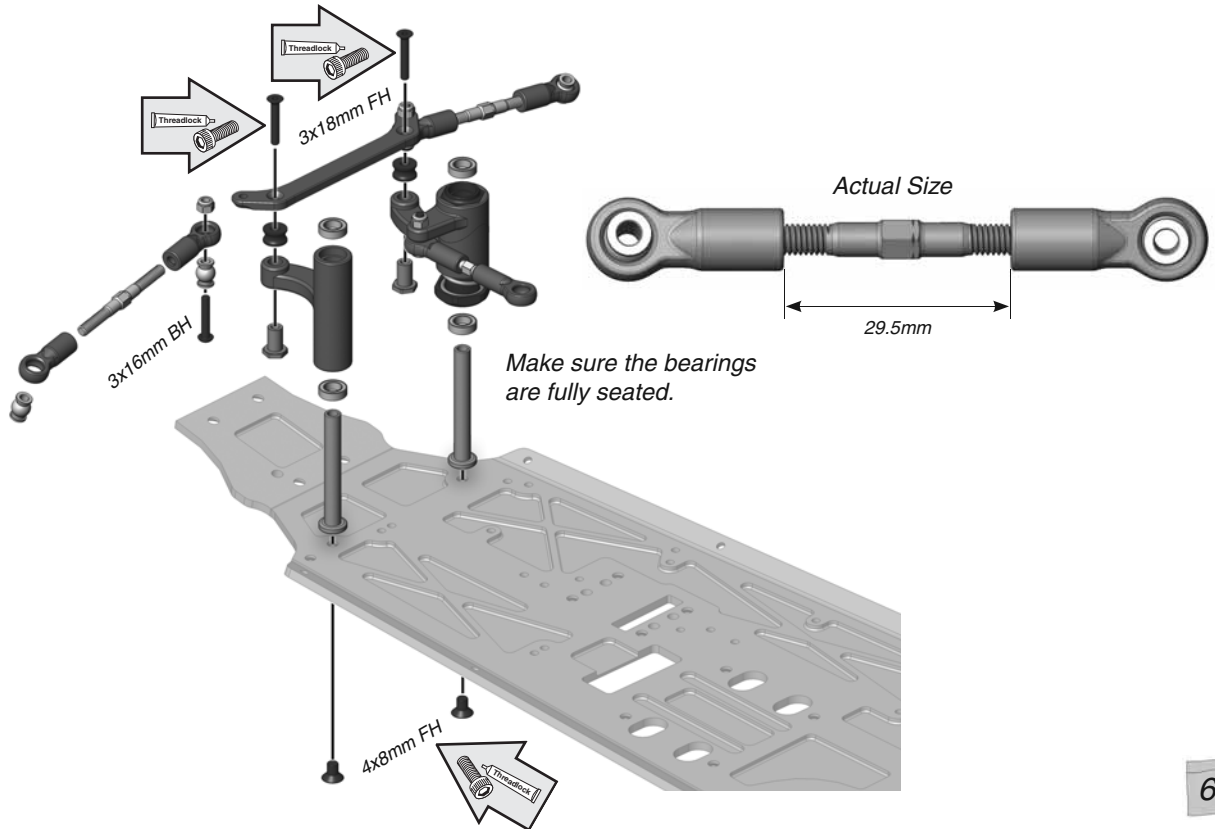

HARDWARE

-  (x4)
2.5x8mm SH Screw

IMPORTANT!



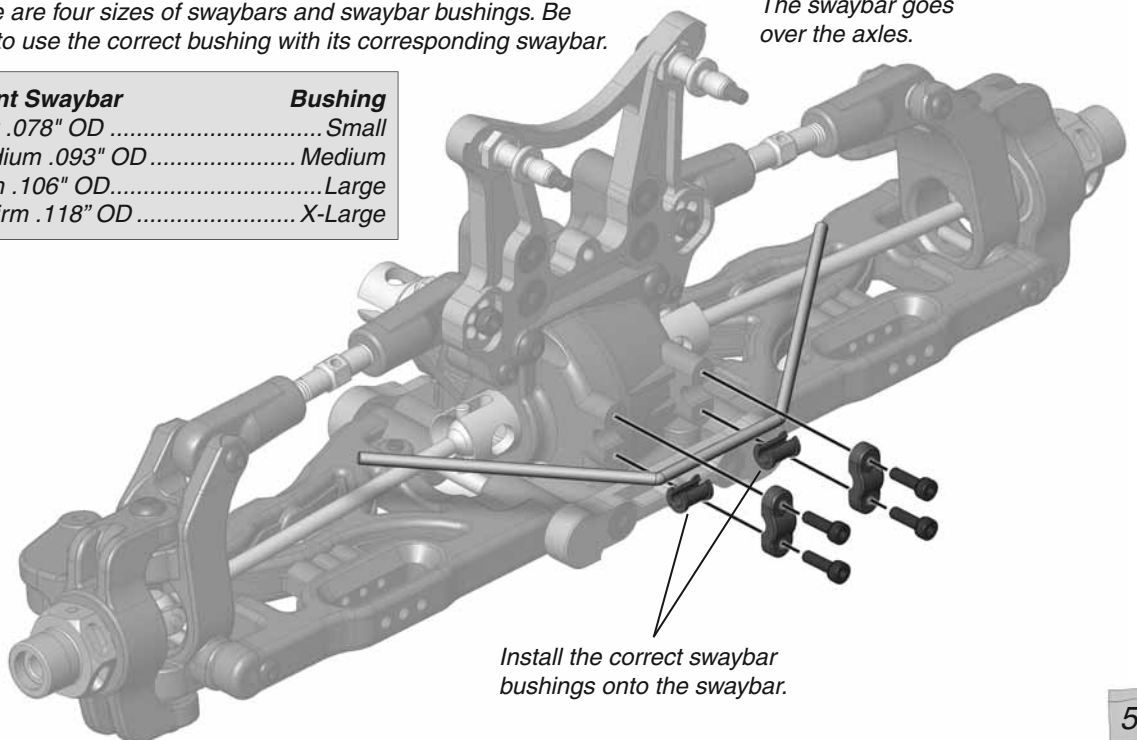

There are four sizes of swaybars and swaybar bushings. Be sure to use the correct bushing with its corresponding swaybar.

Front Swaybar	Bushing
Soft .078" OD	Small
Medium .093" OD	Medium
Firm .106" OD.....	Large
X-Firm .118" OD	X-Large

The swaybar goes over the axles.



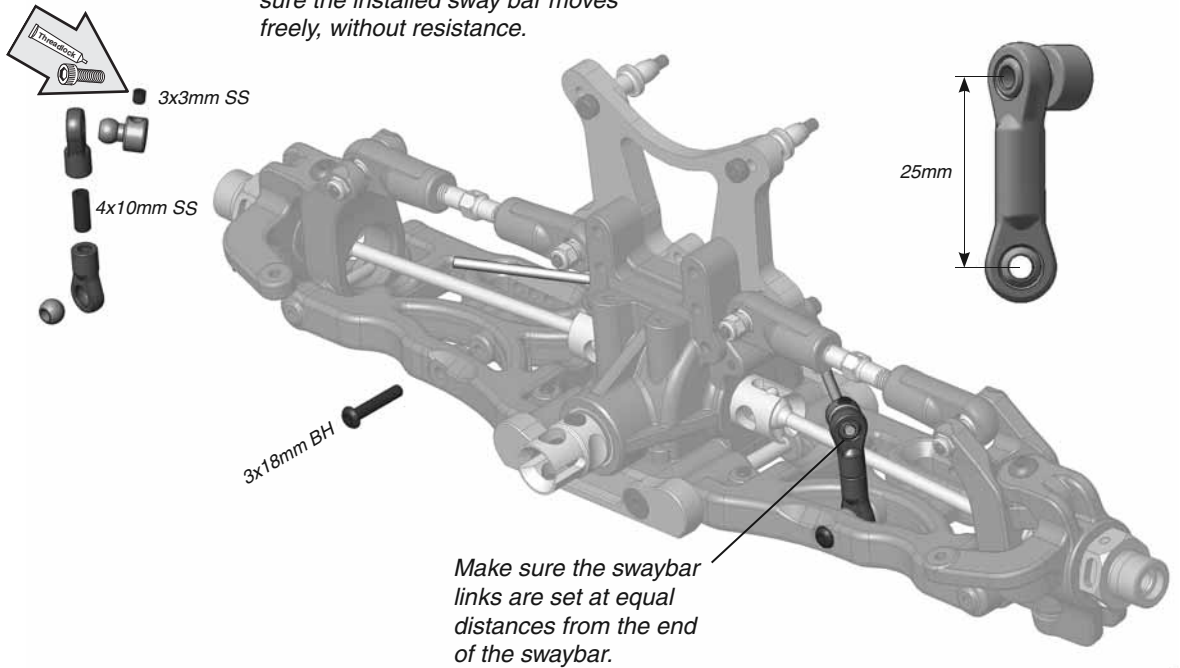

HARDWARE

-  (x2)
4x10mm Set Screw
-  (x2)
3x3mm Set Screw
-  (x2)
Sway Bar Ball
-  (x2)
3x18mm BH Screw



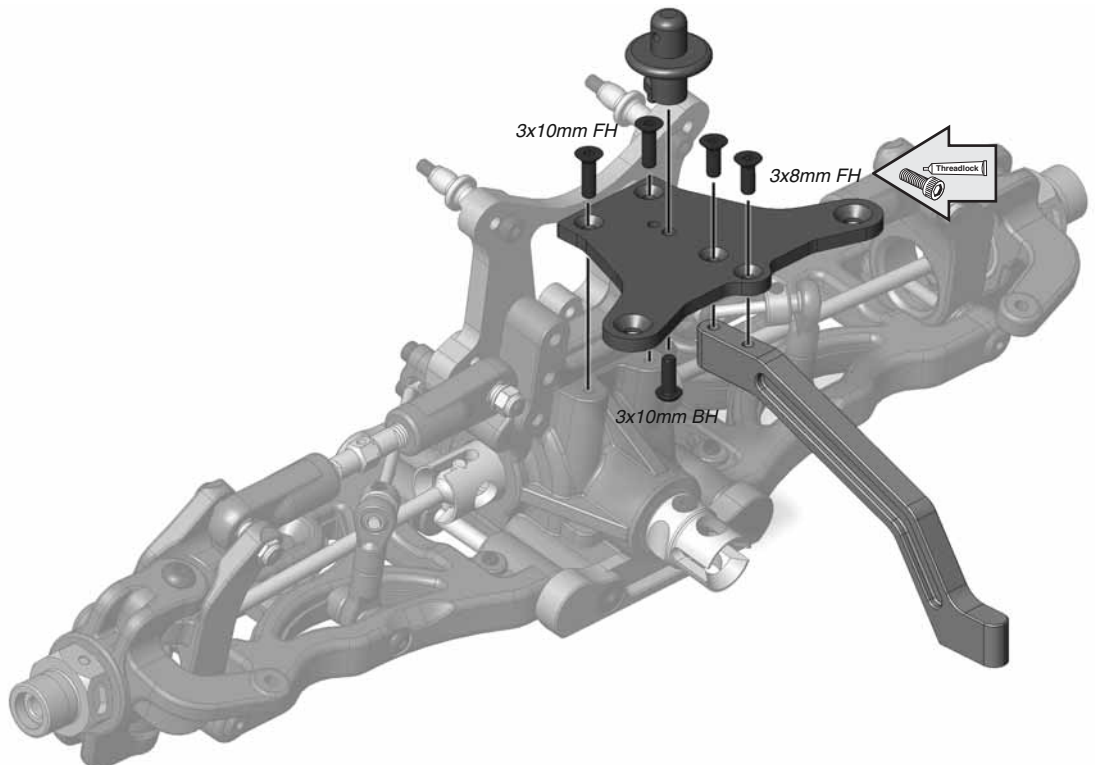

HARDWARE

-  (x2)
3x8mm FH Screw
-  (x2)
3x10mm FH Screw
-  (x1)
3x10mm BH Screw



HARDWARE

-  (x4)
4x16mm FH Screw
-  (x2)
3x8mm FH Screw

Make sure the tabs on the bottom of the gearbox key into the chassis.

Position the gasket between the gearbox and chassis.

Make sure the dogbone is placed under the steering rack bar.

Install a 1.5mm dogbone spacer inside the center drive cup.

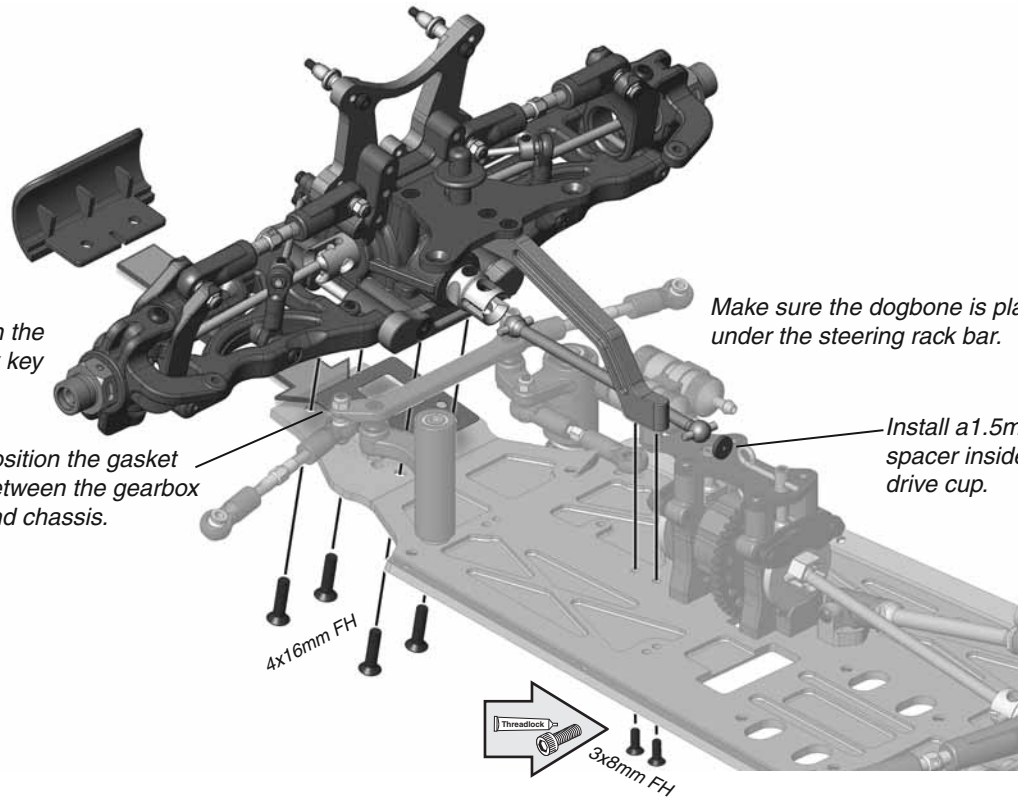

HARDWARE

-  (x2)
3x18mm BH Screw
-  (x2)
3mm Lock Nut
-  (x2)
4x8mm FH Screw
-  (x8)
3mm Washer

3x18mm BH

4x8mm FH

Make sure the steering link is mounted on **top** of the knuckle arm.

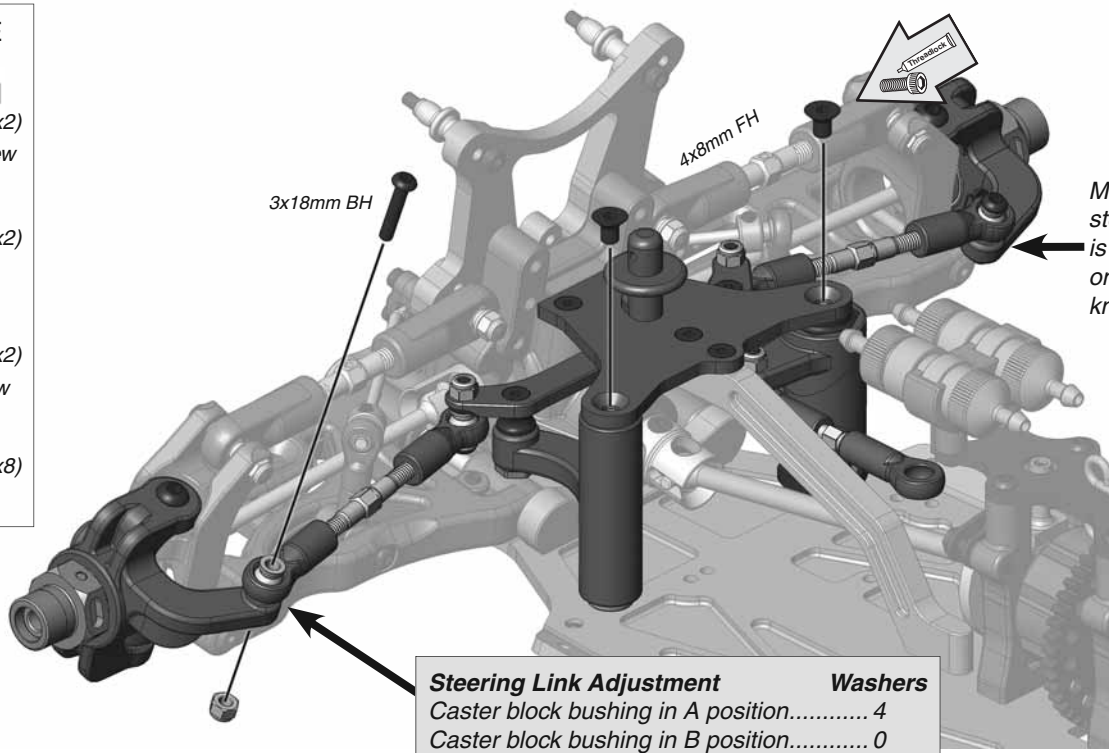

Steering Link Adjustment	Washers
Caster block bushing in A position.....	4
Caster block bushing in B position.....	0

HARDWARE



Throttle Servo	Spacer
Airtronics®/Sanwa.....	4mm*
Futaba®/DuraTrax®.....	4mm*
Hitec®/Hobbico®.....	2mm*
KO Propo.....	3mm*
JP Propo.....	2mm*

* Due to different types of servos, spacer size may vary.

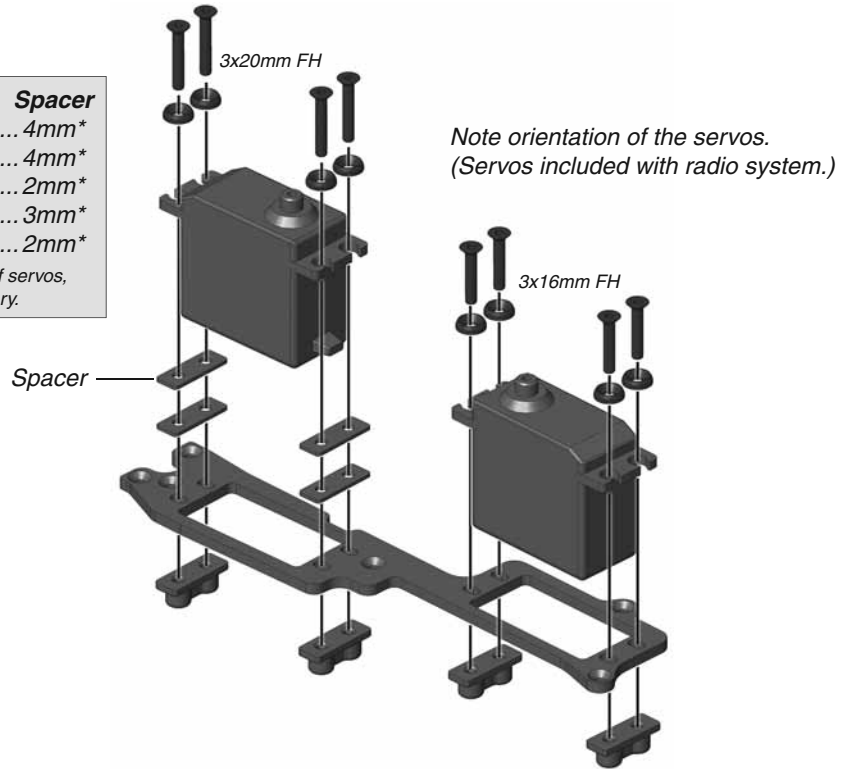

HARDWARE

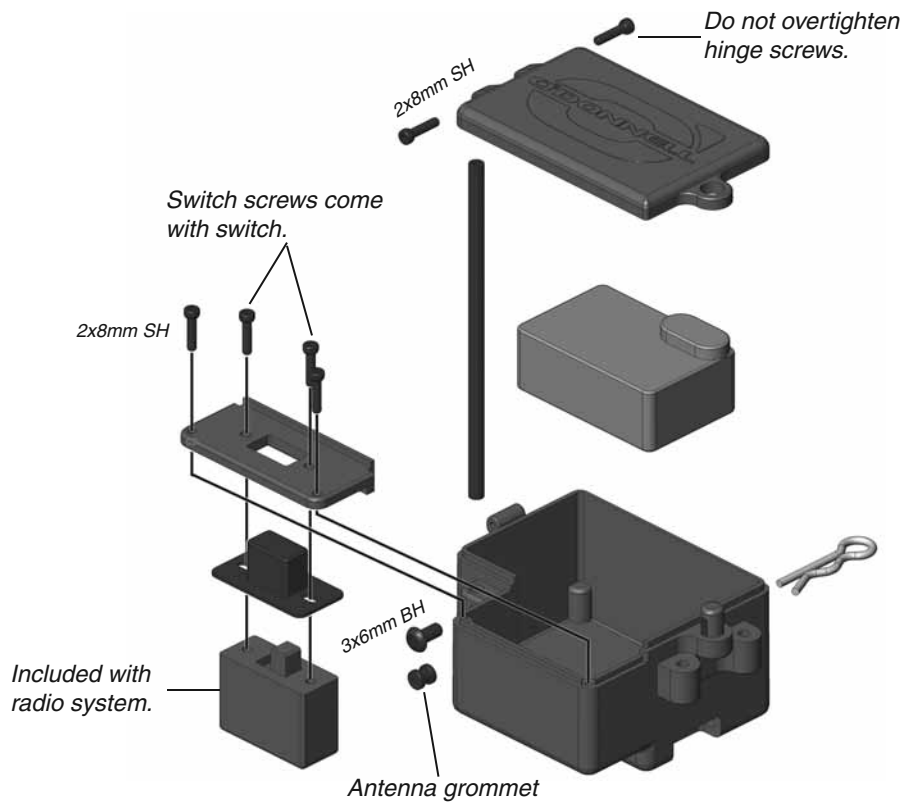
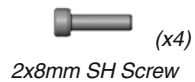

HARDWARE

 (x4)
3x8mm FH Screw

 (x2)
3x10mm FH Screw

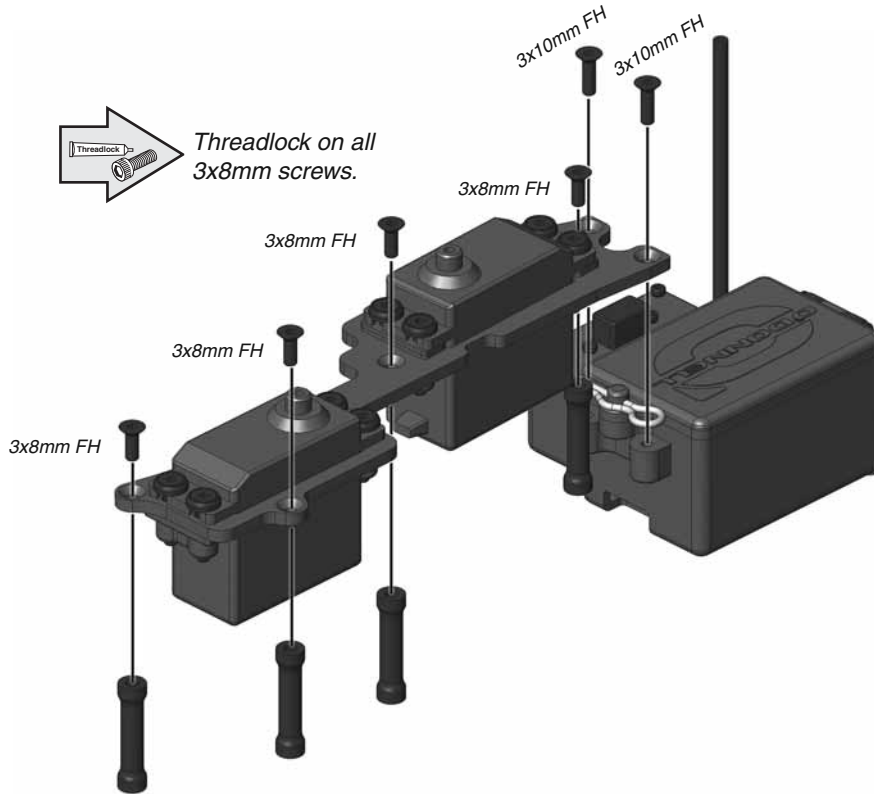

HARDWARE

 (x2)
2x8mm SH Screw

 (x1)
2.5x10mm FH Screw

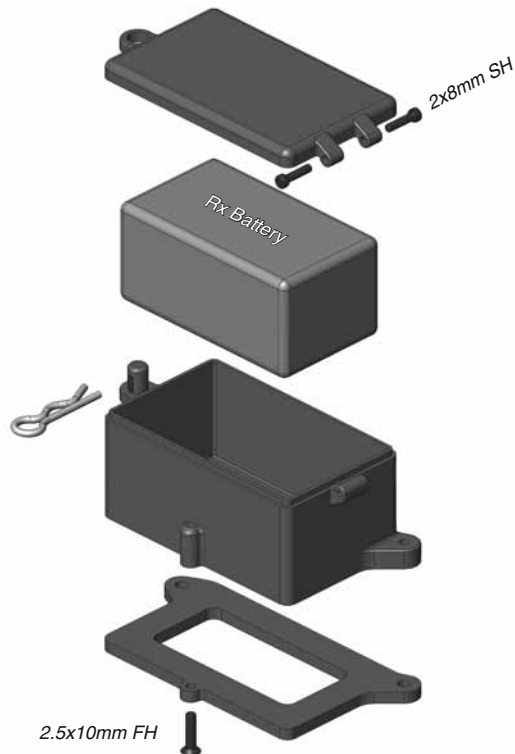

34

BATTERY BOX SPACERS

HARDWARE



(x2)

3mm Lock Nut



(x2)

3x20mm FH Screw

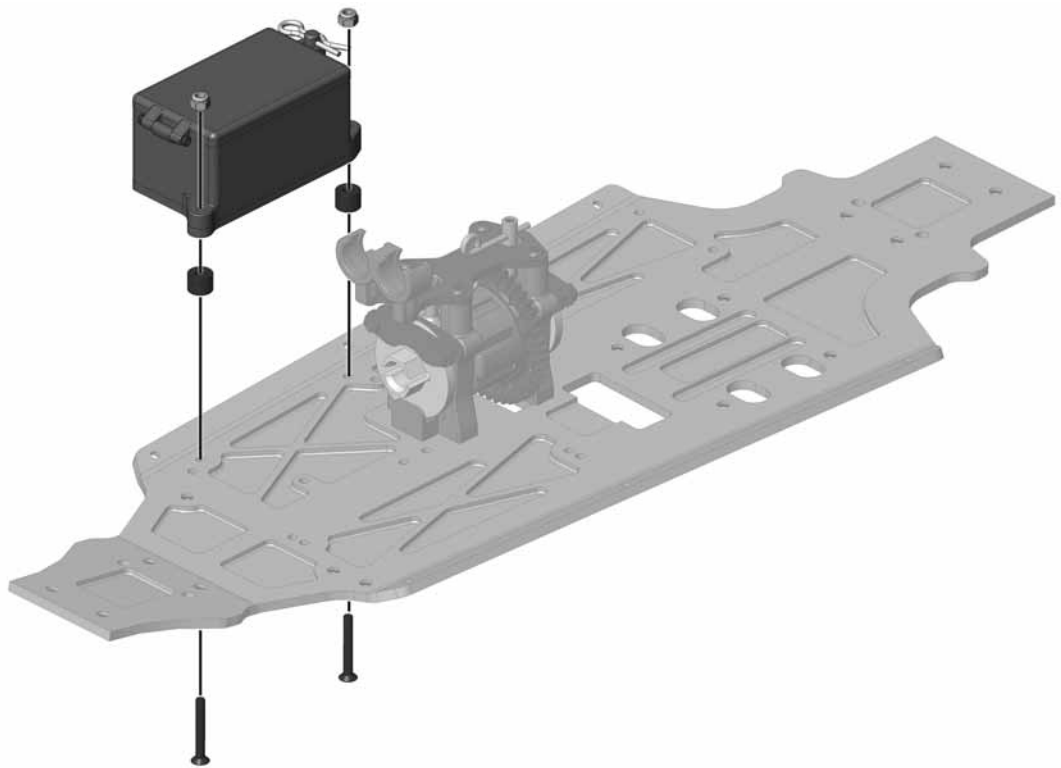

8

35

SERVO TRAY

HARDWARE



(x4)

3x8mm FH Screw







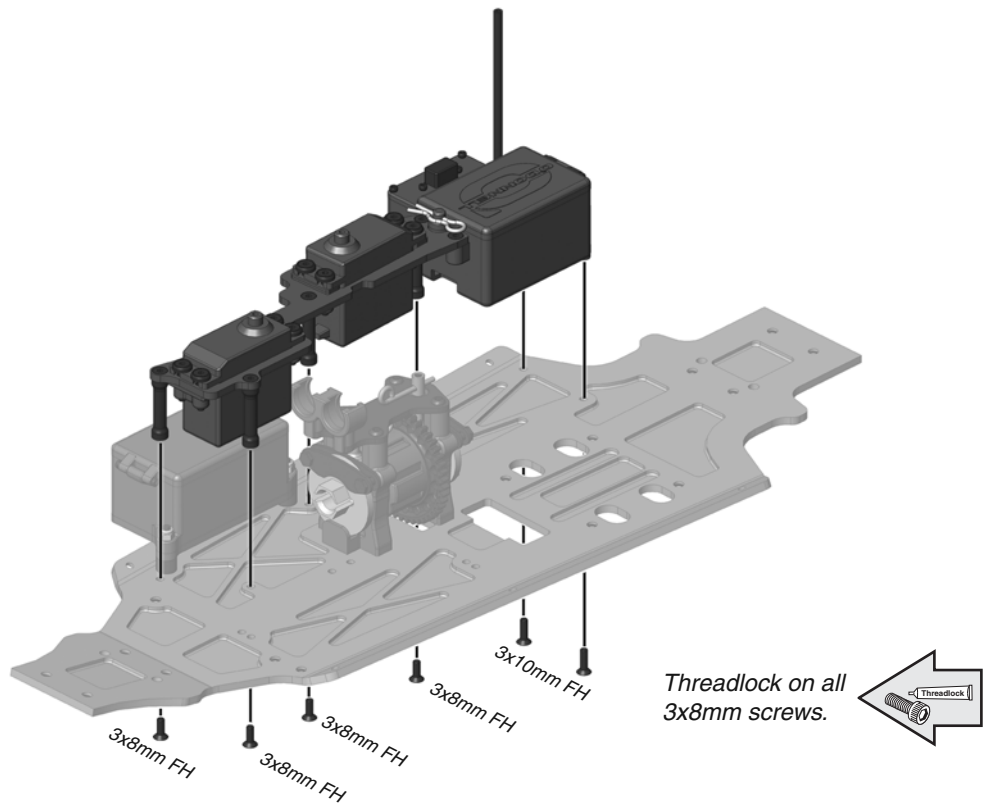



(x2)

3x10mm FH Screw



8

HARDWARE

-  (x1)
3x20mm BH Screw
-  (x1)
Standard Rod End Ball
-  (x1)
3mm Lock Nut
-  (x1)
3x16mm BH Screw
-  (x1)
3x10mm BH Screw
-  (x6)
3x3mm Set Screw
-  (x3)
3mm Washer
-  (x2)
Fuel Tubing

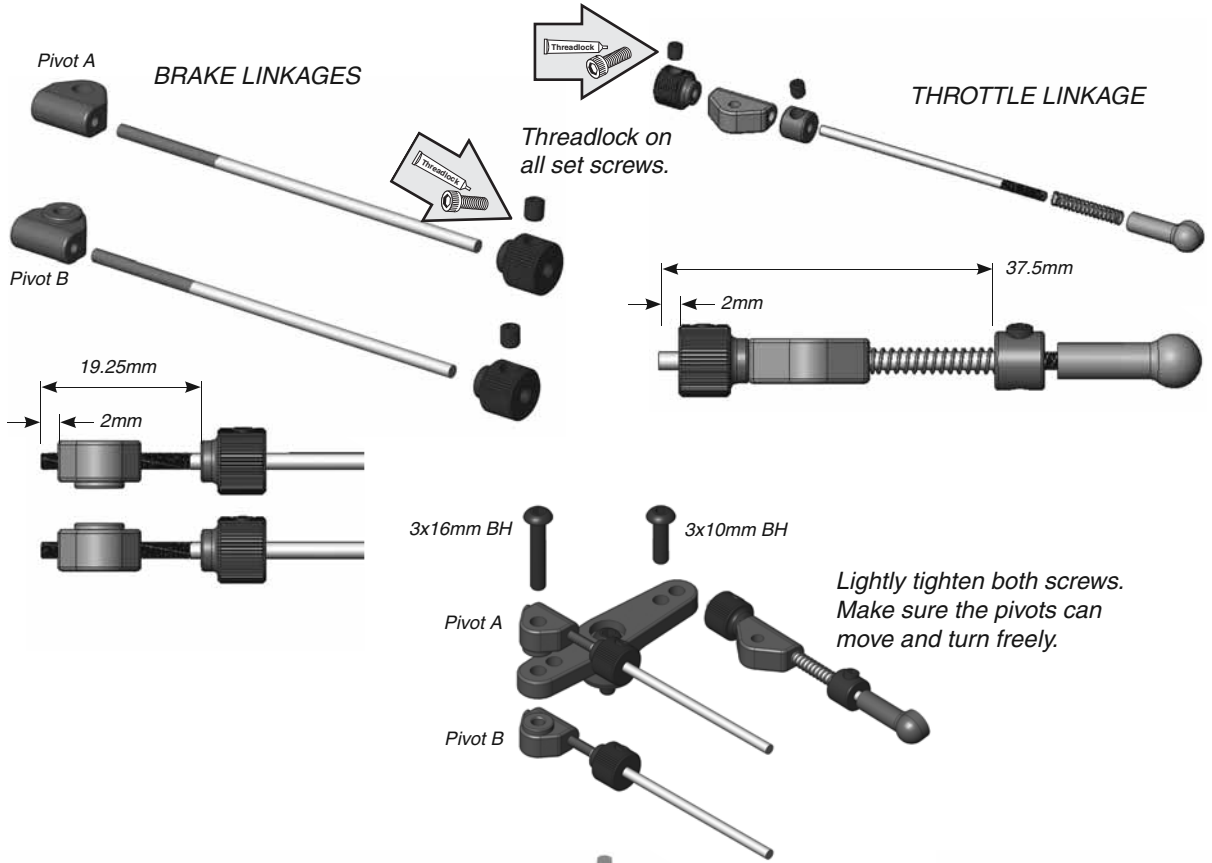

Throttle Servo	Spline Adapter
Airtronics®/Sanwa.....	23T
Futaba®/DuraTrax®.....	25T
Hitec®/Hobbico®.....	24T
KO Propo.....	23T
JP Propo.....	23T

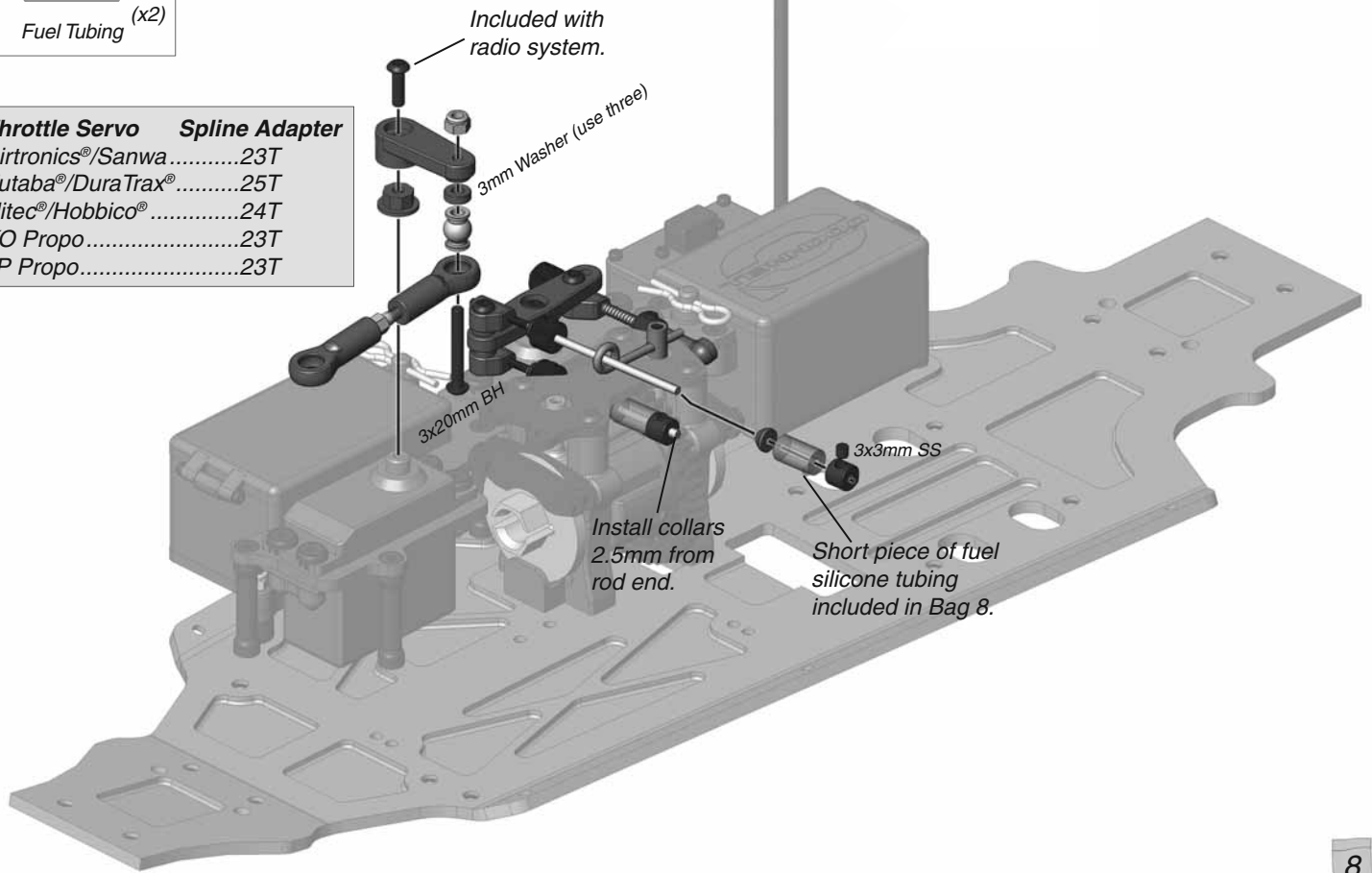

HARDWARE



(x2)
3mm Countersunk Washer



(x2)
3x18mm FH Screw



(x2)
3x14mm FH Screw

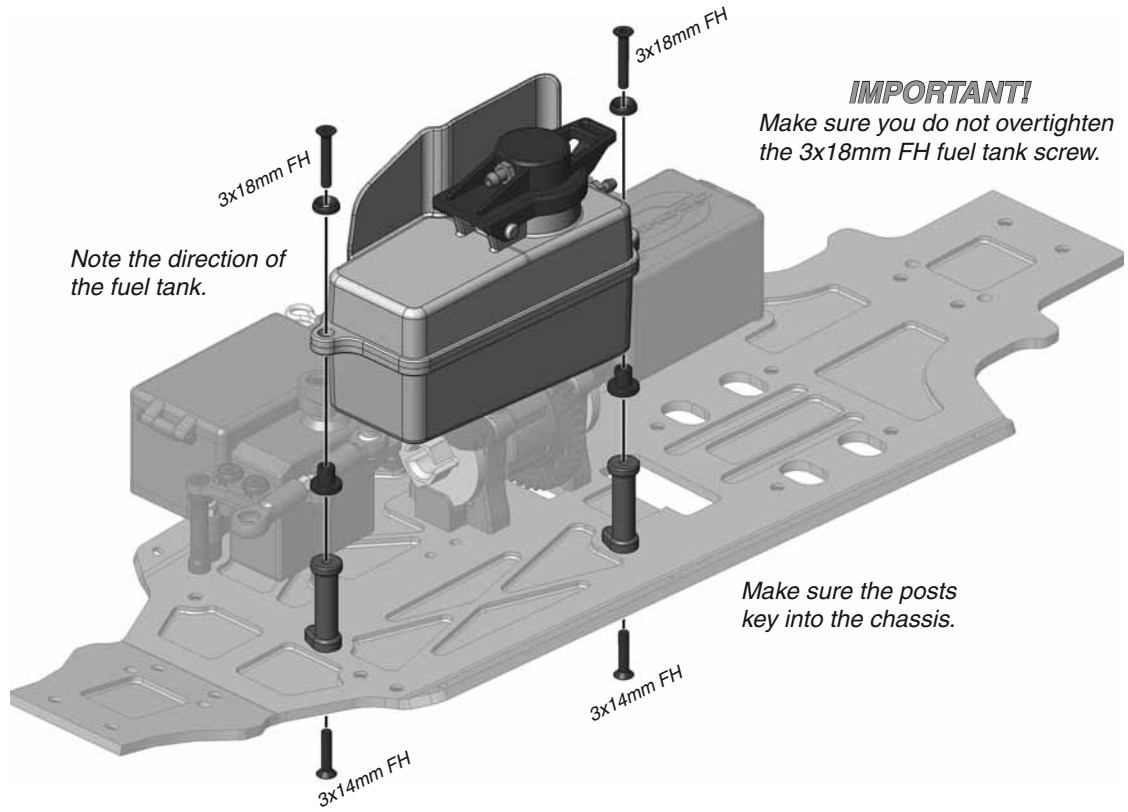

HARDWARE



(x6)
3x10mm FH Screw

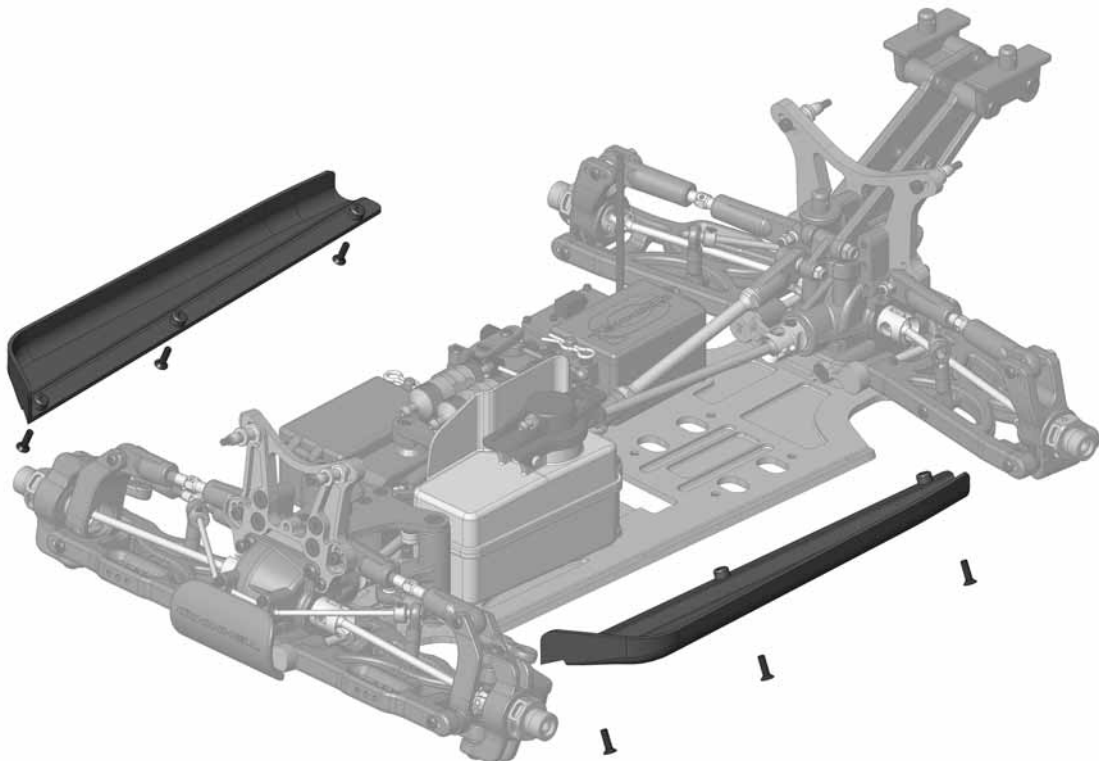

HARDWARE



(x1)

4x4mm Set Screw



(x1)

4x12mm FH Screw

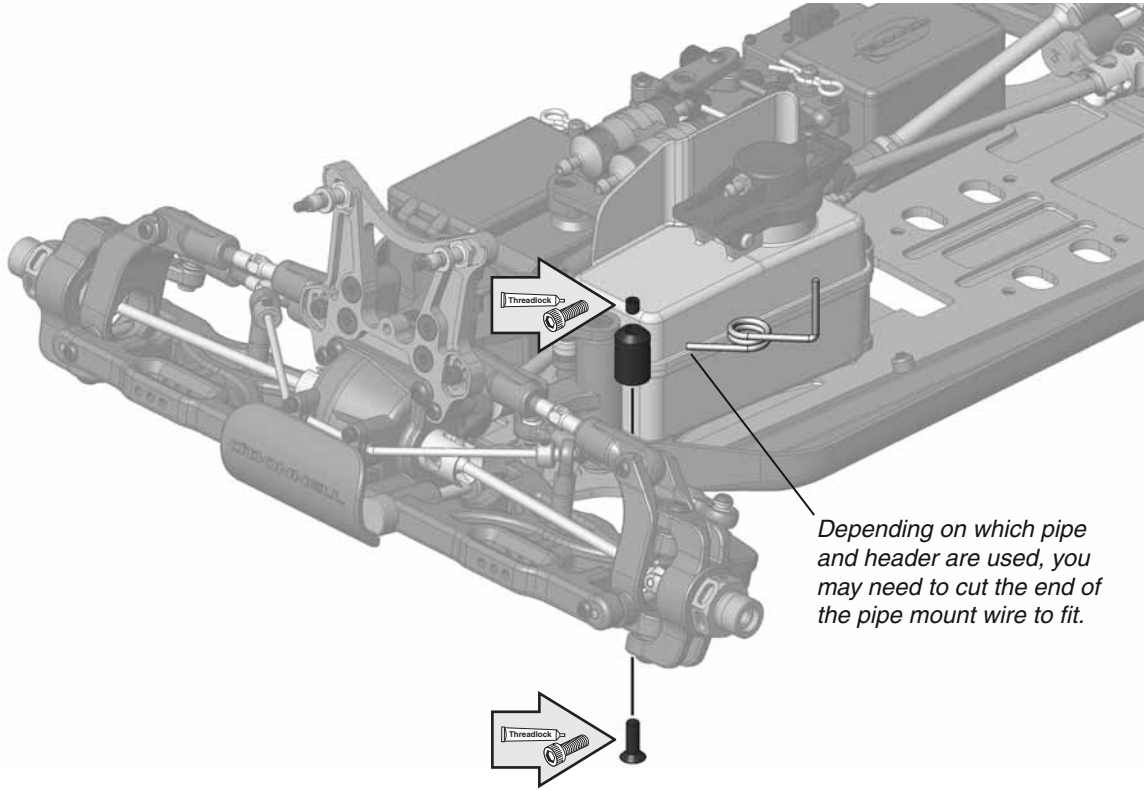

HARDWARE



(x4)

4x12mm FH Screw



(x4)

4x10mm SH Washer Screw



(x4)

4mm Lock Nut

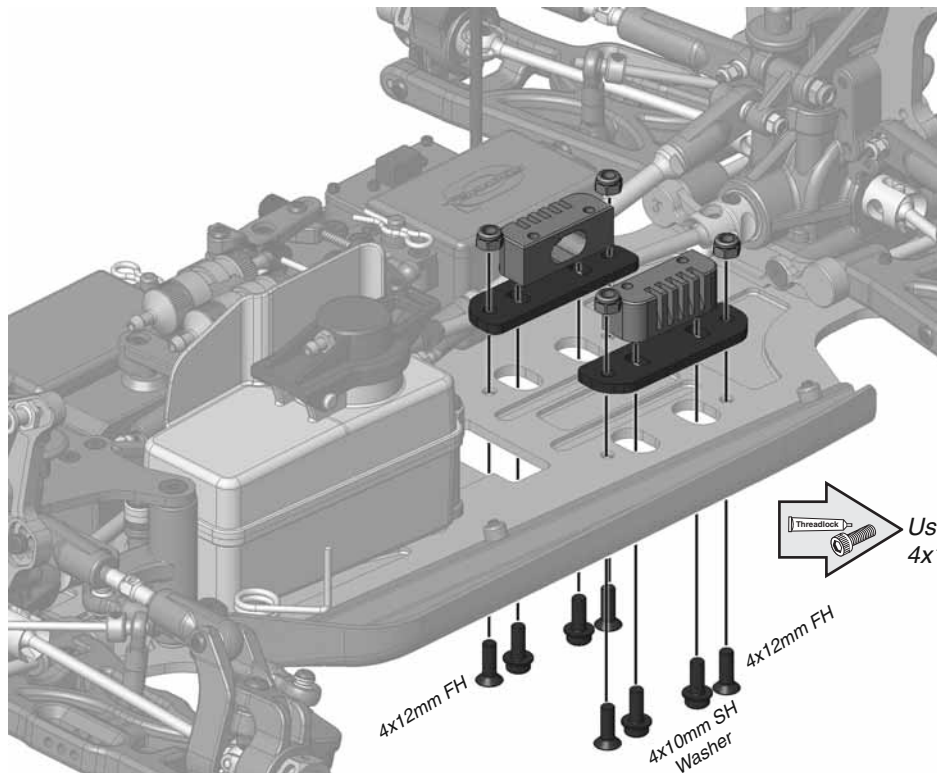

ENGINE SOLD SEPARATELY!

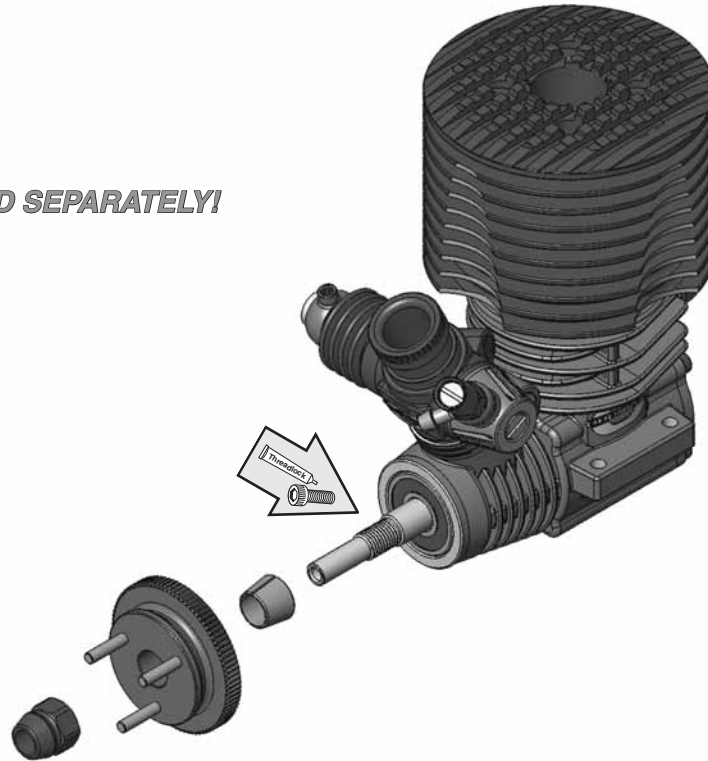

HARDWARE

 (x2)
5x10mm Bearing

 (x4)
Clutch Shim

 (x1)
3mm SH Screw with Washer

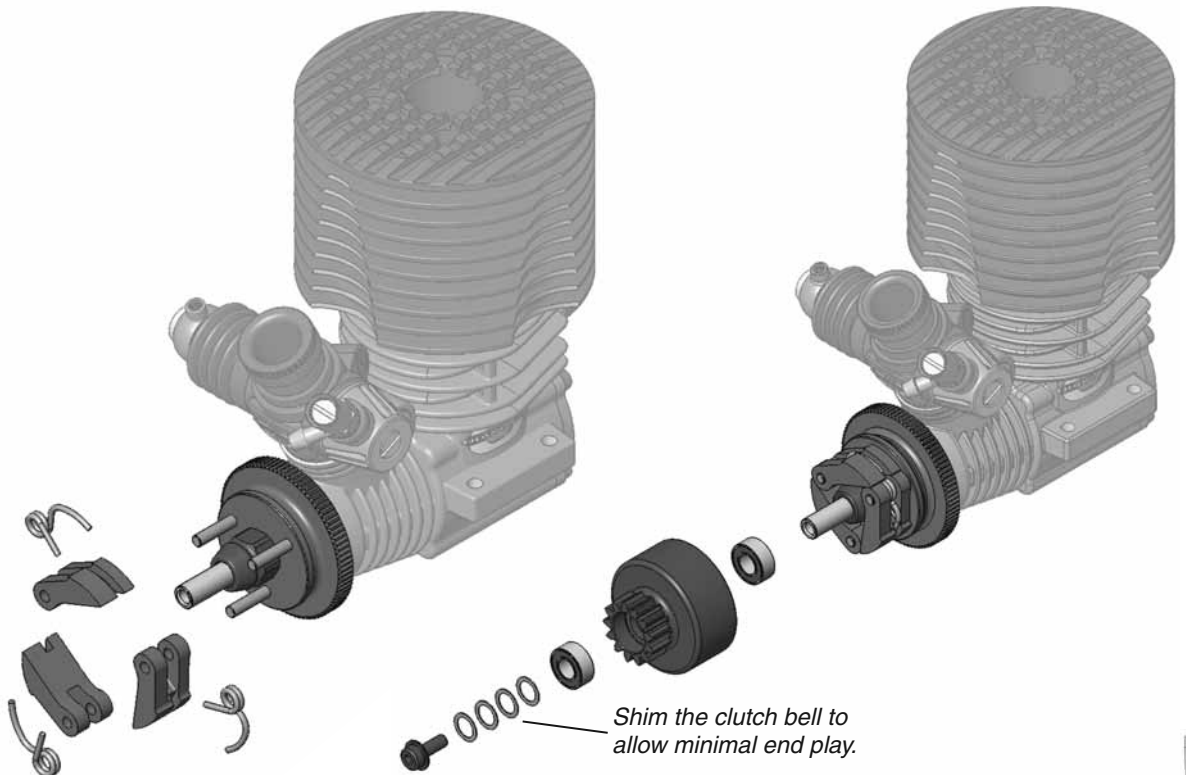

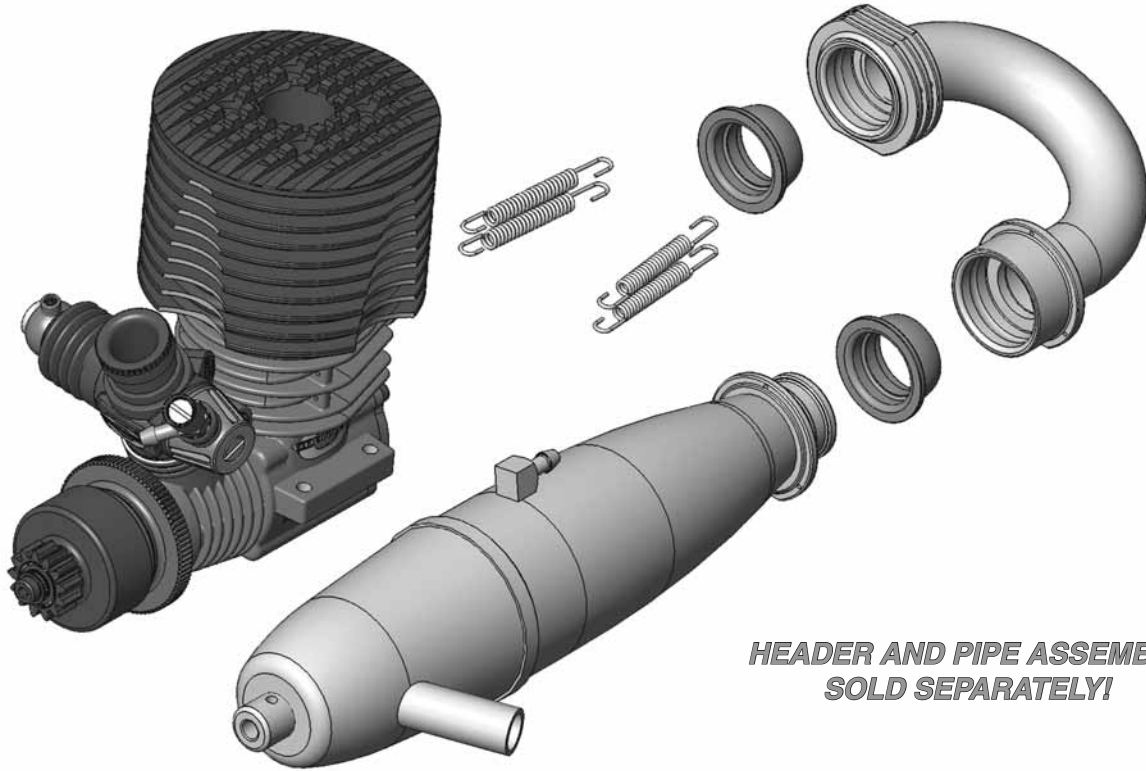

**HEADER AND PIPE ASSEMBLY
SOLD SEPARATELY!**

HARDWARE

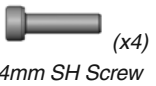

(x4)
3x14mm SH Screw

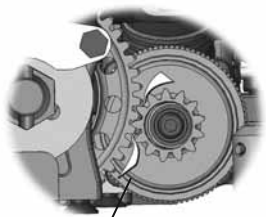

Place a strip of paper between the spur and clutch bell to help properly set the gear mesh. Once the gear mesh is set, remove the paper.

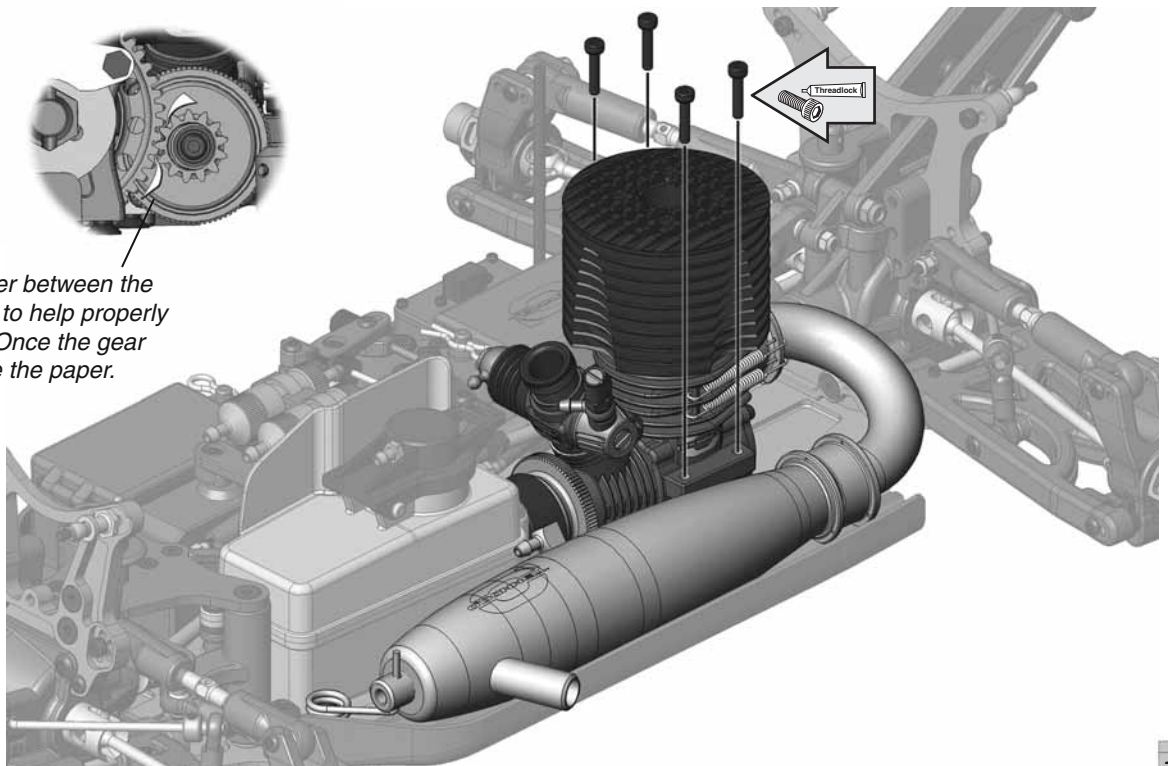

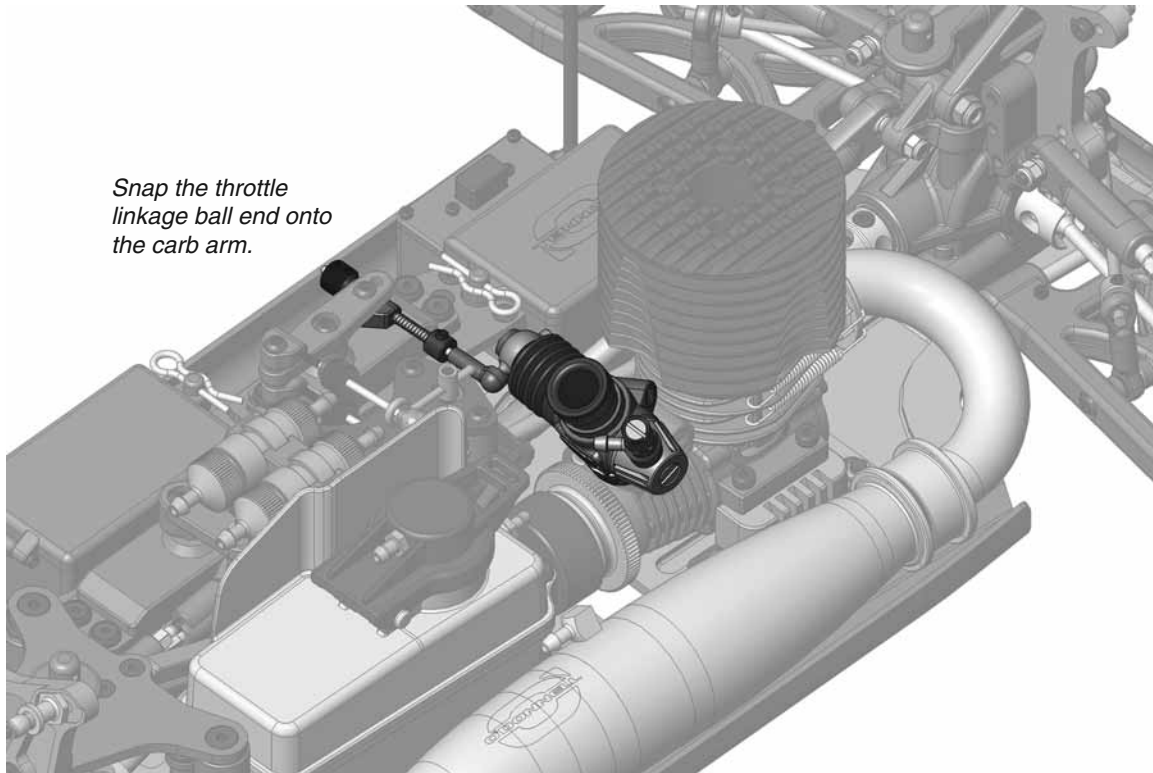

Snap the throttle linkage ball end onto the carb arm.

HARDWARE

(x4)
2-56x1/4" Button Head Screw

(x4)
2.5mm Washer

(x4)
3mm Washer (Silver)

Note: The notch in the 3mm silver washer does not affect shock performance and can be positioned in any direction.

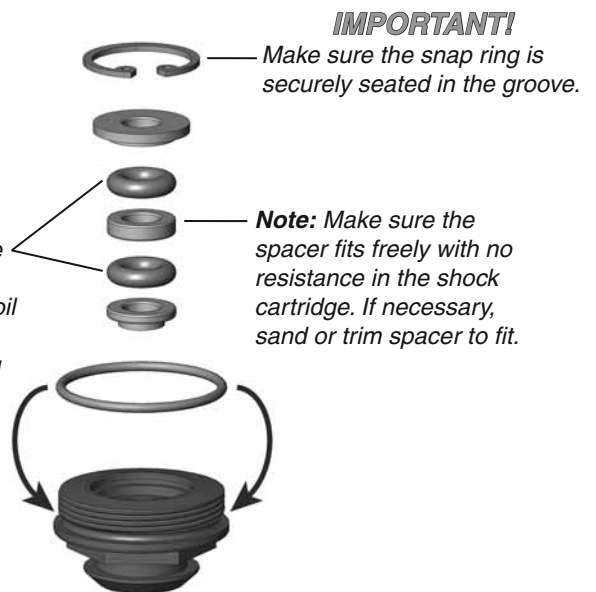
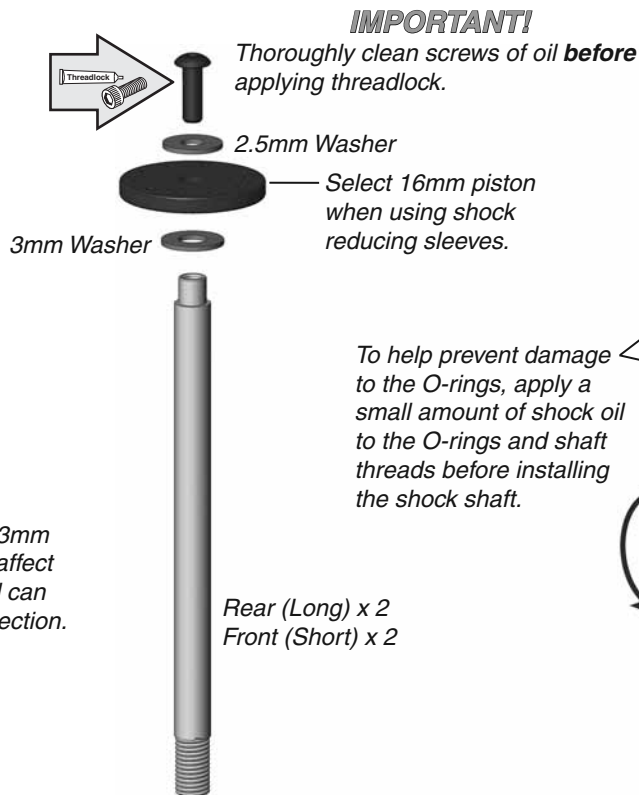

IMPORTANT!

When installing the shock cartridge into the shock body, be sure to not cross-thread the cartridge in the shock body. Press the shock cartridge into the bottom of the shock body and rotate the cartridge backwards until you feel the threads engage. Then thread the cartridge into the shock body until it bottoms out. GENTLY snug the cartridge (DO NOT overtighten!).

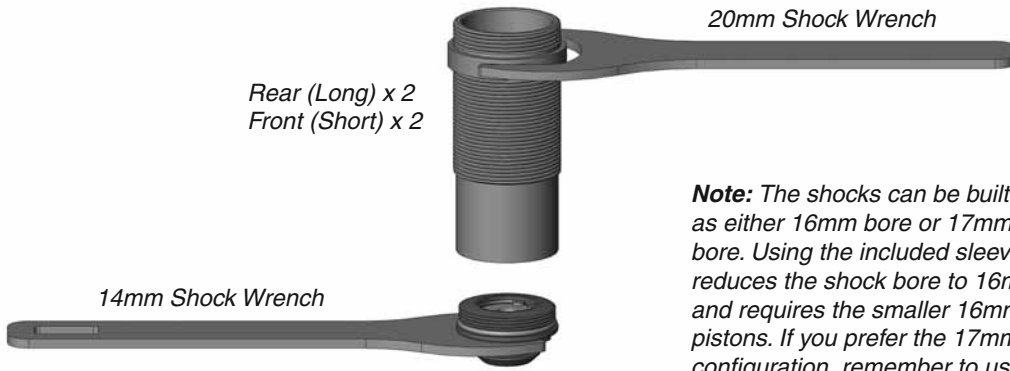

Note: The shocks can be built as either 16mm bore or 17mm bore. Using the included sleeves reduces the shock bore to 16mm and requires the smaller 16mm pistons. If you prefer the 17mm configuration, remember to use the larger 17mm pistons.



Note: Be sure to install the long shaft into the long body and the short shaft in the short body.

HARDWARE



(x4)

Shock End Ball

Be careful not to damage the shock shaft when installing the shock ends.



Fill the shock body with shock oil (with shock shaft fully extended, oil level should be just below the top of the shock body). Gently work the shaft up and down in the shock body to allow the air bubbles to work out of the oil.

Make sure the bladder is fully seated in the shock cap groove before installing it on the shock body.



IMPORTANT!

To avoid damage, DO NOT overtighten or use the hole in the cap when installing the cap on the shock body.

Slide the shock shaft up until the piston is to the top of the shock oil. Do not push the shock piston all the way out of the shock oil. Slowly thread the shock cap onto the shock body, allowing the excess oil to come out of the bleed hole in the shock cap. Using the included shock wrench, firmly tighten the shock cap.

Install the shock boot over the shock end and secure it in place on the shock body. Gently work the shock end out the bottom of the shock boot. The bottom of the shock boot should be firmly in place around the top of the shock end.



Be careful not to tear the shock boots during installation.

Thread the adjustable collar onto the shock body.



Make sure the spring retainer keys onto the tab on the shock end.

Rear (Long) x 2
Front (Short) x 2

51

FRONT SHOCK INSTALLATION

HARDWARE

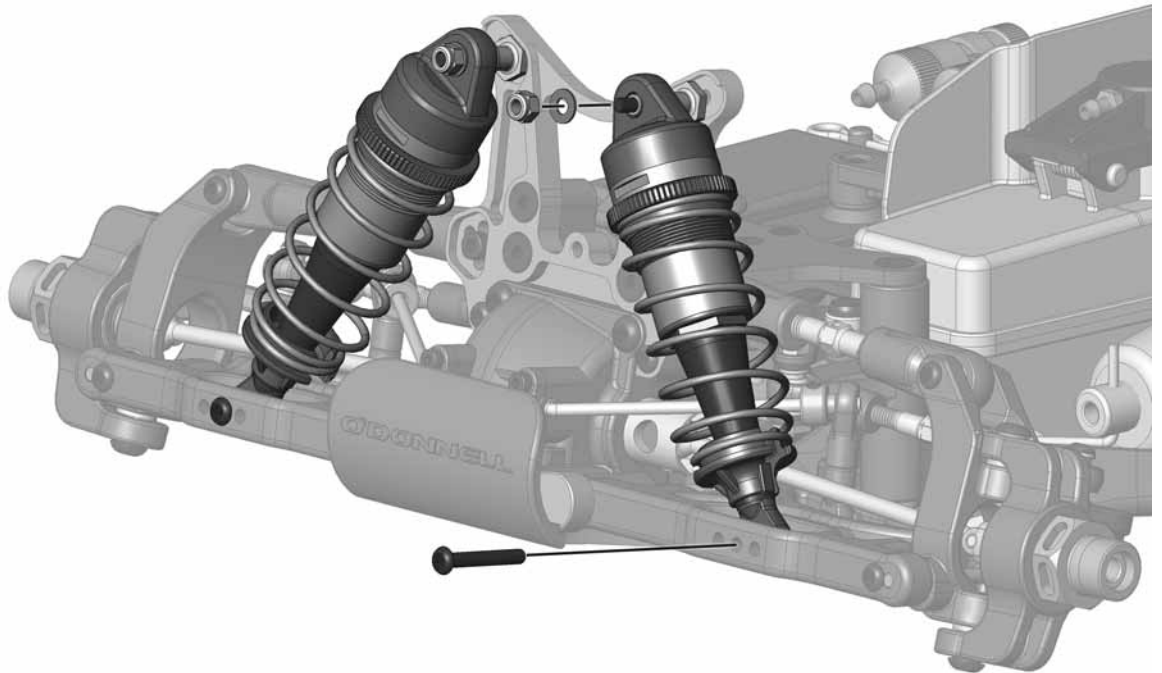

11

52

REAR SHOCK INSTALLATION

HARDWARE

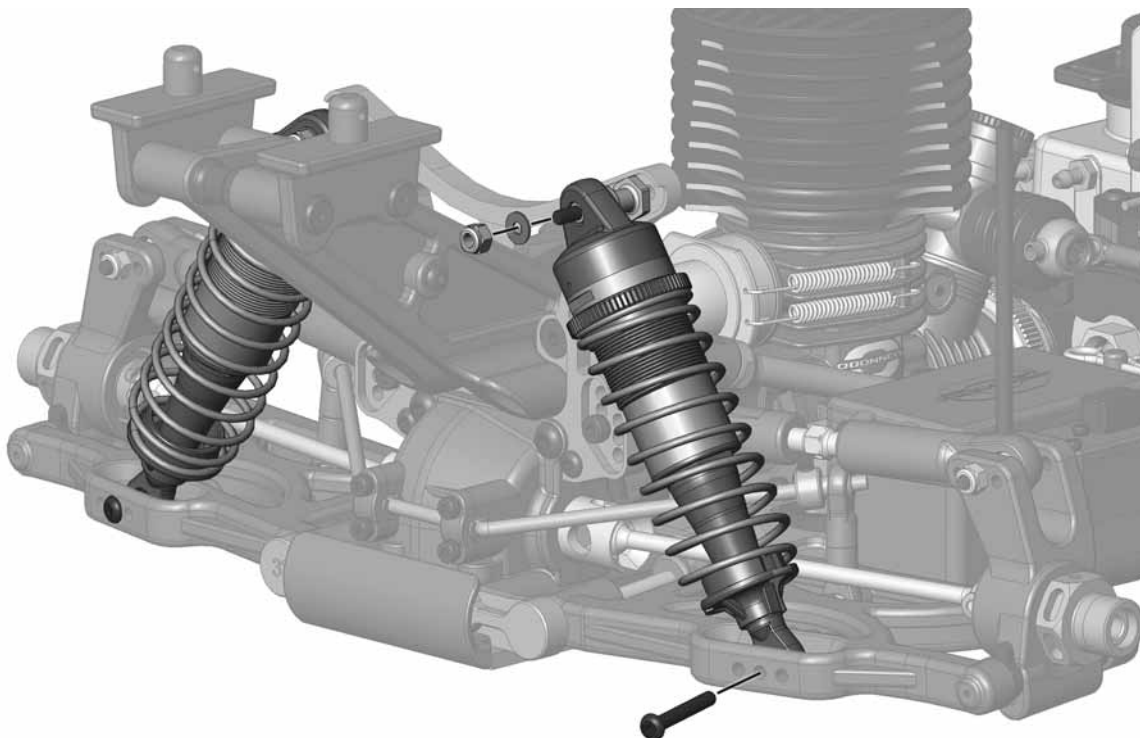

11

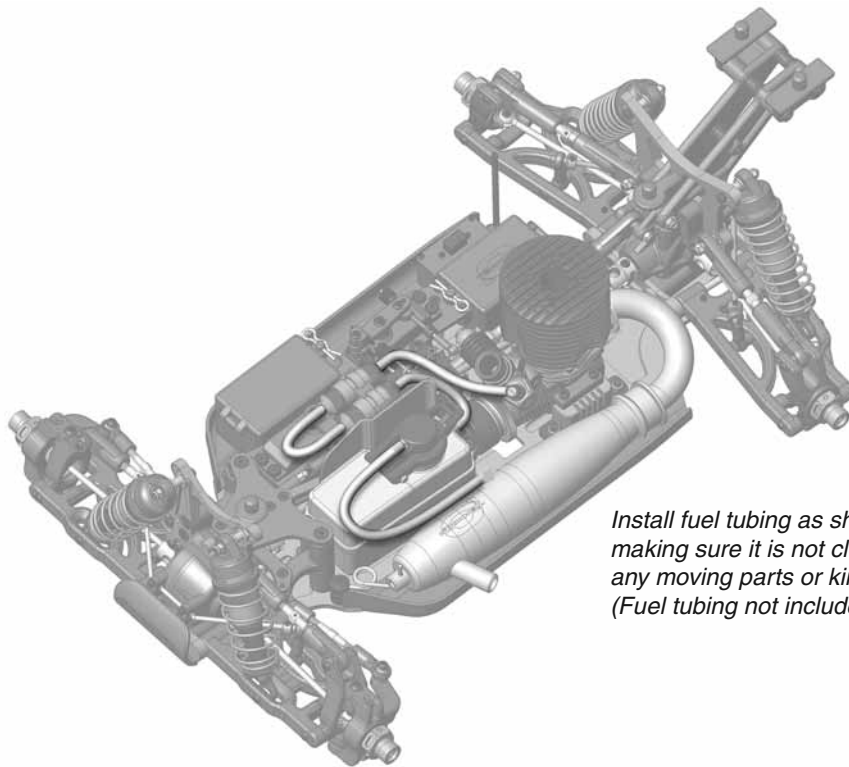

Install fuel tubing as shown, making sure it is not close to any moving parts or kinked. (Fuel tubing not included.)

HARDWARE

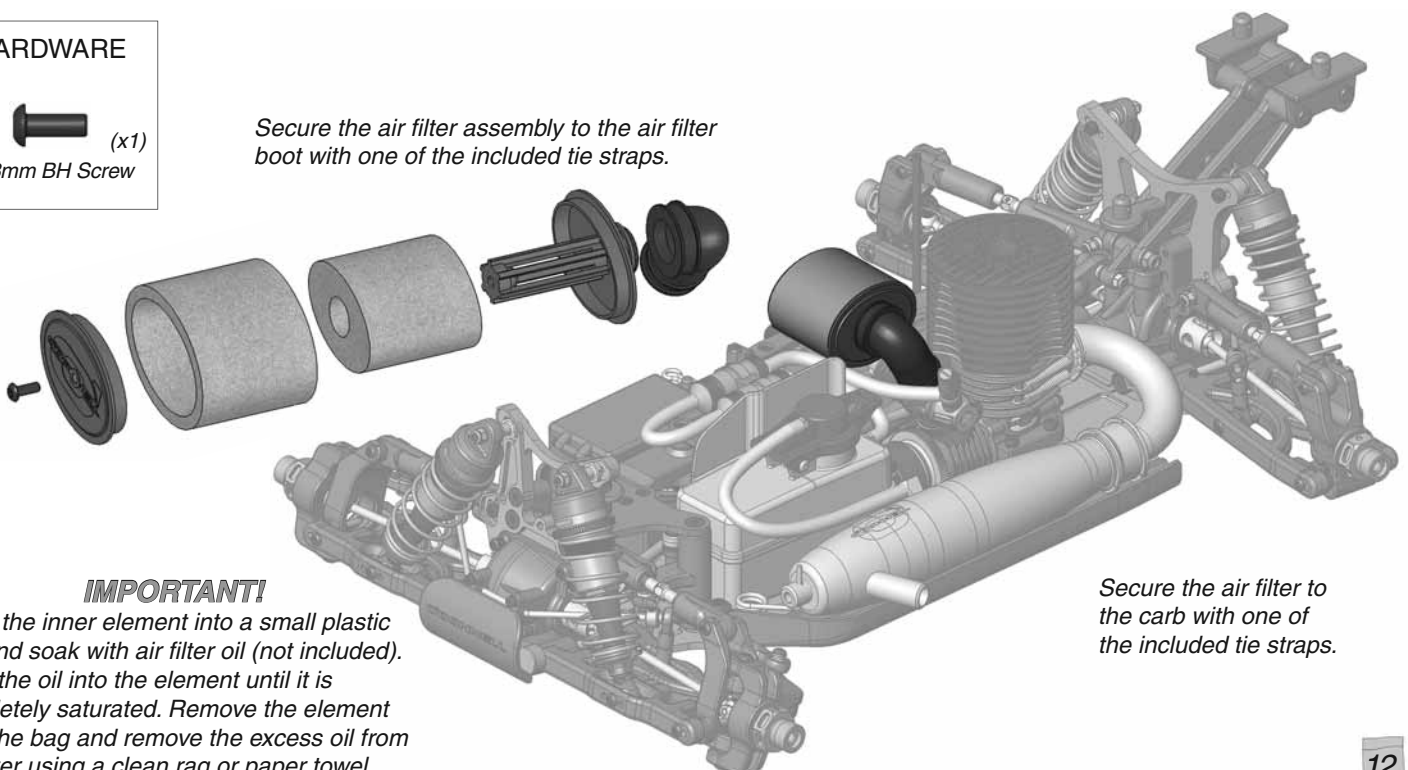

Secure the air filter assembly to the air filter boot with one of the included tie straps.

**IMPORTANT!**

Place the inner element into a small plastic bag and soak with air filter oil (not included). Work the oil into the element until it is completely saturated. Remove the element from the bag and remove the excess oil from the filter using a clean rag or paper towel.

Secure the air filter to the carb with one of the included tie straps.

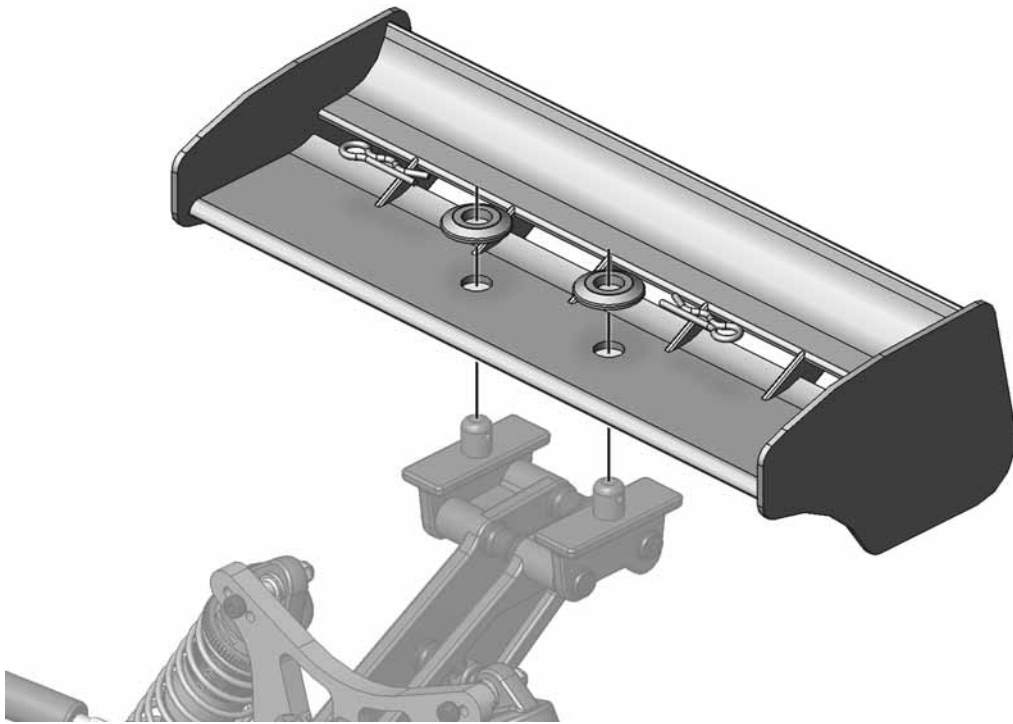

HARDWARE

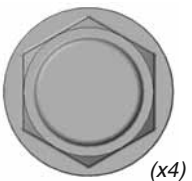

(x4)

Wheel Nut

Tires and inserts
sold separately.

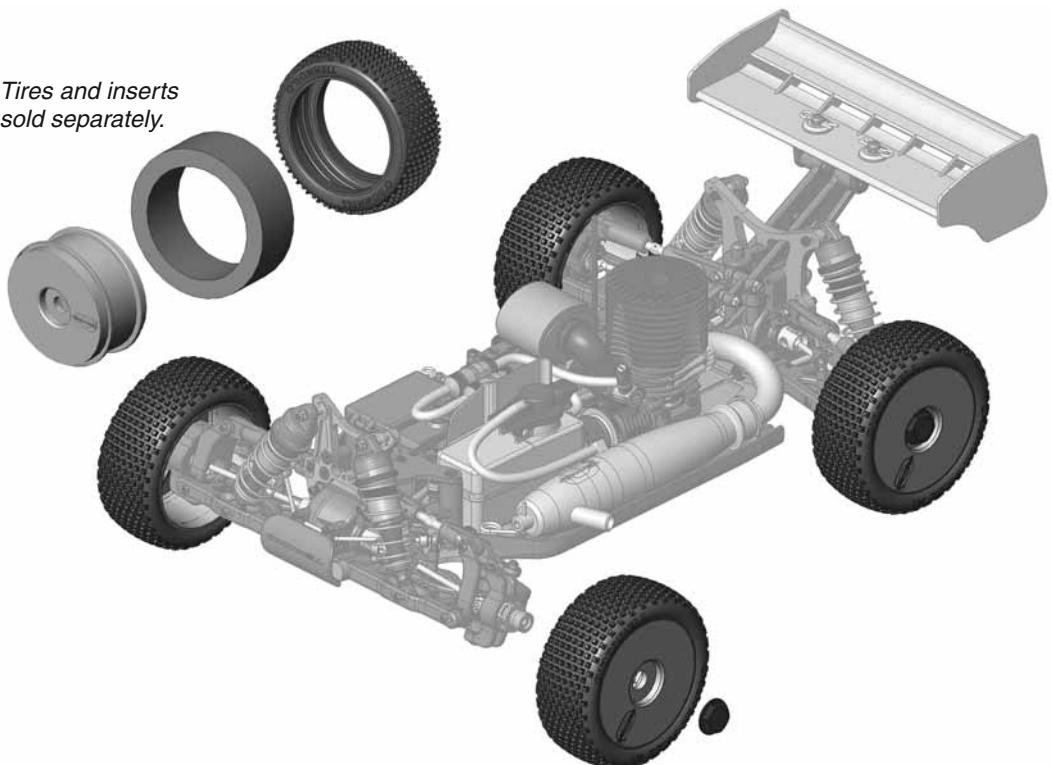

57

BODY

HARDWARE

 (x1)
3x8mm BH Screw

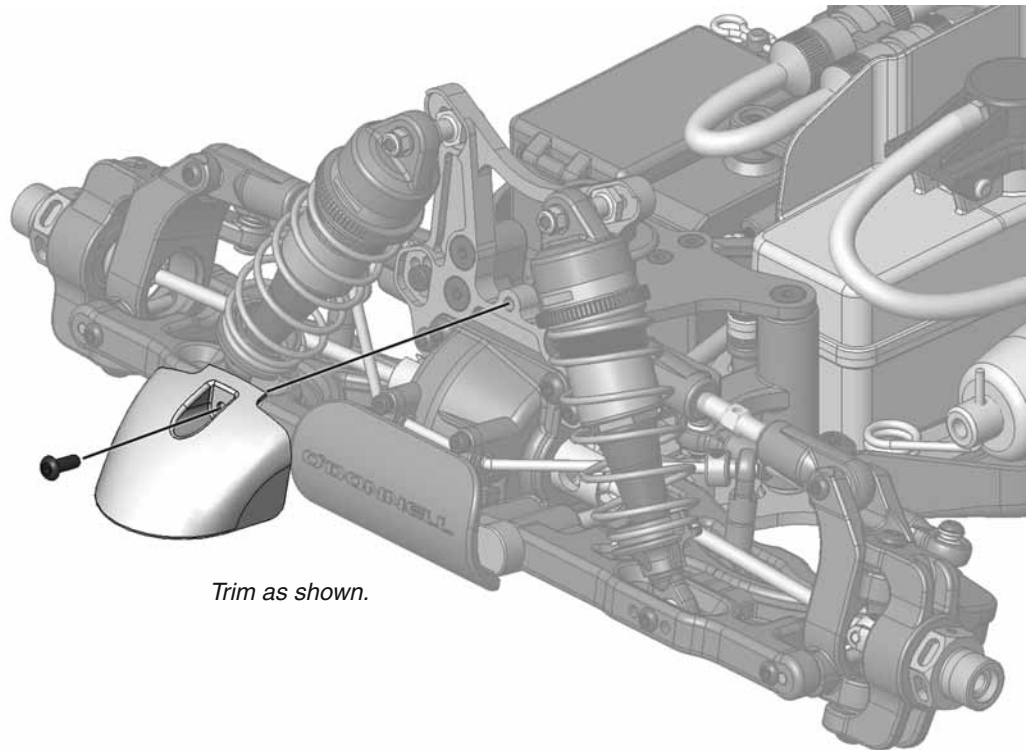

Trim as shown.

7

58

BODY

Trim body as shown.



