

# Z01B Tech Notice

## FUEL TANK

When mounting the fuel tank in the O'Donnell Z01-B, make sure you leave the upper tank mounting screws slightly loose to help protect against hard impacts or crashes.

Leave slightly loose.

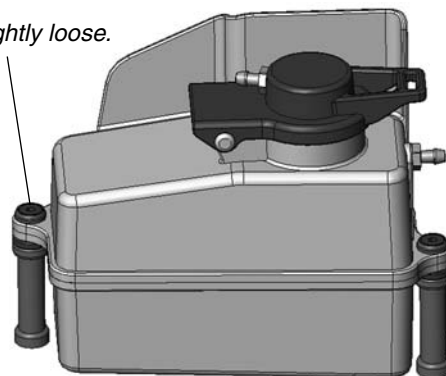

Leave slightly loose.

## SHOCK NUT ASSEMBLY

When installing the O-ring spacer into the shock nut make sure the spacer fits freely (no resistance) into the shock nut (this is very important). If there is resistance or a slight press fit, it will be necessary to slightly trim or sand the shock spacer to eliminate any resistance



Use a hobby knife or sandpaper to slightly trim the edges and smooth the sides.

## CENTER DIFFERENTIAL BULKHEAD

Make sure the brake cams move freely in the center differential bulkhead. If not, it will be necessary to slightly enlarge the holes in the bulkhead. Recommended drill bit size is #27 or 3.65mm. **DO NOT** drill any larger than 3.65mm.

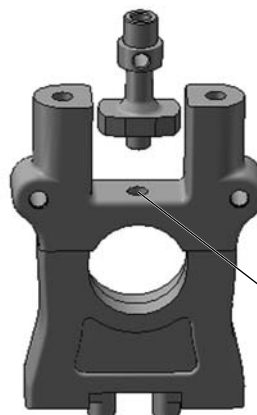

Slightly enlarge if necessary.