

S.E.5a



Important Information:

Please inspect the plane before beginning to assemble to make sure you are happy with it. After assembly has begun you cannot return the kit. If you find a problem before beginning to assemble the plane you must contact us, please do not return it to the dealer. Due to temperature changes the plane may develop some wrinkles in the covering that you will need to remove with an iron. Be sure to seal the edges down first so that you do not cause the covering to shrink and leave exposed areas of wood. The model is built light to ensure good flight characteristics. With the power available from the new breed of engines, it is necessary to use throttle management in order not to overstress the airframe. You must maintain good tight control linkage with no slop, good servos with plenty of power, and good servo arms to protect against flutter. Sloppy linkage and over speeding the plane will cause flutter which is not covered in the warranty. Lanier R/C is proud of the care and attention that goes into the manufacture of parts for its model kits. The company warrants that for a period of 90 days, it will replace, at the buyers request, any parts or material shown to the company's satisfaction to have been defective in workmanship or material at the time of purchase. No other warranty of any kind, expressed or implied, is made with respect to the merchandise sold by the company. The buyer acknowledges and understands that he is purchasing only a component kit from which the buyer will himself construct a finished flying model airplane. The company is neither the manufacturer of such a flying model airplane, nor a seller of it. The buyer hereby assumes the risk and all liability for personal or property damage or injury arising out of the buyers use of the components or the finished flying model airplane, whenever any such damage or injury shall occur. Any action brought forth against the company, based on the breach of the contract of sale to the buyer, or on any alleged warranty there under, must be brought within 1 year of the date of such sale, or there after be barred. This one year limitation is imposed by agreement of the parties as permitted by the laws of the state of Georgia.

Lanier R/C, INC. P.O. Box 458 Oakwood, Ga. 30566 PH 770 532 6401

© copyright 2006 Lanier R/C

USING THIS INSTRUCTION MANUAL

Before you begin assembling your **S.E.5a ARF**, take some time to read through this entire instruction book. It is designed to take you step-by-step through the process and to give you added information on motor and radio selection and set-up, balancing your aircraft, and flying your model. The time you spend will speed the assembly process and help you avoid problems.

PREPARING FOR ASSEMBLY

You will need a work area of approximately 24 x 48" which has been covered to protect it from adhesive, as well as cuts and other damage. Many people cover their work area with a sheet of dry wall (sheet rock) and/or waxed paper to prevent CA Glue and Epoxy from ruining the work surface.

CONSTRUCTION TIPS

IMPORTANT: ALWAYS READ A FEW STEPS AHEAD. This will alert you to coming instructions and will help you plan accordingly.

Using the Parts Identification section, familiarize yourself with the various items included in your kit box.

Do not hesitate to ask questions. Your local hobby dealer and area flyers will most likely be happy to help, as they want you to have a successful flying experience.

ADHESIVES & GLUING TECHNIQUES

CA adhesives are specially formulated to firmly glue the plywood, hardwood, and balsa used in your model and to withstand the vibration and stresses of high performance flight. However, there are times, such as when you are installing the stabilizer and fin on the fuselage and want more set-up time for careful alignment and positioning, then you should use epoxy. Occasionally, you also will want to use thin CA, which "wicks" into the surrounding areas. Aliphatic resin glue or similar water-based glues can also be used, but they will add to the assembly time because they dry so much more slowly than CA glue. Remember, when ever using any CA, you must be careful to read instructions thoroughly, as you will have only seconds for positioning of parts. Be sure to trial fit parts together before gluing. Also, never use watery THIN type CA glue for gluing plywood and hardwood parts. Thin CA's do not adequately bond these areas.

CAUTION

Some people may experience an allergic reaction when exposed to fumes from CA glue or epoxy. As with paints, thinners, and solvents, it is always important to use glues only where there is adequate ventilation to carry fumes away. A fan is recommended. Also, special care must be taken when using CA, as it will bond skin as well as other surfaces. Before using any CA, carefully read all label precautions. When using CA, protective eye-wear and care in keeping the glue away from the face is highly recommended. If CA does happen to get into the eye, hold lid open and flush with water only. Seek immediate medical attention.

COVERING

The **S.E.5a ARF** is covered in a polyester film chosen for its beauty, toughness, and ease of application and repair. It is not uncommon for ARF's to develop a few wrinkles in transit. If this is true of your model, the situation is easily corrected. Before you begin putting the pieces together, run around the edge of the seams first then over the surface of each section with an iron (either specially designed for airplane use or the more cumbersome household iron). Apply the heat (set at about 300° F), following along with a soft cloth and pressing down on the covering as you go around. This will more firmly set the covering adhesive into the wood and keep your aircraft covering tight and smooth in the future. Once you have ironed the seams stay away from them with the heat or the covering will slide when you try to shrink the middle. If this happens the wrinkles will not come out of the covering.

One of the great advantages of polyester film is that it can be applied over itself without causing gas bubbles. This allows you to repair your aircraft, as well as to customize it in a number of ways. If, due to a flight mishap, you get a hole or similar covering damage, simply trim away the ragged edges and then apply a patch, following the directions that come with your covering, which is available at your hobby dealer.

The S.E.5a covering can be closely matched using

Oracover Red #871

Oracover White #870

Oracover Olive Drab #904

Oracover Blue #873

Oracover Cream #878

ITEMS NEEDED TO COMPLETE THIS AIRCRAFT

- 1 4 CHANNEL RADIO WITH 4 MICRO SERVO. (WE USED 4 CHANNEL **FUTABA** RADIO WITH S3110 SERVO AND **FUTABA** RECEIVER)
- 1 6" SERVO "Y" HARNESS
- 2 12" SERVO EXTENSIONS
- 1 ELECTRONIC SPEED CONTROL (WE USED A **CASTLE CREATIONS** PHOENIX 25 BRUSHLESS SPEED CONTROL)
- 1 3 CELL LI-PO BATTERY (**GREAT PLANES** ELECTRICFLY 1500)
- 1 **ULTRAFLY** BRUSHLESS MOTOR A/30/29 WITH 3.89 GEAR RATIO
- 1 **GREAT PLANES** ELECTRIFLY PROP ADAPTER 3MM APC LONG
- 1 **APC** PROPELLER 9 X4.7 SLO FLYER
- 1 CA ACCELERATOR
- 1 1 OZ. BOTTLE CA MEDIUM GLUE
- 1 1/2 OZ. BOTTLE CA THIN GLUE
- 1 5 MINUET EPOXY
- 1 1/4" FOAM RUBBER
- 1 SHEET METAL SCREWS FOR MOTOR(MIGHT BE REQUIRED FOR SOME MOTOR INSTALLATIONS)

TOOLS AND SUPPLIES FOR ASSEMBLY.

- MODELING OR UTILITY KNIFE
- WORK SURFACE (24" X48")
- SMALL STANDARD & PHILLIPS SCREWDRIVERS
- MASKING TAPE
- NEEDLE NOSE PLIERS
- 24" RULER
- FLEXIBLE STRAIGHT-EDGE
- 30-60-90° x 6" TRIANGLE
- SOFT PENCIL
- A FEW STRAIGHT OR "T" PINS
- WIRE CUTTER (DYKES)
- OPTIONAL HEAT GUN/COVERING IRON
- ACID BRUSH
- 5 FT. LENGTH OF STRING

Caution:

Before starting, carefully go over all high stress areas (Wing bolt mounting blocks, Firewall,etc.) with an epoxy or wood glue to confirm all areas are well glued.
Warnings about Lithium

Polymer batteries

NEVER charge Lithium Polymer batteries with a charger designed for NiCd, NiMH, or any other type of battery chemistry. Use ONLY the chargers listed under REQUIRES or equivalent substitutes.

Do not allow Li-Po cells to overheat at any time. Cells which reach greater than 140° Fahrenheit (60C) will usually become damaged and could catch fire.

Do not charge or discharge Li-Po cells on or near combustible materials including paper, plastic, carpets, vinyl, leather, wood, inside an R/C model or full size automobile.

Do not expose Li-Po cells to water or moisture at any time.

Do not store batteries near an open flame or heater.

Do not assemble Li-Po cells or pre-assembled packs together with other Li-Po cells or packs.

Do not allow a Li-Po battery to be left unattended during charging or discharging.

Always store Li-Po batteries in a secure location away from children.

Always remove a Li-Po battery if model is involved in any kind of crash. Carefully inspect the battery and connectors for even the smallest damage.

CAUTION, cells may be hot!

Do not allow the electrolyte to get into eyes or on skin. Wash affected areas immediately if they come into contact with electrolyte.

Aileron Control Horns

- Gather the following items:
 - (6) Small Control Horns
 - (2) Wing
 - (2) EZ Connectors With Hardware
 - (2) Swivel Keeper



- Cut the back plate off the side of the control horn.

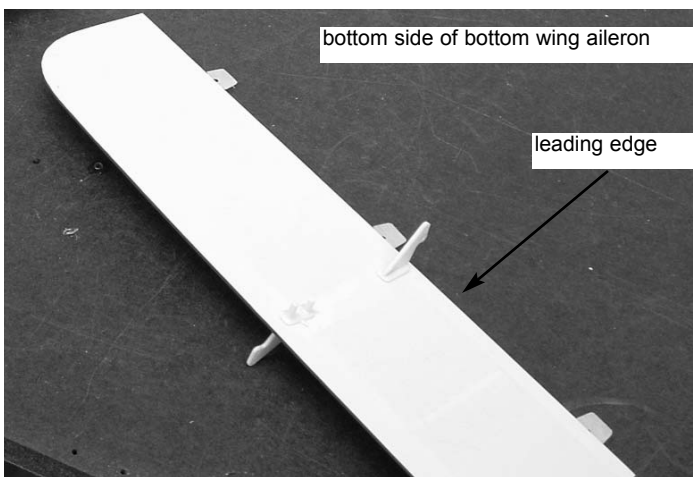

- Locate the pre-drilled control hole holes in the aileron. The control horn on the bottom side faces toward the leading edge of the aileron. The other control horn goes on the top side of the aileron and faces the trailing edge.
 - Place glue on the control horn pins and insert them in the holes.
 - Place the plate on the pins on the opposite side and glue in place.

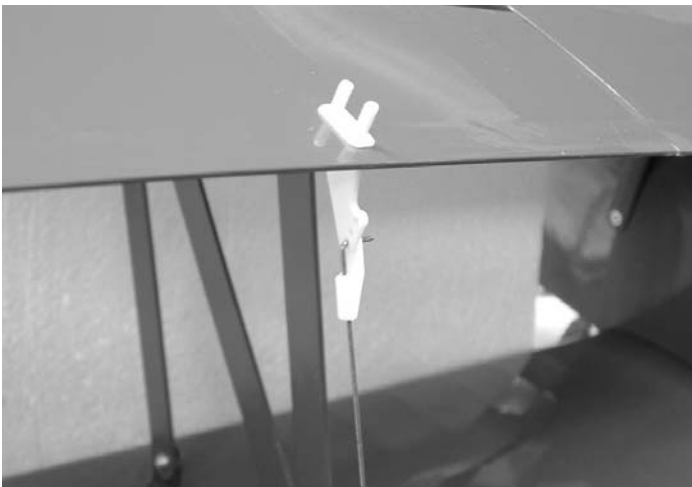

- Install the two control horns on the top wing ailerons on the bottom side facing the rear.

Installing Ailerons

- Collect the following parts:
 - (2) Wings
 - (4) Ailerons (Left & Right)
 - (12) Mini CA hinges

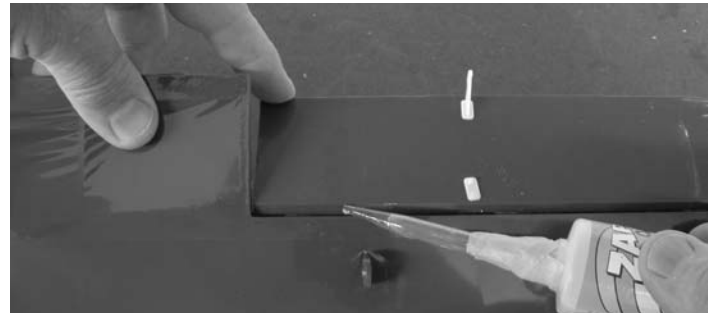

- Locate the pre-cut aileron hinge slots in both sides of the wing. Using a hobby knife (#11 blade), slide the blade into each slot to make sure it is cleanly cut.
 - Repeat this process with the ailerons, making sure all hinge slots are clean.
- Insert the mini CA hinges half way into the wing and the ailerons. (Use a pin inserted into the middle of the hinge to help keep the hinge in the middle.)
 - Make sure that the aileron is tight against the wing and even with the wing tip.
 - Using thin CA glue, place one drop on all hinges top and bottom.
 - Repeat for the other three ailerons.

Installing Aileron Servos

- Gather the following items:
 - (2) 12" Extension wires
 - (1) Bottom Wing
 - (2) Servos
 - (1) Electrical tape
 - (2) Servo spacers

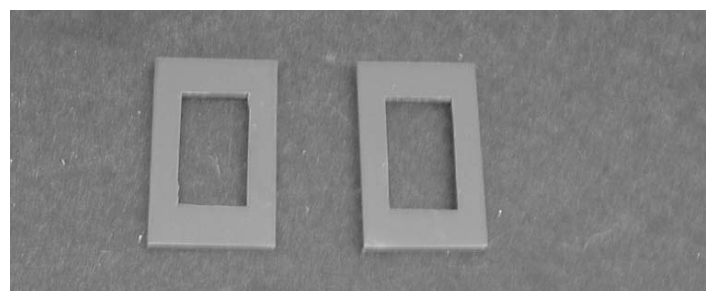

- Locate the two aileron servo spacers.



- Lay the spacer over the cutout for the aileron servo and mark around the outside edge.
 - Carefully remove the covering inside your marks and glue the spacer plate in place.
- Use the string to pull the aileron wires through the wing and exit the hole in the center section.

IMPORTANT! To ensure that any connections located inside the wing will not come loose, either when the wires are pulled, or during flying, always tape them securely together with electrical tape.

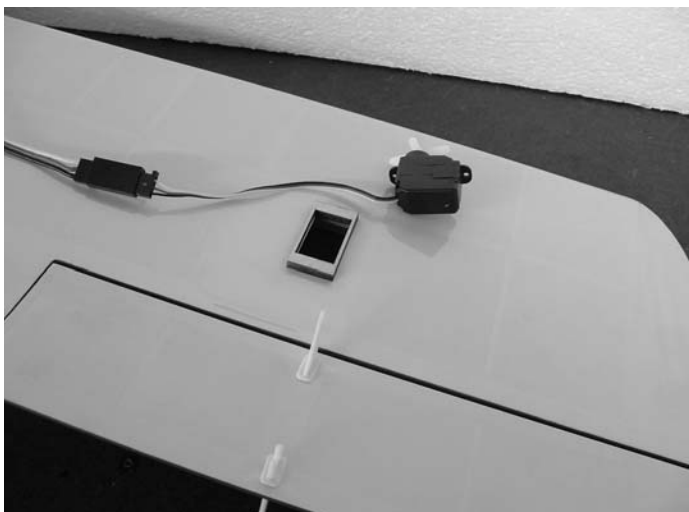

- Mount the servo using the hardware supplied with the servo.
- Repeat for the other wing.

Aileron Pushrods

- Gather the following items:
 - (2) 12" Extension wires
 - (1) Bottom Wing
 - (2) Servos
 - (1) Electrical tape
 - (2) Servo spacers

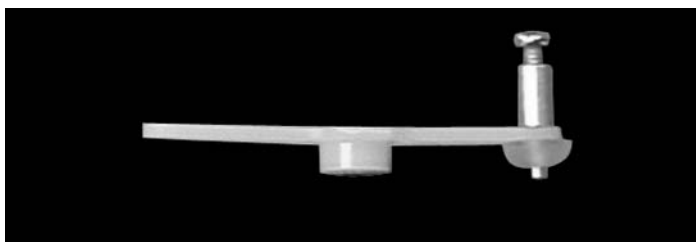
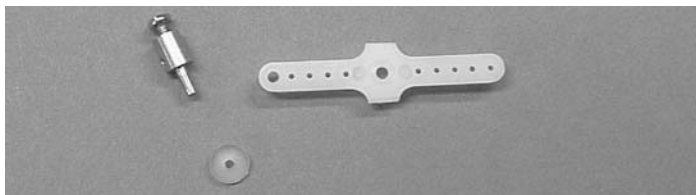

- Mount the EZ connector hardware on the aileron servo arm.



- Find the small aileron pushrod wire.
 - Make a 90° bend (or a "z" bend, if preferred) 1/4" from the end of the wire
 - Insert the wire into the control horn.
 - Secure the wire with a nylon swivel keeper.
- Insert the other end of the push rod through the EZ connector.
 - Mount your servo arm on top of your servo.
- Repeat for the other servo in the other wing.

Main Landing Gear

1. COLLECT THE FOLLOWING PARTS:
 - (1) Fuselage
 - (1) Main Landing gear
 - (4) #2 x 3/8" screws
 - (2) Main Wheels
 - (2) nylon wheel retainers
 - (2) landing gear straps

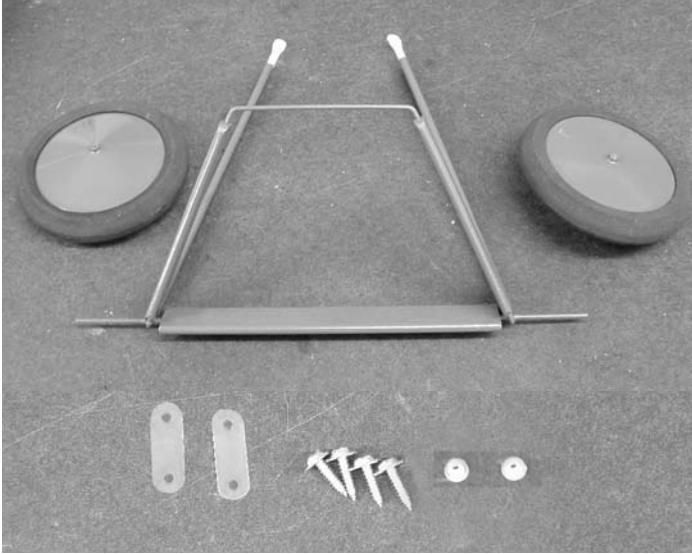

3. Fit the gear into the slot on the bottom of the fuselage.
 - Swing the two straps into place over the wire and install the other two screws. The two rear supports go under the wing mounting bolts when the bottom wing is installed.

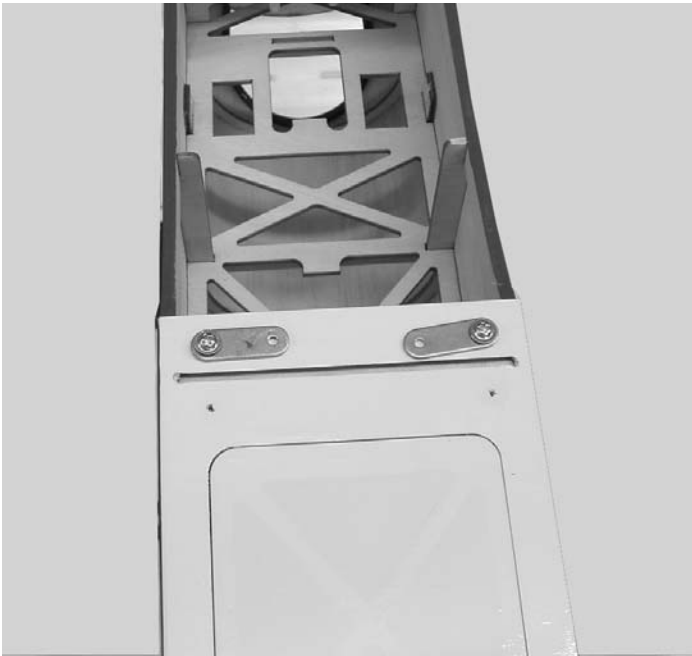

2. Use two of the screws and mount the landing gear straps to the fuse in the rear holes.

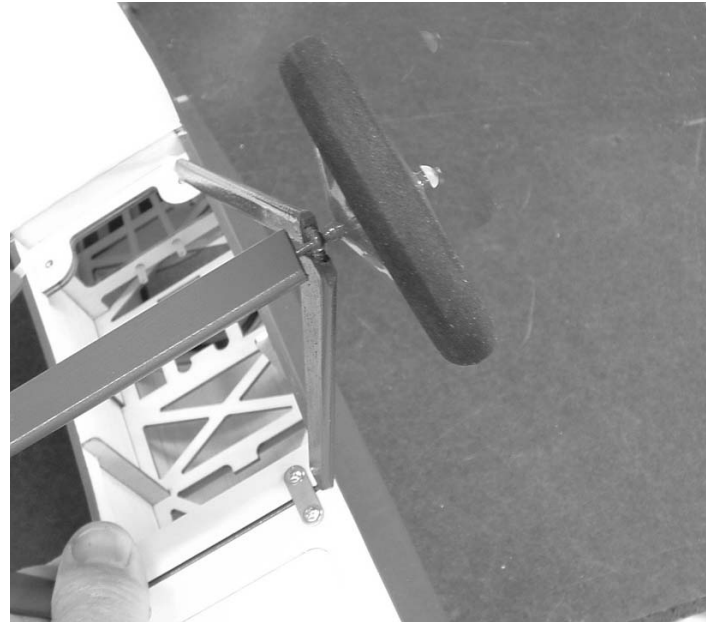

4. Fit the main wheel on the axle and hold in place with the press on nylon keeper.
 - Repeat for the other wheel.

Installing Stabilizer

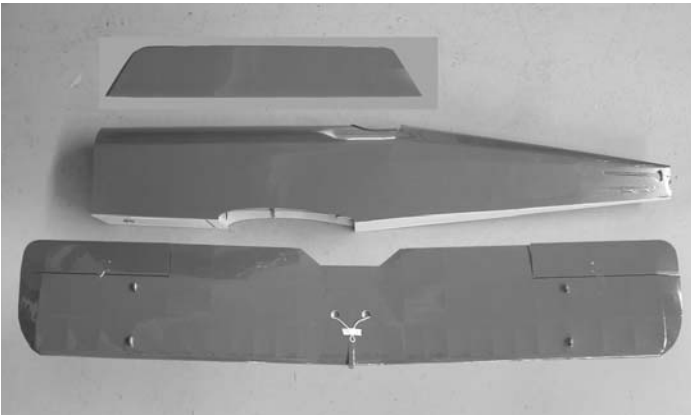

1. COLLECT THE FOLLOWING PARTS:
(1) Fuselage
(1) Stabilizer
(1) Bottom wing
(2) #4 x 3/4" screws

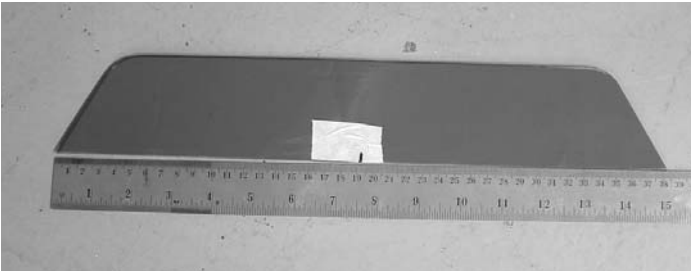

2. Put a piece of masking tape along the trailing edge of the stab and measure and make a mark in the center of the stab.

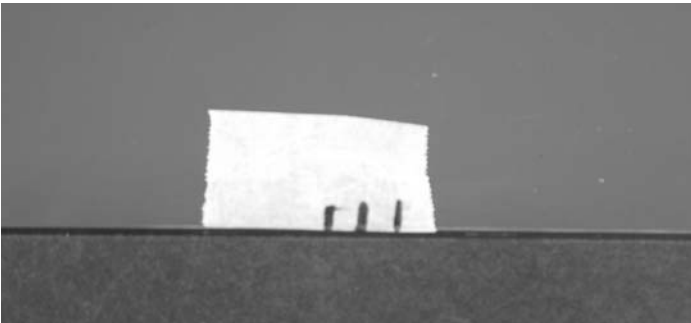

3. Make another mark on each side of the center line 1/4" over. These two marks will line the stab up in the center of the fuselage at the rear.

4. Mount the bottom wing to the fuselage using the two #4 x 3/4" bolts.

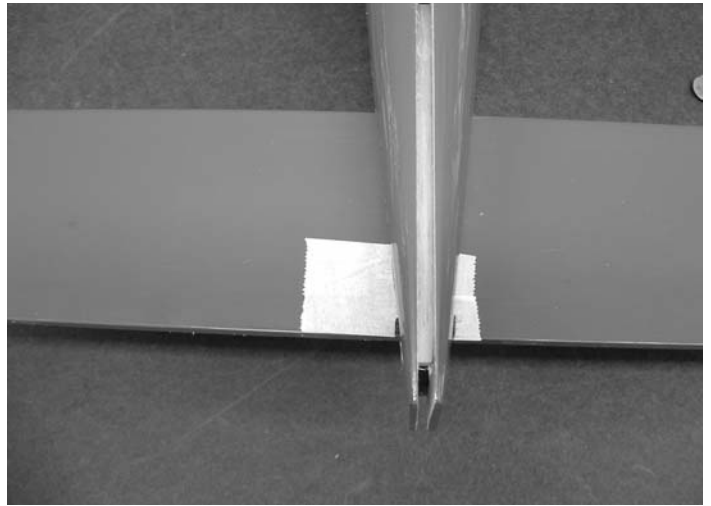

5. Slide the stab into the fuselage and align the center marks on both sides of the fuselage.

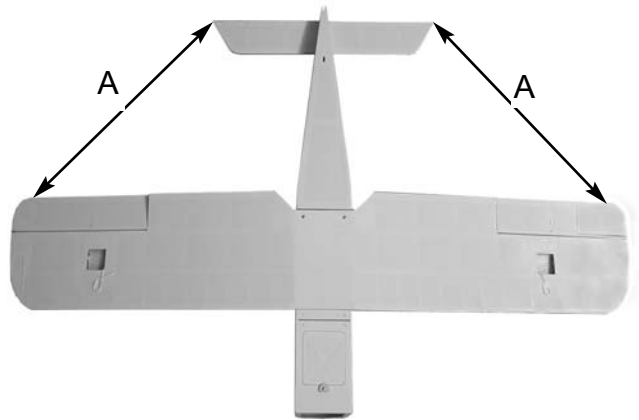

6. Measure out the wing on each side an equal distance and make a mark. Measure from the tip of the stab to the mark on the wing and adjust stab until both sides are the same (A equals A)

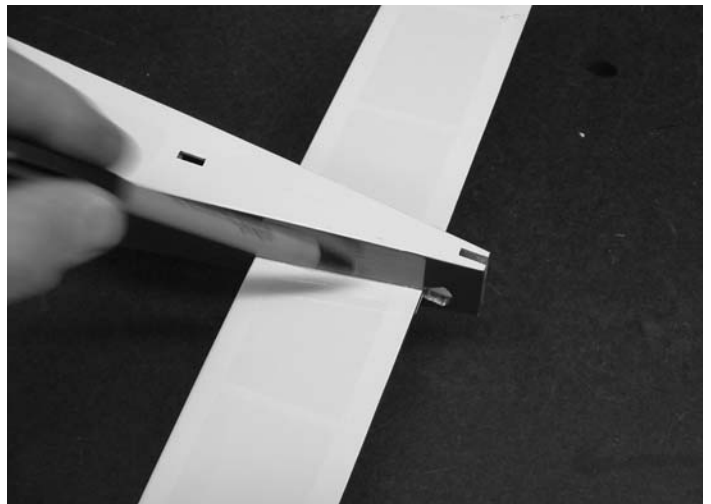

7. When stab is properly aligned, make a mark along side the fuselage on the stab top and bottom, left side and right side.

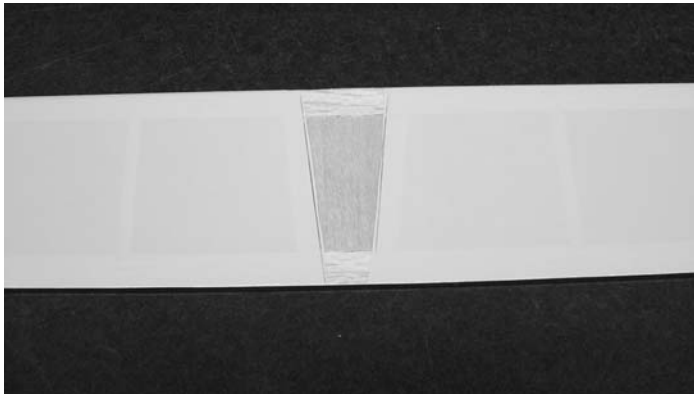

8. Carefully cut the covering 1/8" inside the line you marked and remove. Don't cut into the wood as this will weaken the structure. Remove covering both top and bottom.

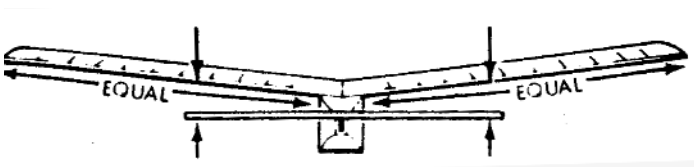

- Look down the length of the fuselage and check that the stabilizer is parallel to the wing. If it is not then shim the low side till they are parallel.
- When satisfied then glue the stabilizer in place using 5 minuet epoxy. Make sure the stabilizer remains both perpendicular and parallel to the wing and fuselage while the epoxy dries.

Elevator Installation

1. Collect the following parts:
- (1) Fuselage With Stabilizer
 - (2) Elevators
 - (6) Mini CA Hinges
 - (2) Plastic elevator joiners 3/8" x 1"
 - (1) nylon control horn

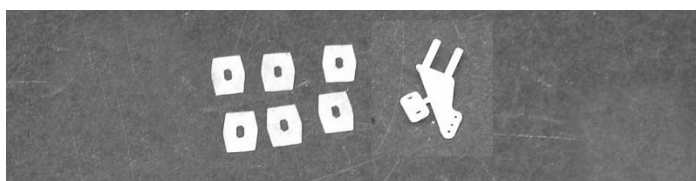
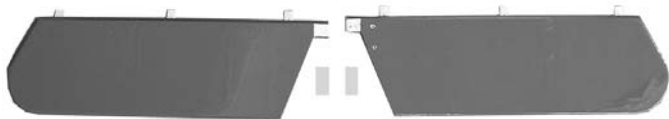

2. Locate the pre-drilled control hole holes in the right side elevator. .
- Place glue on the control horn pins and insert them in the holes.
 - Install the plate on the pins on the top side and glue.

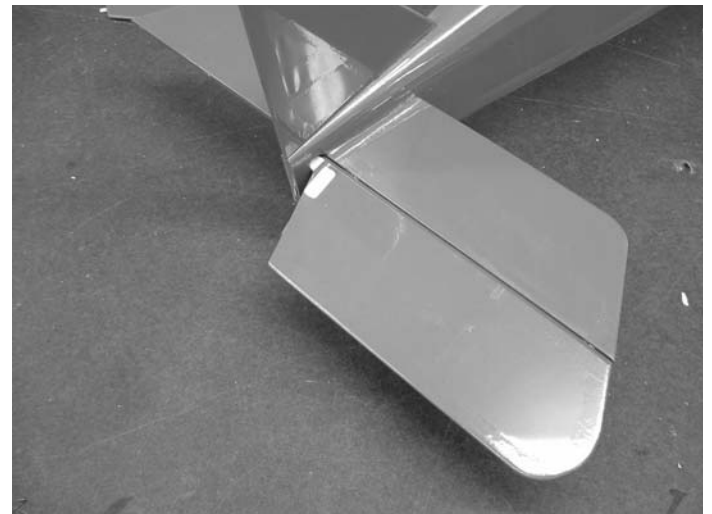

3. Insert 3 hinges half way into each elevator
- Slide the elevator hinges into the stabilizer.
4. Make sure the elevator is pushed up tight against the stabilizer and the end of the elevator is even with the end of the stabilizer.



5. Deflect the elevator to its full travel (about 1") and glue the hinges in place using thin CA
 - Turn the plane over and repeat for the bottom side.
6. Repeat steps 3,4, and 5 for the left elevator.

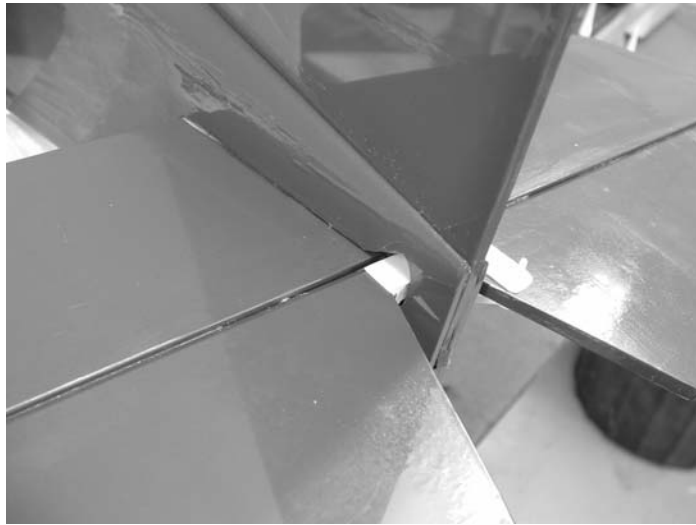

7. Join the two elevator halves in the center using the 3/8" x 1" strips of plastic. Glue one on the top of the elevators where they meet in the center and one on the bottom side.

Fin & Rudder Installation

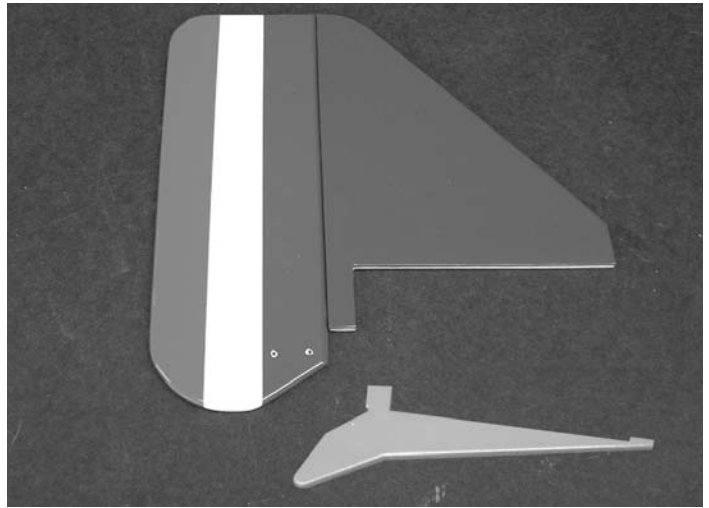

1. Collect the following parts:
 - (1) Fuselage With Stabilizer
 - (2) Fin & Rudder
 - (2) Mini CA Hinges
 - (1) Nylon Control Horn
 - (1) Tail skid

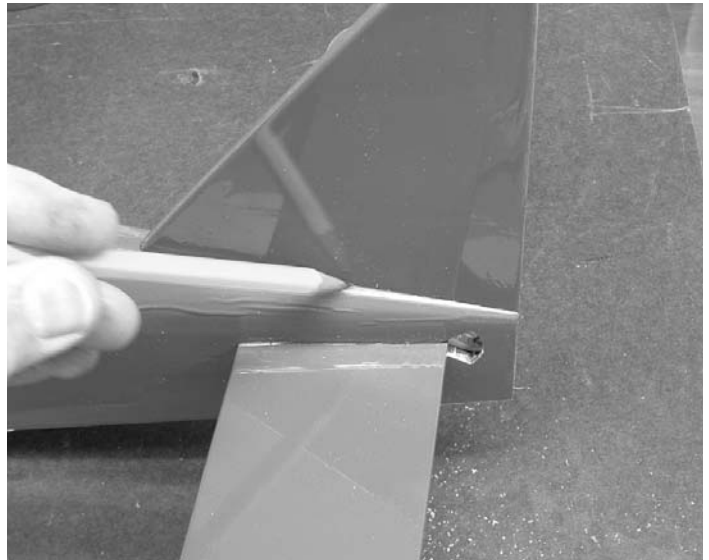

2. Fit the fin into the notch on the top of the fuselage and mark around the top edge of the fuselage.

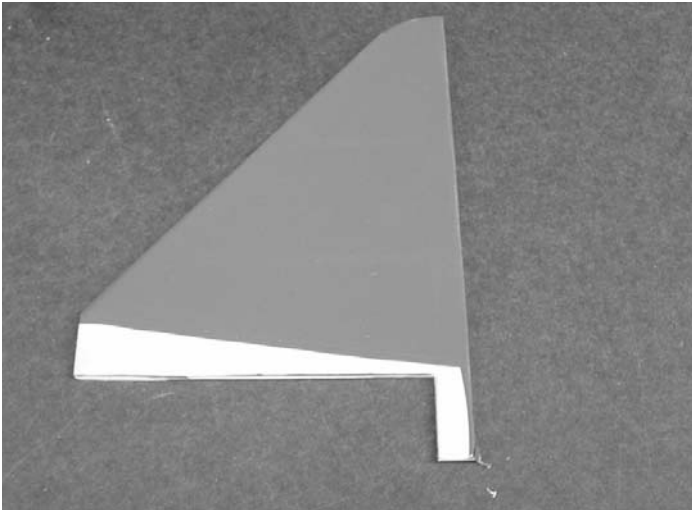

3. Remove the covering by cutting 1/8" inside the line you marked making sure not to cut into the wood.
- Glue the fin into the fuselage using epoxy.



5. Fit the hinges into place on the fin and make sure the rudder is tight against the fin. Deflect the rudder to one side about 1-1/2" and glue hinges with thin CA.
- Deflect the rudder in the other direction and glue the hinges on the opposite side.

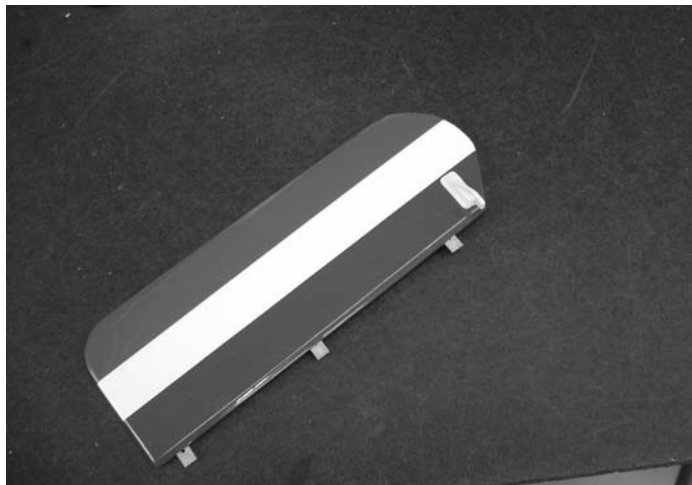

4. Place a drop of glue on the control horn and insert the rudder control horn in the left side rudder holes.
- Insert the back plate onto the control horn pins sticking out the other side of the rudder.
- Place a drop of glue on the pins to hold the back plate in place.



6. Glue the tail skid into the notches provided on the bottom of the fuselage.

Pushrod Installation

1. Collect the following parts:
 - (2) Nylon swivel keepers
 - (2) 20" Long Pushrod Wire



2. Insert the pushrod into the tube in the fuselage.
 - Make a 1/4" bend at the end of the pushrod and place it in the control horn.
 - Place a swivel keeper on the end of the pushrod.

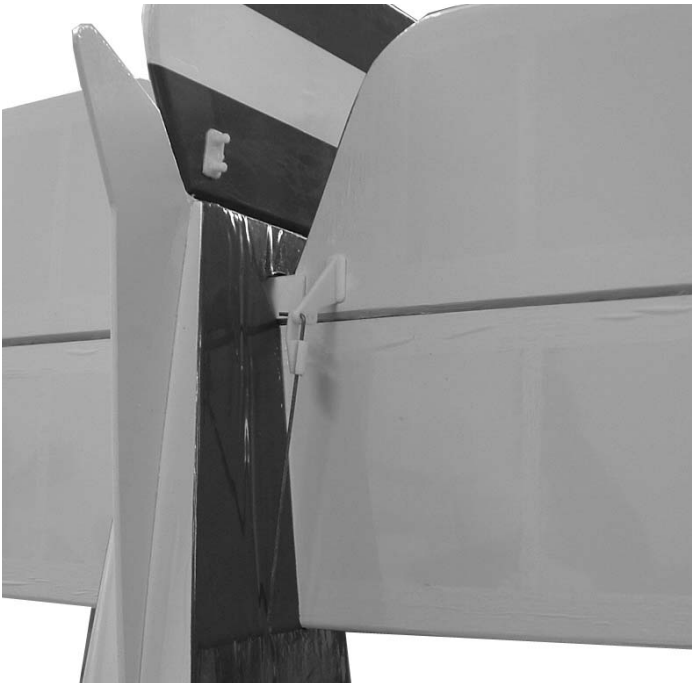

3. Repeat step 2 for the elevator pushrod and control horn.

Radio Installation

1. Collect the following parts:
 - (1) Fuselage
 - (2) Micro Servos with Hardware (Not Included)
 - (1) Micro Receiver (Not Included)
 - (1) Servo "Y" Harness (Not Included)
 - (2) Mini- Pushrod Connectors

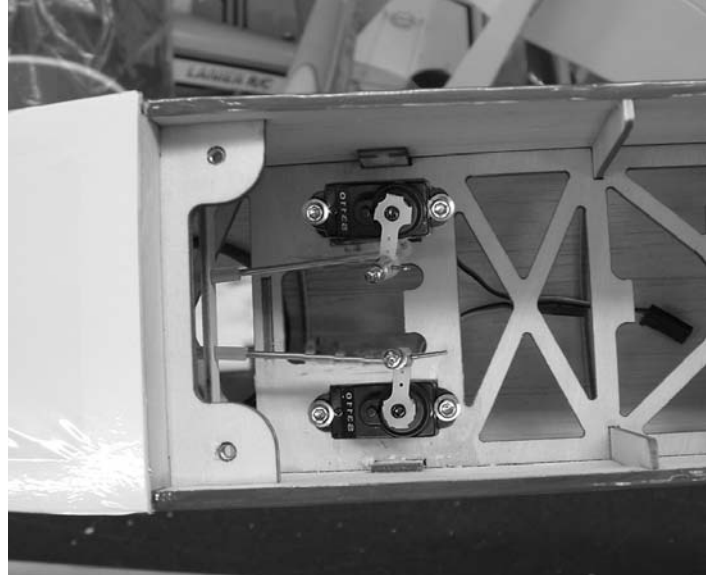

2. Mount the elevator and rudder servo as shown above.
 - Attach the EZ connectors to the servo arms the same way you did the aileron servos.
 - Insert the pushrod wires through the EZ connectors and mount the two servo arms to the top of the servos.
 - Cut off the excess pushrod wire.
3. Plug the elevator and rudder servos into your receiver.
 - Attach the "Y" harness to the receiver in the aileron channel.
 - Plug in the speed control.
 - Cut foam and wrap around the receiver.
4. Put the receiver wrapped in foam in front of the servos.

Top Wing Installation

1. Collect the following parts:
 - (2) Cabane struts
 - (2) N- struts
 - (16) #2 x 3/8" screws

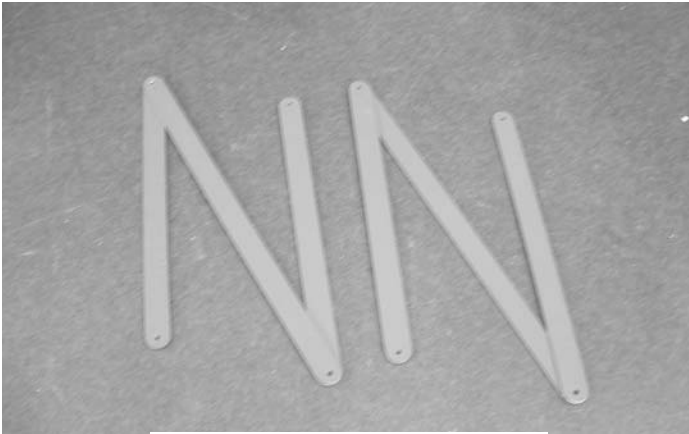

N-Struts

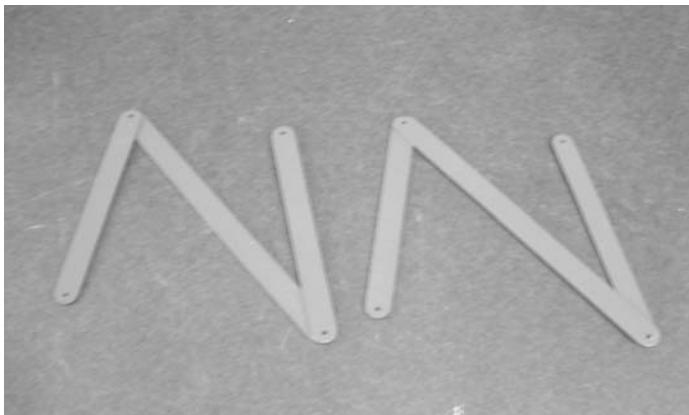

Cabane Struts

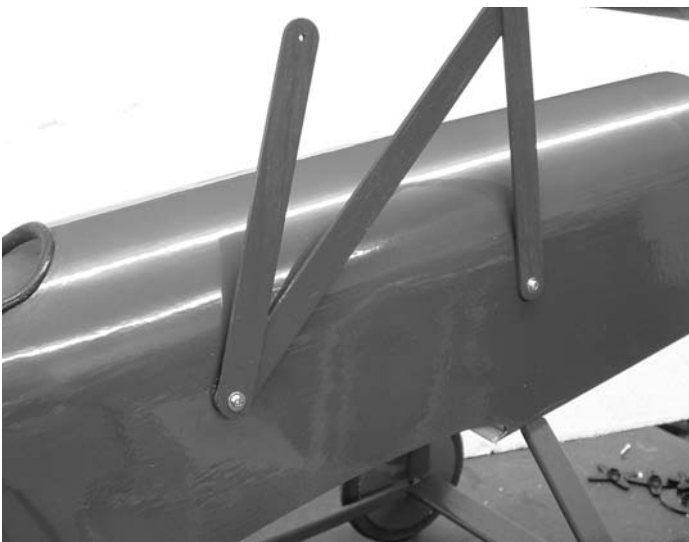

2. Attach the cabane struts to the fuselage side as shown above. Use the pre-drilled holes in the fuselage side to locate them.

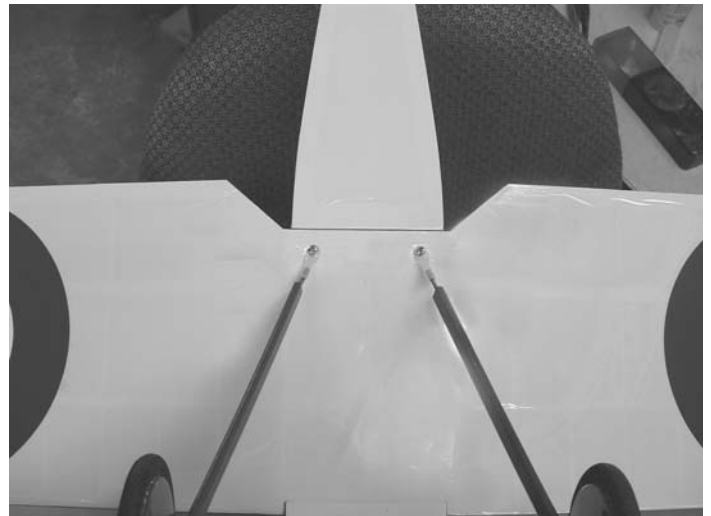

3. Bolt the bottom wing in place with the landing gear struts under the wing bolts.



4. Set the top wing in place on the cabane struts and install the four screws.



5. Install the N-struts and secure with four screws.

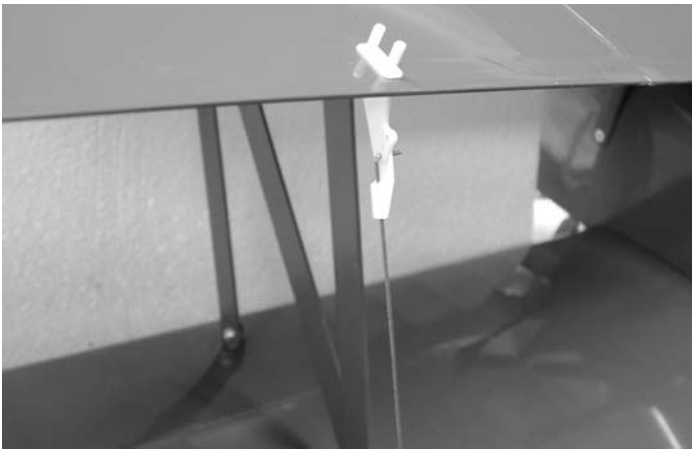

6. Locate the 1/32" x 7" aileron pushrod and make a 90 degree bend 1/4" long in one end. Fit it into the outer hole on the top aileron control horn and retain with the swivel keeper.

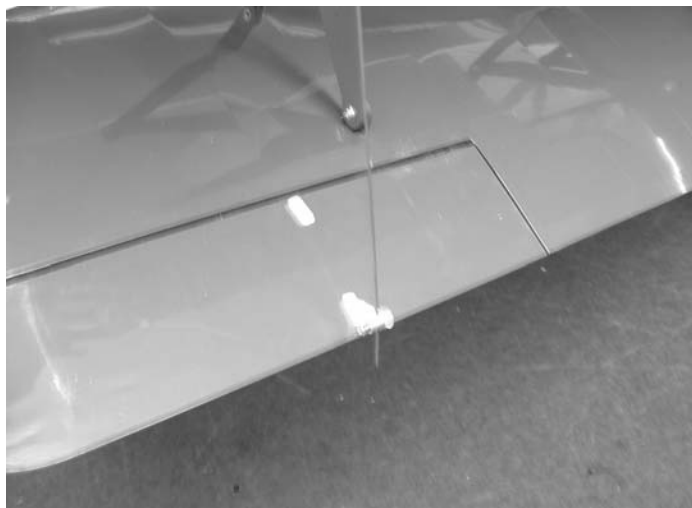

7. Fit the bottom end of the pushrod into the e-z connector on the bottom wing aileron.
- Center both ailerons and tighten the set screw.

Installing Motor & ESC

1. Collect the following parts:
- (1) Fuselage
 - (1) Motor (Not Included)
 - (1) Electronic Speed Control (Not Included)
 - (1) Screw for motor installation (Not Included)

Note:
 Read the instructions that come with your motor and speed control for proper wiring. Your Motor and Speed Control might be different than shown.

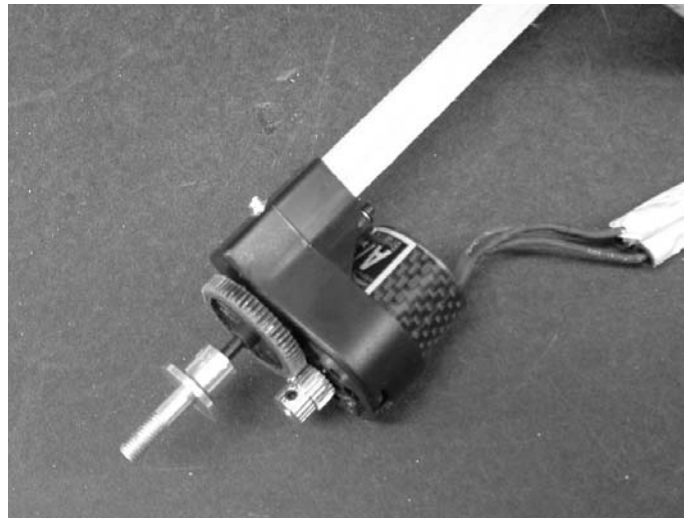

2. We used the Ultra fly A30-29 brushless motor which comes with the gear box and prop adapter. It mounts on a 3/8" square stick which is supplied with the plane. The firewall is set up to accept either the 3/8" square mount or an outrunner radial mount.



3. If using the 3/8" stick mount you will need to remove some wood below it to allow the motor wires to clear the firewall.

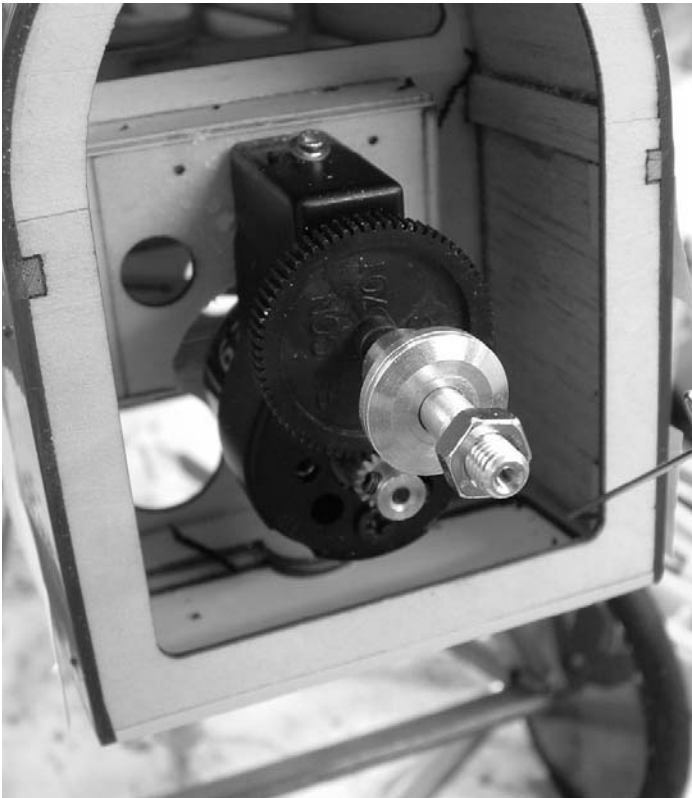

4. Glue the motor stick into the square hole in the firewall and second bulkhead.
- Insert the speed control into the nose through the wing cutout and pull the wires through the firewall. Plug the wires into the motor and slide the motor on the stick and retain with a screw.

Caution:
Do not install the propeller at this time. Electric motors can start turning at any time during radio installation. This can cause damage to the plane or bodily harm.

Note:
We flew the S.E.5a ARF with a Ultrafly brushless motor A/30/29 with 3.89 gear ratio with a 9 x 4.7 Slo-Flyer APC prop

We also used a Castle Creations Phoenix 25 brushless speed control
This motor system worked well

Caution:
Too much speed will cause flutter on the control surfaces which can cause structural failure in the airframe.
WE DO NOT WARRANTY FOR FLUTTER.

Mounting Cowl

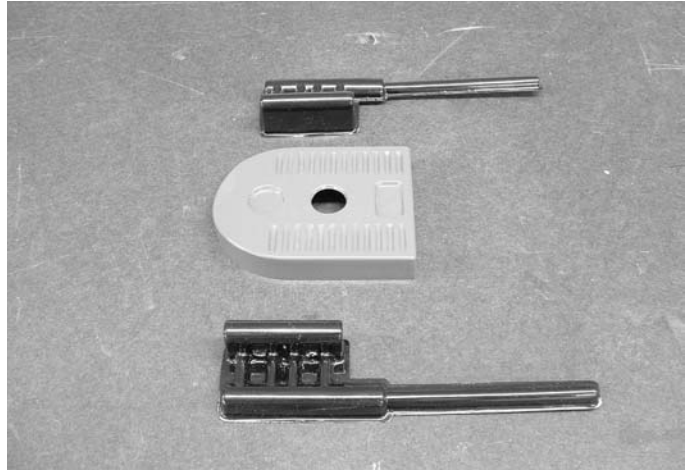

1. Collect the following parts:
 - (1) Fuselage
 - (1) Cowl and dummy engine with exhaust
 - (4) #2 x 3/8 screws

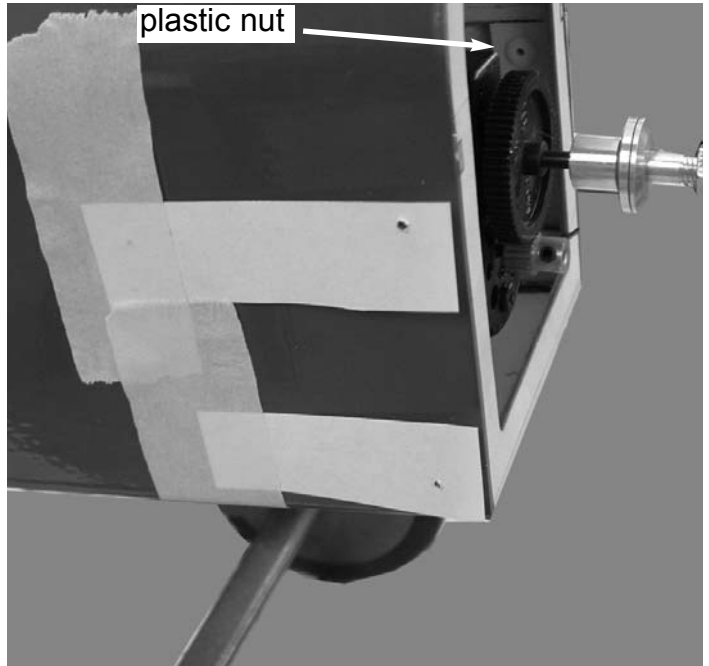

2. Locate the four plastic nuts on the inside of the fuselage on both side. Take a straight pin and bend a 90 degree angle on one end and use it to punch the holes through from the inside of the fuselage through the plastic nut.
- Cut four strips of paper about 1/2" wide and 3' long and tape to the side of the fuselage. Mark the location of the holes in the paper.



3. Slip the cowl over the nose of the plane with the paper strips on the outside of the cowl. Transfer the holes to the cowl.
- Screw the cowl in place with four #2 x 3/8" screws.



4. Using a canopy glue, glue the dummy engines in place just behind cowl and just above the mounting screws for the cowl and cabane struts. The exhaust pipe does not get glued down past the cabane strut.

Cockpit



1. Install the cockpit combing around the cockpit and glue in place.

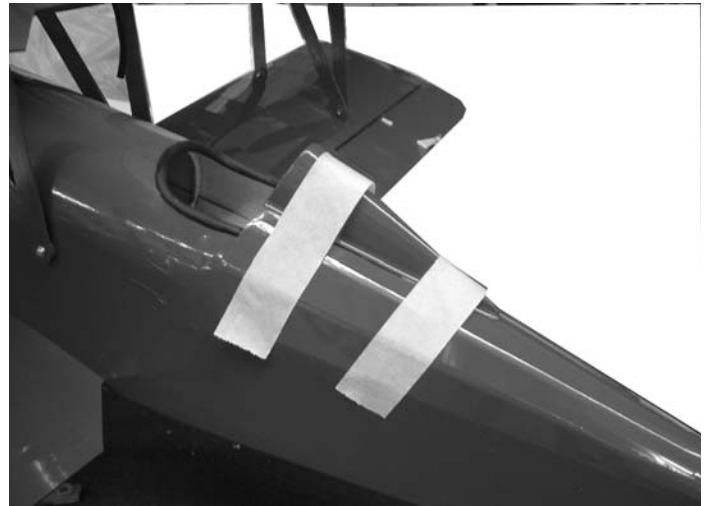

2. Glue the headrest to the top of the turtledeck and use masking tape to hold in place till the glue dries.

Decal Locations

Study the kit box label for decal location.

1. Using glass cleaner and a soft cloth, clean the model surface thoroughly before applying decal's.
- Cut the decal sheets apart in sections, as needed.
- Peel the backing off the decal and apply the decal to the location desired.

Battery Location



1. The battery will fit into the compartment on the bottom of the nose of the plane
2. We used the Electrify 1500 mah 3 cell Li-Poly battery.



- The hatch is held in place by the washer and screw in front. The washer can be rotated to remove the hatch without removing the screw.
- The covering can be removed in the open areas of the hatch to allow for cooling if necessary.



- Glue the machine gun in place on the top wing in the two notches provided.

Balancing

Balance the S.E.5a at 1" back from the leading edge of the bottom wing

Control Set Up

Turn on your transmitter and plug in the receiver battery. Center all the control surfaces (rudder, elevator & aileron). If required by your speed control this is the time to program it for your use.

Control Travel

Aileron up / down 1/2"

Elevator up / down 3/4"

Rudder right / left 1"

You will want to adjust these throws to suit your flying abilities. The throws given are starting throws.