

Heli-Max®

AXE™
100SS

AXE™
100SSL



AXE100 SS/SSL ***Instruction Manual***

NOTICE

The instruction manual, warranties and other associated documentation are subject to change without notice. Hobbico assumes no responsibility for inadvertent errors in this manual.

Heli-Max products are to be used by ages 14 and over.

Thank you for purchasing the Heli-Max AXE100 SS or SSL Helicopter. We are certain you will get many hours of enjoyment out of this model. If you should have any questions or concerns, please feel free to contact us at: helihotline@hobbico.com.

For the latest technical updates or manual corrections to the AXE100 SS/SSL visit the Heli-Max web site at www.helimax-rc.com. Open the “Helicopters” link, and then select the AXE100 SS or AXE 100SSL helicopter. If there is any new technical information, changes or important updates to this model a “tech notice” box will appear on the page. Click the “tech notice” box to learn more.



When you see this symbol, please pay special attention and heed all warnings regarding the information within.



Failure to follow these safety precautions may result in injury to yourself and others.

- Keep your face and body as well as all spectators away from the rotating plane of the blades whenever the battery is connected. Keep loose clothing, shirt sleeves, ties, scarfs, long hair or loose objects such as pencils or screwdrivers that may fall out of shirt or jacket pockets away from the rotors. The spinning blades of a model helicopter can cause serious injury. When choosing a flying site for your AXE100 SS/SSL, stay clear of buildings, trees and power lines. AVOID flying in or near crowded areas. DO NOT fly close to people or pets. Maintain a safe distance from the helicopter.
- Your AXE100 SS/SSL should not be considered a toy. Because of its performance capabilities, the AXE100 SS/SSL, if not operated correctly, could cause injury to you or spectators and damage to property.
- Do not alter or modify the model. Doing so may result in an unsafe or un-flyable model.
- When and if repairs are necessary you must correctly install all components so that the model operates properly on the ground and in the air. Please check the operation of the model before every flight to insure that all equipment is operating and that the model has remained structurally sound. Be sure to

check linkages or other connectors often and replace them if they show any signs of wear or fatigue.



Battery warnings and usage guidelines: Please read and understand the following regarding the usage of LiPo batteries.

Through the use of the included LiPo battery you have assumed all risk and responsibility regarding a LiPo battery and its use.

BATTERY WARNINGS

- ALWAYS unplug your battery from either the charger or helicopter after use. NEVER store your helicopter with the battery plugged into the helicopter.
- Do not attempt to charge your battery if it becomes swollen or hot.
- It's best to store your batteries charged and at room temperature. Storing a fully discharged battery may cause irreversible damage to the battery.
- Never disassemble, puncture or modify the battery pack in anyway.
- Never allow the battery temperature to exceed 150° F [65° C].
- If your battery begins to swell or “puff” during charge or discharge, or becomes damaged in any way, stop using it and contact Hobby Services at 217-398-0007 to learn the proper way to dispose of your battery.

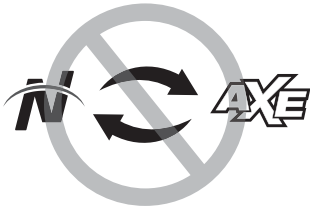

NOTE: Heli-Max AXE battery packs are **NOT** cross compatible with Heli-Max NOVUS brand products.

CHARGE WARNINGS

- Only use the included charger with the included LiPo battery. Do not attempt to use the provided charger with NiCd, NiMH or batteries with other chemistries.
- Do not leave the charger unattended while in use and always charge your battery in a fire-resistant location.
- Disconnect the battery and remove input power from the charger immediately if either becomes hot!
- Do not allow water or other foreign objects to enter the charger. Keep the charger away from moisture and do not submerge in water. Do not block the air intake holes of the charger; this could cause the charger to overheat.
- Please keep all electronic components out of the reach of children!

Heli-Max guarantees this kit to be free from defects in both material and workmanship at the date of purchase. This warranty does not cover any component parts damaged by use or modification. **In no case shall Heli-Max's liability exceed the original cost of the purchased kit.** Further, Heli-Max reserves the right to change or modify this warranty without notice. In that Heli-Max has no control over the final assembly or material used for final assembly, no liability shall be assumed nor accepted for any damage resulting from the use by the user of the final user-assembled product. By the act of using the user assembled product, the user accepts all resulting liability. **If the buyer is not prepared to accept the liability associated with the use of this product, the buyer is advised to return this kit immediately in new and unused condition to the place of purchase.**

To make a warranty claim, **Hobby Services** 217-398-0007
 send the defective part or 3002 N. Apollo Dr., Suite 1
 item to Hobby Services Champaign, IL 61822
 at this address. USA

Include a letter stating your name, return shipping address, as much contact information as possible (daytime telephone number, fax number, e-mail address), a detailed description of the problem and a photocopy of the purchase receipt. Upon receipt of the package the problem will be evaluated as quickly as possible.

- Heli-Max TX 610 Transmitter and manual
- AXE100 SS/SSL Helicopter
- 400mAh LiPo Flight Battery
- Adjustable LiPo Battery Charger with wall adaptor
- Screw Driver
- Extra Blade Set
- Extra Rotor Linkage Set



Required: 8 AA batteries

GENERAL HELICOPTER SPECIFICATIONS

Management:	Collective Pitch, 120 degree CCPM, TAGs control
Motors:	Brushless main motor, brushed tail motor
Empty Weight:	47.8g (1.69oz)
Weight RTF:	60.1g (2.12oz)
Blade Length:	105mm (4.13")
Tail Rotor Diameter:	38mm (1.5")
Overall Length:	312mm (12.3")
Height:	81mm (3.18")
Width:	52mm (2.04")
Gear Ratio:	8:1

MOTOR SPECIFICATIONS (1412 Brushless Motor)

Diameter:	14.5mm
Length:	13.6mm
Weight:	6.9g
Voltage:	3.7v
No load Current:	.7 amp
KV:	14,750

CONTROLLER SPECIFICATIONS

Max current (5min):	10 amp
Thermal protection:	90°C~120°C
Slow Start Function:	Yes
Soft cutoff:	Yes



- Please allow a 10 minute cool down period after each flight so the motor controller and motor can cool down. Failure to do so may cause loss of control due to the controller overheating and shutting down.
- Inspect the main rotor blades and blade screws before each flight for nicks or loose components. If any damage is found or if the blades have been damaged, replace the blades before flying the model again.
- The motor controller has a soft cut function that will reduce the power output to protect the flight battery. Toward the end of a flight you will notice a slight power reduction. Land the model immediately. The flight time of the AXE100 SS/SSL can be as long as 6 minutes (Standard Hover) but this will vary depending on your flying style.
- After a crash you must inspect all plastic parts on the helicopter for damage before attempting to fly the model again.
- Always unplug your battery from the helicopter after use.

RTF
READY-TO-FLY

Please fully read the transmitter manual included with your helicopter to learn more about how to use and adjust your TX610.

IMPORTANT TRANSMITTER FUNCTIONS

The Throttle Hold Switch (HOLD/FLAP) is used to disable the power output of the motor but has no effect on the other controls. The throttle hold function is intended for autorotation landings off power descent to landing; this maneuver is really not realistic with a motor driven tail. In addition to autorotation the throttle hold function can be used as a safety switch while handling the model

since it disables power to the motor. Turn the transmitter on and set the throttle hold switch to the on position. Now you can safely connect the flight battery without having to worry about inadvertently moving the throttle stick once you place the model on the ground. Verify that the idle up switch is off and the throttle stick has been moved to its lowest position. Then, simply turn the throttle hold off. The model is now ready to fly. Another use for the throttle hold function is to disable the motor before a crash without having to drop the collective stick, possibly forcing the model into the ground.



The UP-1 function is enabled and ready to use. The UP-1 switch (UP-1/GEAR) function is used for aerobatics and 3D flight. If you are a beginner to aerobatics, remember this switch sets the motor speed (see your TX610 manual for details) while still allowing positive and negative pitch control. This means if you get confused flying, pulling the throttle stick back WILL NOT decrease the power to the motor but rather add power. Hence it's a good idea to learn to use the Throttle Hold Switch when you feel a crash is imminent!

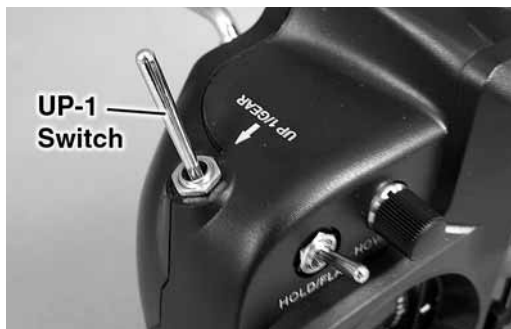

STICK CONTROLS

Throttle/Collective

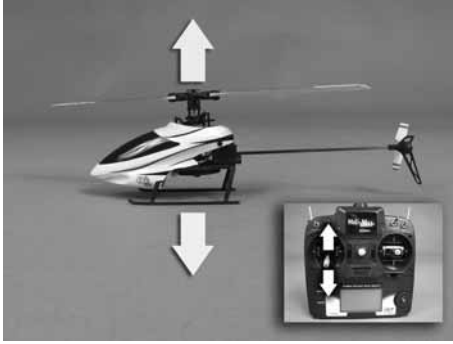

Left and right cyclic

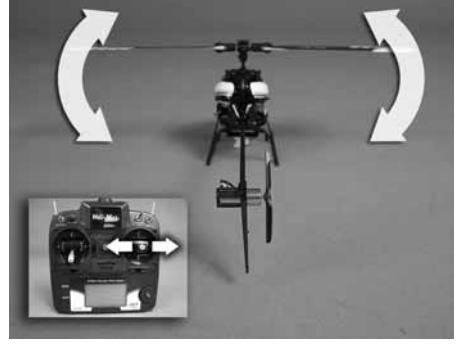

Tail (rudder)

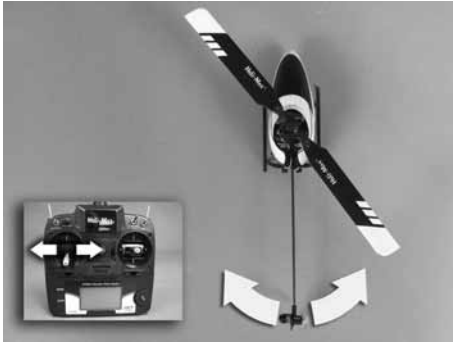

Forward and back cyclic

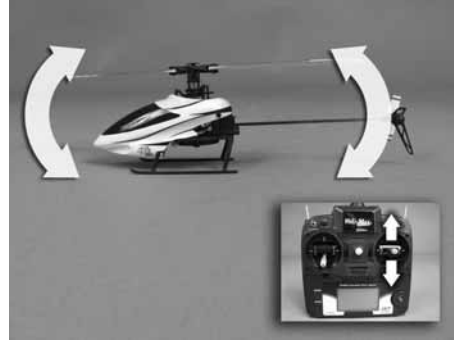

It's also important to know that your TX610 transmitter is capable of a system reset. (See how this is done in the TX610 Manual.) If you decide to do a system reset, the factory setup numbers to the Heli-Max AXE100 SS/SSL are listed here.

Below are the factory default parameters (Model Memory 8) for your AXE100 SS/SSL Helicopter.

AXE100 SS/SSL / TX610	1 AILE	2 ELEV	3 THRO	4 RUDD	5 GYRO	6 PITC
Type	HELI					
Swash Type	90 deg					
Servo Reverse (NOR/REV)	N	N	N	N	N	N
Dual Rates (D/R)	80/100	80/100		80/100		
Exponential (EXPO)	-20	-20		0		
Sub Trims (S-TRM)	0	0		0		
Normal Throttle Curve (N-TH)	0	50	75	85	100	
Normal Pitch Curve (N-PI)	45	50	55	62	68	
UP-1 Throttle Curve	HOV/FLAP.T DIAL					
UP-1 PITCH Curve	30	40	52	60	70	
Gyro Rate (G-S)	75 (Switch Down) 24 (Switch Up)					

INSTALL BATTERIES IN THE TRANSMITTER

Remove the battery cover from the back of the transmitter and install eight “AA” batteries into the transmitter. Double-check the polarity of each battery before replacing the battery cover.

**CHARGE THE FLIGHT BATTERY**

Plug the wall power supply into any 110V standard outlet. Plug the remaining 4mm plug into the side of the charger box.



The center front panel LED will light letting you know the charger has power. Plug the helicopter's power battery into the open connector of the charger. The charger will beep twice letting you know the battery is connected.

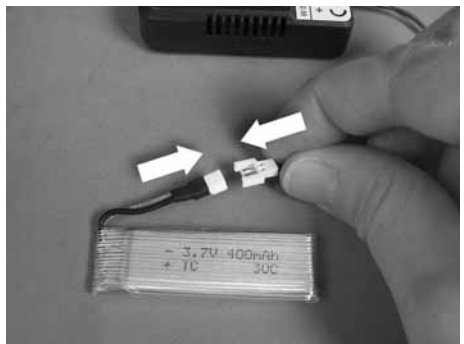

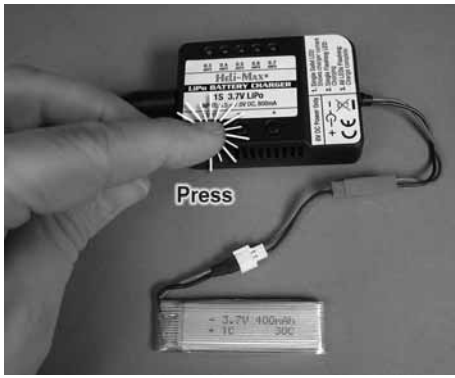

At this point you can select a slower or faster charge rate by pressing the - or + buttons located on the face of the charger. While the LED is illuminated you will need to press the charge button. You will hear 3 beeps and the charge cycle will begin.

When charging is complete, all the LEDs will flash and you will hear a steady set of beeps coming from the unit. Unplug the flight battery. It is now ready to use.

NOTE: Your battery charger ranges from .3AMPS to .7AMPS in .1 amp increments. The higher this value, the faster the battery will charge. We recommend charging on the .5AMP setting (Default).

TURN THE TRANSMITTER ON

Verify that the HOLD/FLAP and UP-1/GEAR functions are off and slide the power switch up to turn the transmitter on. If the transmitter is turned on with the HOLD/FLAP, UP-1/GEAR or throttle stick forward, the screen will show "3D" or "T-H" and a warning will sound. Turn the HOLD/FLAP and UP-1/GEAR functions off and move the throttle stick to the low position to continue. Now is a good time to make sure the electronic trim buttons on the transmitter are centered. We do not need to use them as the Incredible Heli-Max TAGS™ system controls all flight center trims.

INSTALL THE FLIGHT BATTERY

Slide the battery into the helicopter. Make sure the battery is slid all the way to the front of the battery tray.



Make sure the battery wires don't come in contact with any of the rotating parts.



Once the flight battery has been connected, always handle the helicopter as if it has full power available. The helicopter must remain still for the gyro to initialize properly. This process is instantaneous after the helicopter is held still. Turning off the HOLD/FLAP switch the helicopter is ready to go. Now is a good time to turn on the HOLD/FLAP switch until you are ready to start flying.



Your AXE100 SS/SSL uses the Tactic SLT™ protocol. This means, with the simple addition of the Tactic Anylink™ to your favorite transmitter, you can enjoy your Heli-Max AXE100 SS/SSL with a familiar transmitter, “YOURS”. After the purchase of your Anylink, make sure to fully read the instructions so you understand how to properly and safely use the Anylink system.



When using the Anylink you must make sure to follow the proper mapping procedure for your radio system. Failing to do so could cause an unsafe condition. How to map your transmitter, as well as a list of compatible transmitters, is included with your Anylink. You can find this and more information on the Tactic website, www.tacticrc.com



Your AXE100 SS/SSL RTF comes with the transmitter pre-linked to the helicopter. The Tx-R version requires you to complete this using your transmitter and an Anylink. Also, if you need to link or re-link for any reason, here is the proper procedure to do so.

To identify if your transmitter is linked to the helicopter, first turn your transmitter on, remove the canopy (see removing the canopy in the maintenance section of this manual), and view the LED closest to the link button. It should remain steady on. If it does not and is flashing your transmitter is not linked to the helicopter. To link the transmitter to the helicopter follow the below procedure.

1. Turn on the transmitter, making sure all the switches are in the back position and the throttle is down.
2. Remove the canopy from the helicopter and locate the small black button near the front of the PC board. Next to it will be an LED (flashing if not linked).
3. Place the transmitter in close proximity to the helicopter (1 to 2 feet away).
4. Press and hold the push button for 3 seconds or until the LED remains on.

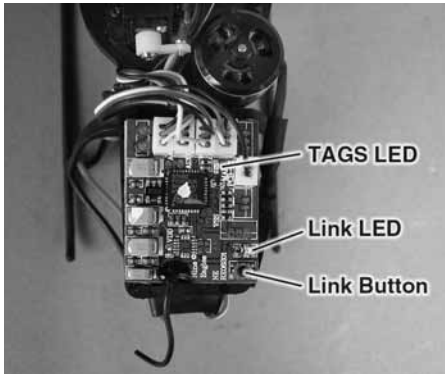

5. Monitor the flashing LED. When it stays on without flashing, your transmitter is now linked to the helicopter. Note: there is a second LED in the center of the PCB. When your transmitter is linked and the helicopter held still this LED will flicker, letting you know your TAGS™ stabilization system is working and ready.

TRANSMITTER SETUP GUIDELINES TO HELP YOU GET STARTED

FUTABA: You will find that regardless of the Futaba system you choose, the basic setup is the same. This includes the Futaba 6EX, 7C, T6J, TJ8 as well as others. We have listed the setup of a Futaba T6J transmitter. It's also worth noting that even though the AXE100 SS/SSL uses 120 degree CCPM (Cyclic-collective-pitch-mixing), with the Heli-Max TAGS system you must select the 90 degree swash arrangement. In a Futaba system this is called H-1 or 1-S under swash type.

The setups listed are will get you going and might suit your flying style. If not please feel free to make adjustments to suite your flying style.

AXE 100SS/SSL Futaba TJ6	1 AILE	2 ELEV	3 THRO	4 RUDD	5 GYRO	6 PITCH
Parameter (PARA)	HELI					
Reverse (REVR)	N	N	R	N	N	N
Dual Rates (D/R)	100/80	100/80		140/100		
Exponential (EXPO)	-10	-10		0		
Normal Throttle (N-TH)	0	40	65	80	100	
Normal Pitch (N-PI)	42	50	56	66	72	
Idle Up Throttle (I-TH)	100	95	90	95	100	
Idle Up Pitch (I-PI)	35	45	56	66	72	
Throttle Hold (HOLD)	ON 0%					
Gyro Mixing (GYRO)	ON	SW A	Pos 55	Pos 55		
Swashplate Type (SWSH)	H-1					
Timer (TIMR)	5min					

We have also included a basic setup for Spektrum™ users as well.

AXE 100 SS/SSL / Spek DX6i	AILE Low 1	ELEV 2	THRO 3	RUDD 4	GYRO 5 High	PITC 6
Type	HELI					
Reverse	R	R	N	R	N	N
Dual Rates (D/R)	100/80	100/80		100/100		
Exponential (EXPO)	Pos 20	Pos 20		0		
Travel Adjustment	100%	100%	100%	100%	100%	100%
Norm Throttle	0	50	75	85	100	
Norm Pitch	42	50	56	66	70	
Stunt Throttle	100	95	90	95	100	
Stunt Pitch	35	45	56	66	70	
Throttle Hold	ON 0%					
Hold Pitch	NULL					
Gyro Mixing	70 switch up, 75 switch down					
Swashplate Type	90deg					
Timer	5min					

This is a good setup for the Tactic 650

AXE100SS/SSL / Tactic 650	1 AILE	2 ELEV	3 THRO	4 RUDD	5 GYRO	6 PITC
Type	HELI					
Swash Type	1 Servo					
Servo Set	Servo Rev	N	N	R	N	N
	Travel	100	100	H+125	100	100
	Sub Trim	0	0	0	0	0
Dual Rate	100/80	100/80		100/100		
Expo	-20/-20	-20/-20		0/0		
TH Cut	Factory					
TH Hold	Factory					
TH Curve Normal	0	NULL	NULL	NULL	100	
TH Curve UP-1	100	NULL	NULL	NULL	100	
PI Curve Normal	-30	NULL	0%	NULL	+68	
PI Curve UP-1	-68	NULL	NULL	NULL	+68	
Gyro	+75 / +60					
Throttle Mix	NULL					
Rev Mix	NULL					
Swash Ring	110					
Program Mix	NULL					
Timer	5:00 Min					

Takeoff: During your first flights it is important to have light winds. Also, if you are flying from grass, place a rubber mat or pad down on the grass so the small rotating parts don't get hung up.

Turn off the hold switch and very slowly add power and observe the model. During "spool up" it is important to note that the torque of the main blades can cause the helicopter to rotate slightly clockwise. This is normal.

Your AXE 100 SS/SSL has the incredible Heli-Max TAGS system. The TAGS system takes care of all center trim function the transmitter. Having said this you do not need, or want, to move or adjust the trim buttons during flight. If you notice any slight flight drifting give it some time. After the helicopter's swash and servo links "break-in" the drift will diminish.

Hovering: Once the helicopter is in the air simply try to keep the helicopter in one spot. This will take some practice. Remember that even a light breeze will have an effect on the stability of the helicopter, so please take your time. Be patient and wait for a calm day.

Landing: Level the helicopter into a steady hover and slowly decrease power until the helicopter settles onto the ground. You might notice as the helicopter is ready to touch down it moves around a little. This is normal as the helicopter enters ground effect. Remember to unplug the battery from the helicopter after your flight is complete.

BASIC MANEUVERS

Once you are comfortable with hovering in one place start working on orientations. By this we mean to say, hover the helicopter in all positions, nose to the right, nose to the left and the nose pointing at you (nose-in). Getting good at this fundamental discipline will allow you to progress much faster in some of the more advanced flying maneuvers.

Slow Pirouettes: Add a small amount of tail rotor (left or right) and try rotating the helicopter slightly sideways and see if you can hold it there. If you become uncomfortable you will want to bring the tail back towards you. Once you are comfortable, try moving the helicopter to the side and turning back. Then fly back to the other side in straight lines. You can try rotating the helicopter around 360°, which is called a pirouette. The helicopter can drift during this maneuver so make certain you have plenty of room when you first start practicing.

Forward Flight: Now it's time to work into basic forward flight. Just take the basic hovering maneuvers listed above and slowly fly out farther and faster and always bring the helicopter back after one pass. Practice controlled slow flight in close as well. The more time you spend practicing here, the easier things will be later on.

AEROBATICS

So you are getting comfortable in fast forward flight? Well, now it's time to slowly progress into aerobatics. Your AXE100 SS/SSL is more than capable of full aerobatic performance. Once you are in forward flight start using the idle up switch. This switch raises the rotor RPM and allows the blades to progress into negative pitch for aerobatics and inverted flight.

Chandelles: Your first step is chandelles. Fly straight across in front of you and pull up to a 45° angle. Now at the top, when the helicopter slows down to a stop, apply left or right tail rotor to bring the nose around 180° and continue back down the 45° angle. As you progress with the maneuver you can pull a greater angle than 45°, but 90° would be considered a “stall turn”.

Loops: Once you become comfortable with the chandelles and stall turns it's time to move onto the loop. The key to the loop is to enter with plenty of speed. Start pulling aft cyclic to enter the loop and as the model transitions to inverted at the top of the loop pull back on the throttle (towards negative (-) collective). This will help maintain altitude. As the model returns back to vertical add some positive (+) collective to maintain the speed. One of the most common mistakes made on loops is using too much negative (-) collective at the top.

Flips: Be certain to start with plenty of altitude. From an upright hover slowly add in full forward cyclic. As the model approaches vertical, bring the collective stick back to center. Now, as the model continues to inverted, you will need to start adding in negative (-) collective (or pull the collective stick back towards yourself). As the model transitions back to vertical, again bring the collective stick back to the middle and start adding in positive (+) collective as the model returns back to upright. It's simply a matter of timing. The most important thing is, do not throw the sticks around. This can cause the head speed to drop and may cause the tail to drift.

Inverted Hovering: Keep in mind flying a helicopter inverted is difficult but with practice it can be learned. One of the main problems is 3 out of 4 of the controls are reversed (forward/aft cyclic, collective and tail rotor). You have to mentally reverse these while flying. It will take some practice. Take the loop you learned above and just hold the inverted portion for short periods of time. As you become accustomed to the reversed controls, you will extend the time inverted. Also, make sure you have plenty of altitude for recovery if needed.

TOOLS NEEDED

- Small screwdriver (provided)
- Soldering iron

We will describe a few simple repairs that you can do to your helicopter. We will list them as “removing” with the understanding that to reassemble one just follows each step again from the bottom up. **NOTE:** It’s a good idea to keep a magnet handy to help secure the small screws. You can also use this magnet to “magnetize” your screwdriver; just rub the end of the screwdriver on the magnet for a few seconds. This works nicely to keep the screws in place on the tip of the screwdriver. **TIP:** we use a small piece of white paper over the magnet to help see the screws.

**REMOVING THE CANOPY**

Carefully pull the back edges of the canopy outward, sliding the rubber grommets off the pegs. Then slide the canopy forward.

REMOVING THE MAIN BLADES AXE SS



Using the provided screwdriver remove the main blade screw from the blade grip. Slide the blade out of the grip.

REMOVING THE MAIN BLADES AXE SSL

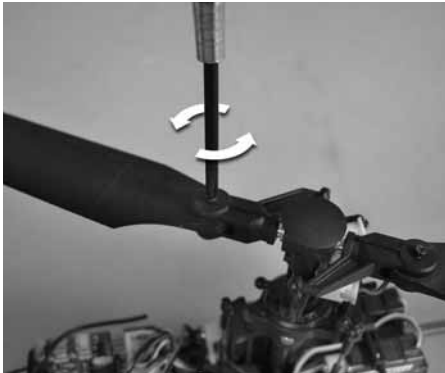

Using the supplied screwdriver remove the main blade screw from the blade grip. Carefully slide the blade from the grip and unplug the LED power wire.

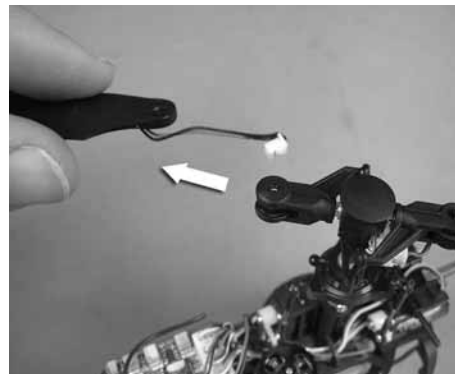

REMOVING THE TAIL BLADE



Hold the motor firmly and pry the tail blade off using your fingernail or small, flat blade screwdriver. Use your finger to press the new blade in place. **NOTE:** When reinstalling, do not force the blade tight against the motor.

REMOVING THE LANDING GEAR

A total of 6 screws hold the battery tray/landing gear in place. Using the supplied screwdriver remove the 6 screws.

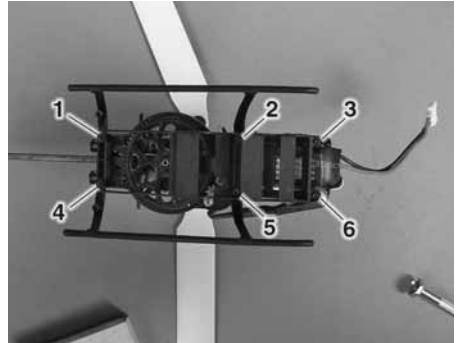

REMOVING THE MAIN GEAR AXE SS

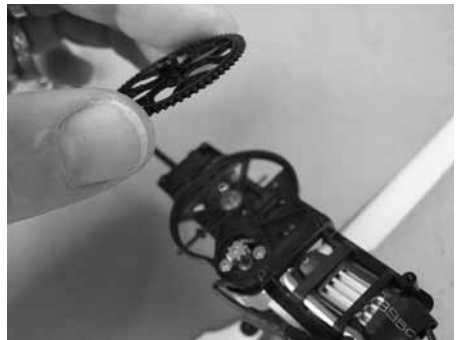

After removing the landing gear, use the supplied screwdriver to remove the screw that holds the main gear in place. Slide the main gear away.

REMOVING THE MAIN GEAR AXE SSL

After removing the landing gear, scrape away any adhesive holding the wires to the solder lugs. Unsolder the two wires from the gear contact posts. Using the supplied screwdriver, remove the screw that holds the main gear in place. Slide the main gear away, carefully snaking the two wires through the center hole.

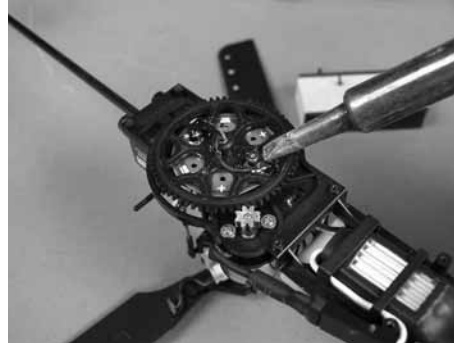

REMOVING THE MAIN SHAFT

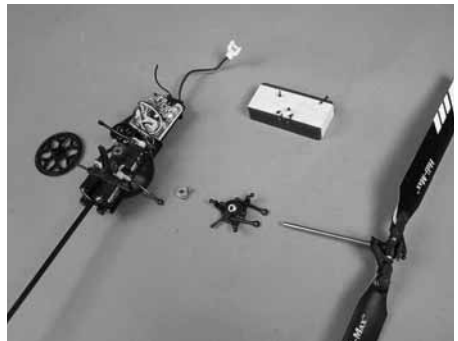

Remove the landing gear, and remove the main gear. Using the supplied screwdriver loosen the two screws on the lock collar. Remove the ball links that attach the servo pushrods to the swashplate. Remove the links from the blade grips. Slide the main shaft and head from the helicopter and remove the screw from the head block. Slide the main shaft away. **NOTE:** When reassembling, it's important to set the shaft lash using the lock collar so as not to be too loose or too tight.

REMOVING THE FEATHERING SHAFT

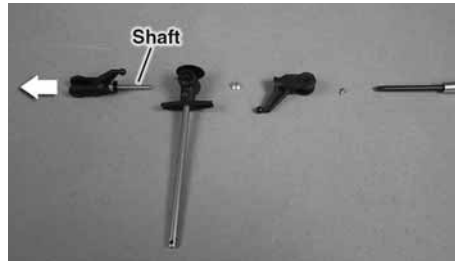
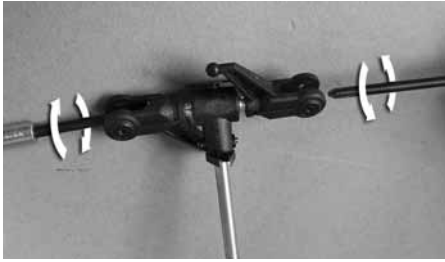

NOTE: You will have to provide a second small phillips screwdriver for this step. Remove the blades from the blade grips as described above. Place a screw driver in the end of each blade grip and engage the screws. Unscrew the screws and one of the two will remove. Slide the blade grips off, being very careful to not lose any parts. Note the direction of the silver spacer washers.

REPLACING AN AFT SERVO

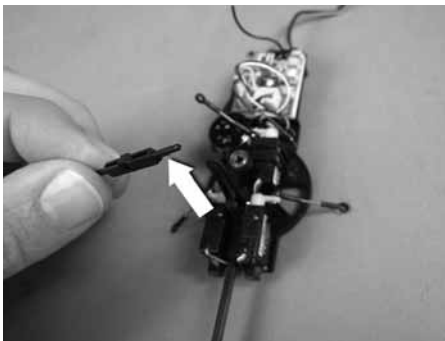
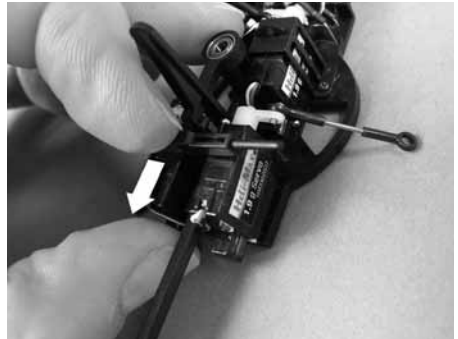
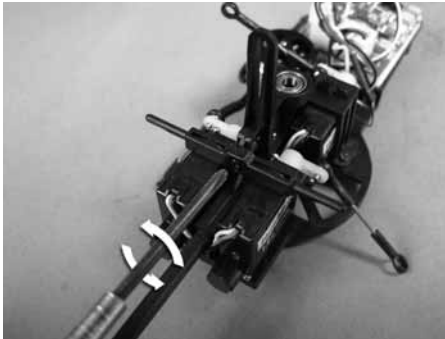

Remove the canopy. Remove the link from the swashplate. Unscrew the screw from the attachment bar. Carefully place pressure on the bar back, and then slide off the servo tabs.

Snake the wire out of the loom and then unplug the servo.

REPLACING THE FORWARD SERVO

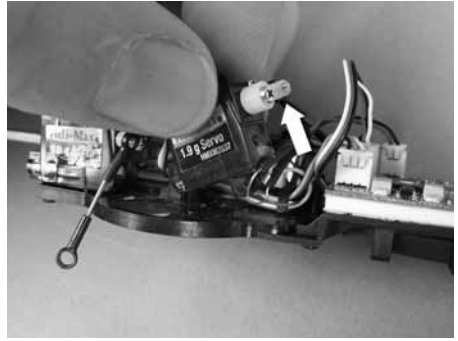
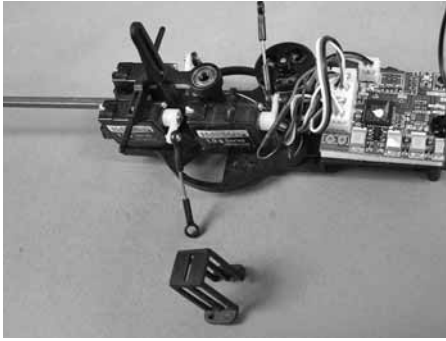

Remove the canopy. Remove the link from the swashplate. Unscrew the two screws from each side of the servo mount. Snake the wire out of the loom and then unplug the servo.

REMOVING THE TAIL BOOM

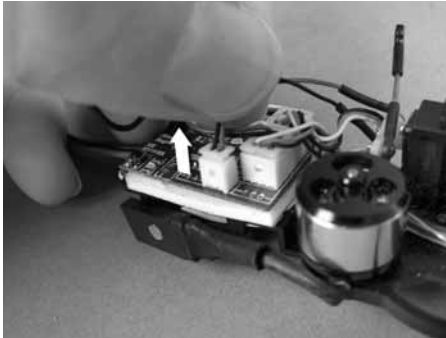

Remove the canopy. Unplug the connector leading to the tail motor. Snake the wires away from the bundle. Grasp the tail boom and pull it away from the main frame. If you find the boom hard to remove, use a drop of CA debonder on the parts and allow that to work into the joint before you try to remove it again.

Notes: _____

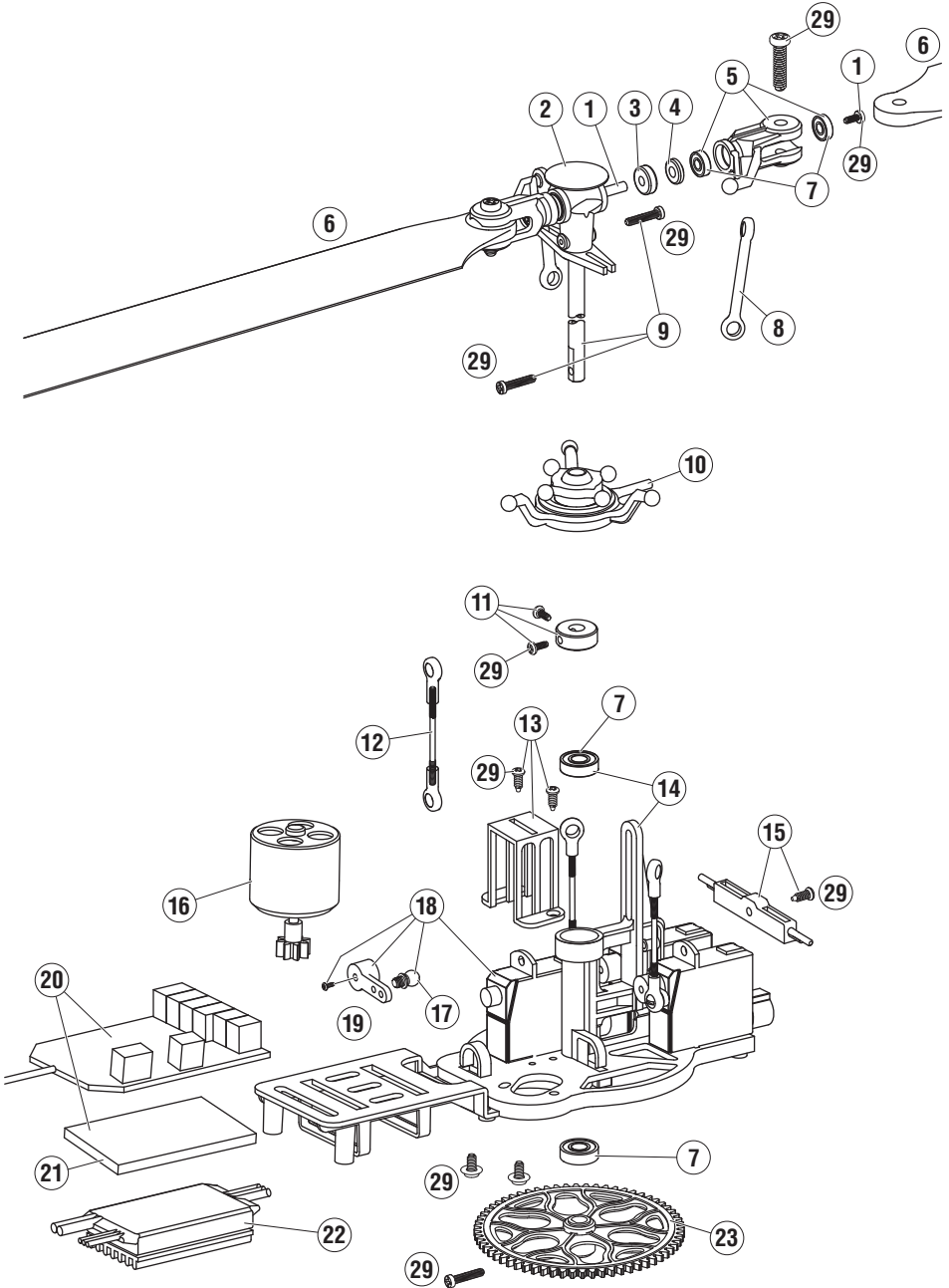

HMXE2100
Feather Shaft (2) ① ②⑨

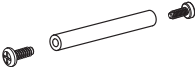

AXE100 CP/SS/SSL

HMXE2101
Head Block ②

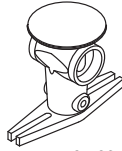

AXE100 CP/SS

HMXE2102
Rubber Dampers (6) ③



AXE100 CP/SS/SSL

HMXE2103
Blade Grip Spacers (6) ④



AXE100 CP/SS/SSL

HMXE2104
Blade Grip (2) ⑤ ⑦ ②⑨

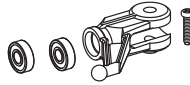

AXE100 CP/SS/SSL

HMXE2201
Main Blade (2) ⑥



AXE100 SS

HMXE2116
Bearing Set (6) ⑦



AXE100 CP/SS/SSL

HMXE2106
Head Linkage (4) ⑧



AXE100 CP/SS/SSL

HMXE2107
Main Shaft ⑨ ②⑨



AXE100 FP/MD
AXE100 CP/SS

HMXE2190
Swashplate ⑩



AXE100 SS/SSL

HMXE2109
Main Shaft Collar ⑪ ②⑨



AXE100 FP/MD
AXE100 CP/SS/SSL

HMXE2111
Servo Links (3) ⑫



AXE100 CP/SS/SSL

HMXE2117
Elevator Servo Mount ⑬ ②⑨

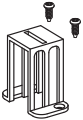

AXE100 CP/SS/SSL

HMXE2191
Main Frame ⑭ ⑦

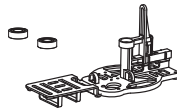

AXE100 SS/SSL

HMXE2120
Canopy Servo Mount ⑮ ②⑨

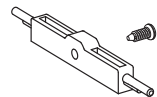

AXE100 CP/SS/SSL

HMXXG8031
Brushless Motor ⑯ ②⑨

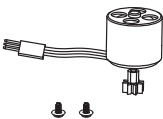

AXE100 SS/SSL

HMXE2185
Ball Link Stud (6) ⑰



AXE100 CP/SS/SSL

HMXM2037
1.9g Servo W / Arm ⑱ ⑰ ⑲

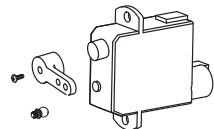

AXE100 CP/SS/SSL

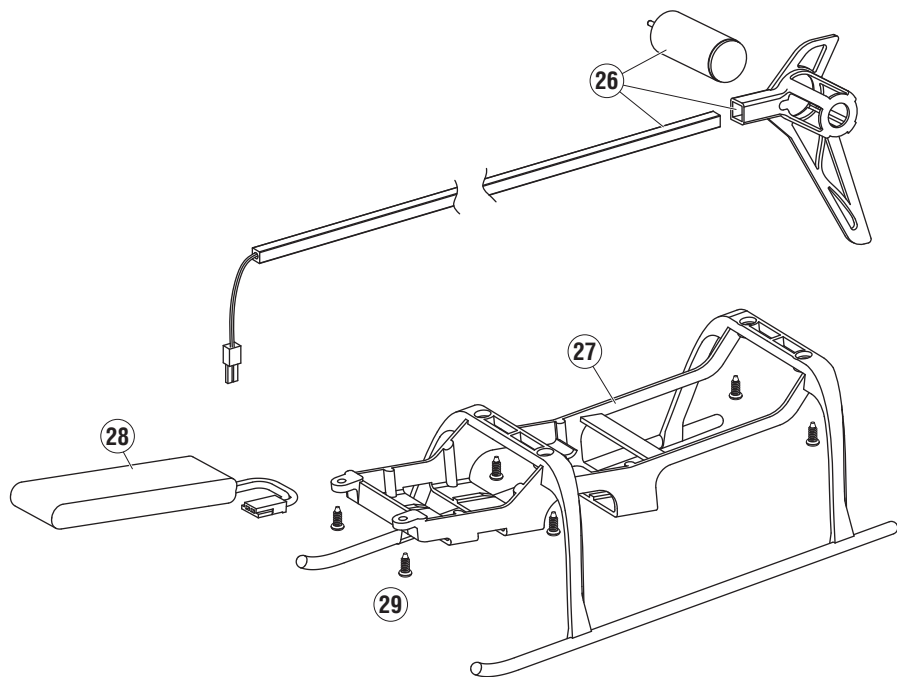
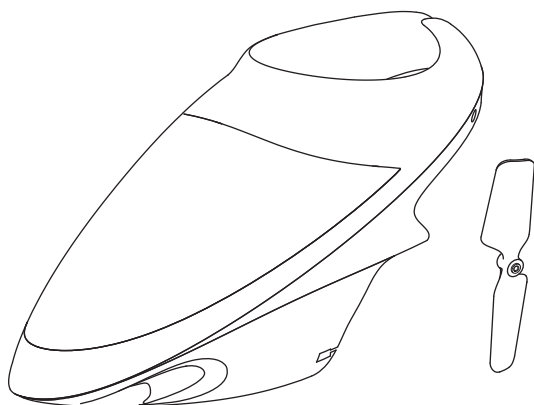

HMXE2118
Servo Arm W/ Link (3) (19) (17) (18)



AXE100 CP/SS/SSL

HMXM2042
TAGS Control Board (20) (21)

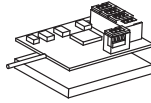

AXE100 SS

HMXE2121
Double Stick Tape (4) (21)



AXE100 CP/SS/SSL

HMXM2043
10A Control Board (22)

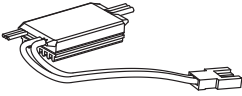

AXE100 SS/SSL

HMXE2204
Main Gear (23) (29)



AXE100 SS

HMXG8033
Tail Boom W/ Motor (26)

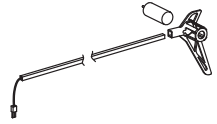

AXE100 SS

HMXE2192
Landing Skid W/ Screws (27) (29)

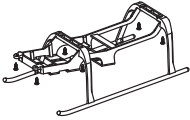

AXE100 SS/SSL

HMXP1010
400mAh Lipo Battery Pack (28)



AXE100 SS/SSL

HMXE2189
Screw Set (29)



AXE100 SS

HMXE2124
Assembled Rotor Head

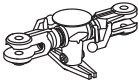

AXE100 CP/SS

HMXE2114
Canopy (Yellow)



AXE100 CP

HMXE2187
Canopy (Green)



AXE100 SS

HMXE2198
Canopy (Gold)



AXE100 SSL

HMXE2152
Tail Rotor (Black)

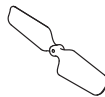

AXE100 FP

HMXE2122
Tail Rotor (Yellow)

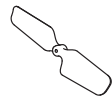

AXE100 CP

HMXE2188
Tail Rotor (Green)

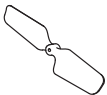

AXE100 SS

HMXE2199
Tail Rotor (Gold)

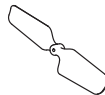

AXE100 SSL

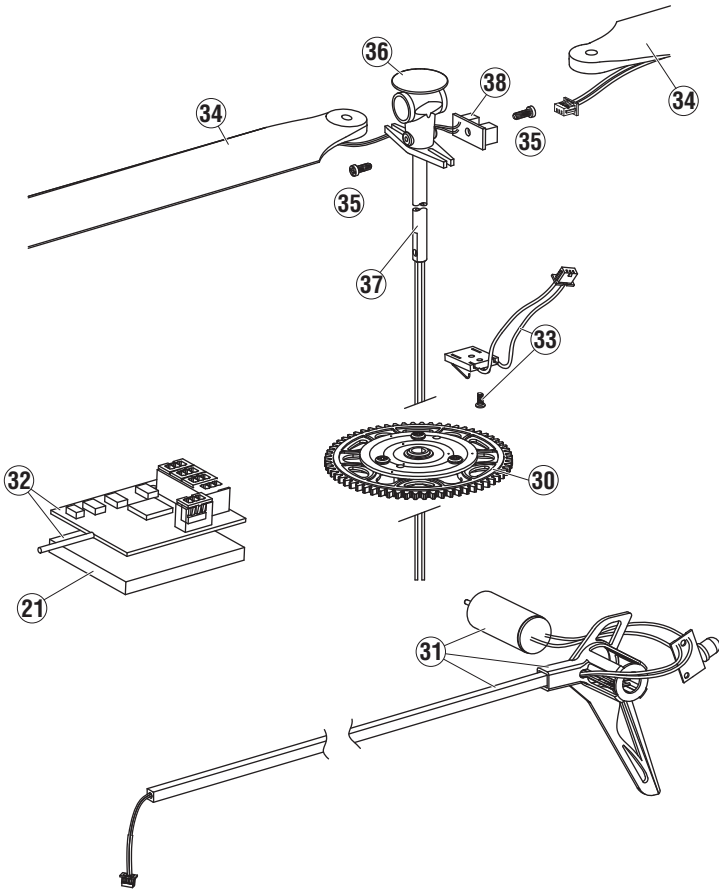

AXE100 SSL

HMXE2197
Main Gear W / Contact Plate

30



AXE100 SSL

HMXG8032
Tail Boom W / Motor and LED

31

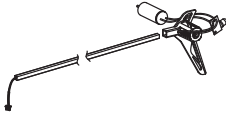

AXE100 SSL

HMXM2044
TAGS Control Board

32

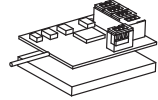

AXE100 SSL

HMXE2196
LED Plate Contacts

33

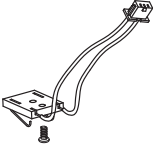

AXE100 SSL

HMXE2193
Rotor Blades W / LEDs

34

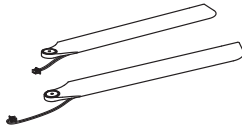

AXE100 SSL

HMXE2200
Screw Set

35



AXE100 SSL

HMXE2194
Main Shaft
w/ Rotor Head and Board

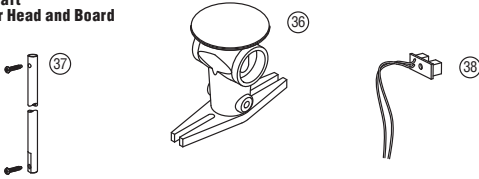

AXE100 SSL

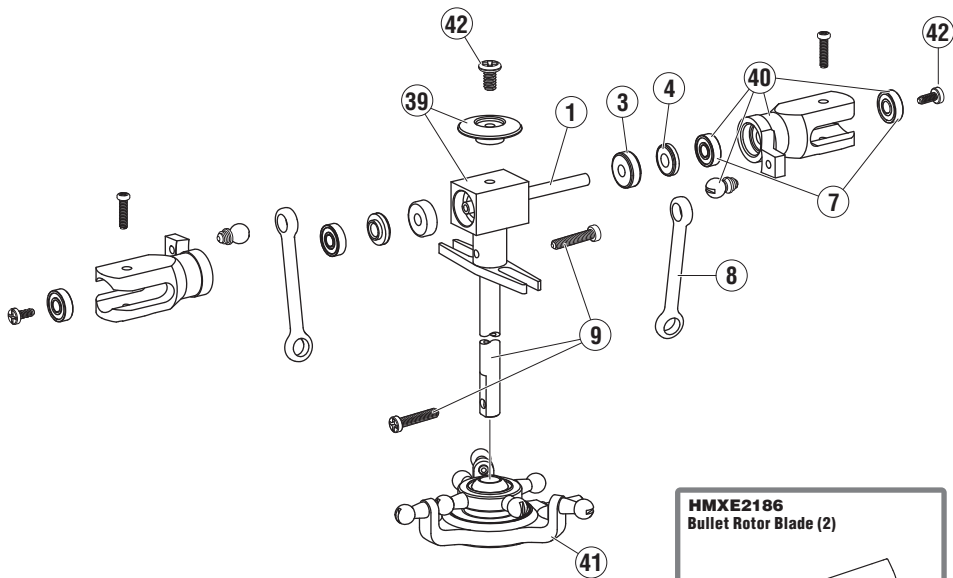

HMXE2186
Bullet Rotor Blade (2)

AXE100 ALL

HMXE2054
CNC Rotor Head (Assembled) (41)

AXE100 CP/SS/SSL

HMXE2050
CNC Metal Head Block (39)

AXE100 CP/SS/SSL

HMXE2051
CNC Metal Blade Grips (40)

AXE100 CP/SS/SSL

HMXE2052
CNC Metal Swashplate (41)

AXE100 CP/SS/SSL

HMXE2053
Screw Set CNC Rotor Head (42)

AXE100 CP/SS/SSL

HMXE2123
Battery Plug Adaptor