

Heli-Max®

AXE™ **100 FP**



Tx-R™
TRANSMITTER-READY

Axe 100 FP 2.4GHz RTF/Tx-R Instruction Manual



TABLE OF CONTENTS

INTRODUCTION	2
SAFETY PRECAUTIONS	2
WARRANTY	3
ADDITIONAL ITEMS REQUIRED	4
KIT INSPECTION	4
KIT CONTENTS	4
Tx-R	5
BATTERY PRECAUTIONS	6
CHARGING THE FLIGHT BATTERY	7
INSTALL THE TRANSMITTER BATTERIES	8
TRANSMITTER CONTROLS	8
TURNING THE MODEL ON	10
FLYING	11
ORDERING REPLACEMENT PARTS	12
PARTS LIST	13
EXPLODED VIEW	14



INTRODUCTION

Thank you for purchasing the Heli-Max Axe 100 FP Helicopter. We are certain you will get many hours of enjoyment out of this model. If you should have any questions or concerns please feel free to contact us at **helihotline@hobbico.com**. For the latest technical updates or manual corrections, visit the Heli-Max web site at:

www.helimax-rc.com

Open the “Helicopters” link, and then select the Axe 100 FP. If there is new technical information or changes to this model a “tech notice” box will appear in the upper left corner of the page.



SAFETY PRECAUTIONS

Follow these safety precautions when operating this or any model helicopter.

- Keep your face and body as well as all spectators away from the plane of rotation of the rotors whenever the battery is connected.
- Keep these items away from the rotors: loose clothing, shirt sleeves, ties, scarfs, long hair or loose objects such as pencils or screwdrivers that may fall out of shirt or jacket pockets into the rotors.

- The spinning blades of a model helicopter can cause serious injury. When choosing a flying site for your Axe 100 FP, stay clear of buildings, trees and power lines. AVOID flying in or near crowded areas. DO NOT fly close to people, children or pets.
- Maintain a safe pilot-to-helicopter distance while flying.
- Your Axe 100 FP should not be considered a toy, but rather a sophisticated, working model that functions very much like a full-size helicopter. Because of its performance capabilities, the Axe 100 FP, if not operated correctly, could possibly cause injury to yourself or spectators and damage to property.
- Do not alter or modify the model, as doing so may result in an unsafe or unflyable model.
- You must check the operation of the model before **every** flight to insure that all equipment is operating and that the model has remained structurally sound. Be sure to check linkages or other connectors often and replace them if they show any signs of wear or fatigue.



Heli-Max® guarantees this kit to be free from defects in both material and workmanship at the date of purchase. This warranty does not cover any component parts damaged by use or modification. **In no case shall Heli-Max's liability exceed the original cost of the purchased kit.** Further, Heli-Max reserves the right to change or modify this warranty without notice.

In that Heli-Max has no control over the final assembly or material used for final assembly, no liability shall be assumed nor accepted for any damage resulting from the use by the user of the final user-assembled product. By the act of using the user-assembled product, the user accepts all resulting liability.

If the buyer is not prepared to accept the liability associated with the use of this product, the buyer is advised to return this kit immediately in new and unused condition to the place of purchase.

To make a warranty claim, send the defective part or item to Hobby Services at this address.

Hobby Services
3002 N. Apollo Dr., Suite 1
Champaign, IL 61822
USA

Include a letter stating your name, return shipping address, as much contact information as possible (daytime telephone number, fax number, e-mail address), a detailed description of the problem and a photocopy of the purchase receipt. Upon receipt of the package the problem will be evaluated as quickly as possible.

READ THROUGH THIS MANUAL BEFORE STARTING CONSTRUCTION. IT CONTAINS IMPORTANT INSTRUCTIONS AND WARNINGS CONCERNING THE ASSEMBLY AND USE OF THIS MODEL.

Heli-Max[®] **ADDITIONAL ITEMS REQUIRED**

- For Tx-R: Tactic AnyLink and your transmitter

Heli-Max[®] **KIT INSPECTION**

Before starting assembly, take an inventory of the Axe 100 FP kit. If any parts are missing, damaged, or defective, contact Product Support. When reporting defective or missing parts, use the part names exactly as they are written in the **Kit Contents** list.

Heli-Max Product Support
3002 N. Apollo Drive, Suite 1
Champaign, IL 61822

Ph: (217) 398-8970, ext. 5
Fax: (217) 398-7721
E-mail: helihotline@hobbico.com

Heli-Max[®] **KIT CONTENTS**

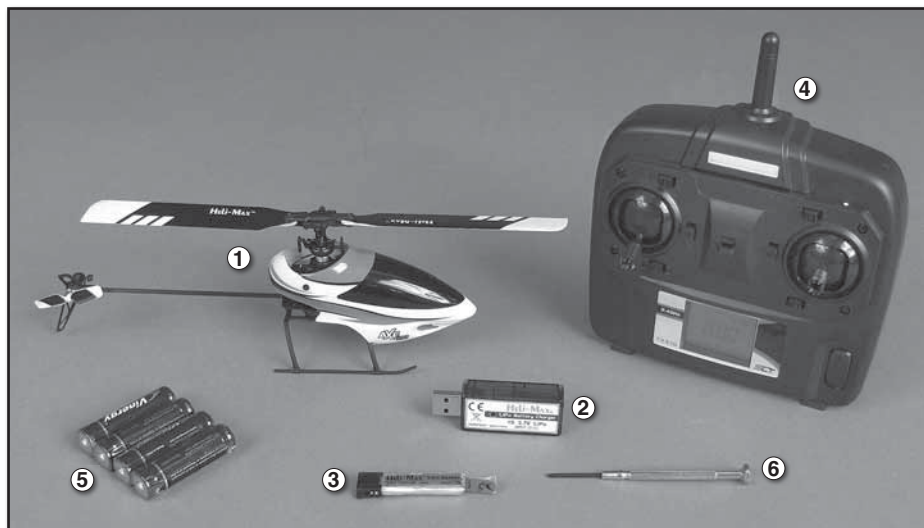

- | | | |
|----------------|---------------------------|---------------------|
| 1. Helicopter | 3. Flight Battery | 5. AA Batteries (4) |
| 2. USB Charger | 4. Transmitter (RTF only) | 6. Screwdriver |



Your new Axe 100 FP uses SLT protocol. This means that with the simple addition of the Tactic Anylink™, you can enjoy your new machine with nearly “any” transmitter.

AnyLink Tx Compatibility Chart		(Check Tx-ready.com for updates)	Required Cable
Futaba®	4YF (72MHz), 4YBF, 6EX, 6J, 7C, 8FG, 9C, 10C, 12FG		INCLUDED
	4VF, 5U, 6A, 6DA, 6H, 6YF, 6YG, 7NFK, 8U, 9Z		TACM0003
	4YF (2.4 GHz), 12Z, 14MZ, 18MZ		TACM0007*
Hitec®	Neon, Flash (4sx, 5, 5sx), Focus (4, 6), Laser (4, 6), Optic 5 (72MHz), Optic 6 (72MHz, 2.4GHz), Eclipse 7 (72MHz), Prism (7, 7X)		TACM0003
	Aurora 9		TACM0004
	Optic 5 (2.4GHz), Optic 6 Sport, Eclipse 7 (2.4GHz)		TACM0005*
JR®	All aircraft transmitters with trainer jack		INCLUDED
Spektrum®	DX6, DX6i, DX7		INCLUDED
	DX4e, DX5e, DX7s, DX8, DX10t, DX18		TACM0005*
Tower Hobbies®	4TH, 6XM		INCLUDED
	4FM, 6FM		TACM0003
Graupner®	MX-16		INCLUDED

*Includes a rechargeable 6.6V LiFe battery. LiFe-compatible charger required.



WARNING: AnyLink must be in Normal Mapping (1 Beep) when Futaba or Hitec transmitters are used with Tx-R aircraft. If using Spektrum, JR, or Graupner transmitters, AnyLink must be in Alternate Mapping (2 Beeps). (See AnyLink manual.)

This helicopter is unique in that it can work with either an airplane or helicopter radio. Use the following guide as a setup. Once you feel comfortable, fine tune to your liking.

Setup Note: Only adjust the listed parameters and keep all other airplane or helicopter functions inhibited. If you fly in heli mode, make sure your swash is setup for a 90 deg system (H-1).

	channel 1	channel 2	channel 3	channel 4
Futaba®	Reverse	N	N	R
	Endpoint	140* each way	140* each way	
	D/R	100/80	100/80	100
	Expo	pos 20	pos 20	0
Spektrum®	Reverse	N	N	R
	Endpoint	140* each way	140* each way	
	D/R	100/80	100/80	100
	Expo	neg 20	neg 20	0

*or as high as you can go

Spektrum is a registered trademark of Horizon Hobby, Inc.

This Axe 100 FP uses a lithium polymer (LiPo) battery. Follow these precautions to insure safe and trouble free operation.

- Only use the included charger with the included battery.
- Do not attempt to use this charger with NiCd or NiMH battery packs.
- If the battery should become damaged, discard it. Do not attempt to use a damaged battery.
- Do not leave the charger unattended while charging. Disconnect the battery and unplug the charger immediately if either becomes hot! However, it is normal for the charger to get warm.
- Disconnect the battery from the charger and carefully move the battery to a fireproof location if the battery begins to swell or smoke!
- Never trickle charge.
- Never allow the battery temperature to exceed 140° F [60° C].
- Never disassemble or modify pack wiring in any way or puncture cells.
- Do not allow water, moisture or foreign objects into the charger.
- Do not place the charger or any battery on a flammable surface or near a combustible material while in use.
- Do not charge on a carpet, cluttered workbench, paper, plastic, vinyl, leather, wood, or inside an R/C model.
- Never charge inside a vehicle.
- Always disconnect the battery and remove the charger from the USB port when not in use.
- Do not attempt to charge a battery if it is swollen or hot.
- **Land your model immediately when the battery begins to lose power. Recharge the battery before attempting another flight.** A dangerous situation can occur when attempting to recharge an over-discharged battery!
- ALWAYS keep a supply of sand accessible when charging. Dumping sand on the battery will extinguish the LiPo chemical fire.
- ALWAYS KEEP OUT OF REACH OF CHILDREN.

CHARGING THE FLIGHT BATTERY

WARNING!! The charger supplied with the Heli-Max Axe 100 FP Helicopter contains protective circuitry. If you experience any difficulties while charging the battery, please disconnect the battery from the charger and unplug the charger from the power source. Allow the battery and charger to rest for two hours as this will allow the charge protection circuit to reset. If this issue re-occurs during normal use, please contact technical support for further assistance.



❑ Plug the USB charger into your USB port. The *power indicator light* on the charger will illuminate red indicating that the charger is ready for use.

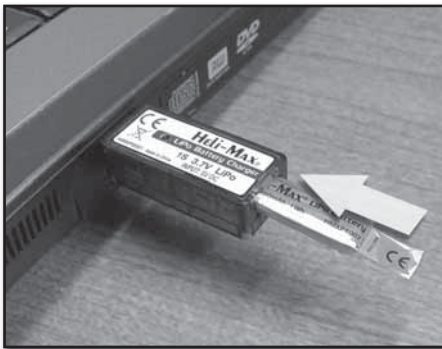

❑ Plug the battery into the charger. The indicator light will start flashing, indicating that the battery is being charged. Once the battery is completely charged, the charge indicator light will stop flashing. Disconnect the battery from the charger. Under normal operating conditions, the battery may take up to 60 minutes to recharge.

Charger Indications	Power Indicator	
Ready to charge battery.	Solid	* Once the battery has been disconnected from the charger contact technical support for further assistance.
Charging	Flashing	
Battery is fully charged.	Solid	
Charger is not powered.	Off	
Charger error*	Flashing	

Heli-MAX®

INSTALL THE TRANSMITTER BATTERIES

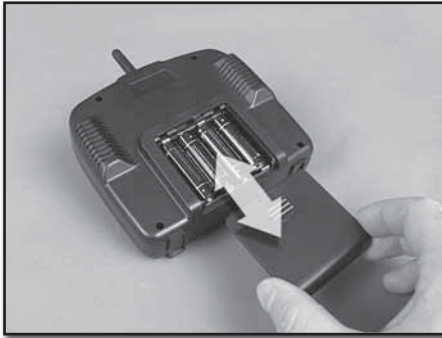

- ❑ Carefully remove the battery door and install four AA batteries. Double check the polarity of each battery. Slide the battery cover back into place.

Heli-MAX®

TRANSMITTER CONTROLS

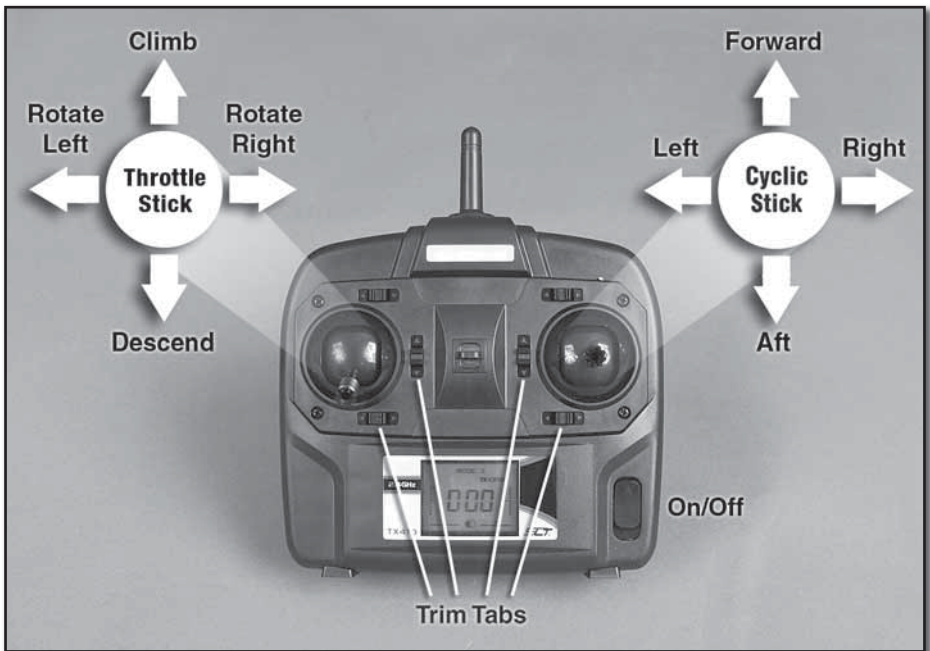

All controls are described with the tail pointing directly toward you. This is the best way to fly in the beginning since it keeps the control inputs oriented the same direction. Once you start getting comfortable you can work on side hovering and nose-in.

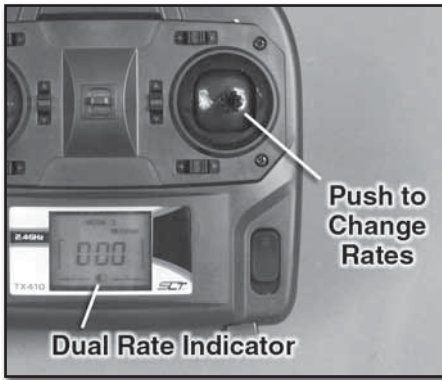

The dual rate switch provides dual control rates for the cyclic and tail rotor controls. Please use the low rate until you become accustomed to your Axe 100 FP. Change the dual rate using a quick push of the right stick. To adjust the dual rate, push and "hold" the right stick and move the throttle stick to the desired percentage. Release the right stick to set.

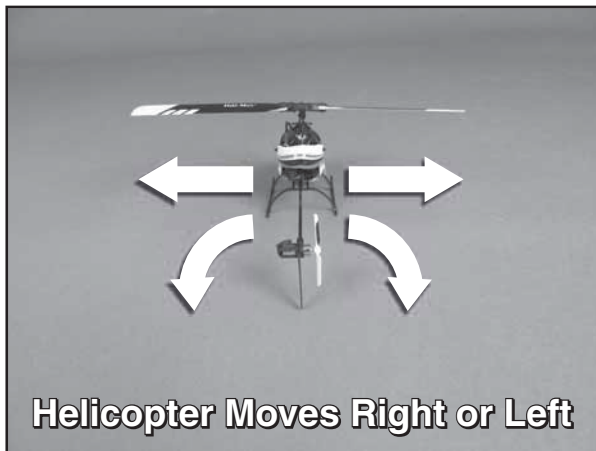

Helicopter Moves Right or Left



Moving the **cyclic stick right or left** will cause the helicopter to tilt and start moving that direction.

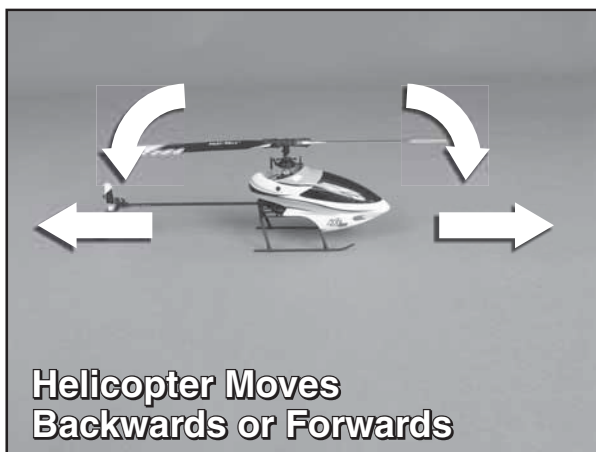

Helicopter Moves Backwards or Forwards



Moving the **cyclic stick forward or backward** will cause the helicopter to tilt and start moving that direction.

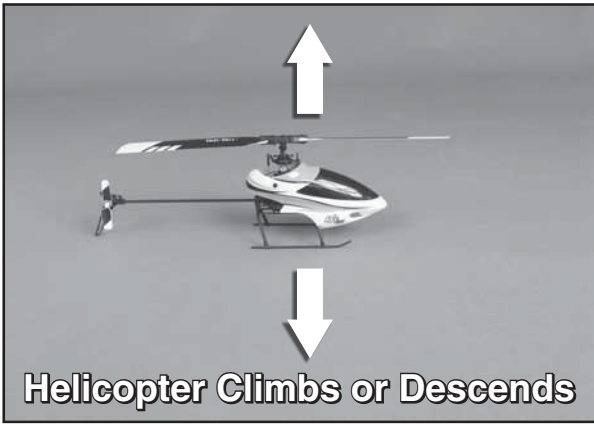

Moving the **throttle stick up or down** will cause the helicopter to climb or descend.

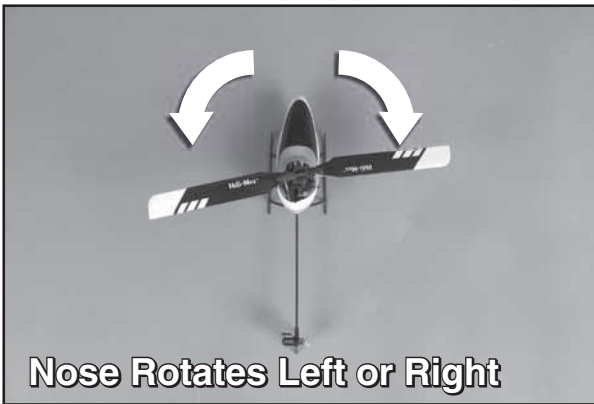

Moving the **tail rotor stick left or right** will cause the helicopter nose to rotate in that direction.

Heli-Max® ***TURNING THE MODEL ON***



- ❑ Move the throttle stick to the lowest position and then turn the transmitter on.



Electric motors are very dangerous. Do not work on the model while the flight battery is plugged in as interference may cause the main rotor blades to spin, possibly causing injury to yourself.

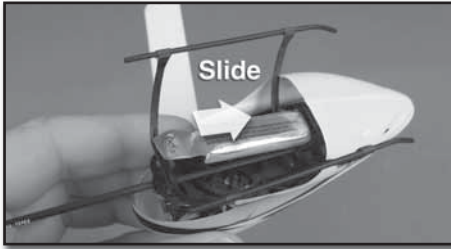

☐ Slide the flight battery into the battery compartment. **NOTE:** The battery will only install one way. The helicopter will be “ON” at this point.

Your Axe helicopter has a safe start feature built in that prevents the motor from activating unless the throttle stick has been lowered to the lowest position. If the motor won't run and turn the main blades, please make sure the throttle stick is all the way down and leave it there for a couple of seconds. Then try moving the stick up slowly.



The Heli-Max Axe 100 FP is a lightweight helicopter. Taking that into consideration, you should only fly indoors or in calm winds less than 5mph. It should be flown in a large area of at least 75 feet [15.25m] square with no obstacles.

Crashing

If you have operated radio control models in the past, then you probably already realize that it is not a matter of “if” you are going to crash, it is a matter of “when” you are going to crash. Once you realize the model is going to collide with something or crash into the ground, you should always bring the throttle stick all the way down to stop the main rotor blades from rotating. If you can remember to do this, chances are you will not damage the helicopter in the crash. The main rotor blades carry a lot of RPM and inertia during flight. Cutting the power to the main rotor blades will prevent most of the crash damage.

Takeoff

Slowly add power, observe the model and make all of the necessary corrections to keep the model level. You will find that model helicopters never allow you to return the sticks to center. You just need to position the stick as needed to maintain a steady hover. With the TAGS system, no trimming is needed.

Hovering

Once the helicopter is up in the air, try to hold the helicopter in one spot. If this is your first model helicopter, it will require some practice. Wind or air currents have a big effect on the stability of the helicopter. Be patient and try to anticipate where the helicopter will move.

Landing

Level the helicopter into a steady hover and slowly decrease power until the helicopter settles onto the ground.

Basic Maneuvers

Slow Pirouettes – Add a small amount of tail rotor (left or right) and try rotating the helicopter slightly sideways and see if you can hold it there. If you feel uncomfortable, then bring the tail back toward you. Once you start getting comfortable, try moving the helicopter to the side. Then turn back and fly back to the other side in straight lines. Then work into rotating the helicopter around 360°, which is called a pirouette. The helicopter can drift during these so make sure you have plenty of room when you first start practicing.

Nose-in Hovering – After pirouettes it's time to move on to nose-in hovering. Take off and climb to 10 feet [3m]. Practice half pirouettes from tail in to nose-in hovering and try to lengthen the delay in between. This will give you a little practice nose-in and still give you a chance to get out of trouble. As your skills improve you'll remain nose-in for longer periods of time.

Forward Flight – Now it's time to work into basic forward flight. Just take the basic hovering maneuvers listed above and slowly fly out farther and faster and always bring the helicopter back after one pass. Practice controlled slow flight in close as well. The more time you spend practicing here the easier things will be later on.

GOOD LUCK AND GREAT FLYING!



Replacement parts for the Heli-Max Axe 100 FP are available using the order numbers in the **Replacement Parts List** that follows. The fastest, most economical service can be provided by your hobby dealer.

To locate a hobby dealer, visit the Heli-Max web site at www.helimax-rc.com. Choose "Where to Buy" at the bottom of the page.

Parts may also be ordered directly from Hobby Services by calling (217) 398-0007, or via facsimile at (217) 398-7721, but full retail prices and shipping and

handling charges will apply. Illinois and Nevada residents will also be charged sales tax. If ordering via fax, include a Visa® or MasterCard® number and expiration date for payment.

Mail parts orders **Hobby Services**
and payments by 3002 N. Apollo Drive, Suite 1
personal check to: Champaign, IL 61822

Be certain to specify the order number exactly as listed in the **Replacement Parts List**. Payment by credit card or personal check only; no C.O.D.

If additional assistance is required for any reason contact Product Support by e-mail at helihotline@hobbico.com, or by telephone at (217) 398-8970.



Key No.	Part No.	Part Name
1	HMXE2105	Main Blade
2	HMXE2135	Blade Grips
3	HMXE2136	Screw Set (all)
4	HMXE2137	Feathering Shaft
5	HMXE2138	Blade Grip Spacers
6	HMXE2139	Rubber Dampeners
7	HMXE2140	Rotor Head
8	HMXE2141	Rotor Head Linkage
9	HMXE2142	Main Shaft
10	HMXE2143	Swashplate
11	HMXE2109	Main shaft collar
12	HMXE2144	Bearing Set
13	HMXE2145	Main Frame
14	HMXG8028	Main Motor
15	HMXM2038	TAGs 3-1 Control Board
16	HMXE2146	Canopy
17	HMXE2147	Main Gear
18	HMXE2148	Landing Skid w/battery mount
19	HMXE2149	Servo Linkages
20	HMXE2150	Servo Arms with metal ball joint
21	HMXE2151	Canopy Servo Mount
22	HMXM2037	Servo
23	HMXG8029	Tail Motor Tail Boom Assembly
24	HMXE2152	Tail Rotor Blade
25	HMXP1007	1S LiPo Battery
	HMXJ2024	410 SLT Transmitter
	HMXP2021	1S USB Charger

Axe 100 FP Main Frame

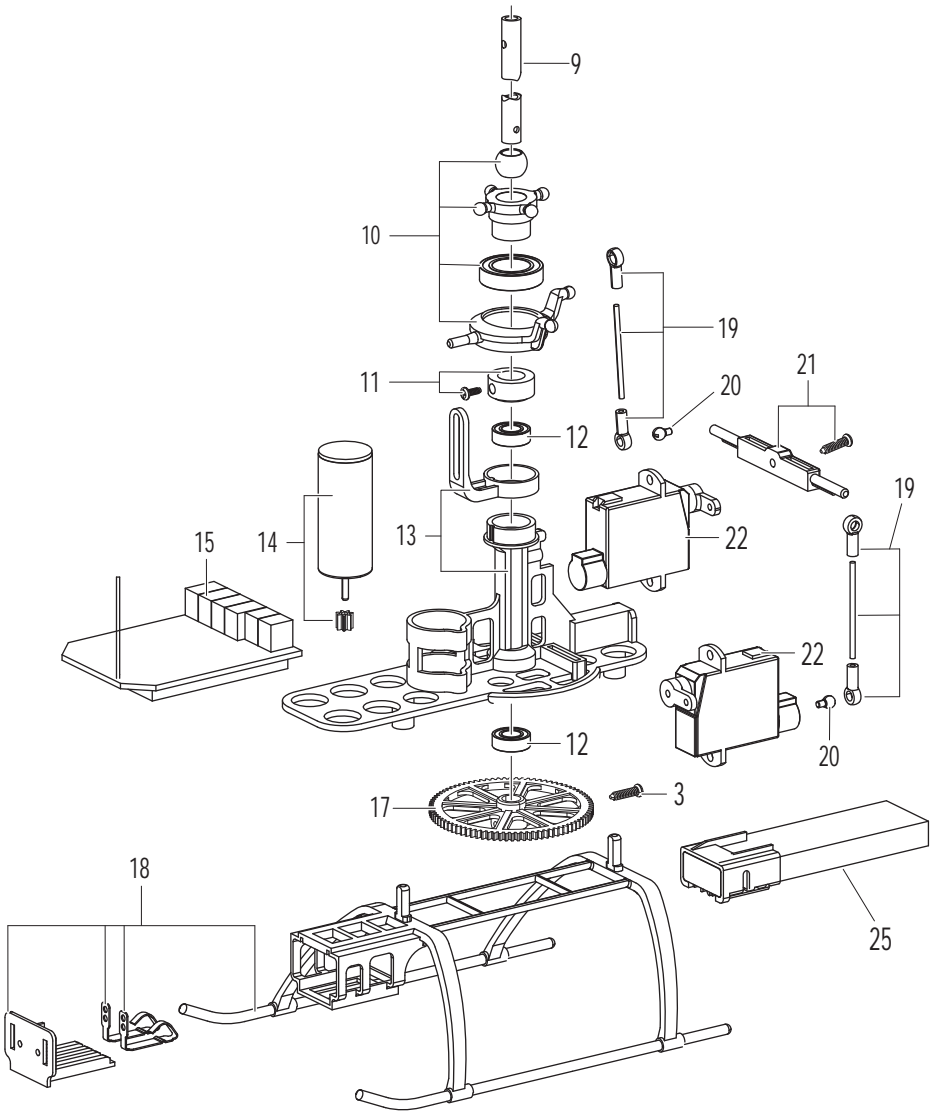

Axe 100 FP Rotor Head

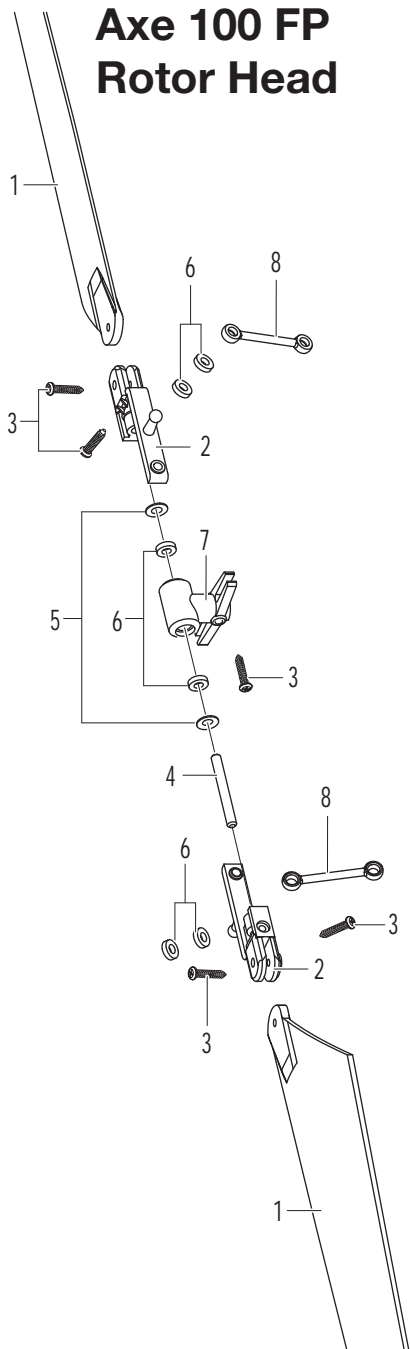

Axe 100 FP Tail

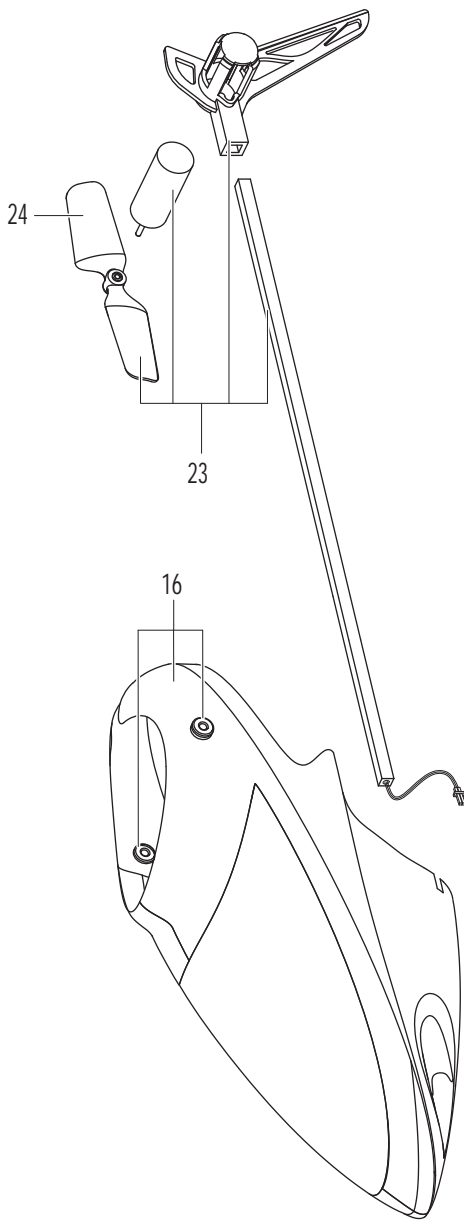

FCC REQUIREMENT This device complies with part 15 of the FCC rules. Operation is subject to the following two conditions.



- (1) This device may not cause harmful interference.
- (2) This device must accept any interference received, including interference that may cause undesired operation.

NOTE: THE MANUFACTURER IS NOT RESPONSIBLE FOR ANY RADIO OR TV INTERFERENCE CAUSED BY UNAUTHORIZED MODIFICATIONS TO THIS EQUIPMENT. SUCH MODIFICATIONS COULD VOID THE USER'S AUTHORITY TO OPERATE THE EQUIPMENT.

CE COMPLIANCE INFORMATION FOR THE EUROPEAN UNION

Instructions for Disposal of Waste Equipment by Private Users in the European Union:

This symbol on the product or its packaging indicates this product must not be disposed of with other household waste. Instead, it is the user's responsibility to dispose of their waste equipment by handing it over to a designated collection point for the recycling of waste electrical and electronic equipment. The separate collection and recycling of your waste equipment at the time of disposal will help to conserve natural resources and ensure that it is recycled in a manner that protects human health and the environment. For more information about where you can drop off your waste equipment for recycling, please contact your local city office, your household waste disposal service or location where you purchased the product.



Declaration of Conformity:

Product: Heli-Max TX410 2.4GHz 4-Channel Tx Rx

Item number: HMXJ2024 TX410, Equipment class: 1

TX410 transmitter: The objects of the declaration described here are in conformity with the requirements of the specifications listed below, following the provisions of the European 2006/95/EC Low Voltage Directive:

EN 60950-1:2006 Safety

The objects of the declaration described here are in conformity with the requirements of the specifications listed below, following the provisions of the European R&TTE directive 1995/5/EC:

ETSI EN 300 328 V1.7.1 Technical requirements for radio equipment

ETSI EN 301 489-1 V1.8.1, 301 489-17 V1.3.2 General EMC requirements for radio equipment

Hobbico, Inc.
2904 Research Road
Champaign, IL USA 61826



The associated regulatory agencies of the following countries recognize the noted certifications to this product as authorized for sale and use.

UK	DE	DK	BG	SE	FI	GR
EE	LV	LT	PL	CZ	SK	HU
RO	SI	AT	IT	ES	PT	IE
NL	LU	MT	CY			