

# Heli-Max™

# AXE™ EZ

EASY TO FLY, WITH  
COUNTER ROTATING BLADES

## INSTRUCTION MANUAL



**Rotor Span:** 13.5 in [340mm]  
**Height:** 7 in [180mm]  
**Length:** 14.5 in [370mm]  
**Weight:** 7.5 oz [213g]  
**Radio:** Tactic 4-Channel FM  
**Motor:** 130 Brushed motor

## WARRANTY

Heli-Max™ guarantees this kit to be free from defects in both material and workmanship at the date of purchase. This warranty does not cover any component parts damaged by use or modification. **In no case shall Heli-Max's liability exceed the original cost of the purchased kit.** Further, Heli-Max reserves the right to change or modify this warranty without notice.

In that Heli-Max has no control over the final assembly or material used for final assembly, no liability shall be assumed nor accepted for any damage resulting from the use by the user of the final user-assembled product. By the act of using the user-assembled product, the user accepts all resulting liability.

**If the buyer is not prepared to accept the liability associated with the use of this product, the buyer is advised to return this kit immediately in new and unused condition to the place of purchase.**

To make a warranty claim, send the defective part or item to Hobby Services at this address.

**Hobby Services  
3002 N. Apollo Dr., Suite 1  
Champaign, IL 61822  
USA**

Include a letter stating your name, return shipping address, as much contact information as possible (daytime telephone number, fax number, e-mail address), a detailed description of the problem and a photocopy of the purchase receipt. Upon receipt of the package the problem will be evaluated as quickly as possible.

**READ THROUGH THIS INSTRUCTION MANUAL FIRST. IT CONTAINS IMPORTANT INSTRUCTIONS AND WARNINGS CONCERNING THE ASSEMBLY AND USE OF THIS MODEL.**

# Heli-Max™

Champaign, Illinois  
(217) 398-8970  
E-mail: helihotline@hobbico.com

# TABLE OF CONTENTS

INTRODUCTION .....2  
 AMA .....2  
 SAFETY PRECAUTIONS .....2  
 ADDITIONAL ITEMS REQUIRED .....3  
 ORDERING REPLACEMENT PARTS .....3  
 KIT INSPECTION .....4  
 KIT CONTENTS .....4  
 METRIC/INCH RULER .....4  
 ASSEMBLY INSTRUCTIONS .....5  
 LITHIUM BATTERY HANDLING & USAGE .....5  
 GET THE MODEL READY TO FLY .....6  
 PREFLIGHT .....6  
 AMA SAFETY CODE (excerpts) .....6  
 CONTROLS .....7  
 FLYING .....8  
 MAINTENANCE .....9  
 PARTS LIST .....10  
 EXPLODED VIEW .....11

# INTRODUCTION

Thank you for purchasing the Heli-Max AXE™ EZ Helicopter. We are certain you will get many hours of enjoyment out of this model. If you should have any questions or concerns please feel free to contact us at [helicoptersupport@greatplanes.com](mailto:helicoptersupport@greatplanes.com).

For the latest technical updates or manual corrections to the AXE EZ visit the Heli-Max web site at:

[www.helihotline@hobbico.com](http://www.helihotline@hobbico.com)

Open the “Helicopters” link, and then select the AXE EZ. If there is new technical information or changes to this model a “tech notice” box will appear in the upper left corner of the page.

**CAUTION:** Be aware that the AXE EZ operates on the same frequency band as larger R/C models. If flying your AXE EZ within five miles of an R/C site, there is a real possibility that you could be operating your model on the same frequency (channel) as another R/C pilot. If this happens, a crash will result—with the person flying the more expensive model suffering the greater loss (and having greater potential for property damage or injury). The best thing to do is to join an R/C club and fly at the site where frequency control measures will be in effect. If you insist on flying elsewhere, **always be aware of your proximity to R/C flying sites.**

# AMA

We urge you to join the AMA (Academy of Model Aeronautics) and a local R/C club. The AMA is the governing body of model aviation and membership is required to fly at AMA clubs. Though joining the AMA provides many benefits, one of the primary reasons to join is liability protection. Coverage is not limited to flying at contests or on the club field. It even applies to flying at public demonstrations and air shows. Failure to comply with the Safety Code (excerpts printed in the back of the manual) may endanger insurance coverage. Additionally, training programs and instructors are available at AMA club sites to help you get started the right way. There are over 2,500 AMA chartered clubs across the country. Contact the AMA at the address or toll-free phone number below.



**Academy of Model Aeronautics**  
 5151 East Memorial Drive  
 Muncie, IN 47302  
 Tele: (800) 435-9262  
 Fax (765) 741-0057  
 Or via the Internet at:  
<http://www.modelaircraft.org>

**IMPORTANT!!!** Two of the most important things you can do to preserve the radio controlled model hobby are to avoid flying near full-scale aircraft and avoid flying near or over groups of people.

# SAFETY PRECAUTIONS

**Failure to follow these safety precautions may result in severe injury to yourself and others.**

Keep your face and body as well as all spectators away from the plane of rotation of the rotors whenever the battery is connected.

Keep these items away from the rotors: loose clothing, shirt sleeves, ties, scarfs, long hair or loose objects such as pencils or screwdrivers that may fall out of shirt or jacket pockets into the rotors.

The spinning blades of a model helicopter can cause serious injury. When choosing a flying site for your AXE EZ, stay clear of buildings, trees and power lines. AVOID flying in or near crowded areas. DO NOT fly close to people, children or pets. Maintain a safe pilot-to-helicopter distance while flying.

1. Your AXE EZ should not be considered a toy, but rather a sophisticated, working model that functions very much like a full-size helicopter. Because of its performance capabilities, the AXE EZ, if not assembled and operated correctly, could possibly cause injury to yourself or spectators and damage to property.

2. You must assemble the model **according to the instructions**. Do not alter or modify the model, as doing so may result in an unsafe or unflyable model. In a few cases the instructions may differ slightly from the photos. In those instances the written instructions should be considered as correct.

3. You must correctly install all R/C and other components so that the model operates correctly on the ground and in the air.

4. You must check the operation of the model before **every** flight to insure that all equipment is operating and that the model has remained structurally sound. Be sure to check linkages or other connectors often and replace them if they show any signs of wear or fatigue.

5. If you are not an experienced pilot or have not flown this type of model before, we recommend that you get the assistance of an experienced pilot in your R/C club for your first flights. If you're not a member of a club, your local hobby shop has information about clubs in your area whose membership includes experienced pilots.

We, as the manufacturer, provide you with a top quality, thoroughly tested helicopter and instructions, but ultimately the quality and flyability of your finished model depends on how you build it; therefore, we cannot in any way guarantee the performance of your completed model, and no representations are expressed or implied as to the performance or safety of your completed model.

**Remember: Take your time and follow the instructions to build a safe and enjoyable model.**

## ADDITIONAL ITEMS REQUIRED

- Eight "AA" Alkaline Batteries for the Transmitter

## ORDERING REPLACEMENT PARTS

Replacement parts for the Heli-Max AXE EZ are available using the order numbers in the **Parts List** on page 10. The fastest, most economical service can be provided by your hobby dealer.

To locate a hobby dealer, visit the Hobbico web site at **www.hobbico.com**. Choose "Where to Buy" at the bottom of the menu on the left side of the page. Follow the instructions provided on the page to locate a U.S., Canadian or International dealer.

Parts may also be ordered directly from Hobby Services by calling (217) 398-0007, or via facsimile at (217) 398-7721, but full retail prices and shipping and handling charges will apply. Illinois and Nevada residents will also be charged sales tax. If ordering via fax, include a Visa® or MasterCard® number and expiration date for payment.

Mail parts orders and payments by personal check to:

Hobby Services  
3002 N. Apollo Drive, Suite 1  
Champaign, IL 61822

Be certain to specify the order number exactly as listed in the **Parts List**. Payment by credit card or personal check only; no C.O.D.

If additional assistance is required for any reason contact Product Support by e-mail at **productsupport@greatplanes.com**, or by telephone at (217) 398-8970.

# KIT INSPECTION

Before starting assembly, take an inventory of the AXE EZ to make sure it is complete, and inspect the parts to make sure they are of acceptable quality. If any parts are missing or are not of acceptable quality, or if you need assistance with assembly, contact **Product Support**. When reporting defective or missing parts, use the part names exactly as they are written in the Kit Contents list.

Heli-Max Product Support:  
 3002 N. Apollo Drive, Suite 1  
 Champaign, IL 61822  
 Telephone: (217) 398-8970, ext. 5  
 Fax: (217) 398-7721  
 E-mail: [airsupport@greatplanes.com](mailto:airsupport@greatplanes.com)

# KIT CONTENTS

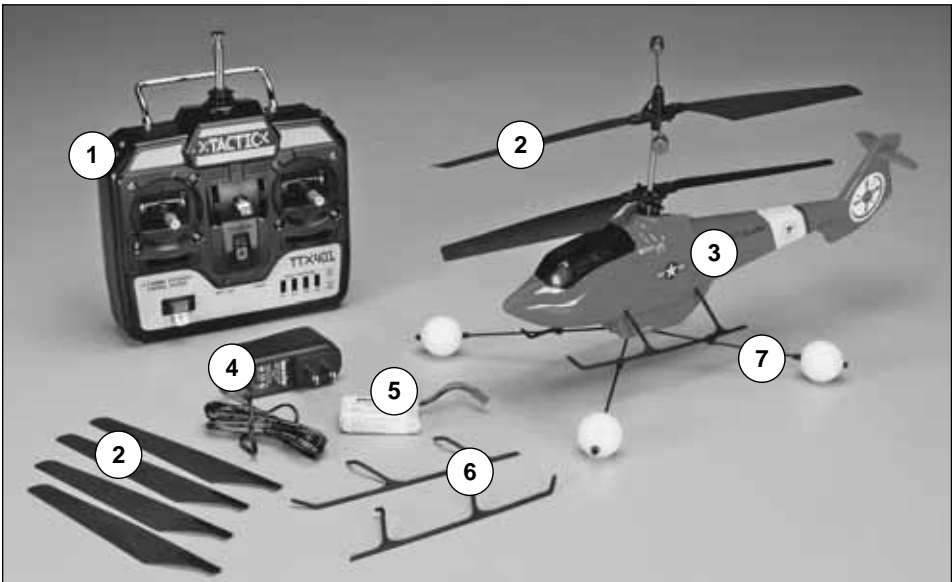

- Kit Contents**
1. 4-Channel Transmitter
  2. Main Rotor Blades (4 installed on heli & 4 spares)
  3. Body
  4. 110V Wall Charger
  5. 7.4V LiPo Battery
  6. Extra Landing Gear (L&R)
  7. Training Gear (Carbon Rods, Fittings, Foam Balls)

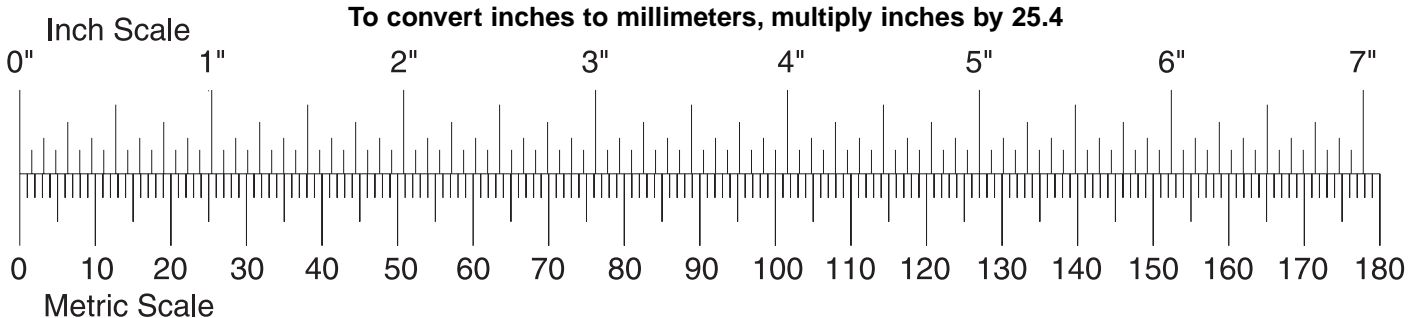

## ASSEMBLY INSTRUCTIONS

### Install Batteries in the Transmitter



❑ Remove the battery cover from the back of the transmitter, remove the battery box and install eight “AA” batteries in the transmitter. Double-check the polarity of each battery before replacing the battery cover.

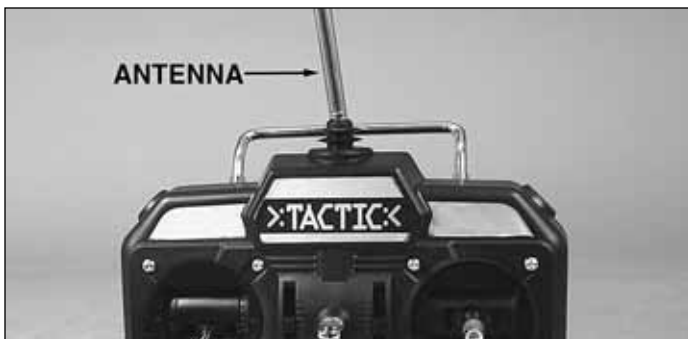

❑ Insert the transmitter antenna into the top of the transmitter and turn it clockwise until it is tight.



❑ Turn on the transmitter using the power switch as shown above. Check the LEDs on the front of the transmitter. Only the Green LED should be on. If the Red LED is on, then the batteries need replacing. Turn the transmitter off for now.

### Assemble Training Gear

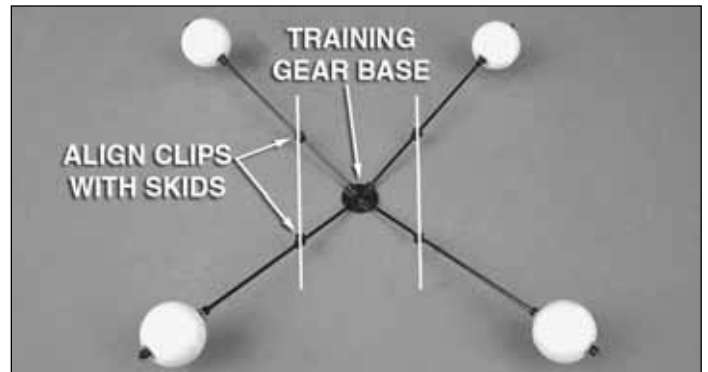

❑ Slide the four landing gear clips onto the training gear legs as shown. Install the four training gear legs into the training gear base. Align the clips up with the skids and install the training gear onto the helicopter.

## LITHIUM BATTERY HANDLING & USAGE

**WARNING!!** Read the entire instruction sheet included with this battery. Failure to follow all instructions could cause permanent damage to the battery and its surroundings, and cause bodily harm!

- ONLY use a LiPo approved charger. NEVER use a NiCd/NiMH peak charger!
- NEVER charge in excess of 4.20V per cell.
- NEVER charge at currents greater than 1C.
- ALWAYS set charger's output volts to match battery volts.
- ALWAYS charge in a fireproof location.
- NEVER trickle charge.
- NEVER allow the battery temperature to exceed 150° F [65° C].
- NEVER disassemble or modify pack wiring in any way or puncture cells.
- NEVER discharge below 2.5V per cell.
- NEVER place on combustible materials or leave unattended during charge or discharge.
- ALWAYS KEEP OUT OF REACH OF CHILDREN.

## GET THE MODEL READY TO FLY

### Charging the Flight Battery



☐ Plug the charger into an AC outlet. The light on the charger should be Green. Plug the battery into the charger. The light on the charger will turn Red. Once the battery is charged the light will turn Green again.

**WARNING!** Do not leave the battery unattended while it is charging. If after an hour the battery becomes hot, disconnect it immediately.

### Electric Motor Warning

Electric motors are very dangerous. Do not work on the model while the flight battery is plugged in as interference may cause the main rotor blades to spin, possibly causing injury to yourself.

### Install the Battery

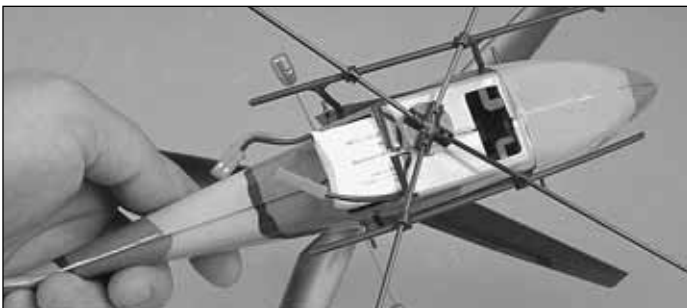

Slide the battery into the AXE EZ as shown in the photo above.

### Turning the Model On

Always turn the Transmitter on first and then, with the AXE EZ sitting still, plug the battery into the ESC. The AXE EZ will need to sit still for 10 seconds so the gyro can initialize and determine center. If the AXE EZ is moved during this initialization the gyro will not operate properly.

Always step 15 feet away from the AXE EZ before flipping any switches or operating the throttle. Do not hold onto the model and run it up. Safety First.

### Range Check

Ground check the operational range of your radio before the first flight of the day. For safety reasons unplug the main motor so power cannot be applied to the main rotor blades. With the transmitter antenna collapsed and the receiver and transmitter on, you should be able to walk at least 50 feet away from the model and still have control. Have an assistant stand by your model and while you work the controls, tell you what the servos are doing. If the controls do not respond correctly, **do not fly!** Find and correct the problem first. Look for loose servo connections or broken wires, corroded wires on old servo connectors, poor solder joints in your battery pack or a defective cell or a damaged receiver crystal from a previous crash.

### Balance the Main Blades

The AXE EZ main rotor blades are already balanced and ready to fly.

## PREFLIGHT

### Identify Your Model

No matter if you fly at an AMA sanctioned R/C club site or if you fly somewhere on your own, you should always have your name, address, telephone number and AMA number on or inside your model. It is **required** at all AMA R/C club flying sites and AMA sanctioned flying events. Fill out the identification tag on page 10 and place it on or inside your model.

## AMA SAFETY CODE (excerpts)

Read and abide by the following excerpts from the Academy of Model Aeronautics Safety Code. For the complete Safety Code refer to *Model Aviation* magazine, the AMA web site or the Code that came with your AMA license.

### General

1) I will not fly my model aircraft in sanctioned events, air shows, or model flying demonstrations until it has been proven to be airworthy by having been previously, successfully flight tested.

2) I will not fly my model aircraft higher than approximately 400 feet within 3 miles of an airport without notifying the airport operator. I will give right-of-way and avoid flying in the proximity of full-scale aircraft. Where necessary, an observer shall be utilized to supervise flying to avoid having models fly in the proximity of full-scale aircraft.

3) Where established, I will abide by the safety rules for the flying site I use, and I will not willfully and deliberately fly my models in a careless, reckless and/or dangerous manner.

5) I will not fly my model unless it is identified with my name and address or AMA number, on or in the model. **Note:** This does not apply to models while being flown indoors.

7) I will not operate models with pyrotechnics (any device that explodes, burns, or propels a projectile of any kind).

### Radio Control

1) I will have completed a successful radio equipment ground check before the first flight of a new or repaired model.

2) I will not fly my model aircraft in the presence of spectators until I become a qualified flier, unless assisted by an experienced helper.

3) At all flying sites a straight or curved line(s) must be established in front of which all flying takes place with the other side for spectators. Only personnel involved with flying the aircraft are allowed at or in the front of the flight line. Intentional flying behind the flight line is prohibited.

4) I will operate my model using only radio control frequencies currently allowed by the Federal Communications Commission.

5) **I will not knowingly operate my model within three miles of any pre-existing flying site except in accordance with the frequency sharing agreement listed** (in the complete AMA Safety Code).

9) Under no circumstances may a pilot or other person touch a powered model in flight; **nor should any part of the model other than the landing gear, intentionally touch the ground, except while landing.**



Always turn the Transmitter on first and then with the AXE EZ sitting still plug the battery into the ESC. The AXE EZ will need to sit still for 10 seconds so the gyro can initialize and can determine center. If the AXE EZ is moved during this initialization then the gyro will not operate properly.

There is a safety built into the AXE EZ that prevents the motor from activating unless the collective stick has been lowered to its lowest position. If the motor won't run and turn the main blades, please make sure the collective stick is all the way down and leave it there for a couple of seconds. Then try moving the stick up slowly.

### Transmitter Controls

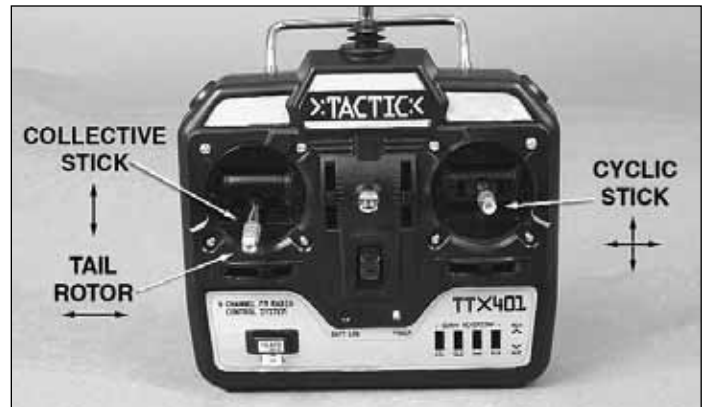

All controls described as follows are with the tail pointing directly towards you. This is the best way to start out since it keeps the control inputs orientated the same. Once you start getting comfortable you can work on side hovering and nose-in.

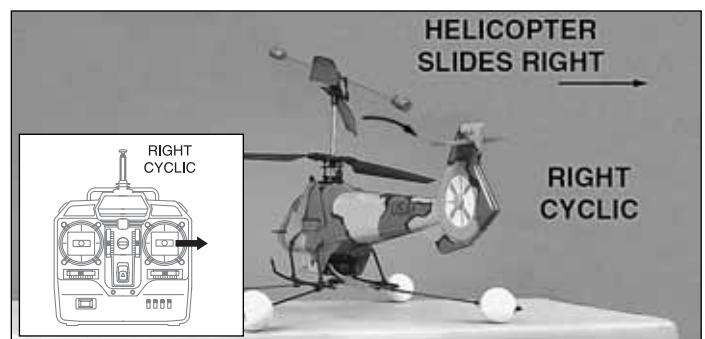

Moving the cyclic stick right will cause the helicopter to tilt right and it will start moving that direction.

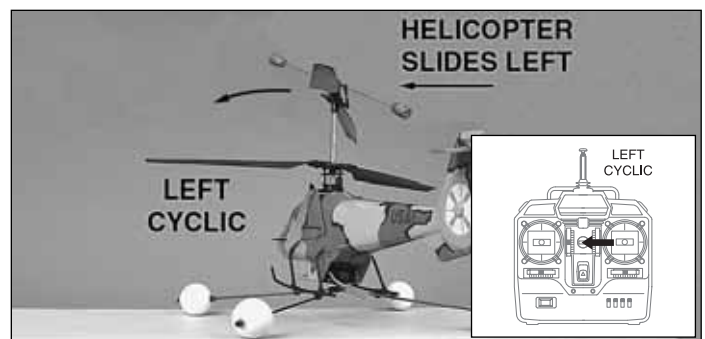

Moving the cyclic stick left will cause the helicopter to tilt left and start moving in that direction.

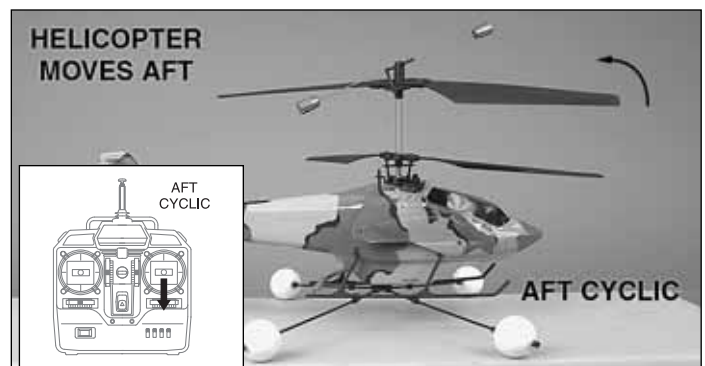

Moving the cyclic stick backwards (towards you) will cause the helicopter to tilt backwards and start moving that direction.

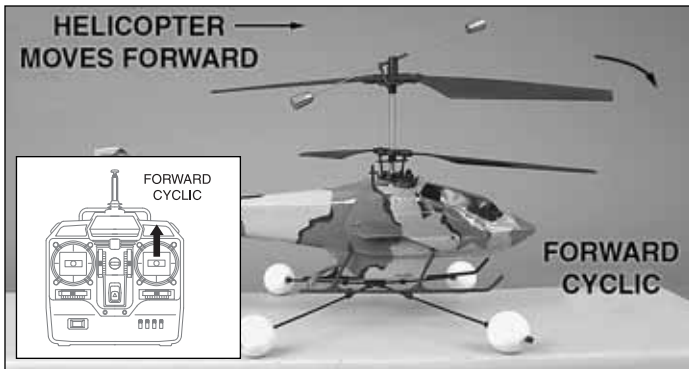

Moving the cyclic stick forward (away from you) will cause the helicopter to tilt forward and start moving that direction.



Moving the collective stick up (away from you) will cause the helicopter to climb higher.



Moving the collective stick down (towards you) will cause the helicopter to descend.

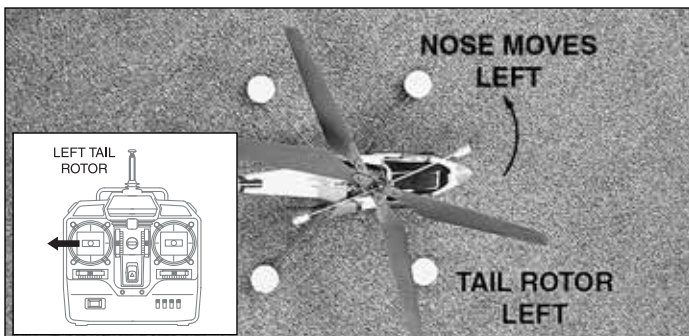

Moving the tail rotor stick towards the left will cause the helicopter nose to rotate left (counterclockwise).

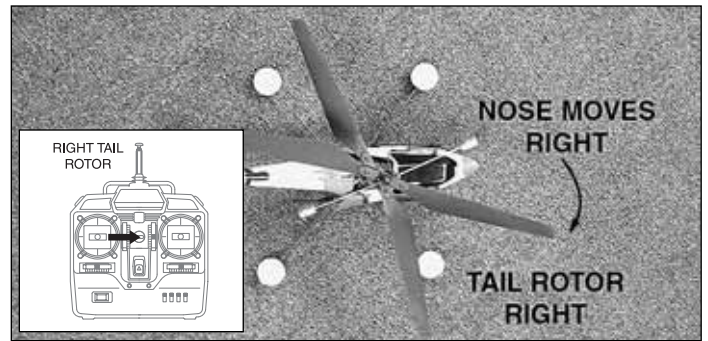

Moving the tail rotor stick towards the right will cause the helicopter nose to rotate right (clockwise).

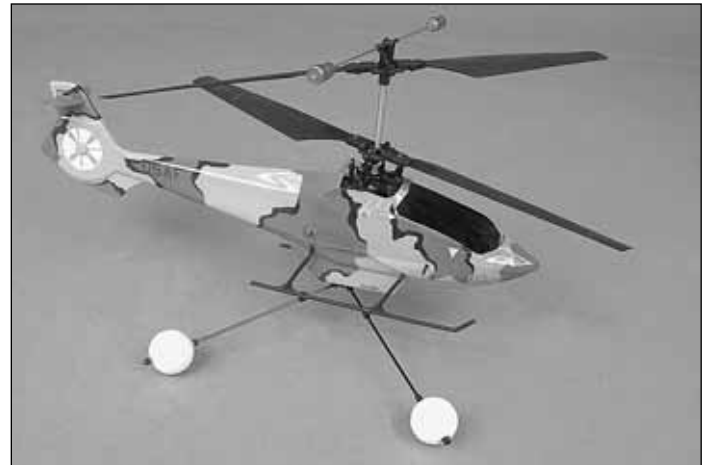

The training gear is a big help to beginners. They soften not so perfect landings and help to prevent the helicopter from tipping over. Even if you have experience flying a helicopter, please consider using the supplied training gear for the first few flights.

## FLYING

The Heli-Max AXE EZ is an extremely lightweight model helicopter. Taking that into consideration **you should only fly the AXE EZ indoors or in calm winds.**

### Takeoff

Slowly add power and observe the model. If you feel it needs trimming do so before lift off. You will quickly find that model helicopters never allow you to return the sticks to center. You just need to hold the sticks as needed to keep a steady hover. So please don't fight the trim too much as it is a normal thing to experience.

You will notice the cyclic controls lag behind a little from your inputs. This is perfectly normal and something you get the feel for with time. It's normal to drift around a little in a hover until you get used to flying the model. The cyclic controls on the AXE EZ are fairly sensitive so only small movements are necessary.

## Hovering

Once the helicopter is up in the air simply try to hold the helicopter in one spot as best you can. This can take some practice and wind has a big effect on the stability of the helicopter as well. Be patient and slowly work forward as trying to rush the learning process can be costly.

## Landing

Level the helicopter into a solid hover and slowly decrease power until the helicopter settles onto the ground.

## Basic Maneuvers

Once you get comfortable with hovering at different orientations and landing, it's time to move on to more advanced maneuvers.

**Slow Pirouettes** – Add a small amount of tail rotor (left or right) and try rotating the helicopter slightly sideways and see if you can hold it there. If you get uncomfortable bring the tail back towards you. Once you start getting comfortable try moving the helicopter to the side and turning back and fly back to the other side in straight lines.

Once you get that down you can try rotating the helicopter around 360 degrees which is called a pirouette. The helicopter can drift during these so make sure you have plenty of room when you first start practicing.

**Nose-in Hovering** – After pirouettes it's time to move on to nose-in hovering. The best bet is to wait for a calm day. Take off and climb to 15 feet, practice half pirouettes from tail in to nose-in hovering and try to lengthen the delay in between. This will give you a little practice nose-in and still give you a chance to get out of trouble. As you improve you'll remain nose-in for longer periods of time.

**GOOD LUCK AND GREAT FLYING!**



## E-Board Adjustments

**Note:** All of the e-board adjustments are factory pre-set and test flown at the factory. If you replace the e-board with a new one or need to re-adjust it for any reason, please follow the guidelines below. Never turn these adjustments more than 180° and only use a plastic non-conductive screwdriver to make the adjustment.

**Tip:** If you need to make some adjustments consider using a felt-tip marker and place a mark on the adjusters so you can always return them back to the factory defaults.

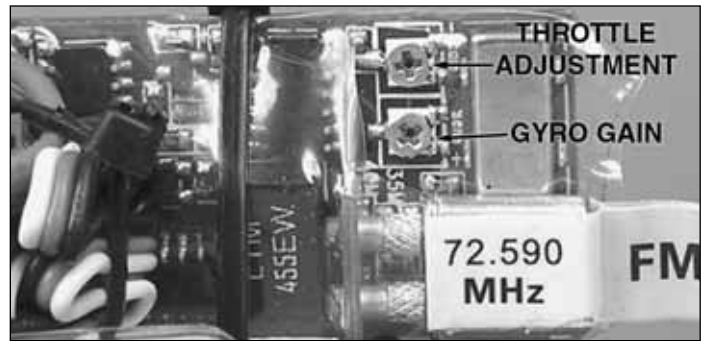

**Throttle Adjustment** – Use this adjustment if the helicopter does not have enough power to lift off the ground.

**Gyro Gain** – Typically too little gyro gain causes the tail to slowly move around and drift. With the gyro gain too high, you will notice a very fast oscillation in the tail known as "Wag." This adjustment is not very critical so please don't spend a lot of time trying to get "the best" setting possible.

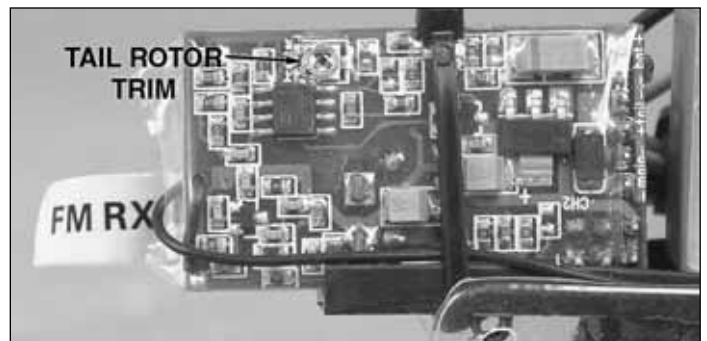

**Tail Rotor Trim** – If the helicopter wants to drift one direction in a stable hover then try using this adjustment. The adjustment is very sensitive so only make small changes.

This model belongs to:

_____
Name
_____
Address
_____
City, State Zip
_____
Phone number
_____
AMA number

**Make a copy of this identification tag and put it on or inside your model.**

## AXE EZ Parts List

Key #	SKU	Description	# of pcs.
01	HMXE7202	Battery Box Support	1
02	HMXE8408	Inner Shaft Collar Assembly	1
03	HMXE8414	Rotor Gear	2
04	HMXE8411	Inner Rotor Shaft Assembly	1
05	HMXE7302	Ball Bearing Set	1
06	HMXE7341	Screw Set	1
07	HMXE8412	Outer Rotor Shaft	1
08	HMXE7911	Main Frame	1
09	HMXE7437	Fuselage Mounting Post	2
10	HMXE8003	Rear Main Motor 130	1
11	HMXE7912	Servo Mount	1
12	HMXE8301	Lower Rotor Blade	1
13	HMXE8314	Blade Grip Assembly	1
14	HMXE8302	Upper Rotor Blade	1
15	HMXE7807	Flybar Link Control	1
16	HMXE7808	Flybar Assembly	1
17	HMXE7809	Flybar Stabilizer	2
18	HMXE8413	Bearing Holder	1
19	HMXE8616	Lower Rotor Head	1
20	HMXE9003	Swash Plate Assembly	1
21	HMXE7628	Main Blade Control Link	2
22	HMXE7629	Pushrod	2
23	TACM0101	TSX101 Micro Servo	1
24	HMXE7431	Fuse White w/ Decal	1
24	HMXE7432	Fuse Blue w/ Decal	1
24	HMXE7433	Fuse Red Orange w/ Decal	1
24	HMXE7434	Fuse Yellow w/ Decal	1
24	HMXE7435	Fuse Gray w/ Decal	1
24	HMXE7436	Fuse Desert w/ Camouflage Decal	1
26	TACM9100	TCB100 E-Board RX/ESC/Gyro	1
27	HMXE8004	Front Main Motor 130	1
28	HMXE8409	Outer Shaft Collar Assembly	1
29	HMXE8903	Landing Skid	2
30	HMXE8904	Landing Skid Mounting	2
31	HMXE7203	Battery Box	1
32	GPMP0400	800mAh 7.4V LiPo Battery	1
	HMXE7509	Decal Sheet	1
	TACJ0401	Transmitter TTX401 4-channel	1
	TACM4404	Antenna TTX401	1
	HMXE2026	Training Gear Set	1
	GPMM3300	LiPo AC Charger	1

# Exploded View

