



# Super Cub

## INSTRUCTION MANUAL

### SPECIFICATIONS

<b>Wingspan:</b>	48 in [1220mm]
<b>Wing Area:</b>	354 in <sup>2</sup> [22.8 dm <sup>2</sup> ]
<b>Weight:</b>	30.4 oz [860 g]
<b>Wing Loading:</b>	12.4 oz/ft <sup>2</sup> [38 g/dm <sup>2</sup> ]
<b>Length:</b>	33 in [840mm]
<b>Radio:</b>	4-channel (required)
<b>Battery and ESC:</b>	3s 1300mAh, 16A ESC

### WARRANTY

Hobbico guarantees this kit to be free from defects in both material and workmanship at the date of purchase. This warranty does not cover any component parts damaged by use or modification. **In no case shall Hobbico's liability exceed the original cost of the purchased kit.** Further, Hobbico reserves the right to change or modify this warranty without notice.

In that Hobbico has no control over the final assembly or material used for final assembly, no liability shall be assumed nor accepted for any damage resulting from the use by the user of the final user-assembled product. By the act of using the user-assembled product, the user accepts all resulting liability.

**If the buyer is not prepared to accept the liability associated with the use of this product, the buyer is advised to return**

**this kit immediately in new and unused condition to the place of purchase.**

To make a warranty claim send the defective part or item to Hobby Services at the address below:

#### Hobby Services

3002 N. Apollo Dr. Suite 1  
Champaign IL 61822 USA

Include a letter stating your name, return shipping address, as much contact information as possible (daytime telephone number, fax number, e-mail address), a detailed description of the problem and a photocopy of the purchase receipt. Upon receipt of the package the problem will be evaluated as quickly as possible.

READ THROUGH THIS MANUAL BEFORE STARTING CONSTRUCTION. IT CONTAINS IMPORTANT INSTRUCTIONS AND WARNINGS CONCERNING THE ASSEMBLY AND USE OF THIS MODEL.

## TABLE OF CONTENTS

INTRODUCTION . . . . .	2
SAFETY PRECAUTIONS . . . . .	2
ADDITIONAL ITEMS REQUIRED . . . . .	3
Radio Control System . . . . .	3
Additional Battery and Charging System (Optional) . . . . .	3
Required Assembly Tools . . . . .	3
ORDERING REPLACEMENT PARTS . . . . .	3
KIT INSPECTION . . . . .	4
KIT CONTENTS . . . . .	4
ASSEMBLE THE MODEL . . . . .	5
Mount the Main Landing Gear . . . . .	5
Mount the Vertical and Horizontal Stabilizers . . . . .	5
Hook Up the Controls . . . . .	7
Check the Control Throws . . . . .	8
Increased Elevator Throw for Expert Pilots (Optional) . . . . .	9
Mount the Wing . . . . .	9
FINAL PREPARATION . . . . .	11
Mount the Propeller . . . . .	11
Check the C.G. (Center of Gravity) . . . . .	11
GET THE MODEL READY TO FLY . . . . .	13
Identify Your Model . . . . .	13
Battery Charging Precautions . . . . .	13
FLYING THE PIPER Super CUB . . . . .	13
Find a Suitable Flying Site . . . . .	13
Know Your Frequency . . . . .	13
Perform a Range Check . . . . .	13
Monitor Your Flight Time . . . . .	14
Take Off . . . . .	14
Flying . . . . .	14
Landing . . . . .	15
After Flight . . . . .	15

## INTRODUCTION

Thank you for purchasing the Piper Super Cub RTF (Ready-to-Fly). The Cub is forgiving and “friendly” enough for pilots with little experience, but also responsive enough for experienced pilots who desire a durable Piper Cub that they can “toss” around the sky.

For the latest technical updates or manual corrections to the Super Cub visit the Hobbico web site at [www.hobbico.com](http://www.hobbico.com). Open the “Airplanes” link, then select “Super Cub”. If there is new technical information or changes to this model a “tech notice” box will appear in the upper left corner of the page.

## AMA

If you are not already a member of the AMA, please join! The AMA is the governing body of model aviation and membership provides liability insurance coverage, protects modelers’ rights and interests and is required to fly at most R/C sites.

### ACADEMY OF MODEL AERONAUTICS



5151 East Memorial Drive  
Muncie, IN 47302-9252  
Tele. (800) 435-9262  
Fax (765) 741-0057

Or via the Internet at:

<http://www.modelaircraft.org>

<http://www.modelaircraft.org/parkflyer.aspx>

### IMPORTANT!!!

Two of the most important things you can do to preserve the radio controlled aircraft hobby are to avoid flying near full-scale aircraft and avoid flying near or over groups of people.

## PROTECT YOUR MODEL, YOURSELF & OTHERS... FOLLOW THESE IMPORTANT SAFETY PRECAUTIONS

1. Your Super Cub should not be considered a toy, but rather a sophisticated, working model that functions very much like a full-size airplane. Because of its performance capabilities, the Cessna Skylane, if not assembled and operated correctly, could possibly cause injury to yourself or spectators and damage to property.

2. You must assemble the model **according to the instructions**. Do not alter or modify the model, as doing so may result in an unsafe or unflyable model. In a few cases the instructions may differ slightly from the photos. In those instances the written instructions should be considered as correct.

3. If you are not an experienced pilot or have not flown this type of model before, we recommend that you get the assistance of an experienced pilot in your R/C club for your first flights. If you’re not a member of a club, your local hobby shop has information about clubs in your area whose membership includes experienced pilots.

4. While this kit has been flight tested to exceed normal use, if the plane will be used for extremely high stress flying, such as racing, or if an engine larger than one in the recommended range is used, the modeler is responsible for taking steps to reinforce the high stress points and/or substituting hardware more suitable for the increased stress.

We, as the kit manufacturer, provide you with a top quality, thoroughly tested kit and instructions, but ultimately the quality and flyability of your finished model depends on how you build it; therefore, we cannot in any way guarantee the performance of your completed model, and no representations are expressed or implied as to the performance or safety of your completed model.

## ORDERING REPLACEMENT PARTS

Replacement parts for the Hobbico Flyzone Super Cub are available using the order numbers in the **Replacement Parts List** that follows. The fastest, most economical service can be provided by your hobby dealer or mail-order company.

To locate a hobby dealer, visit the Hobbico web site at [www.hobbico.com](http://www.hobbico.com). Choose "Where to Buy" at the bottom of the menu on the left side of the page. Follow the instructions provided on the page to locate a U.S., Canadian or International dealer.

Parts may also be ordered directly from Hobby Services by calling (217) 398-0007, or fax at (217) 398-7721, but full retail prices and shipping and handling charges will apply. Illinois and Nevada residents will also be charged sales tax. If ordering via fax, include a Visa® or MasterCard® number and expiration date for payment.

Mail parts orders and payments by personal check to:

**Hobby Services**  
3002 N. Apollo Drive, Suite 1  
Champaign, IL 61822

Be certain to specify the order number exactly as listed in the **Replacement Parts List**. Payment by credit card or personal check only; no C.O.D.

If additional assistance is required for any reason, contact Product Support by telephone at (217) 398-8970, or by e-mail at [productsupport@hobbico.com](mailto:productsupport@hobbico.com).

### ADDITIONAL ITEMS REQUIRED

#### Radio Control System

- (8) AA batteries will be required to operate the transmitter (FUGP7308).

#### Additional Battery and Charging System (Optional)

The LiPo battery charger included with your Piper Super Cub RTF is a simple, safe, entry-level charger that charges at a rate of 800mA. The capacity of the included LiPo battery is 1300mAh, so this works out to an approximate charge time (for a discharged battery) of 1 hour, 37 minutes (1300mAh divided by 800mA = 1.625 x 60 minutes = 97 minutes). But some pilots prefer to have several batteries and charge them faster so they can fly more. For charging up to four batteries faster (60 minutes) all at the same time, the Great Planes PolyCharge4™ DC-powered LiPo charger (GPMM3015) is recommended. But unlike the included *ElectriFly* charger, the PolyCharge4 does not have an internal LiPo cell balancer which is a critical component in making sure your LiPo batteries charge efficiently and evenly. So, for each LiPo battery you wish to charge simultaneously, one Great Planes Equinox™ LiPo Cell Balancer (GPMM3160) will also be required. Finally, the PolyCharge4 does not have AC capability, so if wall-charging is a priority a separate A/C 12-Volt power source must also be purchased separately. A suitable power supply for the PolyCharge4 is the Great Planes 12V 12A DC power supply (GPMP0901).

#### Required Assembly Tools

Other than common hobby tools this is the list of adhesives and building supplies that are required to finish the Cub.

- Small needle-nose pliers (HCAR0625) or hemostats (BRUR1302)
- #1 Phillips screwdriver (DTXR0174)
- Thread-locking cement (GPMR6060)
- Small crescent wrench
- Great Planes stick-on lead weight (Optional, GPMQ4485)

### REPLACEMENT PARTS LIST

Order No.	Description
HCAA6310	11.4V LiPo 1300
HCAA6311	Fuselage
HCAA6312	Wing
HCAA6313	Stabilizer
HCAA6314	Vertical Fin
HCAA6316	Wing Struts
HCAA6317	Landing Gear
HCAA6318	Brushless Motor
HCAA6319	8x4 Propeller
HCAA6320	18 AMP ESC
HCAA6321	Servo
HCAA6322	Tail Wheel
GPMM3318	3S LiPo Smart Balancing Charger
TACJ0403	TTX404 2.4 GHz 4-Channel Transmitter
TACL0624	TR624 2.4 GHz 6-Channel Receiver
<b>NOTE</b> 	Full-size plans are not available. You can download a copy of this manual at <a href="http://www.hobbico.com">www.hobbico.com</a> .

## KIT INSPECTION

Before starting to build, inspect the parts to make sure they are of acceptable quality. If any parts are missing or are not of acceptable quality, or if you need assistance with assembly, contact **Product Support**. When reporting defective or missing parts, use the part names exactly as they are written in the Kit Contents list.

**Hobbico Product Support**  
3002 N. Apollo Drive, Suite 1  
Champaign, IL 61822  
Telephone: (217) 398-8970, ext. 5  
Fax: (217) 398-7721  
E-mail: [airsupport@hobbico.com](mailto:airsupport@hobbico.com)

## KIT CONTENTS

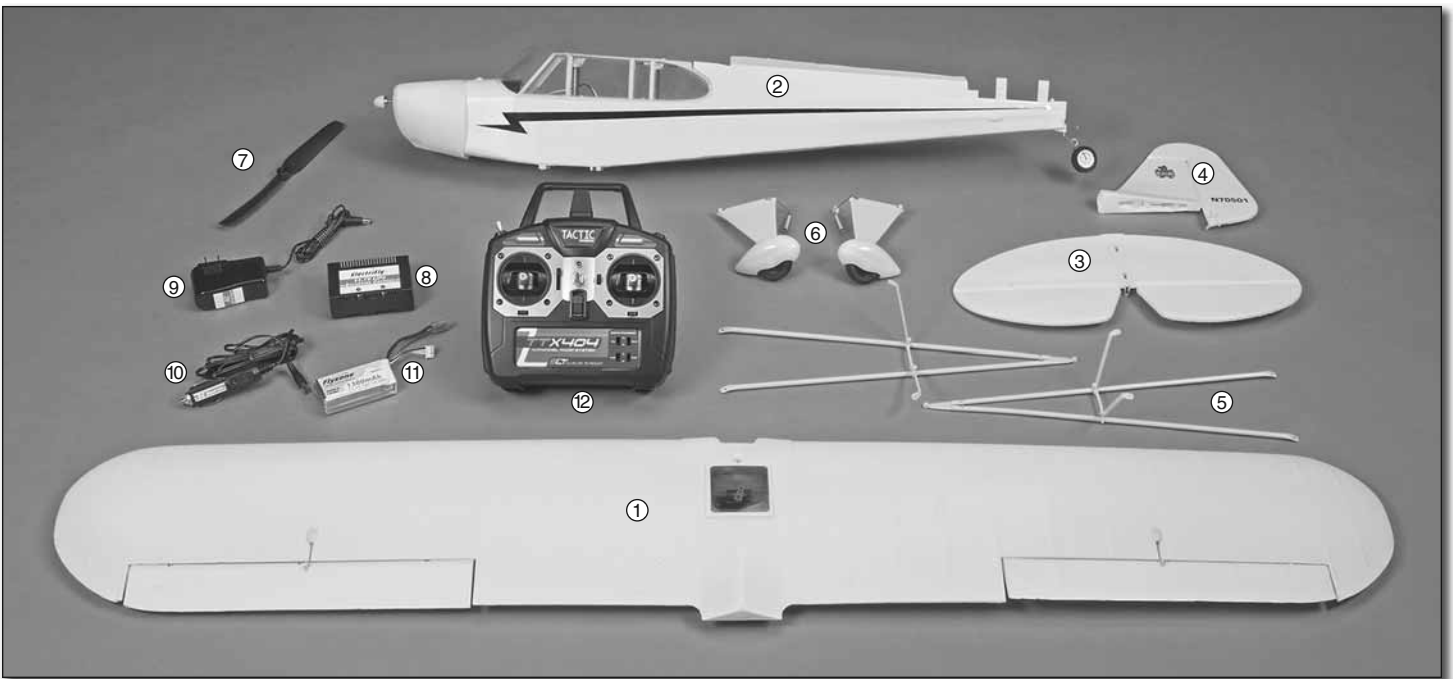

### KIT CONTENTS

1. Wing assembly (aileron servo installed)
2. Fuselage assembly (battery hatch, tail gear, motor, ESC, receiver, elevator servo, rudder servo installed)
3. Horizontal stabilizer assembly (elevator hinged to stab)
4. Vertical stabilizer assembly (rudder hinged to fin)
5. Wing strut assembly (2)
6. R&L landing gear assembly

7. 8.25" Diameter propeller
  8. ElectriFly 3-Cell 11.1V LiPo balancing charger
  9. ElectriFly AC/DC Adapter
  10. Cigarette lighter DC charge adapter
  11. EMAX 1300mAh 11.1V 3S1P 10C LiPo battery (ST connectors)
  12. TX404 Transmitter
- Not shown: (3) wire pushrods with Z-bends on one end

## ASSEMBLE THE MODEL

### Mount the Main Landing Gear

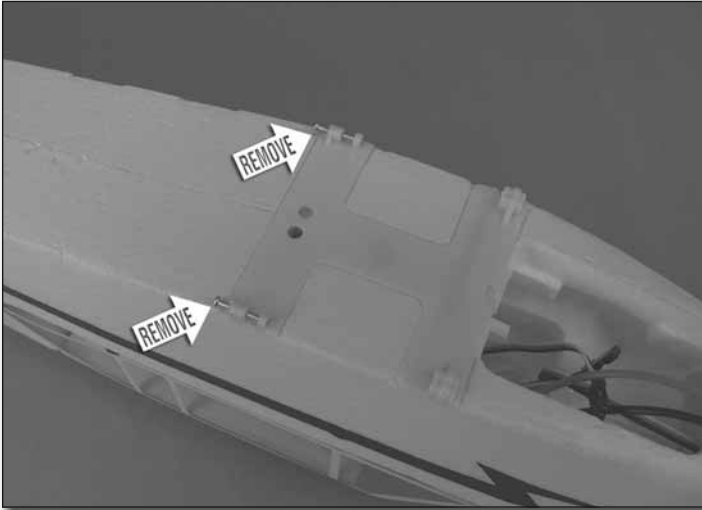

- ❑ 1. Remove the preinstalled 2 x 15mm Phillips screws from the aft landing gear mount on the bottom of the fuselage.

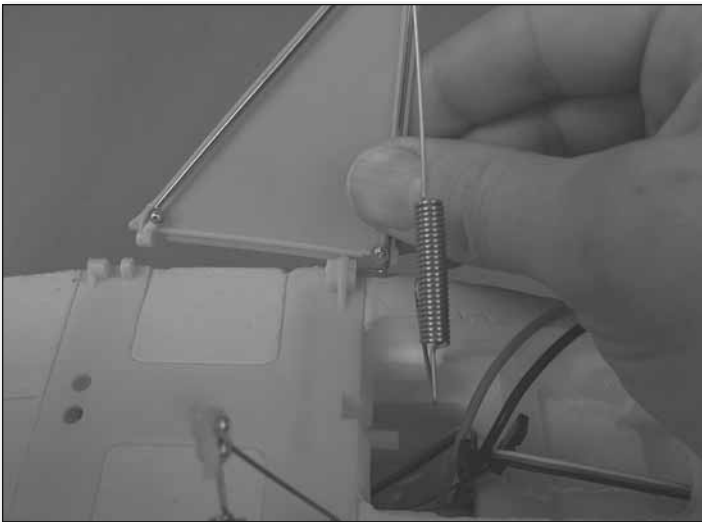

- ❑ 2. Press the landing gear wire in the left main landing gear into the landing gear mount. Then, reinstall the 2 x 15mm

Phillips screw into the aft mount and through the gear, but don't tighten it all the way down yet (the screw will be removed and reinstalled again later when attaching the wing struts). Mount the right main landing gear the same way.

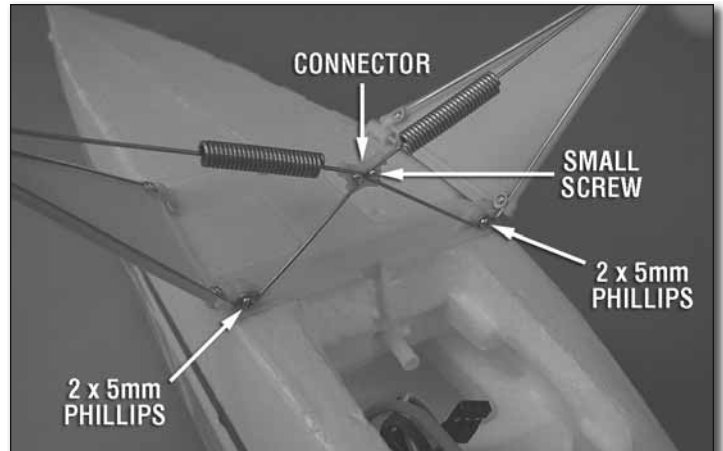

- ❑ 3. Remove the small screw from the plastic landing gear wire connector that is not already holding in the other gear wire. Insert the other landing gear wire into the connector, making sure it is fully seated. Reinstall the screw using care not to over-tighten it. Mount the end of both gear springs to the front, inner mount with 2 x 5mm Phillips screws.

### Mount the Vertical & Horizontal Stabilizers (Fin and Stab)

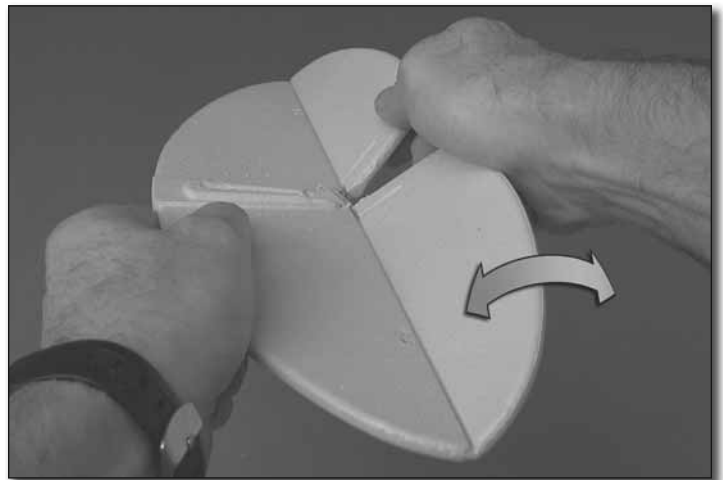

- ❑ 1. Flex the elevators up and down a few times to loosen them up so they move easier.

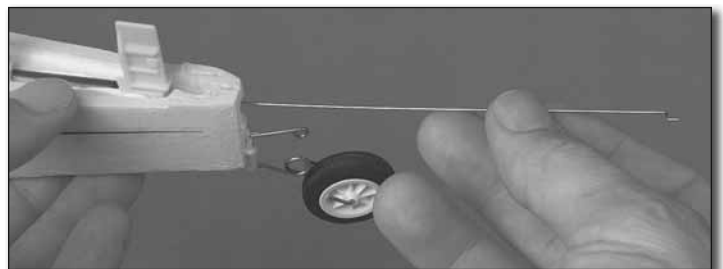

- ❑ 2. Insert one of the pushrod wires part way up through the elevator pushrod guide tube in the fuselage.

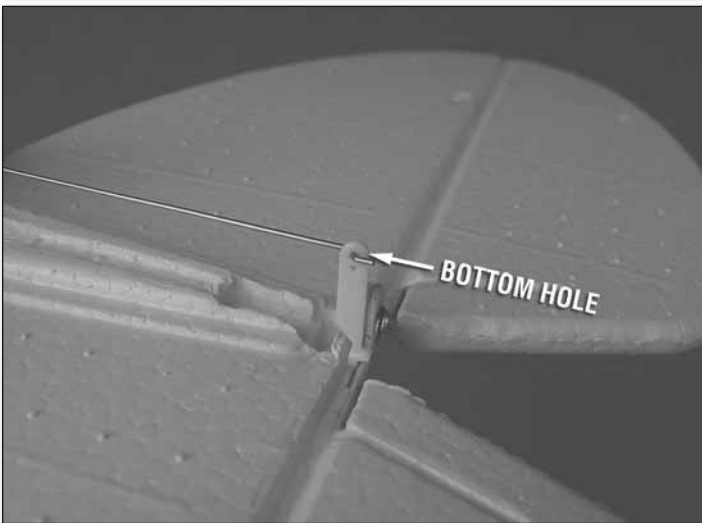
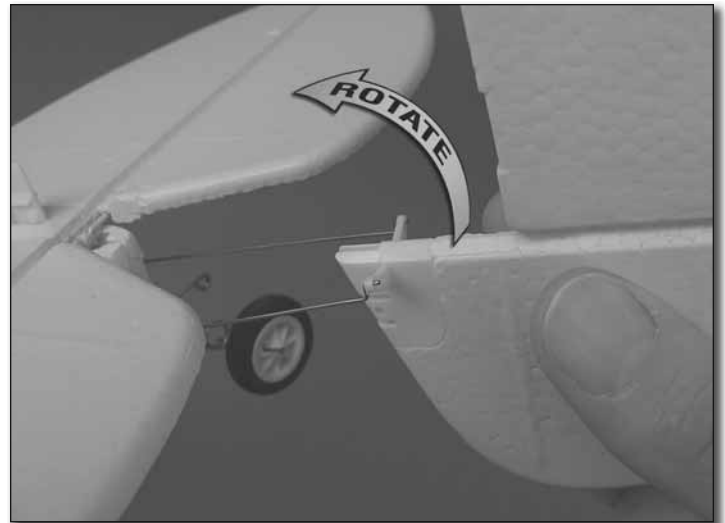
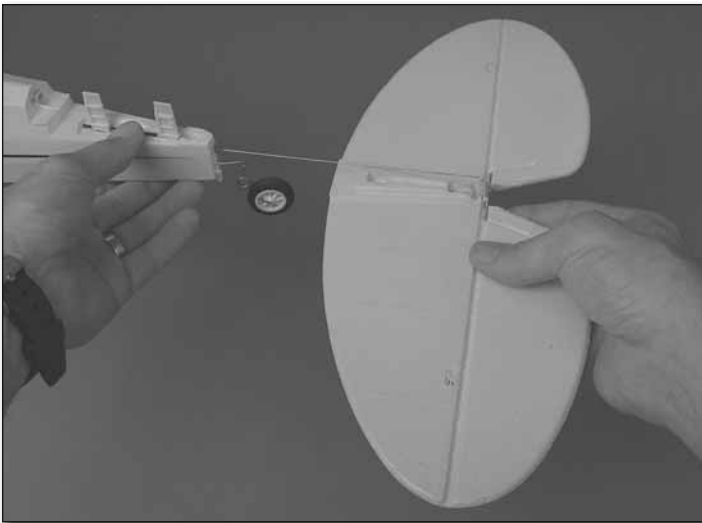

❑ 3. Insert the “Z-bend” of the wire into the **bottom** hole in the elevator horn as shown.

❑ 5. Same as the elevator pushrod, guide the two rudder pushrods partway up through the guide tubes in the fuselage. Connect the pushrods to the outer holes in the rudder horn, then rotate the rudder 90° to lock the pushrods in.

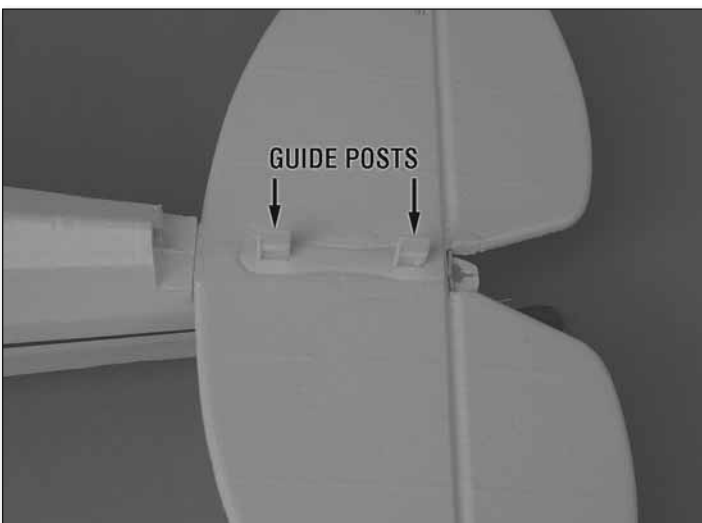

❑ 4. Turn the elevator over and fit it over the molded-in guide posts in the fuselage as you guide the pushrod up through the tube in the fuselage.

❑ 6. Prepare to join the vertical stabilizer assembly to the fuselage by inserting the tail gear wire partway into the rudder.

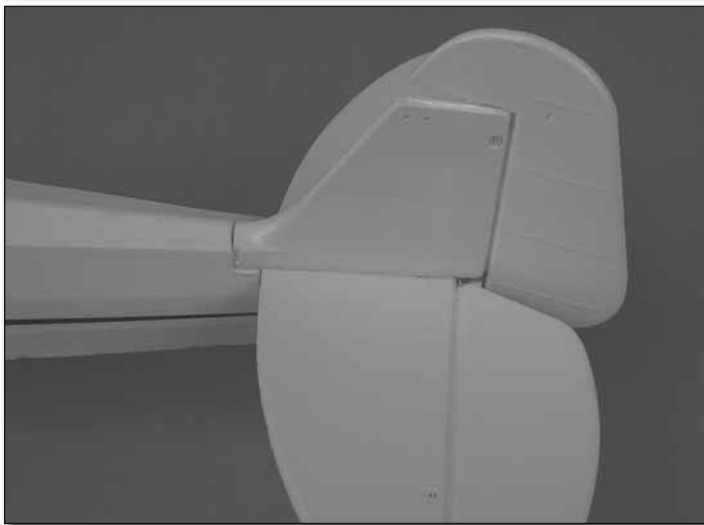

❑ 7. Join the vertical stabilizer (fin) to the fuselage by placing it over the guide posts sticking up through the stab. Pull the rudder forward, locking it into position.

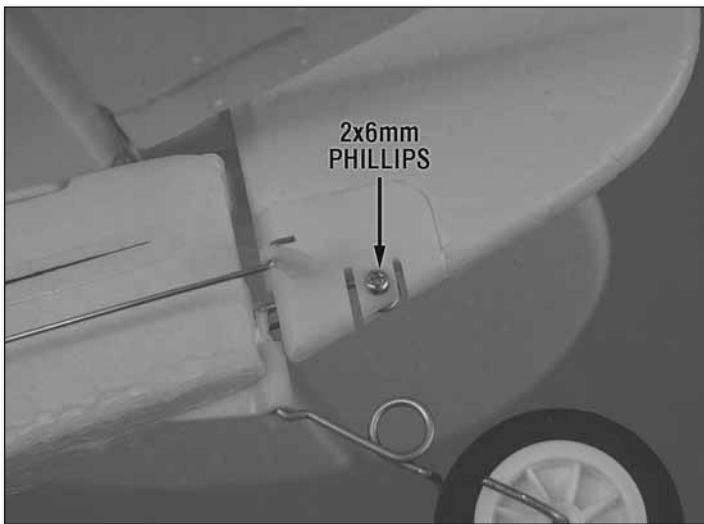

❑ 8. Lock the tail gear into position with a 2 x 6mm Phillips screw.

## Hook Up the Controls

❑ 1. If you haven't yet done so, familiarize yourself with the included Tactic™ 404 radio control system included with this Cub by reading the separate included instruction manual.

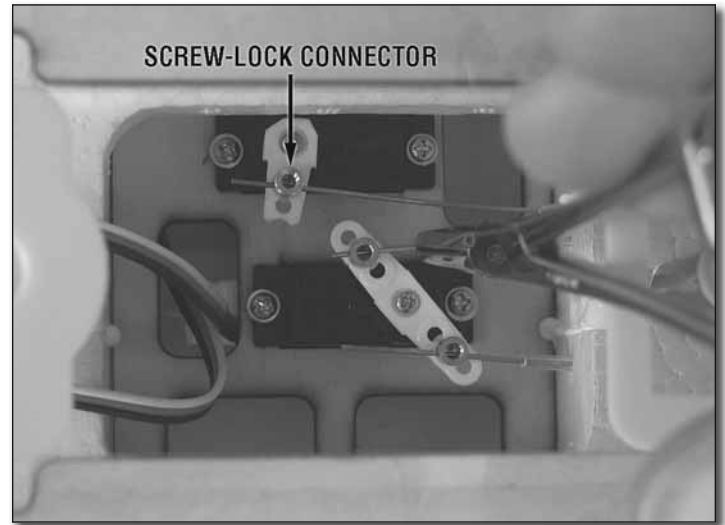

❑ 2. Use needle-nose pliers or hemostats to guide the pushrod wires into the screw-lock connectors on the elevator and rudder servo arms—if necessary you can rotate the servo arms to get the pushrods in.

**CAUTION:** Perform the following steps **without** the propeller mounted to the motor. Do not mount the propeller until instructed to do so.

❑ 3. Move the throttle stick all the way down and center all the trims on the transmitter (except for the throttle trim which should be all the way down). Turn on your transmitter and connect the included battery pack to the battery wire coming from the ESC (electronic speed control) in the fuselage. When the connection is made you will hear one or two beeps coming from the ESC. **IMPORTANT:** The beeping sound alerts you that the system has power and the motor is “armed.” This means whenever the throttle control stick is advanced the propeller will turn. So later, when the propeller is mounted and you are ready to fly, **keep clear of the propeller while handling the model** and do not inadvertently advance the throttle stick. If you do, the propeller will turn and damage or injury could be caused.

❑ 4. Make sure the motor brake function in the ESC is deactivated. When you advance the throttle stick the motor should turn and when you bring the throttle stick all the way back down the motor should come to a coasting stop. If the motor stops abruptly this means that the brake is on. To turn off the brake, disconnect the motor battery, but leave the transmitter on. Advance the throttle stick and throttle trim all the way. Reconnect the battery and listen for one beep. Bring the throttle stick and the throttle trim all the way back down and listen for another single beep. Now the motor brake function is turned off.

The procedure for turning on the motor brake is the same with the exception that two beeps will sound when the brake is being armed.

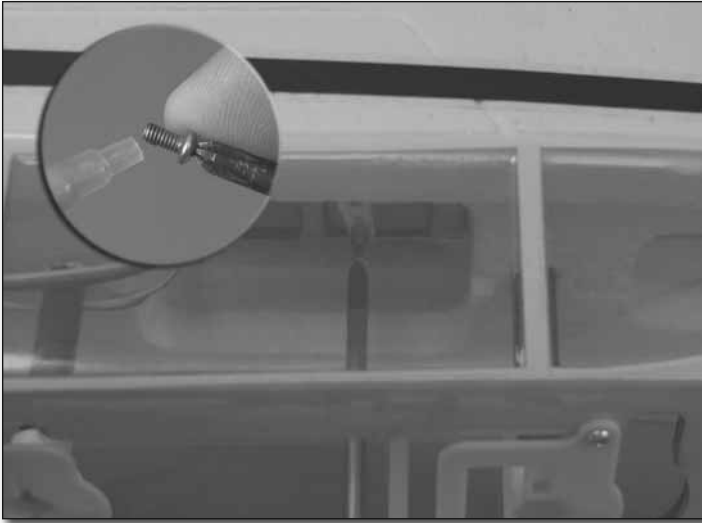

❑ 5. Add a **tiny** drop of threadlocker to the 2.5mm x 5mm Phillips screws and install them into the screw-lock connectors on the elevator and rudder servos, but don't tighten them down yet. If you have difficulty getting the screws in, it may be easier to hold your screwdriver upright and hold the fuselage upside-down. This way the screws won't fall off the screwdriver.

❑ 6. With the elevator and rudder centered, use hemostats or needle-nose pliers to hold the screw-lock connectors while tightening the screws to lock the pushrods down.

### 4-CHANNEL RADIO SET UP (STANDARD MODE 2)

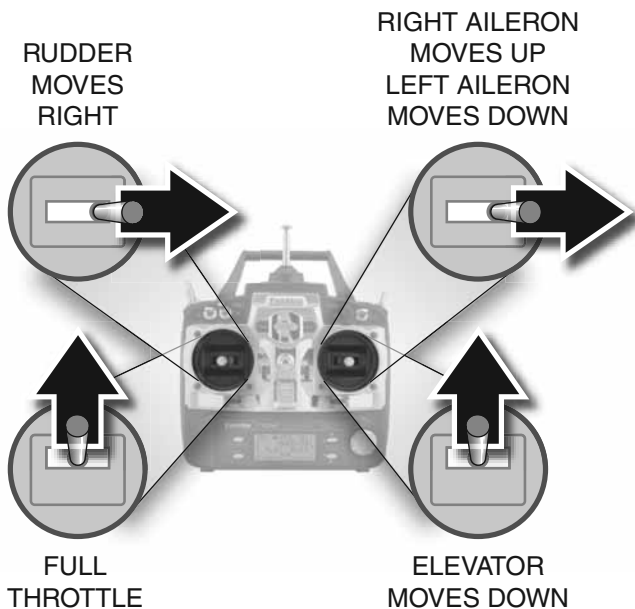

❑ 7. Move the sticks on the transmitter and make sure all the controls respond in the correct direction. If any of the controls do not respond in the correct direction use the servo reversing function in the transmitter to reverse any of the controls necessary.

### Check the Control Throws

One major factor that determines how any plane handles in the air is the control surface throw, or how far each control surface (aileron, elevator and rudder) moves up and down or left and right. If the throw is too much, the plane will respond too quickly. If the throw is too little, the plane will respond too slowly. The control throws in your Cub have already been determined by where the pushrods are connected to the servo arms and control surfaces and how far the servo arms rotate. But if you're using a radio control system different than the one recommended, the servo arms could rotate more or less than anticipated, changing the throws. Therefore, it's a good idea to double-check the throws just to make sure they are acceptable. Follow the procedure below to make sure the control throws are properly set.

#### Measure the elevator throw first:

❑ 1. Use a small box or something similar to prop up the aft end of the fuselage so the stab will be level (or nearly level).

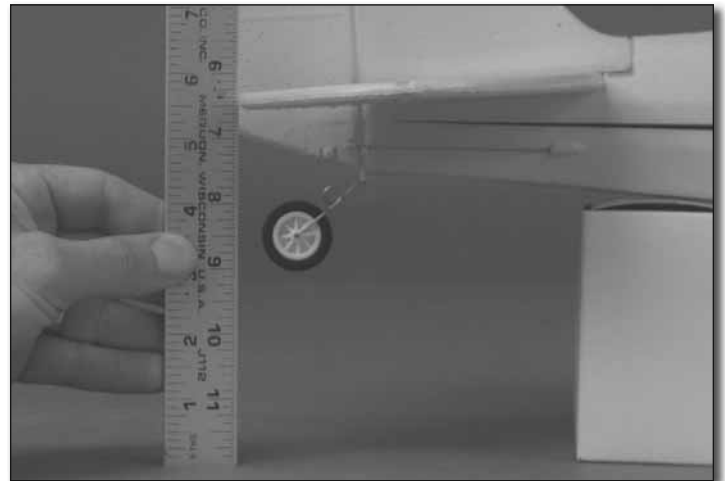

❑ 2. Still without the propeller mounted to the motor, turn on your transmitter and connect the battery. Place a ruler to the trailing edge of the elevator at the widest part (from front-to-back).

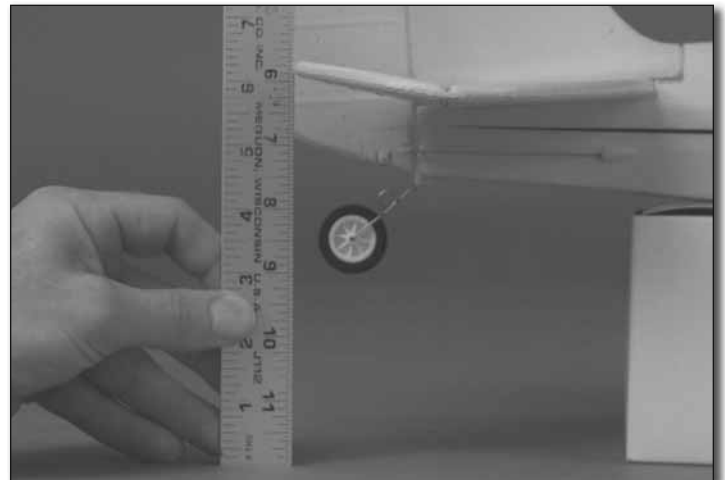

❑ 3. Use your transmitter to move the elevator up and measure the distance it moved from center. This is your "up" control throw. Measure the down elevator control throw the same way.



Compare your up and down elevator throw to the recommended elevator throw below. Measure and compare the rudder and aileron throws as well.

These are the recommended control surface throws:					
ELEVATOR		RUDDER		AILERONS	
Up	Down	Right	Left	Up	Down
3/8"	3/8"	1-1/4"	1-1/4"	1/2"	1/2"
[9.5mm]	[9.5mm]	[32mm]	[32mm]	[12.7mm]	[12.7mm]
9°	9°	30°	30°	17°	17°

*Note: If you ever install different servos in the plane or use a different radio control system, make sure you set it up so you will have the recommended throws.*

This should be the new elevator throw:	
ELEVATOR (EXPERT)	
Up	Down
5/8"	5/8"
[15.9mm]	[15.9mm]
14°	14°

### Increased Elevator Throw for Expert Pilots (Optional)

Pilots who have mastered flying their Piper Super Cub with the recommended control throws, or pilots who are already experienced, may increase the elevator throw as shown below for even more maneuverability.

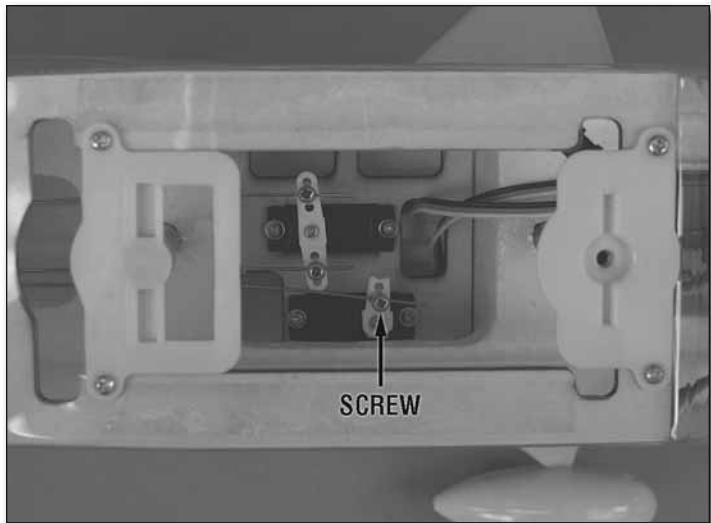

1. Loosen the screw in the screw-lock connector on the elevator servo arm and remove the screw in the servo arm. Remove the elevator servo arm from the elevator servo.

2. Remove the retainer, then switch the screw-lock connector from the inner hole to the outer hole. Replace the retainer on the screw-lock connector, then replace the servo arm on the servo with the screw. Center the elevator the same way you did before with the radio on and tighten down the screw in the screw-lock connector to lock the pushrod down.

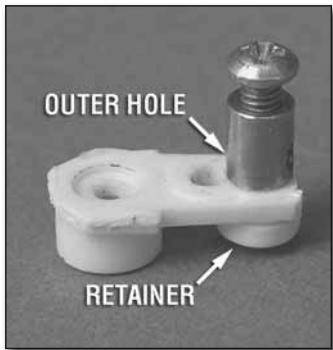

### Mount the Wing

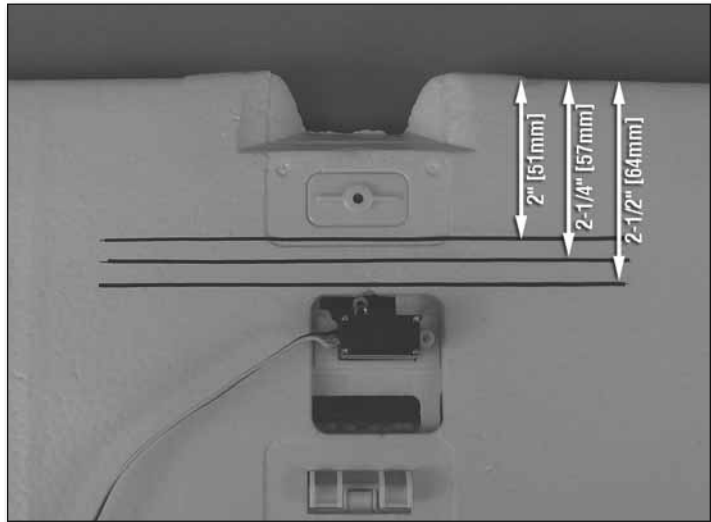

1. For balancing the model later, use a fine-point felt-tip pen to mark three balance lines across the bottom of the wing 2" [51mm], 2-1/4" [57mm] and 2-1/2" [64mm] back from the leading edge. The line in the middle is the recommended starting balance point and the forward and aft lines mark the forward and aft balance points.

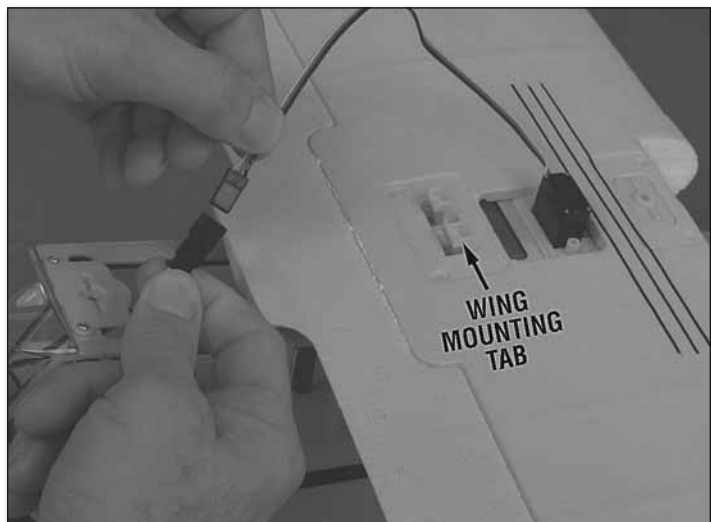

2. Connect the aileron servo wire to the aileron servo extension coming from the receiver.

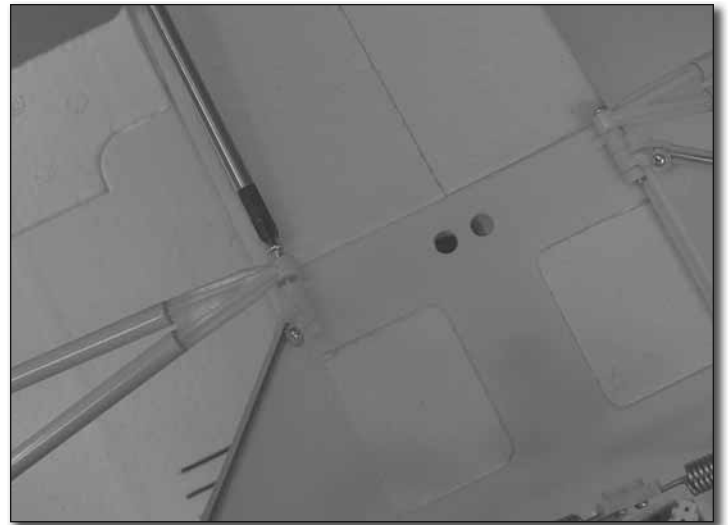
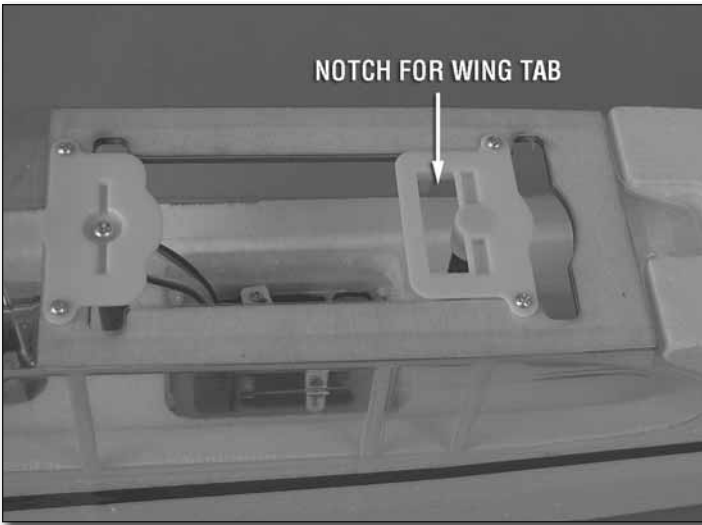

❑ 5. Turn the airplane over. Remove the 2 x 15mm screws that are holding in the rear of the landing gear and mount the ends of the struts with the screws.

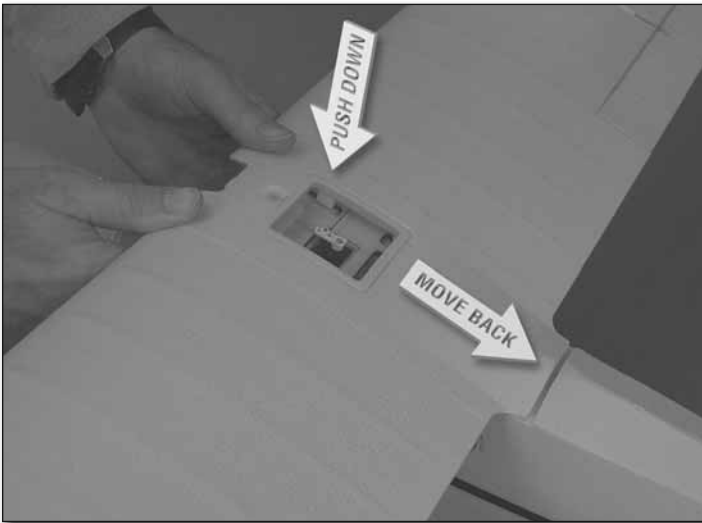

❑ 3. Turn the wing over. Making sure the aileron servo wire doesn't get caught between the bottom of the wing and the top of the fuselage, key the tab in the wing into the notch just ahead of the aft mounting post. Push the top of the wing down and back to lock it in.

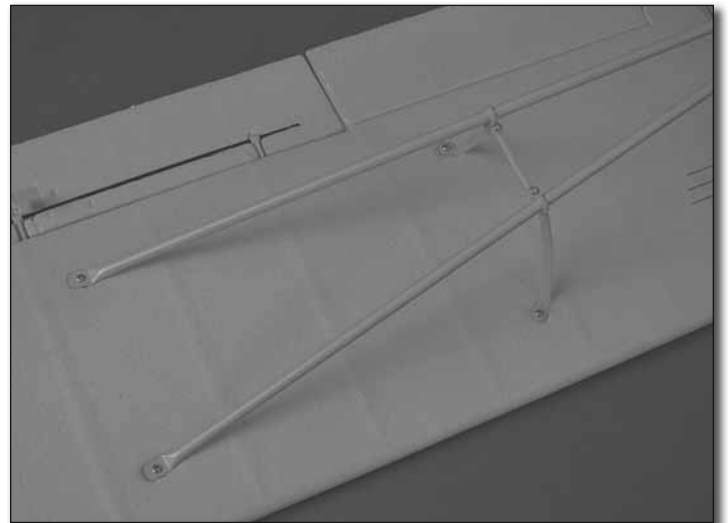

❑ 6. Fasten the struts and strut braces to the wing with 2 x 8mm Phillips screws.

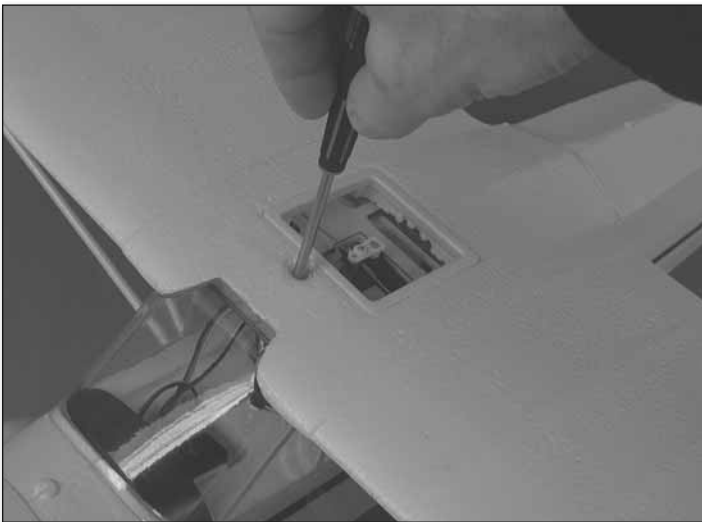

❑ 4. Fasten the wing to the fuselage with a 3x10mm Phillips screw.

## FINAL PREPARATION

### Mount the Propeller

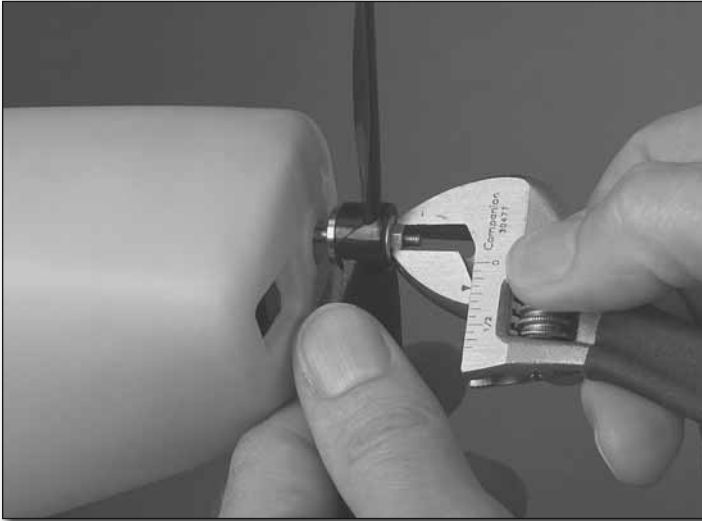

1. Mount the propeller to the propeller shaft with the washer, nut and a **tiny** drop of threadlocker on the threads. Tighten the nut with your fingers until it is snug against the washer. Then, use a small crescent wrench to tighten the nut securely. Sometimes, as you tighten the nut, the propeller shaft turns with it causing the nut not to tighten. But if you turn the nut quickly, it should tighten after another turn or two.

*For future reference, if you ever need to remove the propeller later, needle-nose pliers may be required to hold the propeller hub behind the propeller to keep the shaft from turning.*

2. Install the propeller spinner by pressing it over the propeller shaft.

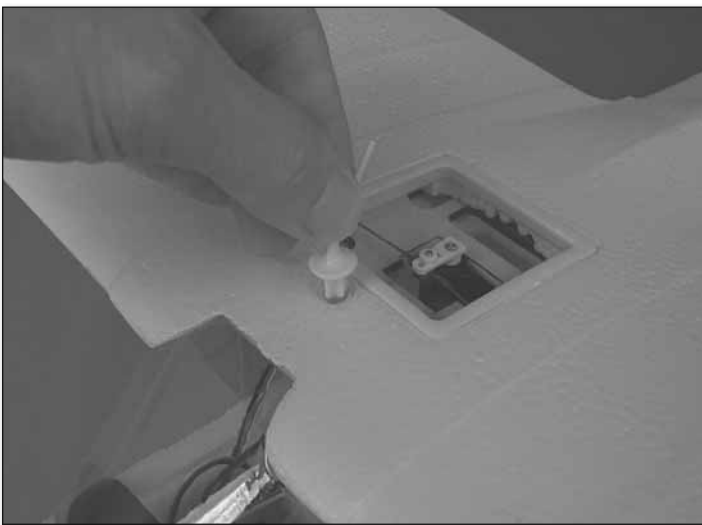

3. Insert the replica antenna into the hole for the wing bolt in the top of the wing.

### Check the C.G. (Center of Gravity)

The C.G. (Center of Gravity) is the location on the wing where the model balances and has a great effect on how it will fly. If the C.G. is too far aft (tail heavy), the model will be too responsive. If the C.G. is too far forward (nose-heavy), the model will not be responsive enough. As provided to you, your Piper Super Cub should already be properly balanced, or very nearly properly balanced, but it's a good idea to check the balance just in case. Follow the instructions to make sure the model is balanced properly and the C.G. is in the correct location.



1. Install the motor battery, but do not connect it to the ESC. Also install the battery hatch. All the rest of the parts of the model should already be installed including the propeller, propeller spinner and the wing struts.



□ 2. You have already marked the balance lines on the bottom of the wings. Now place your fingers on the **middle** balance line and lift the model. The fuselage should remain level—it may be helpful to have an assistant view the model from the side to see. If the fuselage does not rest level try moving your fingers under the wing **making certain to keep them between the forward and aft lines**. As long as the fuselage is level with your fingers between the lines the balance range is acceptable and the model is ready to fly. However, even if after moving your fingers all the way to the forward lines the nose remains low, tail weight will be required. Or, even if after moving your fingers all the way to the rear lines the tail remains low, nose weight will be required. Balance the model as instructed below.

**Note:** Even if your Cub balances perfectly on the recommended balance point, later you may wish to change its flying characteristics by moving the C.G. forward or aft. Moving the C.G. forward (nose heavy) will make the model more stable which may be better for windier days, but this will also make it less maneuverable. Moving the C.G. back (tail heavy) will make the Cub more maneuverable which is good for experienced pilots who wish to perform aerobatics. In any regard, start at the recommended balance point and never fly the model with the C.G. outside of the recommended range.

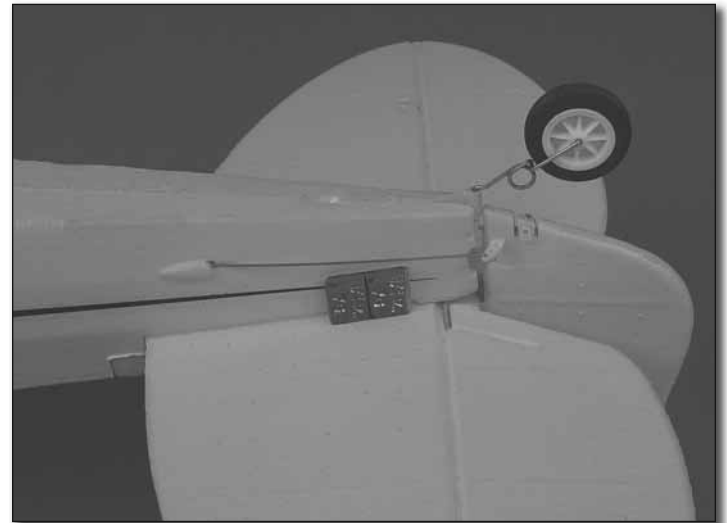

□ 3. Determine the amount of weight required by placing segments of Great Planes stick-on lead (GPMQ4485) (or similar) over the cowl or tail where shown, but do not attach it yet.



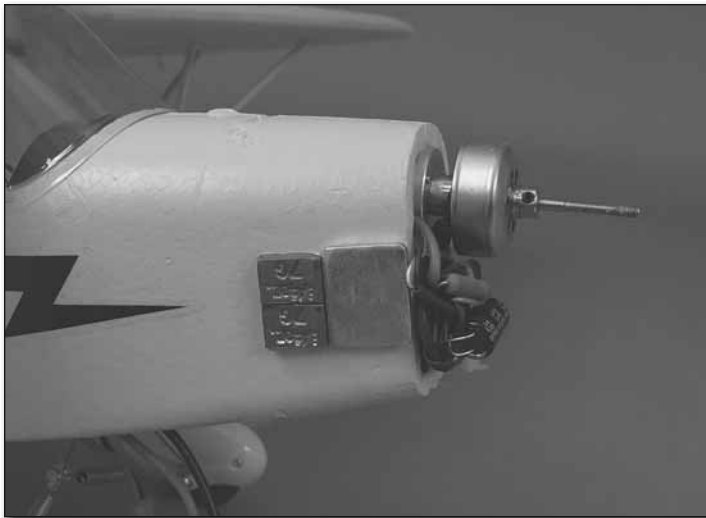

❑ 4. Once you can get the model to balance and you know how much lead will be required, permanently stick it into position. The best place to add nose weight is to the side of the fuselage just behind the weights that are already there. This will require removing the propeller, then the propeller hub (by holding the shaft with pliers) and then the cowl. Attach the lead, then replace the cowl, propeller and spinner. If tail weight is required, simply attach it to the side of the fuselage under the horizontal stab where shown.

❑ 5. Recheck the C.G. to make certain the model still balances where required. Once finished, remove the battery. Never charge the battery while it is installed in the model.

❑ 6. Later, once you become an expert at flying your Cub, you may change the flying characteristics by changing the balance point—but do not go beyond the marks you made on the bottom of the wing. Moving the C.G. forward (nose heavy) will improve the model's stability. This could be an advantage on breezy days. Moving the C.G. aft (tail heavy) will make the model more responsive.

## GET THE MODEL READY TO FLY

### Identify Your Model

No matter if you fly at an AMA sanctioned R/C club site or if you fly somewhere on your own, you should always have your name, address, telephone number and AMA number on or inside your model. It is **required** at all AMA R/C club flying sites and AMA sanctioned flying events and simply a “good idea” even if flying somewhere else. Write this information on a strip of masking tape and place it on the inside of the battery hatch (or simply write the information directly on the battery hatch).

## Battery Charging Precautions

Be certain to refer to the instructions that accompany the charger to properly and safely charge the battery. Also read and follow the battery charging precautions that follow.

- Be careful to avoid overcharging the battery!
- Remember to check the temperature of the battery during the charge. The batteries should not get hot. If they do, unplug them from the charger.
- If you use a different battery charger, charge the battery pack that came with this Cub at a maximum charge rate of 1C (1 x capacity or 1300 mAh (1.3Ah)). A higher rate will charge the battery pack too quickly possibly causing damage or a fire.
- A properly cared for battery pack will last a long time. If the battery pack is continually overcharged or charged at too high of a rate, the life of the battery pack will be shortened.

**WARNING:** Misuse or malfunction may overheat the battery and charger, resulting in personal injury or damage to surroundings.

## Battery Recycling

**ATTENTION:** The product you have purchased is powered by a rechargeable battery. At the end of the battery's useful life, under various state and local laws, it may be illegal to dispose of this battery into the municipal waste system. Check with your local solid waste officials for details in your area for recycling options or proper disposal. We encourage contacting your local recycling center for more information.

## FLYING THE PIPER Super CUB

Although the Piper Super Cub has the configuration of a trainer (a high wing), due to its small size and lack of self-correcting features it is not necessarily intended for beginners. The Cub is, however, easy to fly even for pilots with moderate experience. If you have not previously flown a trainer it is strongly suggested that you learn to fly with one first. Or, get the assistance of an experienced pilot to help you with the first few flights.

## Find a Suitable Flying Site

Find a flying site clear of buildings, trees, power lines and other obstructions. Until you know how much area will be required and have mastered flying your Cub in confined spaces, a site at least the size of two or three football fields should be adequate—a flying field specifically intended for R/C planes is best. Don't fly within five miles of R/C flying fields and never fly near people—especially children who can wander unpredictably.

## Perform a Range Check

As a precaution, an operational *ground range test* should be performed before the first flight each time you go out. Performing a range test is a good way to detect problems that could cause loss of control such as low batteries, defective or damaged radio components or radio interference. This usually requires an assistant and should be done at the actual flying site you will be using.

First turn on the transmitter, then install the fully-charged battery into the fuselage. Connect the battery and install the hatch.

**Remember, use care not to “bump” the throttle stick. Otherwise, the propeller will turn and possibly cause damage or injury.**

Follow the instructions that came with your radio control system to perform a ground range check. Make sure you operate the motor and vary the rpm while performing the check. Have your assistant alert you if the controls quit responding or move suddenly or erratically.

If the controls aren't working correctly or if anything seems wrong, don't fly the model until you find and correct the problem. Make certain all the servo wires are securely connected to the receiver and that the transmitter batteries are in good condition.

## Monitor Your Flight Time

Monitor and limit your flight time using a timer (such as one on a wrist watch or in your transmitter if yours has one). When the batteries are getting low you will usually notice a performance drop before the ESC cuts off motor power, so when the plane starts flying slower you should land. Often (but not always), power can be briefly restored after the motor cuts off by holding the throttle stick all the way down for a few seconds.

To avoid an unexpected dead-stick landing on your first flight set your timer to a conservative 7 minutes (in most conditions the Super Cub will usually fly for approximately 9 minutes, but this can vary). When your alarm sounds you can either land right away, or if you are an experienced pilot you may continue to fly until the motor finally quits. Then, glide it in for a landing. If planning a “dead-stick,” circle your Cub upwind of the landing area until the motor quits and note the run time.

When you learn how much flight time you are getting you can adjust your timer accordingly. Always be conservative so the motor won't quit unexpectedly and you will have enough battery to land under power.

## Take Off

**Until you have become comfortable flying your Super Cub, do not fly if the wind speed is greater than 10mph [16kph].**

One final check before takeoff: **always check the flight control response to your inputs from the transmitter before every flight.** Be certain the ailerons, elevator, rudder and throttle respond correctly and that none of the controls have inadvertently become reversed.

Your Cub may takeoff from short grass or pavement. For beginners, short grass is usually best because it stabilizes the wheels making it easier to keep the plane rolling straight ahead. If the grass is too tall the Cub may also be hand-launched.

### ROG (Rise off Ground)

Place the model on the ground with the nose pointing directly into the wind—taking off into the wind reduces the ground speed required for takeoff and helps stabilize the plane keeping it moving straight ahead. Smoothly but rapidly advance the throttle using the left control stick (rudder) to keep the Cub going straight and the right control stick (ailerons) to keep the wings level. Once the plane becomes “light” smoothly apply just enough “up” elevator to allow the model to rise into the air—all this will happen in a few seconds. Do not “yank” up on the elevator stick—rather, be smooth and allow the plane to establish a gentle climb

### Hand-Launch

It's easy to hand-launch your Piper Cub, but it's even easier to have an assistant launch it—especially for the first time.

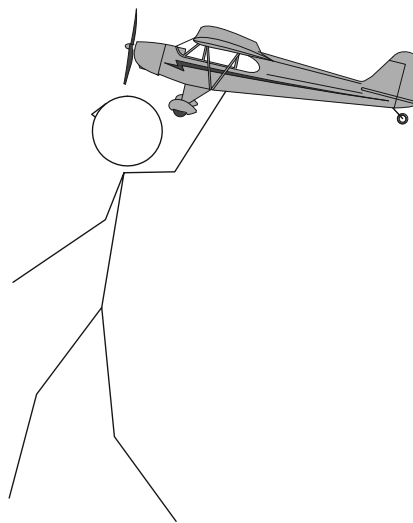

Have your assistant hold the model under the fuselage behind the landing gear. When you have signaled “ready” and your assistant has acknowledged, advance the throttle to full power. The Cub should pretty much fly out of his hand, but it's a good idea to give it a strong toss at a slightly nose-up attitude. Remind your assistant to do his best to launch the Cub with the wings level. The Cub will initially ascend, then climb once it gains enough flying speed. Apply “up” elevator to start climbing and use the ailerons to keep the wings level.

## Flying

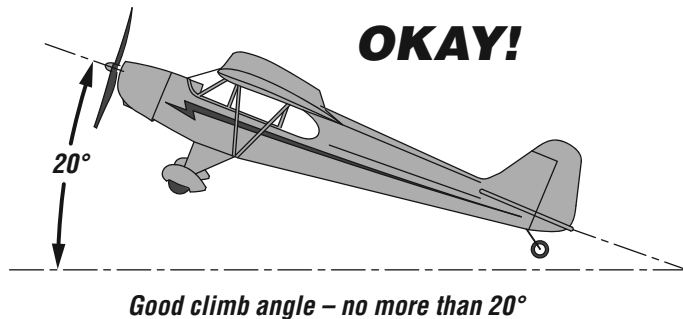
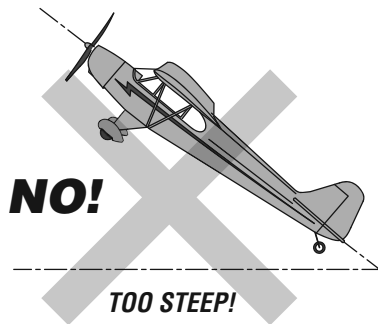

Once the Cub has become airborne, establish a gentle climb at an approximately 20°-30° angle. Continue climbing and keeping the wings level until the Cub has reached an altitude of approximately 100' [30m] when you can make your first turn away from yourself.

If you already have some flight experience and are relatively comfortable flying your Cub, the first thing you should do is use the trims to adjust the flight controls so the plane will fly straight-and-level when the control sticks are centered.

If you find yourself in a little over your head and are having difficulty controlling your Cub, your first priority will be simply to keep the model airborne. Concentrate on making smooth turns by using the ailerons to bank the wings and the elevator to control pitch. It may also be a good idea to throttle back some to slow the Cub as well.

One thing for beginner pilots to keep in mind is that when the plane is flying away from you, moving the aileron stick to the right will make the plane bank to your right. However, when the model is flying toward you, moving the aileron stick to the right will make the plane move to your **left**. Of course, the plane is still responding the same way, it's just that your orientation is reversed. This must be kept in mind while learning to fly (and is also a good reason to take flight lessons from an experienced pilot!).

To establish a turn, "up" elevator (pulling back on the stick) is usually required along with aileron input to get the model into a bank. To stop the turn, apply a small amount of opposite aileron.

Remember to keep the model high enough to give yourself time to make corrections, but don't let it get too far away. Otherwise, it will be difficult to tell what the plane is doing and where it is going. Continue to fly your Cub, getting used to how it responds before finally coming in to land.

One final check before landing: see how the model will react when you cut the power. While at altitude, cut the motor power. The model should establish a gentle, downward glide path. This is how it will react when it's actually time to land. Add power and climb back to your original altitude. Practice a few of these "climb and glides" to judge how your Cub react.

## Landing

To land, fly down-wind past the landing area. Gently turn into the wind and reduce the throttle so that the airplane initiates an ascending glide path. If necessary, add power to extend the glide path to reach the runway. As the model approaches and loses altitude, gradually and proportionally, add "up" elevator to control the glide path and altitude. Continue to apply elevator until the model touches down, at which time you should be holding full, or nearly full up elevator. This will cause the airplane to slow and settle to the ground.

**Caution: If, during a rough landing, the propeller becomes jammed and cannot rotate, the battery and speed control will become very hot. Immediately move the throttle down to stop the motor. If you fail to do this, the motor, speed control and/or battery will be damaged.**

## After Flight

Disconnect the battery and remove it from the airplane. Then turn off the transmitter. Inspect the airplane to make sure nothing has become loose or damaged. Allow the battery to cool before recharging, or allow the motor to cool for a few minutes before installing another battery and flying again.



***Flyzone***<sup>TM</sup>  
how high will you soar