

HOBBISTAR 60™ HOBBISTAR 60 MK III

ASSEMBLY INSTRUCTIONS

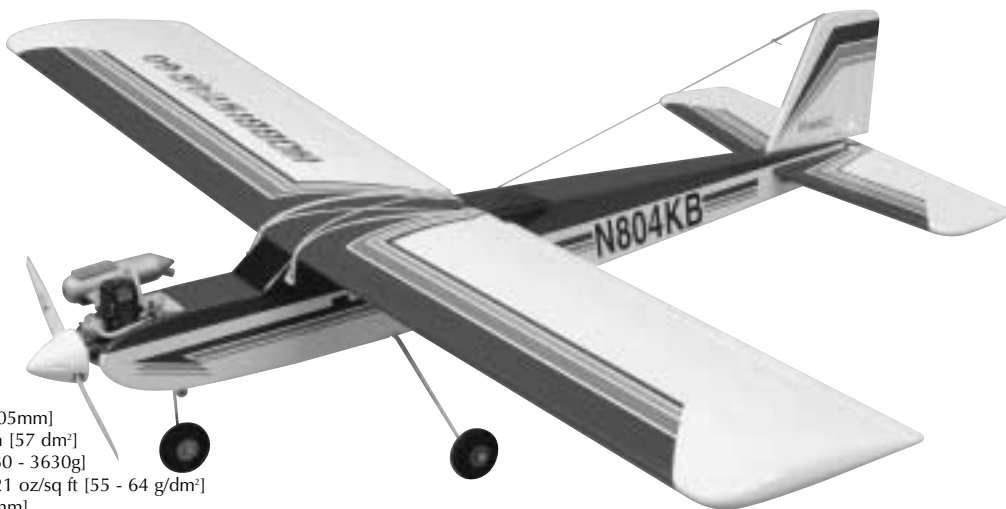

Specifications:

Wingspan: 71 in [1805mm]

Wing Area: 888 sq in [57 dm²]

Weight: 7 - 8 lb [3180 - 3630g]

Wing Loading: 18 - 21 oz/sq ft [55 - 64 g/dm²]

Length: 55 in [1400mm]

Radio: 4-channel with 4 servos

Engine: .60 to .65 cu in [10.0 - 10.6cc] two-stroke

See more of our products at www.hobbico.com

WARRANTY

Hobbico guarantees this kit to be free from defects in both material and workmanship at the date of purchase. This warranty does not cover any component parts damaged by use or modification. In no case shall Hobbico's liability exceed the original cost of the purchased kit. Further, Great Planes reserves the right to change or modify this warranty without notice.

In that Hobbico has no control over the final assembly or material used for final assembly, no liability shall be assumed nor accepted for any damage resulting from the use by the user of the final user-assembled product. By the act of using the user-assembled product, the user accepts all resulting liability.

If the buyer is not prepared to accept the liability associated with the use of this product, the buyer is advised to return this kit immediately in new and unused condition to the place of purchase.

READ THROUGH THIS MANUAL BEFORE STARTING CONSTRUCTION. IT CONTAINS IMPORTANT INSTRUCTIONS AND WARNINGS CONCERNING THE ASSEMBLY AND USE OF THIS MODEL.



1610 Interstate Drive
Champaign, IL 61822
(217) 398-8970, Ext. 2
airsupport@hobbico.com

Table of Contents

INTRODUCTION.....	2
SAFETY PRECAUTIONS.....	3
ADDITIONAL ITEMS REQUIRED.....	3
Radio system	3
Engine	3
Tools, Building Supplies, Accessories.....	4
Optional Supplies and Tools	4
Field Equipment.....	4
KIT INSPECTION	5
ORDERING REPLACEMENT PARTS.....	6
TIGHTEN THE COVERING.....	7
PREPARATIONS	7
ASSEMBLE THE WING	8
Join the ailerons.....	8
Join the wing	9
ASSEMBLE THE FUSELAGE.....	10
Mount the stabilizer and fin.....	10
Mount the landing gear	13
Mount the engine	14
Install the fuel tank	15
Mount the aileron servo.....	15
Hook up the controls.....	16
Mount the muffler, prop and spinner	19
PREPARE THE MODEL FOR FLYING	20
Balance the model (C.G.)	20
Center the servos	21
Check the control directions.....	22
Center the control surfaces	22
Adjust the throttle	23
Set the control throws.....	23
Identify your model	24
Balance Propellers	24
Checklist.....	25
Charge the batteries.....	25
Gather your tools.....	25
FLIGHT PREPARATION.....	25
Check the controls.....	25
Range check	26
Ground check.....	26
ENGINE SAFETY PRECAUTIONS	26
AMA SAFETY CODE.....	27
FLYING.....	27
Taxiing	Back Cover
Takeoff	Back Cover
Flight.....	Back Cover
Landing.....	Back Cover
MAINTENANCE TIPS.....	Back Cover

Introduction

Congratulations and thank you for purchasing the Hobbico Hobbistar .60 MKIII. You've made the right decision by purchasing a "real" model airplane that uses a .60-size engine and a 4-channel radio. Once assembled and set up, there will be no fiddling with a temperamental engine or constant troubleshooting to figure out how to get the model to fly. Under the guidance of a flight instructor, all you'll have to do is concentrate on learning to fly. And after you've mastered the Hobbistar, the engine and radio may be installed in your next model!

IMPORTANT:

The **best** thing you can do to insure success is to **find a flight instructor** who will inspect your model for airworthiness and provide flying lessons. It cannot be stated **strongly** enough that, if you do not already know how to fly an R/C airplane, you will probably **not** be able to fly this model by yourself. It may appear to be easy, but over-controlling and disorientation quickly overcome inexperienced fliers swiftly ending their first flight. If you haven't yet done so, **contact the local hobby shop and ask them to introduce you to an instructor or an R/C club representative**. If there is no club or experienced R/C pilot nearby, it would be worth even a long drive to find one-if only for just a few flight lessons (then you'll have an idea of what to expect).

If there is no hobby shop in your area, contact the AMA (Academy of Model Aeronautics), the governing body of model aeronautics. The AMA can direct you to the closest R/C club whose membership should have qualified flight instructors. With the added benefit of insurance coverage provided by the AMA, most clubs require AMA membership to fly at their field.

Academy of Model Aeronautics

5151 East Memorial Drive

Muncie, IN 47302-9252

Tele. (800) 435-9262

Fax (765) 741-0057



Or via the Internet at: <http://www.modelaircraft.org>

*Protect Your Model, Yourself & Others
Follow these Important
Safety Precautions*

1. Your Hobbistar .60 MKIII should not be considered a toy, but rather a sophisticated, working model that functions very much like a full-size airplane. Because of its performance capabilities, the Hobbistar .60 MKIII, if not assembled and operated correctly, could possibly cause injury to yourself or spectators and damage to property.
2. You must assemble the model **according to the instructions**. Do not alter or modify the model, as doing so may result in an unsafe or unflyable model. In a few cases the instructions may differ slightly from the photos. In those instances the written instructions should be considered as correct.
3. You must take time to **build straight, true and strong**.
4. You must use an R/C radio system that is in first-class condition, and a correctly sized engine and components (fuel tank, wheels, etc.) throughout the building process.
5. You must correctly install all R/C and other components so that the model operates correctly on the ground and in the air.
6. You must check the operation of the model before **every** flight to insure that all equipment is operating and that the model has remained structurally sound. Be sure to check clevises or other connectors often and replace them if they show any signs of wear or fatigue.
7. If you are not already an experienced R/C pilot, you should fly the model only with the help of a competent, experienced R/C pilot.

We, as the kit manufacturer, provide you with a top quality kit and instructions, but ultimately the quality and flyability of your finished model depends on how you build it; therefore, we cannot in any way guarantee the performance of your completed model, and no representations are expressed or implied as to the performance or safety of your completed model.

Items Required

These are the items not supplied with the Hobbistar .60 MKIII that must be purchased separately. Where appropriate, order numbers are provided in parentheses.

RADIO SYSTEM



A 4-channel radio control system with four servos is required to fly the Hobbistar .60 MKIII. 4 “channels” means that the radio is capable of operating four controls. On a trainer model such as the Hobbistar the controls are the ailerons, elevator, throttle and rudder. Some 4-channel radio control systems include only three servos, so a fourth servo may have to be purchased separately.

ENGINE



A .60 to .65 cu in two-stroke model airplane engine is required to fly the Hobbistar .60 MKIII. Basically, there are two types of two-stroke engines; “ball bearing” and “non ball bearing” engines. In addition to having a crankshaft supported by two ball bearings, most ball bearing engines have other performance features that boost power and RPM (and price). For the Hobbistar .60 MKIII, an economical, non ball bearing engine is more than suitable. Should you decide to go “all-out” and

purchase a more powerful ball bearing engine anyway, you'll have to remember to throttle back to slow the model while learning to fly. A suitable propeller and spare propellers will also be required (most two-stroke .60 engines run well with a 12 x 6 or 11 x 7 propeller, but refer to the recommendations in the instructions that came with the engine).

TOOLS, BUILDING SUPPLIES AND ACCESSORIES

These are the rest of the items required to assemble the Hobbistar .60 MKIII.

- 6" [150mm] servo extension (HCAQ2701 for Futaba®)
- R/C foam rubber (1/4" [6mm] - HCAQ1000, or 1/2" [13mm] - HCAQ1050)
- Medium silicone fuel tubing (GPMQ4131)
- #64 rubber bands (1/4 lb [113g] box, HCAQ2020)
- Stick-on segmented lead weights (GPMQ4485)
- Threadlocker thread locking cement (GPMR6060)
- 1/2 oz. [15g] Thin Pro™ CA Glue (GPMR6001)
- 1/2 oz. [15g] Medium Pro CA+ Glue (GPMR6007)
- Pro 30-minute epoxy (GPMR6047)
- Denatured alcohol (for epoxy clean up)
- #1 Hobby knife (HCAR0105)
- #11 blades (5-pack, HCAR0211)
- #1 Phillips screwdriver (HCAR1022)
- #2 Phillips screwdriver (HCAR1024)
- Pliers
- Small metal file
- Masking tape
- 12mm (or appropriate size) prop wrench or crescent wrench
- Drill and drill bits: 1/16" [1.6mm], 5/64" [2mm], 3/32" [2.4mm], #19 (or 11/64") [4.4mm]

OPTIONAL SUPPLIES AND TOOLS

These items are not absolutely required, but are mentioned in the instructions and will help you assemble the Hobbistar .60 MKIII

- Top Flite® MonoKote® sealing iron (TOPR2100)
- Top Flite Hot Sock iron cover (TOPR2175)
- 4 oz. [113g] aerosol CA activator (GPMR634)
- CA applicator tips (HCAR3780)
- CA debonder (GPMR6039)
- Epoxy brushes (6, GPMR8060)
- Mixing sticks (50, GPMR8055)
- Mixing cups (GPMR8056)
- Builder's Triangle Set (HCAR0480)

- Pliers with wire cutter (HCAR0630)
- Masking tape (TOPR8018)
- K & S #801 Kevlar thread (for stab alignment, K+SR4575)
- Panel Line Pen (TOPQ2510)
- CG Machine™ (GPMR2400)
- Precision Magnetic Prop Balancer™ (TOPQ5700)
- Prop Reamer (GPMQ5005)

FIELD EQUIPMENT



When ready to fly, you'll need the equipment to fuel the plane and start the engine. Perhaps you've already made arrangements with the R/C club or your flight instructor to borrow theirs, but eventually you'll want to get your own. Refer to your hobby dealer for specific recommendations on what to purchase. Following is a list of the most important items...

- Model engine glow fuel (5%, 10% or 15% nitromethane content is suitable)
- Hand-crank or electric fuel pump system with fuel lines and fittings for transferring fuel from the container into the fuel tank in the model.
- Glow plug igniter for starting the engine
- Battery for glow plug igniter (if not already attached to igniter)
- Electric starter and 12v battery
- Field box for carrying starting equipment and tools

Kit Inspection

Before starting to build, take an inventory of all the parts to make sure the kit is complete and inspect the parts to make sure they are of acceptable quality. If any parts are missing or are not of acceptable quality, or if you need assistance with assembly, contact **Product Support**. When reporting defective or missing parts, use the part names exactly as they are written in the Kit Contents list on this page.

Product Support:

Telephone: (217) 398-8970

Fax: (217) 398-7721

E-mail: airsupport@hobbico.com

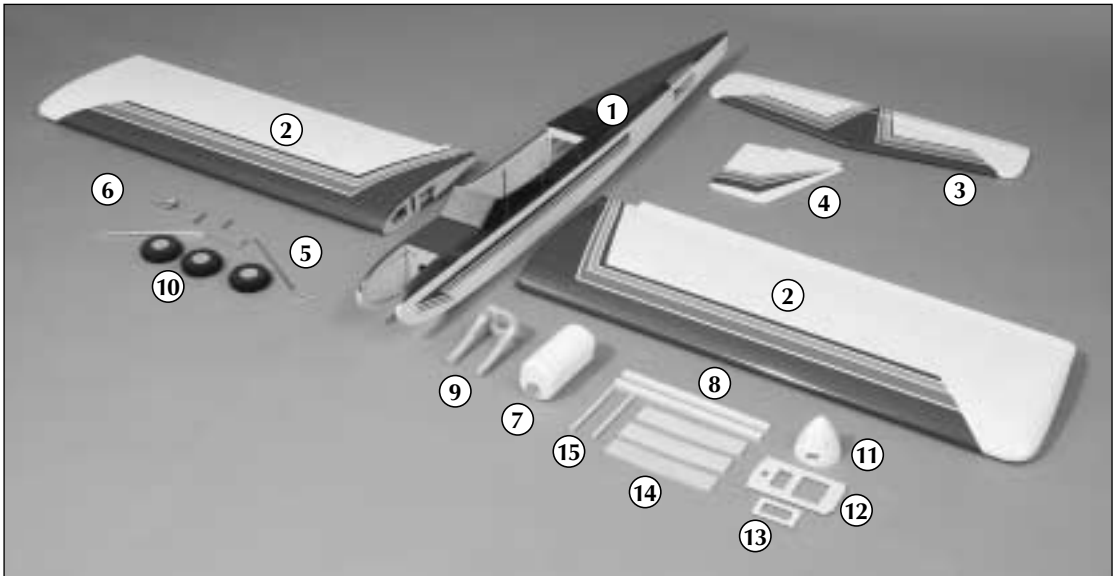

Parts Photographed

1. Fuselage	8. 1/4" x 1/2" x 10" [6 x 12 x 255mm] balsa stick (fuel tank, receiver, battery mounting) (2)	12. 1/8" [3.2mm] plywood fuselage servo tray
2. R&L wing halves w/ailerons	9. Cast aluminum engine mount	13. 1/8" [3.2mm] plywood wing servo tray
3. Stab w/elevator	10. 2-3/4" [70mm] foam wheels (3)	14. 1/8" [3.2mm] plywood wing joiners (3)
4. Fin w/rudder	11. 2-3/4" [70mm] white plastic spinner w/4 spinner screws	15. Hardwood wing dowels (2)
5. Main landing gear wires (2)		
6. Nose gear wire		
7. Fuel tank w/hardware		

Parts Not Photographed

(1) nylon nose steering arm	(4) 4 x 25mm Phillips-head screws (engine mounting)	(10) 3 x 5mm screw (for screw-lock connector, wheel collars)
(1) nylon nose gear mount	(6) 4 x 20mm Phillips-head screws (engine mount, nose gear bearing)	(1) 3 x 8mm screw (nose steering collar)
(2) 2mm x 9-7/8" [250mm] threaded one-end wire aileron pushrods	(10) 4mm lock washer	(2) 2mm washer (for pushrod connector)
(1) 2mm x 27" [685mm] threaded one-end wire throttle pushrod	(10) 4mm flat washer	(2) pushrod connector (screw-lock type)
(1) 2mm x 19-3/4" [500mm] wire nose wheel steering pushrod	(4) 4mm nut	(2) thumb nuts (for pushrod connectors)
(2) nylon aileron torque rod horns	(2) 2 x 16mm Phillips-head machine screws (rudder control horn mnt)	(2) metal engine mount straps
(2) nylon straps (main landing gear)	(2) 2 x 20mm Phillips-head machine screws (elevator control horn mnt)	(2) aileron torque rods (factory installed in wing)
(5) nylon clevises	(4) 3 x 12mm Phillips-head self-tapping screws (main LG straps)	(6) 4mm blind nuts (factory installed in firewall)
(5) nylon pushrod keepers	(4) 5mm wheel collars (main wheels)	(1) 13-1/2" [340mm] plastic pushrod tube (throttle)
(2) nylon control horns w/mnt plates	(5) 4mm wheel collars (nose wheel)	(1) 11-1/4" [285mm] plastic pushrod tube (for nose wheel)
(5) silicone retainers for clevises		(2) 36" [915mm] threaded one-end pushrods (elevator, rudder)
(15) precut CA hinges		

Ordering Replacement Parts

To order replacement parts for the Hobbico Hobbistar .60 MKIII ARF, use the order numbers in the **Replacement Parts List** that follows. Replacement parts are available only as listed. Not all parts are available separately (an aileron cannot be purchased separately, but is only available with the wing kit). Replacement parts are not available from Product Support, but can be purchased from hobby shops or mail order/Internet order firms. Hardware items (screws, nuts, bolts) are also available from these outlets. If you need assistance locating a dealer to purchase parts, visit www.hobbico.com and click on "Where to Buy." If this kit is missing parts, contact **Product Support**.

<u>Item</u>	<u>Description</u>	<u>How to Purchase</u>
Missing pieces		Contact Product Support
Instruction manual		Contact Product Support
Plans	Construction Plans	Not available
Hardware	Individual hardware items	Contact your hobby supplier
Parts listed below		Contact your hobby supplier
HCAA3120	Fuselage Set (Fuselage, servo tray, wing dowels(2))	
HCAA3121	Wing Set (Right & left wing panels w/aileron, hinges (8), plywood wing joiners (3), aileron servo tray)	
HCAA3122	Tail Set (Fin & rudder, stab & elevator, hinges (7))	
HCAA3123	Landing Gear Set (5mm main gear wires (2), 4mm nose gear wire, 5mm wheel collars & screws (4), 4mm wheel collars & screws (2))	

The Hobbistar .60 MKIII ARF is factory-covered with iron-on heat shrinkable model airplane covering. Should repairs ever be required, the covering can be patched with Top Flite MonoKote or other similar model airplane covering that has an iron-on adhesive on the back and shrinks with heat. Most coverings are packaged in six-foot rolls, but some hobby shops sell covering by the foot. If only a small piece is needed for a minor patch, perhaps a fellow modeler would give you some.

Metric Conversions

1/64" = .4mm	3/16" = 4.8mm	1" = 25.4mm	18" = 457.2mm
1/32" = .8mm	1/4" = 6.4mm	2" = 50.8mm	21" = 533.4mm
1/16" = 1.6mm	3/8" = 9.5mm	3" = 76.2mm	24" = 609.6mm
3/32" = 2.4mm	1/2" = 12.7mm	6" = 152.4mm	30" = 762mm
1/8" = 3.2mm	5/8" = 15.9mm	12" = 304.8mm	36" = 914.4mm
5/32" = 4mm	3/4" = 19mm	15" = 381mm	

To convert inches to millimeters, multiply inches by 25.4

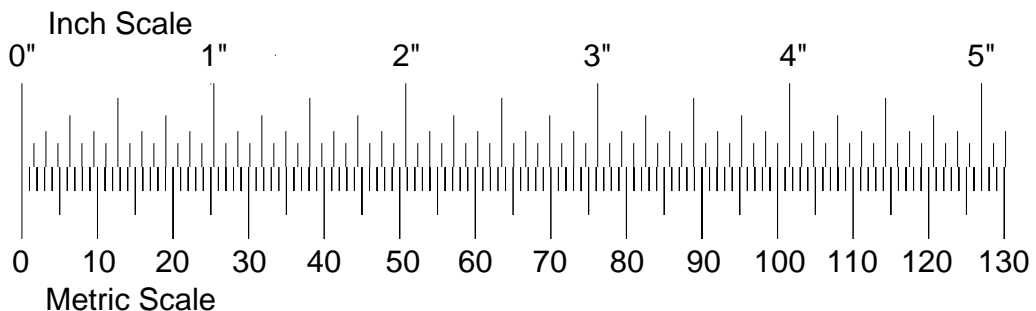

Tighten the Covering



Examine the covering on the model. Occasionally, the covering requires tightening to remove wrinkles that develop. If necessary, use a model airplane covering iron with a covering sock to tighten the covering and remove wrinkles. **Hint:** Poke three or four pin holes in the covering between the “ribs” in the tail surfaces, allowing air to escape to fully tighten the covering. **Note:** If you haven't yet purchased a covering iron (or borrowed one from a friend), this step may be done later.

Preparations

There are a few steps that require 30-minute epoxy that can be done first to speed assembly.

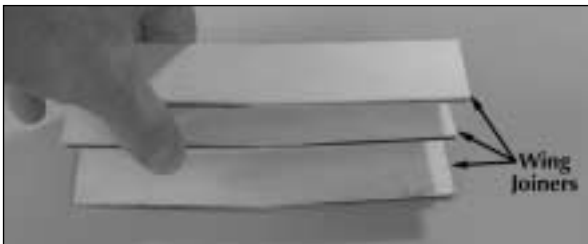

□ 1. Use 30-minute epoxy to glue together the three 1/8" [3.2mm] plywood **wing joiners**. Be certain to

apply epoxy to all mating surfaces. (In other words, apply epoxy to both sides of the joiner in the middle and to the inside of both the joiner on the top and the joiner on the bottom.) Hold the joiners together with clamps. Wipe away excess epoxy before it hardens.

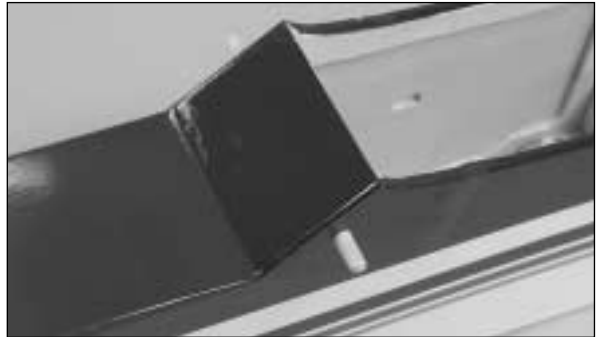

□ 2. Round the ends of both 1/4" [6.5mm] **wing dowels**. Cut the covering from the holes in the fuselage for the dowels and glue them into position with 30-minute epoxy. Lightly coat the dowels with epoxy. (Only the **front** dowel is shown in the photo, but there is a dowel at the aft end of the cutout in the fuselage for the wing.)



□ 3. Use a hobby knife to bevel the inside edges of the holes in the main landing gear rail where indicated by the arrows to accommodate the bend in the landing gear wire. Seal the exposed wood in the landing gear rail with a light coat of epoxy.



□ 4. Seal the edges of the covering around the engine compartment with a thin coat of 30-minute epoxy. Also use 30-minute epoxy to lightly coat the inside of the fuselage all the way around the opening for the wing (as indicated by the shaded area). This will fuelproof the bare wood in case engine exhaust residue seeps in.

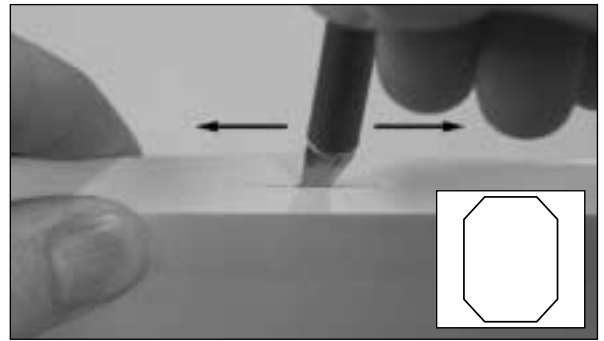

□ □ 2. Test fit the aileron to the wing with four **CA hinges** but **do not glue them in yet**. If it is difficult to join the aileron to the wing because the hinge slots are too tight, remove the hinges. Widen the hinge slots by inserting a #11 blade and moving it back and forth a few times.

Assemble the Wing

JOIN THE AILERONS

Start with the right wing so yours matches the photos the first time through.

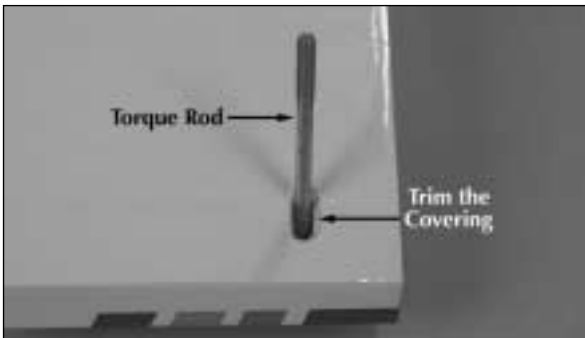

□ □ 1. Use a hobby knife with a #11 blade to neatly trim the covering from the bottom of the right wing around the aileron **torque rod** to allow full, unrestricted movement of the rod.

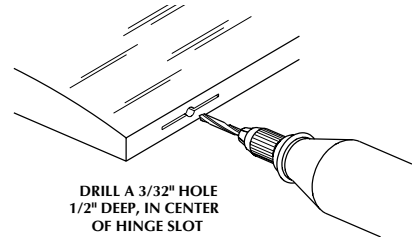

DRILL A 3/32" HOLE
1/2" DEEP, IN CENTER
OF HINGE SLOT

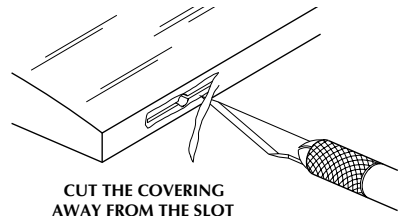

CUT THE COVERING
AWAY FROM THE SLOT



□ □ 3. Remove the aileron from the wing. Drill a 3/32" [2.4mm] hole 1/2" [13mm] deep in the center of the hinge slots to allow the thin CA used for gluing in the hinges to fully "wick" all the way in. Cut a small strip of covering from all the hinge slots in the wing and aileron. For the best result, use a high-speed tool such as a Dremel to drill the holes.

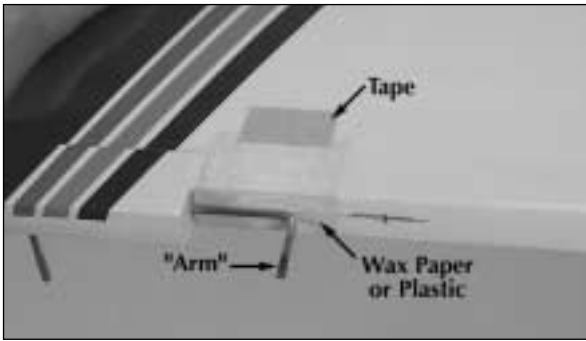

□ □ 4. Tape a small piece of wax paper or a piece of plastic from a sandwich bag to the wing under the aileron torque rod. Coat the “arm” portion of the torque rod and the hole and the slot in the aileron for the torque rod with 30-minute epoxy. Immediately proceed to the next step.



□ □ 5. Join the aileron to the torque rod and wing with the hinges. If the hinges don't remain centered, stick a pin through the hinge to hold it in position. Be certain there is a **small** gap between the aileron and the wing—just enough to slip a piece of paper through or to see light through. Remove any pins that were used to center the hinges.

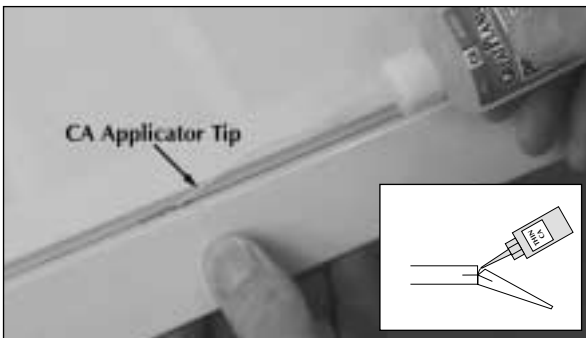

□ □ 6. Apply six drops of thin CA to both sides of all the hinges. Allow a few seconds between drops so the CA **fully** soaks into the hinge rather than being

drawn into the hinge gap thus gluing the aileron to the wing. Note the CA applicator tip (HCAR3780) on the CA bottle to control and pinpoint the CA that comes out.

□ □ 7. Stack a few paper towels over each other and cut them into approximately 2" [50mm] squares. Moisten one of the squares with denatured alcohol and use it to wipe away excess epoxy that came out of the aileron.

□ 8. Return to step 1 and join the left aileron to the left wing panel the same way.

JOIN THE WING

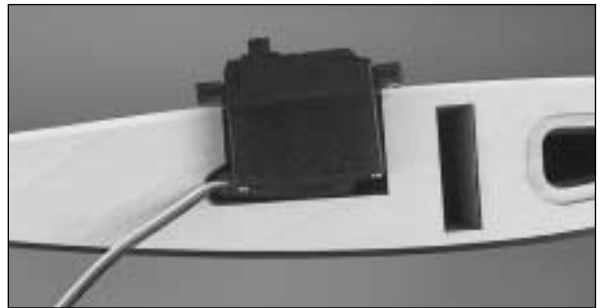

□ 1. Test fit the aileron servo in both wing halves to make sure the servo fits. If necessary, enlarge the cut outs in the wing to accommodate the servo.

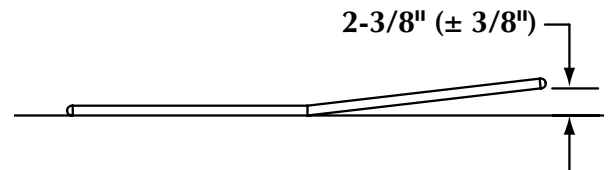
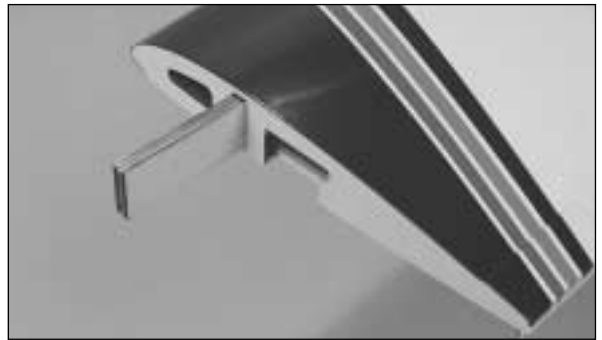

□ 2. Test fit the wing joiner you glued together earlier into both wing halves, then test fit the wing halves with the joiner. There should be no gap in the wing.

Assemble the Fuselage

MOUNT THE STABILIZER AND FIN

Make certain the joiner is installed upright (so the wing tips are higher than the middle of the wing). Make adjustments where necessary for a good fit (sanding the top and bottom of the joiner to even the edges or remove excess epoxy may be required). **Note:** The wing dihedral (or upward angle between the joining wing halves) is factory set and is determined by the shape of the wing joiners. However, some modelers prefer to check the wing dihedral anyway. To do so, lay one wing half on a flat surface. As shown in the sketch, the end of the other wing (not including the wing tip) should be 2-3/8" above the surface. A variance of approximately 3/8" is acceptable.

❑ 3. Separate the wing halves and remove the joiner. **Thoroughly** coat the end of one wing half and the inside of the wing where the joiner fits with 30-minute epoxy. Also coat one half of the joiner all the way around. Install the coated end of the joiner into the wing half. Proceed immediately to the next step.

❑ 4. Coat the inside and the end of the other wing with 30-minute epoxy. Also coat the end of the joiner that is sticking out of the other wing half. Fit the wings together.

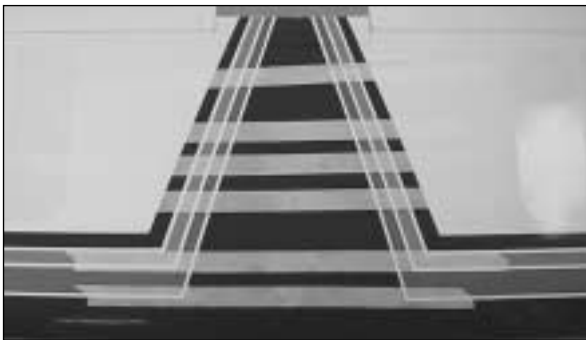

❑ 5. **Tightly** hold both wing halves together with **several** strips of masking tape on **both** the **top** and **bottom** of the wing. **Be certain** the leading and trailing edges of the wing align. As you apply the tape, wipe away excess epoxy that comes out. Do not disturb the wing until the epoxy has fully hardened.

❑ 1. The same as was done for the wing and ailerons, prepare the stabilizer and elevator and fin and rudder for hinging (by test fitting the hinges, cutting a strip of covering from the slots and drilling the holes). Do not glue in the hinges until instructed to do so.

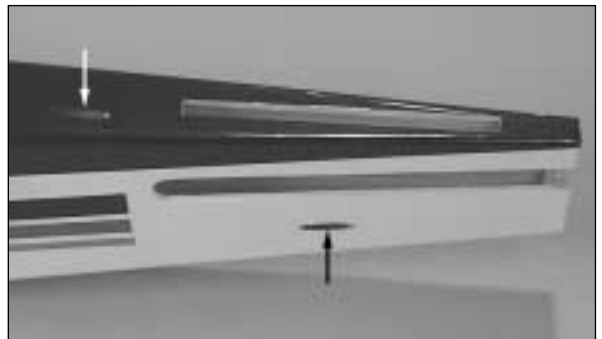

❑ 2. Cut the covering from the slots in the fuselage for the stabilizer and fin. Also cut the covering from the pushrod tubes on the top and left side of the fuse (where indicated by the arrows in the photo).

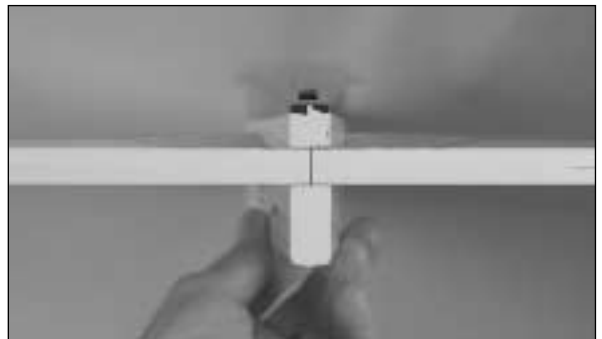

❑ 3. Taking accurate measurements, mark the center of the stab on the trailing edge. Position the stab in the fuselage. Center the mark on the trailing edge with the end of the fuse.

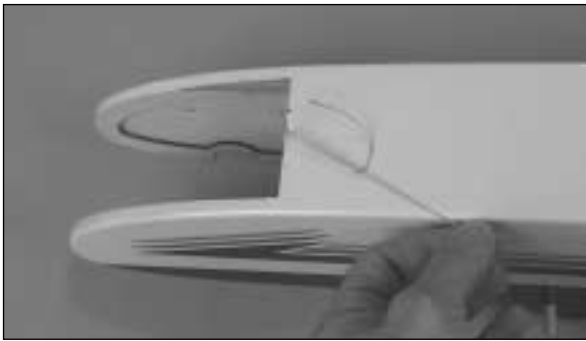

❑ 4. Turn the fuse upside-down. Stick a T-pin through the bottom of the firewall centered side-to-side. Tie a small loop in one end of a 50" [1300mm] piece of non-elastic string such as monofilament or Kevlar line (K+SR4575) and slip it over the T-pin.

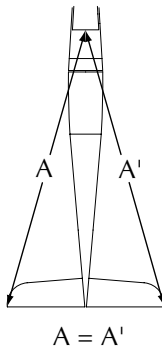

❑ 5. Fold a piece of masking tape over the string near the other end and draw an arrow on it. Slide the tape along the string and align the arrow with one end of the stab as shown in the photo. Swing the string over to the same position on the other end of the stab. While keeping the stab centered from side-to-side, adjust the stab and slide the tape along the string until the arrow aligns with both ends of the stab and the stab is centered as shown by $A=A'$ in the sketch. Be certain the centerline on the trailing edge remains centered in the fuselage.

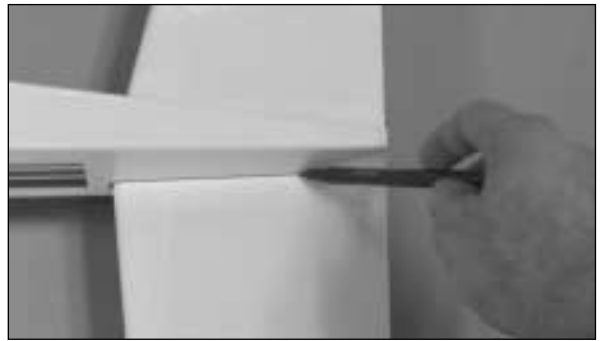

❑ 6. Use a fine-point felt-tip pen such as a Top Flite® Panel Line Pen (TOPQ2510) to mark the outline of the fuselage on the top and bottom of the stab.

❑ 7. Remove the stab from the fuse. Use a sharp #11 hobby knife or follow the **Expert Tip** below to cut the covering from the stab along the lines. Use care to cut **only** into the covering and **not** into the wood. Cutting into the balsa will weaken the structure.

Expert Tip:
How to cut covering from balsa.



To avoid cutting into the balsa, use a soldering iron instead of a hobby knife to cut the covering. The tip of the soldering iron doesn't have to be sharp, but a fine tip does work best. Allow the iron to heat fully. Use a straightedge to guide the soldering iron at a rate that will just melt through the covering and not burn into the wood. The hotter the soldering iron, the faster it must travel to melt a fine cut.

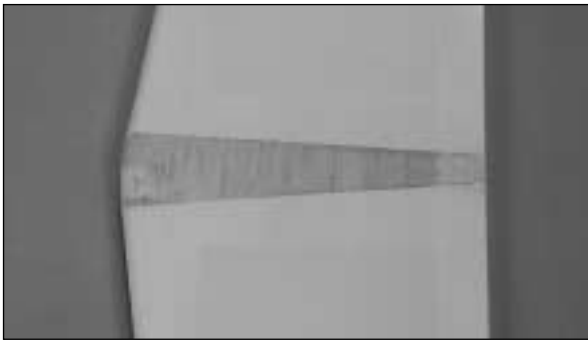

❑ 8. Peel the covering from the stab. Remove any ink left on the stab with one of the small paper towel squares you cut earlier, moistened with denatured alcohol. Also remove any ink around the slot for the stab that may be on the fuselage.



❑ 9. Mount the wing to the fuselage with a couple of #64 rubber bands. Slide the stab back into the fuselage. Stand eight to ten feet behind the model and observe the alignment between the stab and wing. If the stab does not align with the wing, place a small weight on the “high side” of the stab to bring it into alignment. If weight is not enough to tilt the stab to one side, remove the stab from the fuselage. **Carefully** sand the slot in the fuselage as necessary to get the stab to align with the wing.



❑ 10. **Thoroughly** coat the slot in the fuselage for the stab and the stab where it contacts the fuselage with

30-minute epoxy. Working quickly, slide the stab into position. Wipe off any epoxy deposited on the stab. Use the pin and string to be certain the stab is in alignment. Use a small clamp to hold the stab in position until the epoxy hardens.

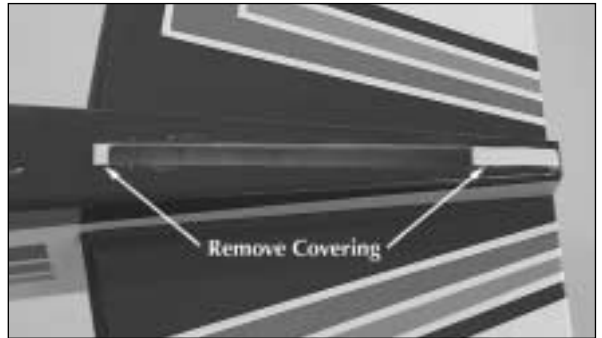

❑ 11. The same as was done to the stab, trim the covering from both sides of the fin where it will be glued into the fuselage. Also trim the covering from the top of the fuselage just in front of and behind the slot in the fuse where the fin will go.

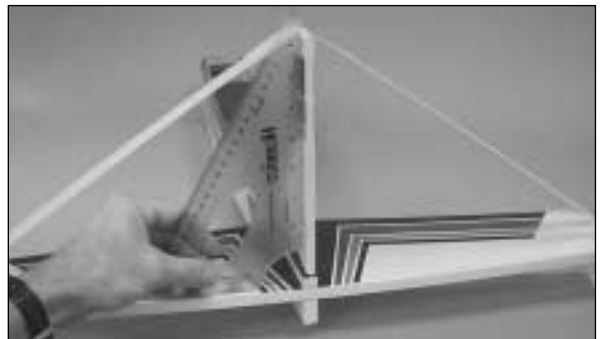

❑ 12. Use 30-minute epoxy to glue the fin to the fuse. Hold the fin in position with masking tape. Before the epoxy hardens, use a Hobbico® Builder's Triangle (HCAR0480) to see if the fin is perpendicular to the stab. If necessary, adjust the tension on the tape to pull the fin to one side or the other until it is vertical.

❑ 13. Permanently join the elevator to the stab and the rudder to the fin with the hinges and thin CA.

MOUNT THE LANDING GEAR

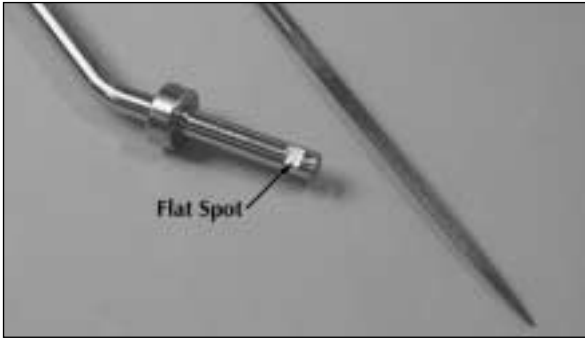

❑ 1. Mount the main wheels to the main landing gear wires using a 5mm wheel collar and a 3 x 5mm Phillips-head screw on both sides of each wheel. Before mounting the outer wheel collar (that holds the wheel on), file a **flat spot** on the wire for the set screw. This will ensure that the wheel collar remains secure so the wheels won't fall off! **Note:** Before installing the set screws in the wheel collars, add a **small** drop of threadlocker to the screw.

❑ 2. Add a small drop of oil to both sides of the wheels.

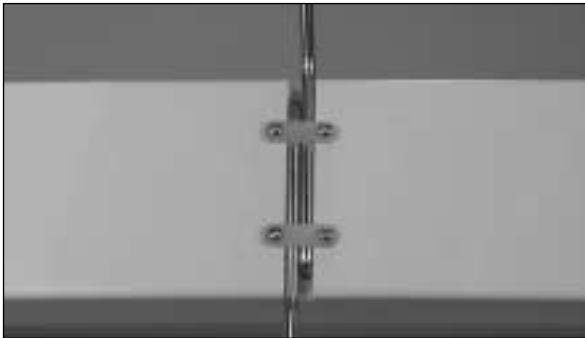

❑ 3. Install the main landing gear wires into the main landing gear rail in the fuselage. Using the holes in one of the nylon **landing gear straps** as a guide, drill 3/32" holes through the landing gear rail for the mounting screws. Run a 3 x 12mm screw in and out of each hole a few times, then add a few drops of thin CA to the holes. Allow the CA to fully harden, then mount the straps to the fuselage with four 3 x 12mm screws.

❑ 4. Mount the **engine mount** to the firewall with four 4 x 20mm screws and 4mm washers and lock washers. Be certain to **securely** tighten the screws using a #2 Phillips screwdriver.

❑ 5. Mount the nose wheel to the nose gear wire with a 4mm wheel collar and a 3 x 5mm screw on both sides of the wheel. The same as the main wheels, be certain to file a flat spot on the wire for the outer wheel collar and add a drop of oil to both sides of the wheel to help it spin freely.



Refer to this photo for the following two steps.

❑ 6. Insert two 4 x 20mm screws and 4mm lock washers into the holes in the nylon **nose gear mount**. Insert two 4mm flat washers onto each screw on the **back** of the nose gear mount. Mount the nose gear mount to the firewall.

❑ 7. Insert the nose gear wire into the nose gear mount and the bottom hole in the engine mount. If the nose gear wire will not go in, or if it will not turn easily once inserted, remove the nose gear wire. Drill-out the nose gear mount and the bottom hole in the engine mount with a #19 (or 11/64") [4.4mm] drill. This will align the holes. Install the nose gear wire.

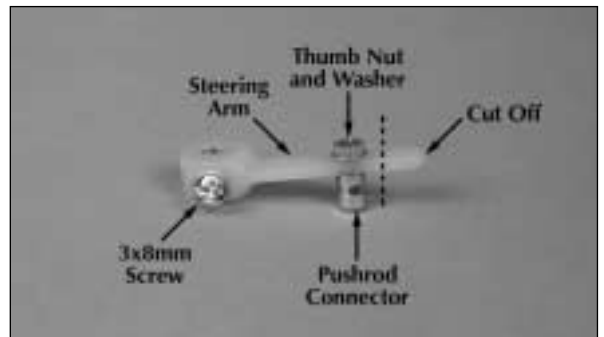

❑ 8. Enlarge the inner hole in the nylon **steering arm** with a 5/64" [2mm] (or 3/32" [2.4mm]) drill and cut the outer "two holes" off. Insert a 4mm wheel collar into the steering arm, then screw in a 3 x 8mm Phillips-head screw. Insert a **threaded pushrod**

connector into the hole, then slip on a washer. Add a small drop of threadlocker to the threads, then screw on a thumb nut. Tighten the nut, but not so much as to stop the connector from rotating in the hole. **IMPORTANT:** As the thumb nut cannot be fully tightened, threadlocker **must** be used on the threads to keep it from coming off.



Refer to this photo for the following three steps.

❑ 9. Temporarily mount the nose gear using the steering arm and two 4mm wheel collars with 3 x 5mm screws as shown.

❑ 10. Cut the 11-1/4" [285mm] plastic pushrod tube to a length of 6-1/2" [165mm]. Roughen the outside of the tube so glue will adhere and insert it through the hole in the firewall, through the large hole in the former behind the firewall and through the hole in the former behind that. Make sure the front of the pushrod tube is even with the front of the firewall. Glue the pushrod tube into the firewall and the third former.

❑ 11. Slide the 2mm x 19-3/4" [500mm] non-threaded wire pushrod through the connector on the steering arm and into the pushrod tube in the firewall. If necessary, bend the front of the pushrod to align with the connector then cut the pushrod to the correct length. Temporarily fasten the pushrod to the connector with a 3 x 5mm screw.



❑ 12. Mount the wing to the fuselage with two #64 rubber bands. Place the model on its landing gear. Set the engine (or anything heavy enough to hold the front end down) on the engine mount. View the model from the side. Raise or lower the nose gear until the model is level. Using a small drop of thread locking compound on the screws in the wheel collars, tighten the screws to securely lock the nose gear into position.

MOUNT THE ENGINE

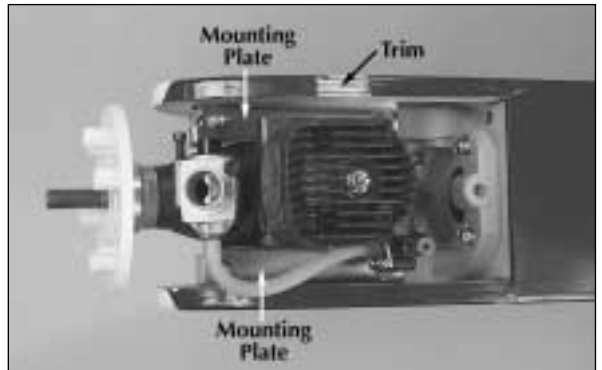

Refer to this photo to mount the engine.

❑ 1. Place the engine on the engine mount, then place the metal **mounting plates** on both sides of the engine. Install four 4 x 25mm screws with 4mm lock washers and 4mm flat washers into the holes in the plate and the engine mount. One at a time, install a 4mm nut into the recesses in the bottom of the engine mount and thread them onto the screws, but do not fully tighten the screws.

❑ 2. If necessary, enlarge the hole in the back plate of the spinner, then place it on the engine.

❑ 3. Center the engine on the mount, then use a #2 Phillips screwdriver to securely tighten the engine mounting screws.

❑ 4. Test fit the muffler to the engine. If necessary, use a Dremel tool with a drum sander or a hobby knife to trim the fuselage to accommodate the muffler. (If using a Dremel, stuff the engine exhaust and the opening in the carburetor with a piece of a paper towel to keep dust from entering.) Coat the exposed wood with epoxy or medium CA.

INSTALL THE FUEL TANK

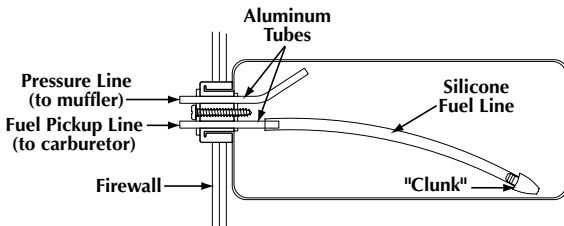
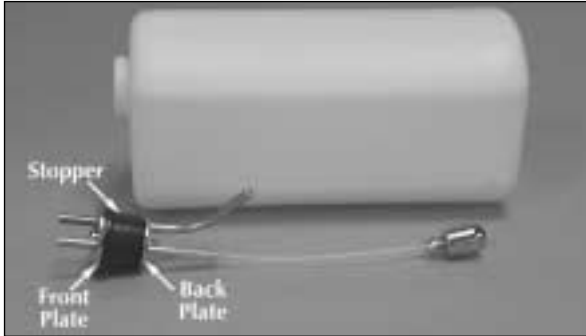

Refer to the photo and the sketch while installing the fuel tank.

❑ 1. Pull the stopper out of the fuel tank and shake out the contents. Note that there are three holes in the back of the stopper, but two holes in the front. The fuel system on this model requires only two lines (a fuel **pickup** line and the **pressure** line), so the third hole in the stopper will not be used.

❑ 2. Insert the **long** aluminum tube into the metal **front plate** and push it through the hole in the **right** side of the **stopper** until approximately 1/2" [13mm] of the tube protrudes from the front. Insert the short aluminum tube through the other hole.

❑ 3. Tighten the screw just until the metal **back plate** contacts the back of the stopper. Bend the long aluminum tube upward as shown in the photo so it will be near the top of the tank when the assembly is installed in the tank.

❑ 4. Fit the fuel line to the short aluminum tube. Cut the fuel line to the correct length so that when the fuel line weight ("clunk") is installed, it will be near, but not contacting the back of the tank. Otherwise, the line may become stuck above the fuel level discontinuing fuel flow.

❑ 5. Note that the tube in the right side of the tank is the pressure line that will be connected to the muffler and the tube in the left side of the tank is the fuel tube which will be connected to the carburetor. Install the stopper and fuel line assembly into the tank. Make certain the clunk is not contacting the back of the tank, then tighten the screw to expand the stopper, thus sealing the tank – approximately five or six full turns should be adequate.



❑ 6. Install the fuel tank into the fuselage with the neck of the tank through the hole in the firewall. Cut 3-1/8" [80mm] from one of the 1/4" x 1/2" x 10" [6 x 12 x 255mm] balsa sticks. Trim the 3-1/8" [80mm] piece as necessary to fit between the back of the tank and the former to secure the fuel tank.

MOUNT THE AILERON SERVO

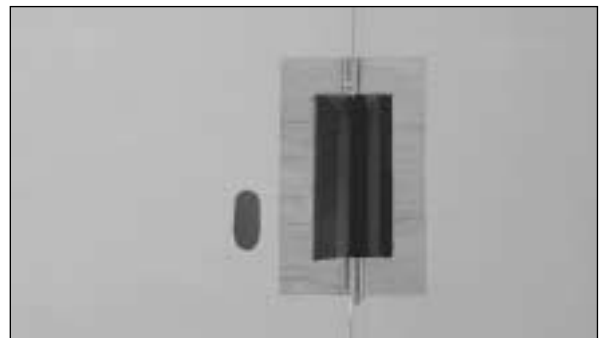

❑ 1. Cut a small hole in the bottom of the wing for the servo wire. Cut the covering from the wing for the 1/8" [3.2mm] plywood **aileron servo tray**.

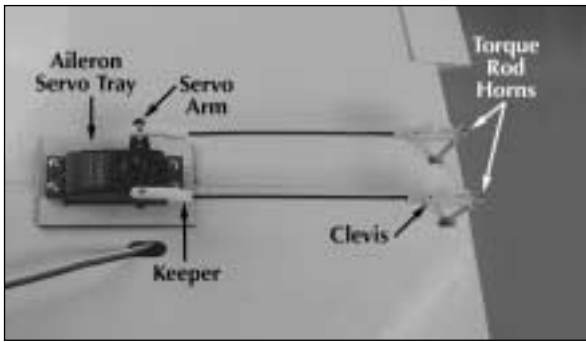

Refer to this photo while mounting the aileron servo.

- ❑ 2. Use epoxy to glue the aileron servo tray to the wing.
- ❑ 3. Drill 1/16" holes through the servo tray for mounting the servo. Run the servo screws in and out of the holes a few times to make some threads in the wood. Add a few drops of thin CA to the holes and allow to fully harden. Mount the servo in the wing using the screws that came with the servo.
- ❑ 4. Make a two-arm servo arm from a four-arm servo arm by cutting two of the arms off. Mount the servo arm to the servo.
- ❑ 5. Screw a nylon clevis twenty-five full turns onto a 2mm x 9-7/8" [250mm] pushrod. Make another pushrod the same way. Screw the nylon **torque rod horns** twelve full turns onto the aileron torque rods.

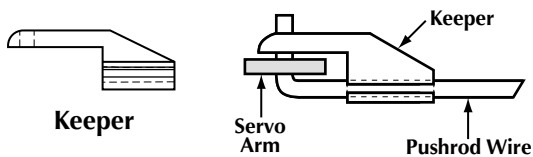

- ❑ 6. Connect one of the clevises on the pushrod to one of the torque rod horns. Make a 90-degree bend in the pushrod so that when connected to the servo arm, the aileron will be centered. Fit the pushrod in the second from the outer hole in the servo arm, then secure it with a nylon pushrod **keeper**. Cut the pushrod 1/16" [2mm] from the keeper as shown in the sketch. **Note:** It may be necessary to enlarge the holes in the servo arm to fit the pushrod. If so, use a hobby knife with a #11 blade to carefully enlarge the holes from both sides of the arm.

- ❑ 7. Connect the other pushrod to the servo arm and the torque rod the same way.
- ❑ 8. Center the servo arm. Adjust the length of the pushrods by turning the clevises in or out until both ailerons are centered.

HOOK UP THE CONTROLS

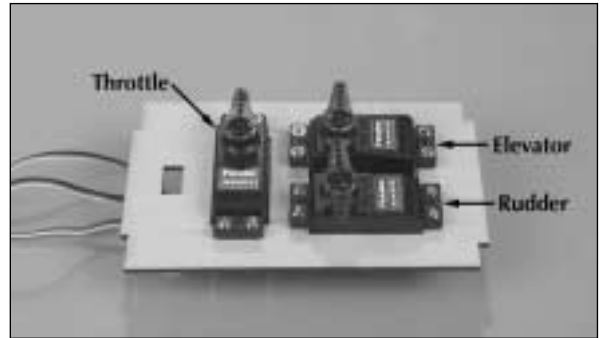

Refer to this photo for the following three steps.

- ❑ 1. Make two one-arm servo arms from the arms that came with the servos. Also make one two-arm servo arm.
- ❑ 2. Install the arms on the servos, then test fit the servos in the 1/8" [3.2mm] plywood **fuselage servo tray** as shown. If necessary, enlarge the openings in the tray to accommodate your servos.
- ❑ 3. Drill 1/16" holes through the servo tray for mounting the servos. Run the servo screws in and out of the holes a few times to make some threads in the wood. Add a few drops of thin CA to the holes to harden the threads. After the CA has fully hardened, mount the servos in the tray.
- ❑ 4. Refer to the photo at step 6. Use epoxy to securely glue the servo tray in the fuselage. Cut the **elevator** and **rudder pushrod tubes** so they "end" approximately 1/8" [3mm] ahead of the former on the aft end of the servo tray.

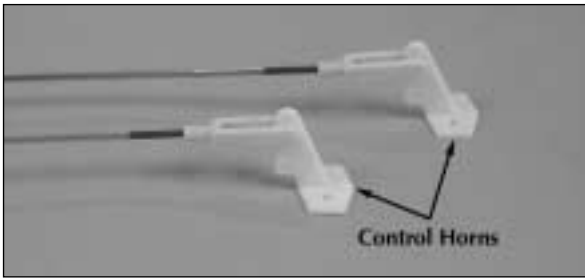

- ❑ 5. Screw a clevis twenty-five full turns onto a 2-56 x 36" [915mm] pushrod. Connect the clevis to the second-from-the-outer hole of a control horn. Make another pushrod assembly the same way.

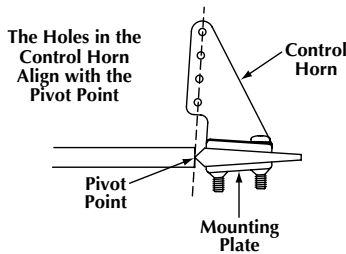

- ❑ 6. Slide the pushrods into the pushrod tubes in the fuselage. Position the control horn on the rudder as shown in the photo and sketch. Use the control horn as a guide to drill two 5/64" [2mm] (or 3/32" [2.4mm]) holes through the rudder for the mounting screws. Mount the control horn to the rudder with two 2 x 16mm Phillips-head screws and the plastic mounting plate.

- ❑ 7. Mount the elevator control horn to the elevator with two 2 x 20mm Phillips-head screws.

- ❑ 8. **Carefully** enlarge the holes in the elevator and rudder servo arms with a hobby knife and a #11 blade or a 5/64" [2mm] drill.

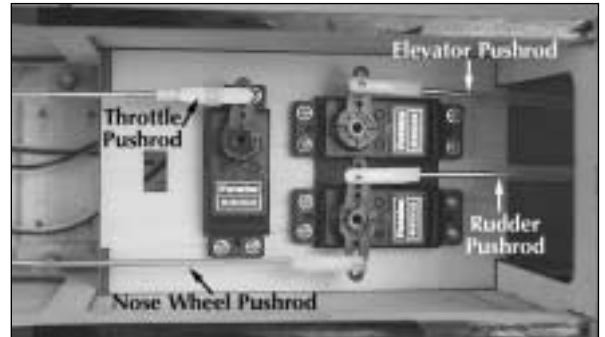

Refer to this photo while connecting the pushrods to the servos.

- ❑ 9. Make a 90-degree bend in the elevator pushrod so the elevator will be centered when the pushrod is connected to the servo arm. This is most easily done by disconnecting the pushrod from the elevator, rotating the pushrod 90-degrees, then making the bend to the side. The clevis on the back of the pushrod will now have to be turned 90-degrees the other way. Take the servo arm off the elevator servos and fit the pushrod in the third hole out. Install the pushrod keeper, then cut the wire so 1/16" [2mm] protrudes. Reinstall the servo arm and clevis.

- ❑ 10. Connect the rudder and nose wheel pushrod the same way. A few bends will have to be made in the nose wheel pushrod to align it with the servo arm.



- ❑ 11. Use the remaining 13-1/2" [340mm] plastic pushrod tube and the 2mm x 27" [685mm] threaded

one-end wire pushrod to hook up the throttle. A nylon clevis is used on the aft end of the pushrod to connect it to the servo arm and a threaded pushrod connector is used on the front of the pushrod to connect it to the carburetor arm. Bend the pushrod as necessary to align it with the threaded pushrod connector and be certain to use threadlocker on the thumb nut. Adjust the pushrod so the carburetor is half-open when the throttle servo arm is centered.

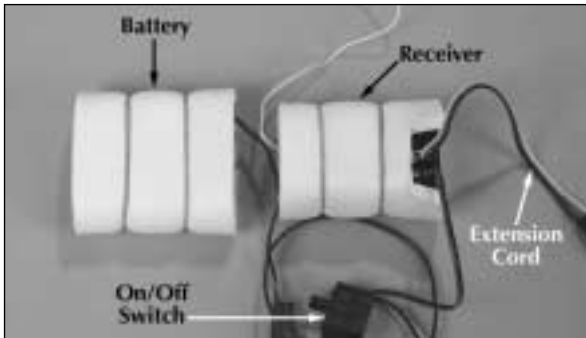

□ 12. Wrap the receiver and battery pack in 1/4" [6mm] (or 1/2" [13mm]) R/C foam rubber. Hold the foam rubber in place with tape or rubber bands. Connect a servo extension cord to the aileron plug in the receiver (numbered "1" on most receivers) and connect the on/off switch to the receiver as well. Connect the battery to the switch.

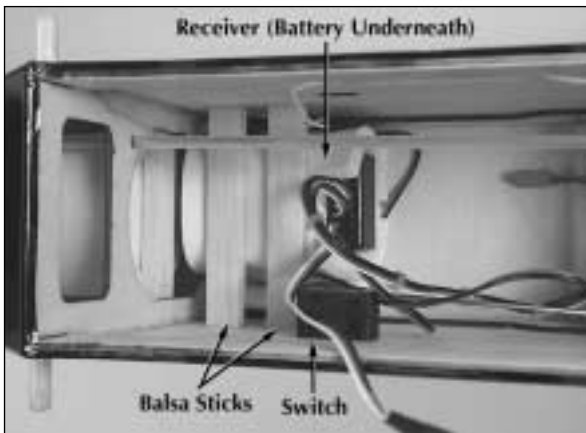

□ 13. Connect the throttle, elevator and rudder servos to the receiver. Place the receiver and battery in the fuselage, then glue pieces of the 1/4" x 1/2" [6 x 13mm] balsa stick to the fuselage sides across the receiver and battery to **securely** hold them down. Make certain nothing interferes with the movement of the throttle or nose wheel steering pushrods. Cut the covering from

the square hole in the **left** side of the fuselage for the on/off switch. Drill two 3/32" [2.4mm] holes for the switch mounting screws and mount the switch.

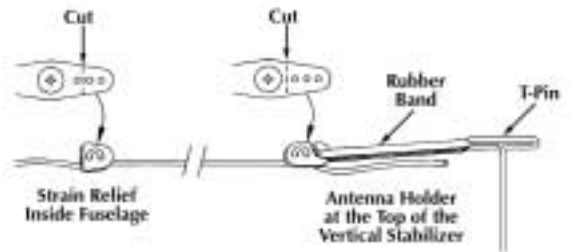
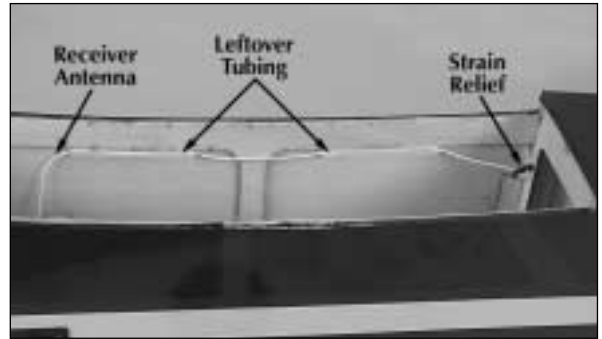

□ 14. Glue leftover pieces of pushrod tubing inside the fuselage to guide the receiver antenna away from the servos and pushrods. Route the antenna through the tubes. Make a "strain relief" from a cut off servo arm and route the antenna through two of the holes. Drill a 1/16" [1.6mm] hole through the fuselage side for routing the antenna. Route the antenna through the hole in the fuselage.



□ 15. Make a "hook" for the antenna from another cut off servo arm and connect it to the antenna. Use needle nose pliers to make a loop on the end of a pin or a small piece of wire. Stick the wire into the top of the fin and connect it to a small rubber band which is, in turn, connected to the hook on the antenna.

MOUNT THE MUFFLER, PROP AND FUEL LINES

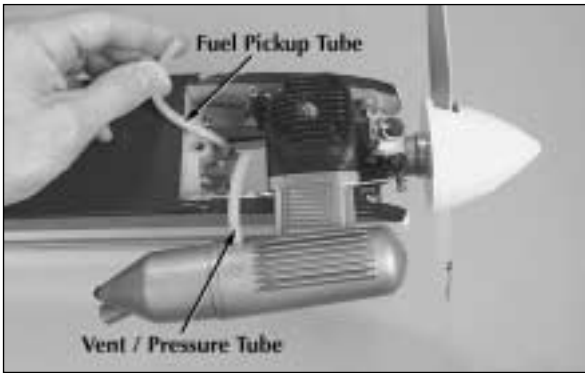

Refer to this photo while mounting the muffler and installing the fuel lines.

- ❑ 1. Mount the muffler to the engine. Note that on some engines the exhaust outlet may be rotated so the engine exhaust can be directed away from the model. Rotate the outlet if necessary.
- ❑ 2. Using medium silicone fuel tubing, connect the vent/pressure tube coming from the fuel tank to the muffler and connect the pickup tube coming from the fuel tank to the carburetor. If using the O.S.® MAX .65 LA or another engine with a remote needle valve, make the fuel line a little extra long so it will be easier to handle the line for filling the fuel tank (as the tank is filled through this line).



- ❑ 3. Fit the back-plate of the spinner and a suitable propeller to the engine. If the hole in the back-plate and prop are too small, use a prop reamer or the correct-size drill to enlarge the holes (a 5/16" drill is suitable for engines that have a 5/16"-24 crank shaft such as the O.S. MAX .65 LA). A prop reamer is best as it self-centers as it enlarges the hole.

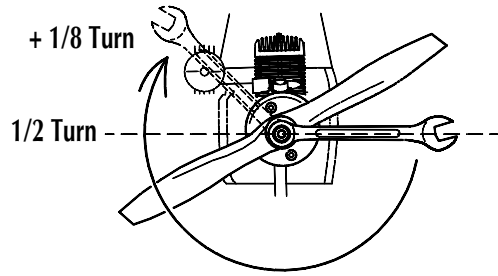

- ❑ 4. Install the prop washer and prop nut. Tighten the prop nut "finger-tight," then use the correct-size wrench (12mm for most engines) to tighten the prop nut by turning it 1/2 turn, plus another 1/8 turn. This should be adequate tightness.
- ❑ 5. Fit the spinner cone over the propeller onto the spinner back plate, then secure with the four screws that came with the spinner.

Prepare the Model for Flying

BALANCE THE MODEL (C.G.)

More than any other factor, the **C.G.** (center of gravity, also referred to as the balance point) can have the **greatest** effect on how a model flies and may determine whether or not the first flight will be successful. If the plane is nose heavy it could be difficult to takeoff and land and lose some of its self-recovery capabilities. If the plane is tail heavy the controls may be too sensitive, making the model overreact to control inputs. If you value this model and wish to enjoy it for many flights, **DO NOT OVERLOOK THIS IMPORTANT PROCEDURE.** A model that is not properly balanced will be unstable and possibly unflyable.

At this time the model must be in “ready-to-fly” condition with all components installed including the complete radio system, landing gear, engine, prop and spinner. The model is to be balanced with the fuel tank empty.

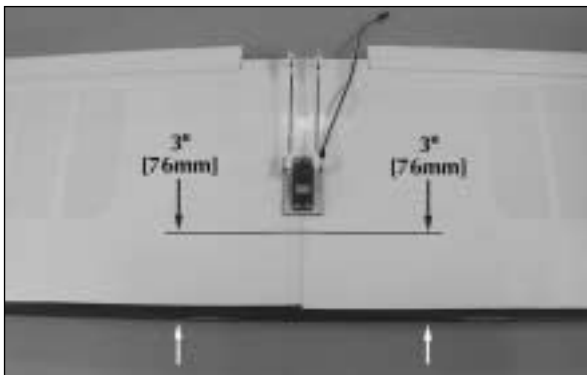

❑ 1. If using a Great Planes® C.G. Machine™ to balance the model, set the rulers to 3" [76mm]. If you do not have a Great Planes C.G. Machine, use a felt-tip pen or 1/16" to 1/8" [1.5 to 3mm] tape to accurately mark the C.G. 3" [76mm] from the leading edge on the bottom of the wing.

This is where the model should balance for the first flights. Later, you may wish to experiment by shifting the C.G. up to 1/2" [13mm] forward or 1/2" [13mm] back to change the flying characteristics. Moving the C.G. forward will increase stability, but will decrease the model's aerobatic capabilities by decreasing maneuverability. Moving the C.G. aft will have the opposite effect. In any case, as long as the model is balanced **within the recommended range** it will not display any bad tendencies. Do not at any time balance the model outside the recommended range.

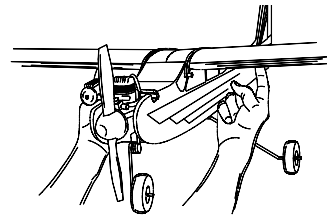

❑ 2. Mount the wing to the fuselage with at least four #64 rubber bands. If using a C.G. Machine, place the model on the machine. If not using a C.G. Machine, use the tip of your middle fingers on both hands to lift the model by the wing on both sides of the fuselage at the balance point you marked on the bottom of the wing.



❑ 3. If the fuselage is level when lifting the model the C.G. is correct. If the nose drops the model is nose-heavy and will require weight on the tail to balance.

If however, the tail drops, the model is tail heavy and the model will require weight on the nose to balance. Determine how much weight will be required by **temporarily** placing varying amounts of Great Planes "stick-on" lead weight (GPMQ4485) over the nose or tail until the correct amount is determined. Our prototypes required about 2-1/2 oz. [70g] of lead on the tail to balance so it is likely that your model will require some amount of tail weight as well. Don't be alarmed if your model requires more or less tail weight than ours did. There are several factors that can determine the amount of weight required such as the exact position and weight of the engine, density of wood the model was constructed from, etc.

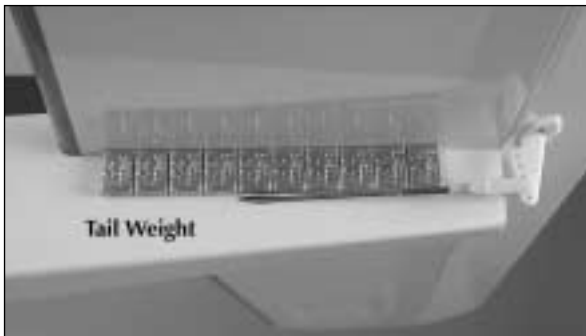
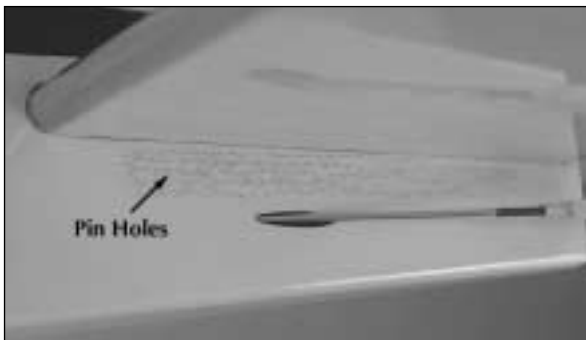

❑ 4. Attach weight to the model where required. If nose weight is required it should be adhered to the firewall or

the inside of one of the fuselage sides in front of the firewall. Due to the likelihood of fuel coming into contact with the double-sided foam tape that holds the lead in place, the best way to secure nose weight is to scrape off the foam tape and permanently glue the lead into place with epoxy. If tail weight is required, do not simply adhere the lead to the covering. Instead, use a pin to poke several holes in the covering over the left side of the fuselage (opposite the engine exhaust) under the stabilizer. Add several drops of thin CA to the area to thoroughly bond the covering to the wood. Now the lead may be stuck to the fuselage. Be certain any weight stuck to the tail does not interfere with the pushrods.

Note: An optional way to add nose weight, if required, is to use a "spinner weight" (GPMQ4645 for 1 oz. [29g] weight, or GPMQ4646 for 2 oz. [57g] weight). Spinner weights are used in place of the prop washer.

❑ 5. **IMPORTANT:** If you found it necessary to add any weight, recheck the C.G. after the weight has been added.

CENTER THE SERVOS



❑ 1. Set the wing upside-down on a small cardboard box or a stand and place it next to the fuselage. Connect the aileron servo wire from the wing to the servo extension coming from the receiver.

❑ 2. Take the servo arms off all the servos.

❑ 3. Center all the trim levers on the transmitter. Turn on the transmitter, then the receiver. (The idea is to never have the receiver on by itself. When turning off the system, turn off the receiver first, then the transmitter.) This will "center" the servos. Reinstall the servo arms on all the servos followed by the screws that hold on the arms.

CHECK THE CONTROL DIRECTIONS

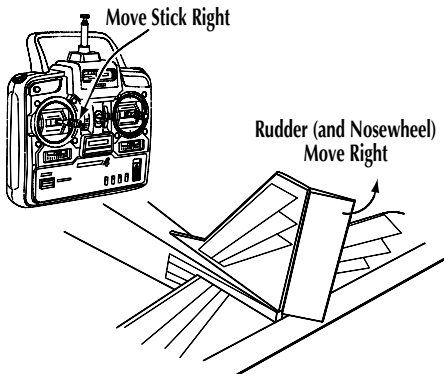
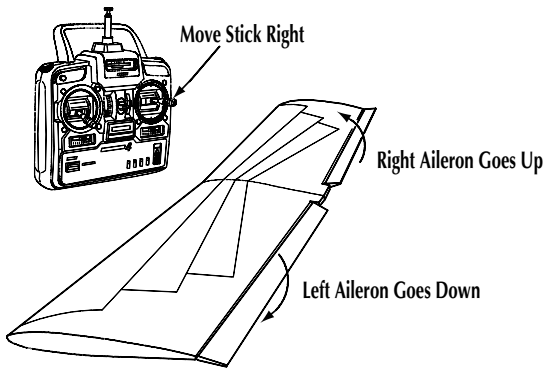
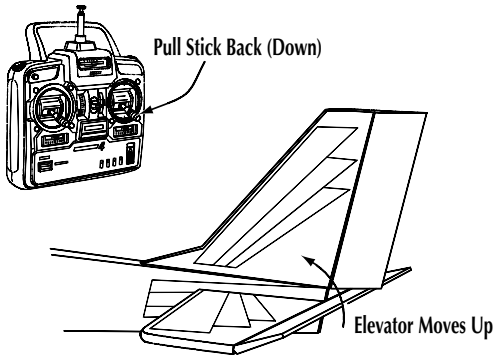

Move the control sticks on the transmitter as shown to be certain the controls on the airplane respond in the correct direction. If any of the controls move the wrong way, use the servo reversing switches on the transmitter to make the controls respond correctly. If necessary, refer to the instructions in the instruction manual that came with your radio to identify and operate the reversing switches.

Note that pulling the elevator stick back moves the elevator up (which, in flight, pushes the tail down, thus raising the nose of the plane to climb). The best way to keep this in mind is to think in terms of a pilot in an actual airplane. He pulls the control stick back to raise the nose of the plane.

CENTER THE CONTROL SURFACES

Even though the trim levers on the transmitter may be used to center the control surfaces, you should start out with the trims centered.

Do the elevator first.



❑ 1. With the transmitter and receiver on, view the elevator and stab from the end. If the elevator is not centered, disconnect the clevis from the control horn on the elevator. Holding the end of the pushrod with pliers, screw or unscrew the clevis as necessary until the elevator will be centered when reconnected to the pushrod. **Note:** Be sure not to unscrew the clevis too far. It must remain securely fastened to the end of the pushrod.

❑ 2. Center the rudder and both ailerons the same way.

❑ 3. Now that the rudder is centered, center the nose wheel by adjusting the pushrod in the threaded connector on the steering arm. Roll the fuselage along a flat surface (such as your garage, basement or kitchen floor) to make certain it rolls straight. This should be done with the transmitter and receiver on. Make adjustments if necessary. Add a small drop of threadlocker to the screw and securely tighten to lock the pushrod into position.

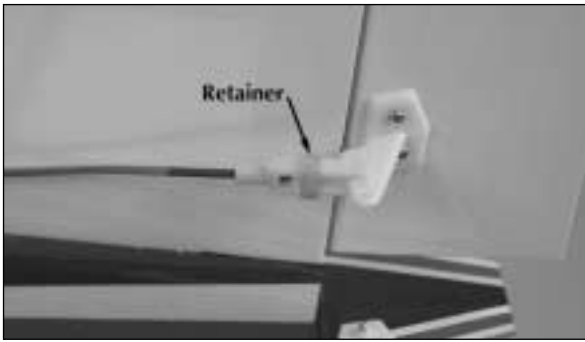

- ❑ 4. Install a silicone retainer on all the clevises (elevator, rudder, ailerons, throttle). If you've misplaced the retainers that came with the model, use 1/4" [6mm] pieces cut from leftover fuel tubing.

ADJUST THE THROTTLE

The throttle is to be set up so that, when the throttle stick is all the way **down** and the throttle trim lever is all the way **up**, the carburetor will be slightly open (so the engine will idle at a low RPM). When the engine is to be shut off, the trim lever is moved down to close the carburetor the rest of the way.

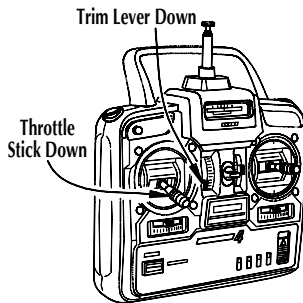

- ❑ 1. With the transmitter and receiver on, move the throttle trim lever and the throttle stick all the way down.

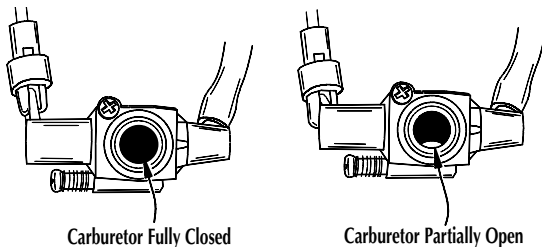

- ❑ 2. Observe the opening in the carburetor. If the carburetor is fully closed, proceed to step 3. If the

carburetor is not fully closed, adjust the pushrod at the connector on the carburetor arm or at the clevis on the servo arm until the carburetor is closed.

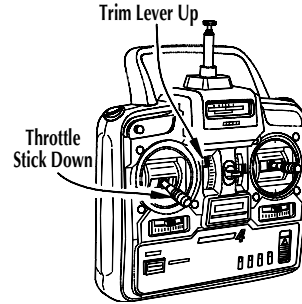

- ❑ 3. Move the throttle trim lever all the way up, but leave the throttle stick all the way down. Now the carburetor should be partially open (about 1/32" to 1/16" [1 to 1.5mm]).

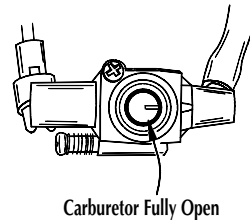

- ❑ 4. Move the throttle stick all the way up. The carburetor should be fully open. If the carb is not fully open, the pushrod travel may have to be increased. This is done by moving the clevis further out on the servo arm (or by moving the pushrod connector closer in on the carburetor arm). Adjust the pushrod as necessary to achieve the correct setup.

SET THE CONTROL THROWS

The control throws are a measure of how far the flight controls (elevator, ailerons, rudder) move up and down (or from side to side). If the controls move too much, the plane will respond too quickly and be difficult to control. If the controls do not move enough, there will not be enough control to fly or land the model. Due to the **great** effect the control throws have on the way a model flies, the control throws **must** be set according to the measurements provided in this manual.

Start with the elevator...

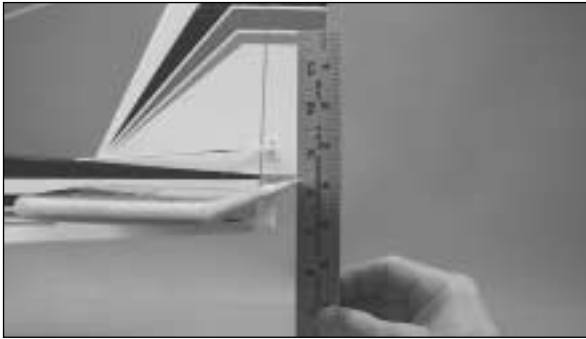

1. Turn on the transmitter and receiver. Holding a ruler up to the trailing edge of the elevator, move the elevator all the way up using the control stick on the transmitter. Measure the distance the elevator moves up. Also move the elevator down and measure the distance. As shown in the chart that follows, the elevator should move up 1/2" [13mm] and down 1/2" [13mm]. If the elevator moves up or down more than 1/2" [13mm], the control throw must be **decreased** by connecting the pushrod to a hole **further out** on the elevator control horn, or by connecting the pushrod to a hole **further in** on the elevator servo arm (as shown in the sketches below). If the elevator moves up and down less than 1/2" [13mm], the control throw must be **increased** by relocating the pushrods the opposite as described.

Control Throws

Elevator:	1/2" [13mm] up	1/2" [13mm] down
Ailerons:	3/8" [10mm] up	3/8" [10mm] down
Rudder:	1" [25mm] right	1" [25mm] left

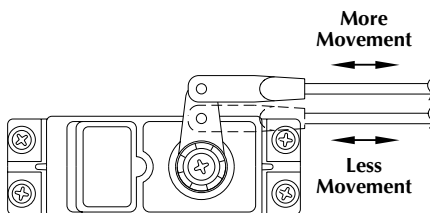

Moving the pushrod outward on the servo arm results in more pushrod movement.

To get more control surface movement, move the pushrod farther out on the servo arm. Moving the pushrod farther inward yields less control surface throw.

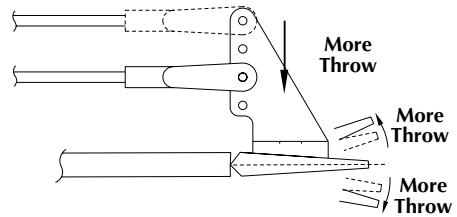

Moving the pushrod inward on the control horn results in more throw.

To get more control surface movement, move the pushrod farther in on the control horn. Moving the pushrod farther out yields less control surface throw.

2. Measure and if necessary, adjust the aileron and rudder control throws the same way.

IDENTIFY YOUR MODEL

Whether you fly at an R/C club or somewhere on your own, you should have your name, telephone number and address in or on your model so it can be identified and returned in case it lands somewhere away from the flying site. Fill out the I.D. tag found at the end of the manual and place it on or inside the model.

BALANCE PROPELLERS

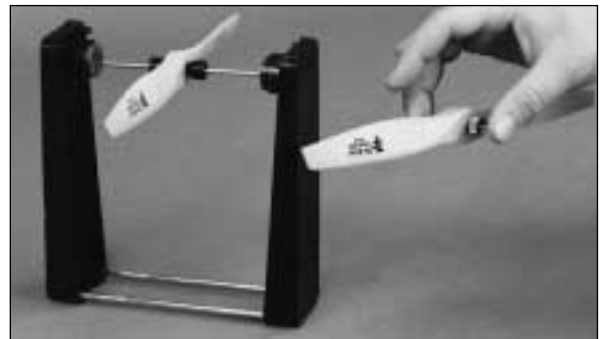

To inexperienced modelers balancing propellers may seem unnecessary. Balancing propellers could be equated to changing the oil in your car every 3000 miles. If not done regularly, the car keeps running, but over time poor maintenance will take its toll. Similarly, the engine will run and the plane will fly even if the propeller is not balanced, but over time, not only may an unbalanced propeller cause engine mounting screws and bolts to loosen, possibly with disastrous effect, but vibration may also damage the radio receiver and battery. Vibration can also cause fuel to foam, which will, in turn, cause the engine to run hot or quit.

If you do not yet have a propeller balancer, ask your flight instructor or another club member if they will help you balance your propellers. We use a Top Flite Precision Magnetic Prop Balancer™ (TOPQ5700) in the workshop and keep a Great Planes Fingertip Prop Balancer (GPMQ5000) in our flight box.

CHECKLIST

Now it's time to do a final check before taking the model to the field. Take the time to do these checks to make certain your model is ready to fly.

- 1. Make certain the screws on all the wheel collars that hold the wheels on are secure. Threadlocker is recommended on the screws.
- 2. Check to see that the screws that hold the servo arms to the servos are present and secure.
- 3. Be certain the silicone retainers on all the nylon clevises are in position.
- 4. Make certain the throttle, elevator, rudder and ailerons respond in the correct direction.
- 5. Make certain the propeller and propeller spinner are secure.
- 6. Balance the model according to the instructions.
- 7. Fill-out and place the I.D. card inside the model.
- 8. Balance the propeller and spare propellers.

CHARGE THE BATTERIES

If you haven't already done so, refer to the instruction manual that came with the radio and charge the batteries in the plane and in the transmitter overnight the night before you go flying.

GATHER YOUR TOOLS

In addition to the engine starting equipment mentioned near the beginning of the manual, you should start a collection of tools that may be required for adjustments and maintenance at the flying field. Following is a list of the most suggested items...

Tools:

- #1 Phillips screwdriver
- #2 Phillips screwdriver
- 5/16" (or 8mm) socket wrench (for glow plug)
- 1.5mm hex wrench (for wheel collars)
- 12mm wrench or crescent wrench (for propeller nut)
- Pliers
- Hobby knife

Spare parts:

- Suitable propellers
- Glow plug
- #64 rubber bands (stored in container with talcum powder or kitty litter)

Flight Preparation

Flight preparation is to be done at the flying field.

IMPORTANT: Your radio control system transmits a signal on a certain frequency. Be certain you know what the frequency is. This is expressed as a two-digit number (42, 56, etc.) and can be found on the container the radio system came in and is also located on the transmitter and receiver. There are many different frequencies, but there is still a chance that someone else at the flying field may be on the same frequency as you. If you turn on your transmitter while that person is flying, a crash will result. **NEVER** turn on your transmitter until you have permission from your instructor and until you have possession of the frequency clip used for frequency control at the flying site.

Be certain your flight instructor performs these following checks with you.

CHECK THE CONTROLS

1. Get the frequency clip from the frequency control board at your flying site.

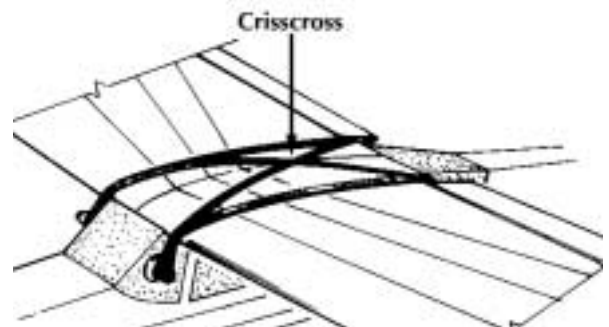

2. Mount the wing to the fuselage with #64 rubber bands. Twelve to fourteen rubber bands are suggested. Be certain the final two are "crisscrossed," thus ensuring that the others remain secure.

Engine Safety Precautions

Failure to follow these safety precautions may result in severe injury to yourself and others.

3. Turn on the transmitter and receiver. One at a time, operate each control on the airplane using the transmitter. Make certain each control is responding correctly. This **must** be done before **every** flight. There are several types of malfunctions that can be discovered by performing this elementary task, thus saving your model!

RANGE CHECK THE RADIO

A range check **must** be performed before the **first** flight of a new model. It is not necessary to do a range check before every flight (but is not a bad idea to perform a range check before the first flight of each day). A range check is the final opportunity to reveal any radio malfunctions and to be certain the system has adequate operational range.

1. **BE CERTAIN** you have the frequency clip.
2. Turn on the transmitter and receiver. Leave the transmitter antenna all the way down. Walk away from the model while simultaneously operating the controls. Have an assistant stand by the model and tell you what the controls are doing to confirm that they operate correctly. You should be able to walk approximately 100 feet from the model and still have control without any “glitching” or inadvertent servo operation.
3. If everything operates correctly, return to the model and start the engine. Perform the range check with your assistant holding the plane with the engine running at various speeds. If the servos chatter or move inadvertently, there may be a problem. **Do not** fly the plane! With the assistance of your instructor, look for loose servo connections or binding pushrods. Also be certain you are the only one on your frequency and that the battery has been fully charged.

GROUND CHECK

If the engine is new, follow the engine manufacturer's instructions to break-in the engine. After break-in, confirm that the engine idles reliably, transitions smoothly and rapidly to full power and maintains full power—indefinitely. After you run the engine on the model, inspect the model closely to make sure all screws remained tight, the hinges are secure, the prop is secure and all pushrods and connectors are secure.

Keep all engine fuel in a safe place, away from high heat, sparks or flames, as fuel is very flammable. Do not smoke near the engine or fuel; and remember that engine exhaust gives off a great deal of deadly carbon monoxide. Therefore do not run the engine in a closed room or garage.

Get help from an experienced pilot when learning to operate engines.

Use safety glasses when starting or running engines.

Do not run the engine in an area of loose gravel or sand; the propeller may throw such material in your face or eyes.

Keep your face and body as well as all spectators away from the plane of rotation of the propeller as you start and run the engine.

Keep these items away from the prop: loose clothing, shirt sleeves, ties, scarfs, long hair or loose objects such as pencils or screwdrivers that may fall out of shirt or jacket pockets into the prop.

Use a “chicken stick” or electric starter to start the engine. Do not use your fingers to flip the propeller. Make certain the glow plug clip or connector is secure so that it will not pop off or otherwise get into the running propeller.

Make all engine adjustments from behind the rotating propeller.

The engine gets hot! Do not touch it during or right after operation. Make sure fuel lines are in good condition so fuel will not leak onto a hot engine, causing a fire.

To stop a glow engine, cut off the fuel supply by closing off the fuel line or following the engine manufacturer's recommendations. Do not use hands, fingers or any other body part to try to stop the engine. Do not throw anything into the propeller of a running engine.

AMA Safety Code (excerpt)

Read and abide by the following Academy of Model Aeronautics Official Safety Code:

GENERAL

1. I will not fly my model aircraft in sanctioned events, air shows, or model flying demonstrations until it has been proven to be airworthy by having been previously successfully flight tested.

2. I will not fly my model aircraft higher than approximately 400 feet within 3 miles of an airport without notifying the airport operator. I will give right of way to and avoid flying in the proximity of full scale aircraft. Where necessary an observer shall be used to supervise flying to avoid having models fly in the proximity of full scale aircraft.

3. Where established, I will abide by the safety rules for the flying site I use and I will not willfully and deliberately fly my models in a careless, reckless and/or dangerous manner.

7. I will not fly my model unless it is identified with my name and address or AMA number, on or in the model.

9. I will not operate models with pyrotechnics (any device that explodes, burns, or propels a projectile of any kind).

RADIO CONTROL

1. I will have completed a successful radio equipment ground check before the first flight of a new or repaired model.

2. I will not fly my model aircraft in the presence of spectators until I become a qualified flier, unless assisted by an experienced helper.

3. I will perform my initial turn after takeoff away from the pit or spectator areas and I will not thereafter fly over pit or spectator areas, unless beyond my control.

4. I will operate my model using only radio control frequencies currently allowed by the Federal Communications Commission...

End of AMA Safety Code

Flying

These flying instructions are **not** an endorsement for learning to fly on your own, but are printed so you can know what to expect and what to concentrate on while learning under the tutelage of your instructor. Further, these flight instructions may be referenced once you finally do begin flying on your own.

IMPORTANT: If you do insist on flying on your own, you **must** be aware of your proximity to R/C club sites. If there is an R/C site within six miles of where you are flying and if you are operating your model on the same frequency as somebody else, there is a **strong** possibility that one or both models will crash due to radio interference. There is **great** potential for an out-of-control model to cause property damage and/or severe personal injury. We **strongly** urge you to fly at a R/C club site where frequency control is in effect so you can be confident you will be the only one flying on your channel.

CAUTION (THIS APPLIES TO ALL R/C AIRPLANES): If, while flying, you notice an alarming or unusual sound such as a low-pitched "buzz," this may indicate control surface *flutter*. Flutter occurs when a control surface (such as an aileron or elevator) or a flying surface (such as a wing or stab) rapidly vibrates up and down (thus causing the noise). In extreme cases, if not detected immediately, flutter can actually cause the control surface to detach or the flying surface to fail, thus causing loss of control followed by an impending crash. The best thing to do when flutter is detected is to slow the model **immediately** by reducing power, then land as soon as safely possible. Identify which surface fluttered (so the problem may be resolved) by checking all the servo grommets for deterioration or signs of vibration. Make certain all pushrod linkages are secure and free of play. If it fluttered once, under similar circumstances it will probably flutter again unless the problem is fixed. Some things which can cause flutter are; Excessive hinge gap; Not mounting control horns solidly; Poor fit of clevis pin in horn; Side-play of wire pushrods caused by large bends; Excessive free play in servo gears; Insecure servo mounting; and one of the most prevalent causes of flutter; Flying an over-powered model at excessive speeds.

TAXIING

Remember, it is assumed that your instructor is operating the model for you.

Before the model is ready for takeoff, it must first be set up to roll straight down the runway. With the engine running at a low idle, place the plane on the runway and, if your flying field permits, stand behind the model. Advance the throttle just enough to allow the model to roll. If the model does not roll straight down the runway, shut the engine off and adjust the nose gear pushrod as necessary. Do not use the rudder trim to correct the nose wheel because this will also affect the rudder. **Note:** Crosswinds may affect the direction the model rolls, so this test should be done in calm conditions, or with the model facing directly into the wind.

TAKEOFF

If possible, takeoff **directly into** the wind. If you are experienced, taking off in a crosswind is permissible (and sometimes necessary—depending upon the prevailing wind conditions and runway heading). Taking off into the wind will help the model roll on a straight path and also reduces ground speed for takeoff. Taxi the model onto the runway or have an assistant carry it out and set it down pointing into the wind down the runway. When ready, gradually advance the throttle while simultaneously using the left stick (rudder/nose wheel) to steer the model. Gain as much speed as the runway and flying site will practically allow before gently applying up elevator, lifting the model into the air. Be ready to make immediate corrections with the ailerons to keep the wings level and be smooth on the elevator stick, allowing the model to establish a gentle climb to a safe altitude before making the first turn (away from yourself). Do not “yank” back the elevator stick forcing the plane into too steep of a climb which could cause the model to quit flying and stall.

FLIGHT

Once airborne, maintain a steady climb and make the initial turn away from the runway. When at a comfortable, safe altitude throttle back to slow the model, thus giving you time to think and react. The Hobbistar .60 MKIII should fly well at half or even slightly less than half-throttle. Adjust the trims so the plane flies straight and level at your “cruise” throttle setting. After flying around for a while and while still at a safe altitude with plenty of fuel, practice slow flight and execute practice landing approaches by reducing the throttle further to see how the model handles when coming in to land. Add power to see how the model climbs as well. Continue to fly around while learning how the model responds. Mind your fuel level, but use this first flight to become familiar with the model before landing.

LANDING

When ready to land, pull back the throttle stick fully while flying downwind just before making the 180-degree turn toward the runway. Allow the nose of the model to pitch downward to gradually bleed off altitude. Continue to lose altitude, but maintain airspeed by keeping the nose down while turning. Apply up elevator to level the plane when it reaches the end of the runway and is about five to ten feet off the ground. If the model is too far away, carefully add a small amount of power to fly the model closer. If going too fast, smoothly advance the throttle and allow the model to gain airspeed, then apply elevator to climb-out and go around to make another attempt. When finally ready to touch down, continue to apply up elevator, but not so much that the airplane will climb. Continue to apply up elevator while the plane descends until it gently touches down.

After you have landed and shut the engine off, adjust the pushrods on the ailerons, elevator and rudder as necessary so the trim levers on the transmitter may be returned to center (this will not be required on any of the controls that did not need trim adjustments).

Maintenance Tips

1. After flying for the day, don't forget to use your fuel pump to drain excess fuel from the tank.
2. Do not reuse torn or oily rubber bands. Purchase spare rubber bands (HCAQ2020, 1/4 lb box). After flying, oily rubber bands should be stored in a container with talcum powder or kitty litter. This will absorb oil and keep the rubber bands fresh for the next flying session.
3. After each day's flying, use spray cleaner and paper towels to **thoroughly** clean the model.

This model belongs to:	Name
	Address
	City, State Zip
	Phone number
	AMA number