

HOBBIKO
SUPERSTARTM EP
Almost Ready-to-Fly Electric R/C Trainer
WITH AILERONS

ASSEMBLY INSTRUCTIONS

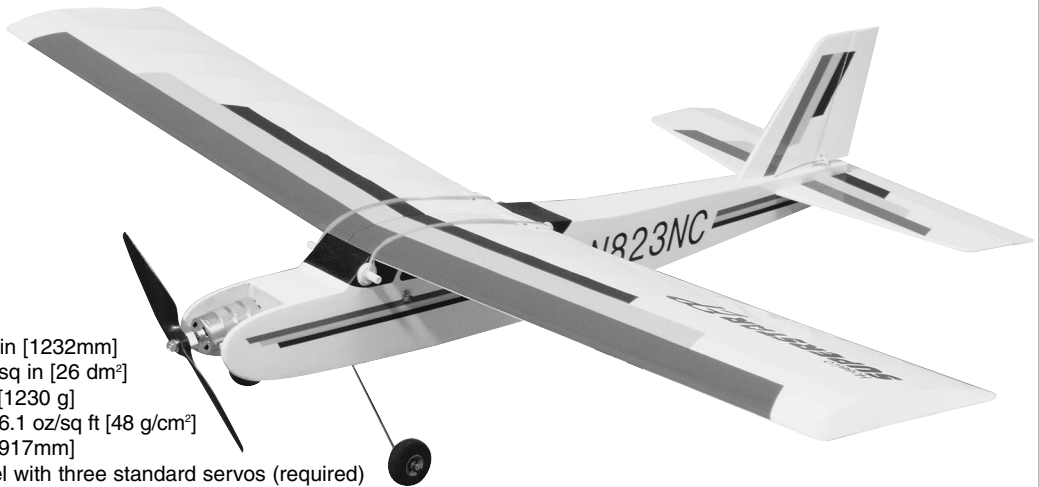

Wingspan: 48.5 in [1232mm]
Wing Area: 400 sq in [26 dm²]
Weight: 43.5 oz [1230 g]
Wing Loading: 16.1 oz/sq ft [48 g/cm²]
Length: 36.1 in [917mm]
Radio: 4-Channel with three standard servos (required)
Motor: Included
Electronic Speed Control: Included
Motor Battery: 8.4 volt 1700mAh – 3000mAh

90-DAY LIMITED WARRANTY

If you, as the original owner of this model, discover defects in parts and workmanship within 90 days of purchase, Hobbico will repair or replace it – at the option of our authorized U.S. repair facility, Hobby Services – without charge. Our liability does not include the cost of shipping to us. However, Hobby Services will pay shipping expenses to return your model to you. You must provide proof of purchase, such as your original purchase invoice or receipt, for your model's warranty to be honored. This warranty does not apply to damage or defects caused by misuse or improper assembly, service or shipment. Modifications, alterations or repair by anyone other than Hobby Services voids this warranty. We are sorry, but we cannot be responsible for crash damage and/or resulting loss of kits, motors, accessories, etc.

Your SuperStar EP ARF must be returned directly to Hobby Services for warranty work. The address is: **Hobby Services, Attn: Service Department, 1610 Interstate Drive, Champaign, IL 61822-1067. Phone: (217) 398-0007.** Please follow the instructions below when returning your model. This will help our experienced technicians to repair and return it as quickly as possible.

1. ALWAYS return your entire system, including airplane and radio.
2. Disconnect the receiver battery switch harness and make sure that the transmitter is turned off. Disconnect all batteries.
3. Include a list of all items returned and a THOROUGH, written explanation of the problem and service needed. If you expect the repair to be covered under warranty, also include your proof of purchase.
4. Include your full return address and a phone number where you can be reached during the day.

If your model is past the 90 day warranty period or is excluded from warranty coverage, you can still receive repair service through Hobby Services at a nominal cost. Repair charges and postage may be prepaid or billed COD. Additional postage charges will be applied for non-warranty returns. All repairs shipped outside the United States must be prepaid in U.S. funds only. All pictures, descriptions and specifications found in this instruction manual and on the product package are subject to change without notice. Hobbico maintains no responsibility for inadvertent errors.

Table of Contents

Introduction	2
Safety Precautions	2
Decisions You Must Make	3
Radio Equipment.....	3
Battery Selection	3
Chargers.....	4
Additional Items Required	4
Tools	4
Optional Supplies and Tools.....	4
Important Building Notes	4
Kit Contents	5
Ordering Replacement Parts	6
Common Abbreviations	6
Assemble the Wing	7
Install the Stabilizer and Fin	9
Install the Landing Gear	10
Install the Battery Hatch Cover	11
Install the Wing Dowels	12
Install the Radio	12
Get the Model Ready to Fly	15
Check the Control Directions	15
Set the Control Throws.....	15
Install the Propeller and Motor Battery	16
Install the Wing on the Fuselage	16
Balance the Model (C.G.)	17
Balance the Model Laterally	17
Proper Care of Your Motor	18
Performance Tips	18
Preflight	18
Identify Your Model.....	18
Charge the Batteries	18
Balance Propellers.....	18
Ground Check	19
Range Check.....	19
AMA Safety Code (excerpt)	19
Check List	19
Flying	Back Cover
Takeoff	Back Cover
Flight	Back Cover
Landing	Back Cover

Introduction

Many modelers have learned how to fly with the stable, easy to fly, glow powered SuperStar ARF. Hobbico has taken that stability and ease of flight and produced an electric version. No more fuel bottle, starter, glow driver or noise. All you need to take with you to the flying field is the plane, transmitter, batteries and charger. When you're done flying, just remove the motor battery and put the plane away until the next flying session. No more wiping fuel residue off the plane at the end of the day. So, if you are ready to get started in the exciting world of electric flight, let's get this bird in the air.

An electronic speed control with BEC (Battery Eliminator Circuit) is included with the SuperStar EP. The BEC eliminates the need for a receiver battery. The electronic speed control provides power for the receiver by using the motor battery. As the motor runs, the voltage of the motor battery is reduced. The electronic speed control has a preset voltage. Once the motor battery reaches it, the electronic speed control switches the motor off. This leaves enough power in the motor battery to operate the receiver so that the SuperStar EP can be landed safely.

For the latest technical updates or manual corrections for the SuperStar EP, visit the web site listed below and select the Hobbico SuperStar EP. A "tech notice" box will appear in the upper left corner of the page if there is new technical information or changes to this kit.

<http://www.hobbico.com/airplanes/index.html>

Protect Your Model, Yourself & Others Follow these Important Safety Precautions

1. Your SuperStar EP should not be considered a toy, but rather a sophisticated, working model that functions very much like a full-size airplane. Because of its performance capabilities, the SuperStar EP, if not assembled and operated correctly, could possibly cause injury to yourself or spectators and damage to property.

2. You must assemble the model **according to the instructions**. Do not alter or modify the model, as doing so may result in an unsafe or unflyable model. In a few cases the instructions may differ slightly from the photos. In those instances the written instructions should be considered as correct.

3. You must take time to build **straight, true and strong**.

4. You must use an R/C radio system that is in first-class condition with the appropriate size servos.

5. You must correctly install all R/C and other components so that the model operates correctly on the ground and in the air.

6. You must check the operation of the model before **every** flight to insure that all equipment is operating and that the model has remained structurally sound. Be sure to check clevises or other connectors often and replace them if they show any signs of wear or fatigue.

7. If you are not already an experienced R/C pilot, you should fly the model only with the help of a competent, experienced R/C pilot.

We, as the kit manufacturer, provide you with a top quality kit and instructions, but ultimately the quality and flyability of your finished model depends on how you build it; therefore, we cannot in any way guarantee the performance of your completed model and no representations are expressed or implied as to the performance or safety of your completed model.

Remember: Take your time and follow the instructions to end up with a well-built model that is straight and true.

If you have not flown this type of model before, we recommend that you get the assistance of an experienced pilot in your R/C club for your first flights. If you're not a member of a club, your local hobby shop has information about clubs in your area whose membership includes experienced pilots.

In addition to joining an R/C club, we strongly recommend you join the AMA (Academy of Model Aeronautics). AMA membership is required to fly at AMA sanctioned clubs. There are over 2,500 AMA chartered clubs across the country. Among other benefits, the AMA provides insurance to its members who fly at sanctioned sites and events. Additionally, training programs and instructors are available at AMA club sites to help you get started the right way. Contact the AMA at the address or toll-free phone number below:



Academy of Model Aeronautics
5151 East Memorial Drive
Muncie, IN 47302-9252
Tele. (800) 435-9262
Fax (765) 741-0057

Or via the Internet at: <http://www.modelaircraft.org>

Decisions You Must Make

This is a partial list of items required to finish the SuperStar EP that may require planning or decision making before starting to build. Order numbers are provided in parentheses.

Radio Equipment

A 4-channel radio system with 3 standard servos is required.

Battery Selection

The SuperStar EP was designed to fly on the recommended 7-cell, 8.4 volt, 2100 mAh motor battery pack. If you are new to electric airplanes (or even cars and boats) here is a short explanation of rechargeable NiCd (Nickel Cadmium) and NiMH (Nickel-Metal Hydride) batteries. A single cell rechargeable battery supplies 1.2 volts with no load (not powering anything). A 7-cell battery pack can supply 8.4 volts (1.2 volts x 7 cells = 8.4 volts). The cell rating in mAh (milli-amp-hours) is the amount of current the battery can supply. If a battery is rated at 2100 mAh, the battery can supply 2.1 amps for 1 hour. This sounds great, flying for an hour on a single

battery charge! The bad news is that to produce the power needed to fly an airplane the size of the SuperStar EP, the motor draws from 15-25 amps. The current consumption reduces the run time to 5-8 minutes. The good news is that propellers become more efficient as the speed of the plane increases. This lowers the current draw, allowing the plane to fly longer on a single charge, sometimes up to 20% longer. Also, with an electronic speed control, the motor can be throttled back, increasing the flight time. Most airplanes only need full throttle during takeoff and climbing maneuvers.

Chargers

A fully charged battery pack will provide an initial “surge” of power during the first 15 to 30 seconds of the motor run. Then the power output stays fairly steady for the next several minutes before dropping off quickly. If you do not charge your battery completely, it will not deliver that surge necessary for a good takeoff and climb out. There are at least three ways to “peak-charge” your battery pack.

1. The easiest way is with a “peak-detecting” battery charger. This type of charger will automatically charge your battery until it is fully charged.
2. The second method of charging your motor batteries is to monitor the voltage of your battery pack with a voltmeter. Your charger may have sockets into which you may plug a voltmeter. If not, you may insert the probes from the voltmeter into the rear of the battery plug, making contact with the metal contacts. As your battery charges, the voltage will gradually increase. When the battery is fully charged, the voltage will start to **drop**. At this point your battery is fully charged.
3. The third (and least reliable) method of peak-charging your battery pack is by checking its temperature. As the battery charges it will remain cool until it is fully charged. When it reaches the fully charged state, it will rapidly build up heat. You can feel this heat with your hand. As soon as the pack starts to noticeably warm up, disconnect it from the charger. **Do not continue charging if the battery pack is hot!** Overcharging will damage your battery pack and can result in an explosion.

Additional Items Required

Tools

In addition to common household tools and hobby tools, this is the “short list” of the most important items required to build the SuperStar EP.

- Hobby knife (HCAR0105)
- #11 blades (HCAR0211)
- Small Phillips and flat blade screwdrivers
- Pliers (HCAR0630)
- Crescent wrench
- Drill with a 1/32" (.8mm) and 3/32" (2.4mm) drill bit

Optional Supplies and Tools

Here is a list of optional tools that will help you build the SuperStar EP.

- Great Planes CG Machine™ (GPMR2400)
- Great Planes AccuThrow™ Deflection Gauge (for measuring control throws, GPMR2405)

Important Building Notes

- **Photos** and **sketches** are placed **before** the step they refer to. Frequently you can study photos in following steps to get another view of the same parts.
- Should repairs ever be required, the SuperStar EP's covering can be patched with Top Flite® MonoKote® purchased separately. MonoKote is packaged in six-foot rolls, but some hobby shops also sell it by the foot. If only a small piece of MonoKote is needed for a minor patch, perhaps a fellow modeler would give you some. MonoKote is applied with a model airplane covering iron, but in an emergency a regular iron could be used.

Kit Contents

Before starting to build, use the **Kit Contents** list to take an inventory of this kit to make sure it is complete and inspect the parts to make sure they are of acceptable quality. If any parts are missing or are not of acceptable quality, or if you need assistance with assembly, contact **Hobbico Product Support**. When reporting defective or missing parts, use the part names exactly as they are written in the Kit Contents list on this page.

Hobbico Product Support
 Phone: (217) 398-8970
 Fax: (217) 398-7721
 E-mail: airsupport@hobbico.com

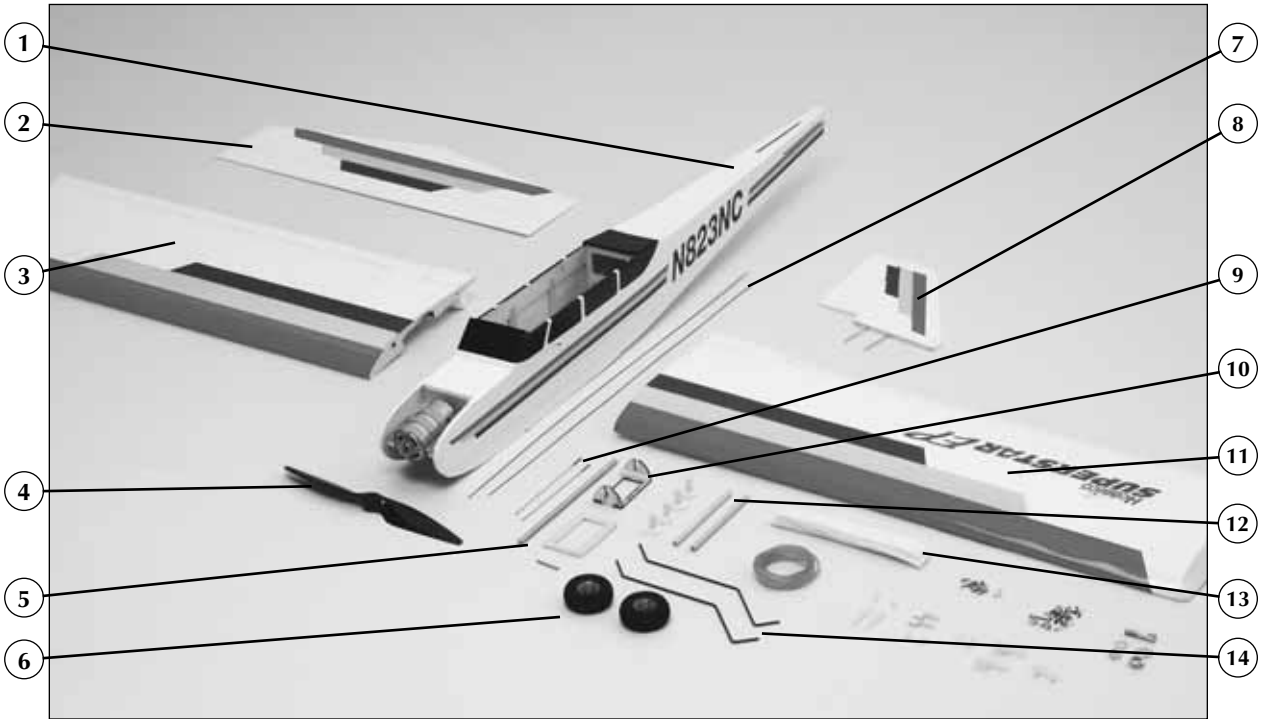

Parts (Photographed)

1. Fuselage w/Motor (1) 2. Stabilizer and Elevator (1) 3. Right Wing w/ailerons (1) 4. 9 x 5.5 Propeller (1) 5. Steel Wing Joiner Rod (1)	6. Foam Wheels (2) 7. 1mm x 520mm Pushrods (2) 8. Fin and Rudder (1) 9. Aileron Pushrod Wires (2) 10. Aileron Servo Tray (1)	11. Left Wing w/ailerons (1) 12. Wing Dowels (2) & Caps (4) 13. Hook and Loop Material (4) 14. Main Landing Gear Wires (2)
--	---	---

Parts (Not Photographed)

(1) 2.5mm x 25mm Alignment Pin (8) Rubberbands (2) Nylon Landing Gear Straps (2) Small Nylon Control Horns (1) Nylon Tail Skid (2) Brass Screw-lock Pushrod Connectors	(2) Nylon Screw-lock Connector Retainers (2) 4-40 x 1/4" Pan Head Screws (4) 3/32" Wheel Collars (5) 2.5mm x 8mm Sheet Metal Screws (1) Aluminum Battery Hatch Retainer (4) 2-56 x 5/8" Machine Screws	(4) 4-40 Set Screws (2) 2-56 Nuts (2) #2 Washers (1) Wing Joiner Tape (1) Electronic Speed Control (1) Prop Adapter (1) Steel Anti-Rotate Pin
---	---	--

Ordering Replacement Parts

To order replacement parts for the Hobbico SuperStar EP, use the order numbers in the **Replacement Parts List** that follows. Replacement parts are available only as listed. Not all parts are available separately (a rudder cannot be purchased separately, but is only available with the tail set). Replacement parts are not available from Product Support, but can be purchased from hobby shops or mail order/Internet order firms. Hardware items (screws, nuts, bolts) are also available from these outlets. If you need assistance locating a dealer to purchase parts, visit www.hobbico.com and click on "Where to Buy." If this kit is missing parts, contact **Hobbico Product Support**.

<u>Item</u>	<u>Description</u>	<u>How to Purchase</u>
Missing pieces		Contact Product Support
Plans	Construction Plans	Plans are not available for ARF models
Hardware	Individual hardware items	Contact your hobby supplier
HCAA3034	SuperStar EP Wing w/ail Kit	Contact your hobby supplier
HCAA3036	SuperStar EP Fuse Kit	Contact your hobby supplier
HCAA3037	SuperStar EP Tail Set	Contact your hobby supplier
HCAA3039	Motor	Contact your hobby supplier
HCAA3040	Prop / Prop Adapter	Contact your hobby supplier
HCAA3041	Electronic Speed Control	Contact your hobby supplier
HCAA3038	SuperStar EP Landing Gear	Contact your hobby supplier

Warning: The motor, electronic speed control, and prop supplied with the SuperStar EP are a matched set and must be used together. Should you choose to change one or more of the supplied components, you will void your warranty on this product.

Metric Conversions

1/64" = .4mm	3/16" = 4.8mm	1" = 25.4mm	18" = 457.2mm
1/32" = .8mm	1/4" = 6.4mm	2" = 50.8mm	21" = 533.4mm
1/16" = 1.6mm	3/8" = 9.5mm	3" = 76.2mm	24" = 609.6mm
3/32" = 2.4mm	1/2" = 12.7mm	6" = 152.4mm	30" = 762mm
1/8" = 3.2mm	5/8" = 15.9mm	12" = 304.8mm	36" = 914.4mm
5/32" = 4mm	3/4" = 19mm	15" = 381mm	

To convert inches to millimeters, multiply inches by 25.4

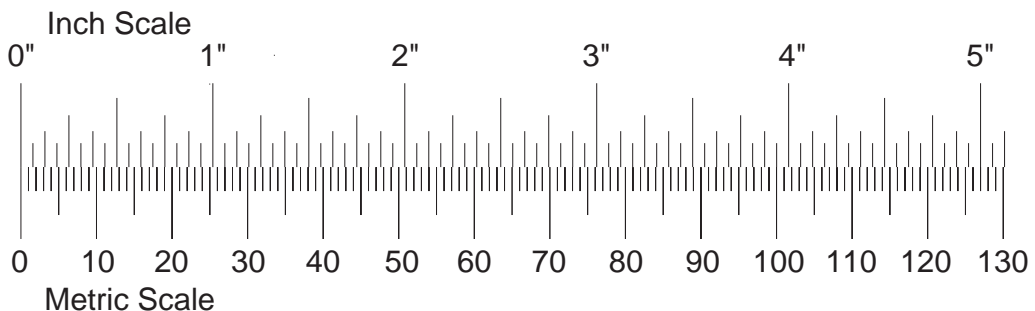

Assemble the Wing

❑ 1. Remove the tape and separate the ailerons from the wing and the elevators from the stab. Use a covering iron with a covering sock on high heat to tighten the covering if necessary. Apply pressure over sheeted areas to thoroughly bond the covering to the wood.

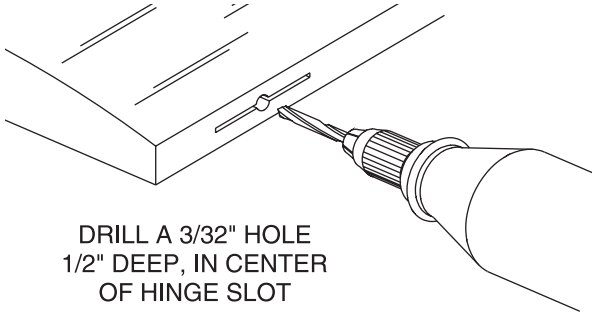

❑ 2. Drill a 3/32" hole, 1/2" deep in the center of each hinge slot to allow the CA to "wick" in. Follow-up with a #11 blade to clean out the slots. Hint: If you have one, use a high-speed rotary tool to drill the holes.

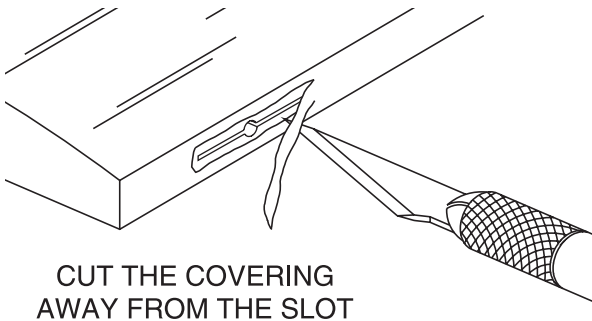

❑ 3. Use a sharp #11 blade to cut a strip of covering from the hinge slots in the wing and aileron.

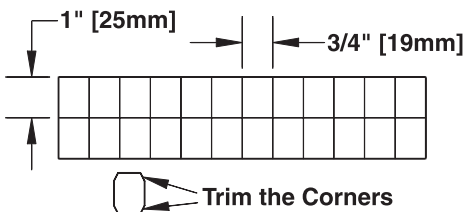

❑ 4. Cut eight 3/4" x 1" [25mm] hinges from the CA hinge strip. Snip off the corners so they go in easier.

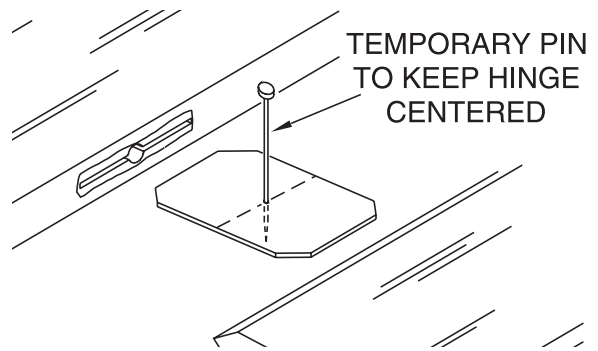

❑ 5 Test fit the ailerons to the wing with the hinges. If the hinges don't remain centered, stick a pin through the middle of the hinge to hold it in position.

❑ 6. Remove any pins you may have inserted into the hinges. Adjust the aileron so there is a small gap between the LE of the aileron and the wing. The gap should be small, just enough to see light through or to slip a piece of paper through.



❑ 7. Apply six drops of thin CA to the top and bottom of each hinge, waiting a few seconds between drops to allow the CA to soak in. Do not use CA accelerator. After the CA has fully hardened, test the hinges by pulling on the aileron.

❑ 8. Repeat steps 1- 6 for the left wing panel.

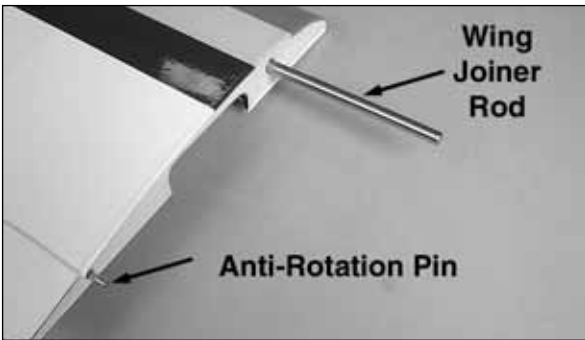

- ❑ 9. Insert the $7/32$ " x $6-7/8$ " [5.5mm x 174.6mm] **steel wing joiner rod** in the forward hole in the wing root rib of the left wing half. Insert the $3/32$ " x 1" [2.3mm x 25.4mm] anti-rotation pin in the aft hole in the wing root rib.



- ❑ 10. Join the two wing halves together.

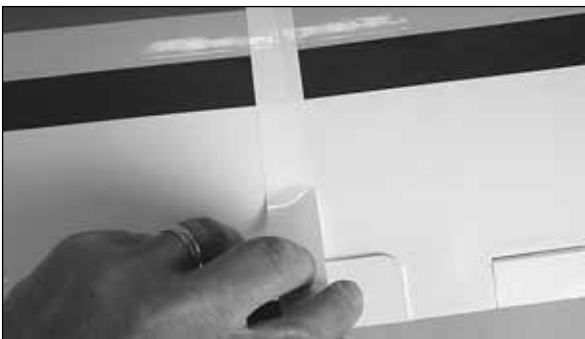

- ❑ 11. On the top and bottom of the wing, apply the 1" [25.4mm] wide **wing joiner tape**, centering on the joint between the two wing halves.

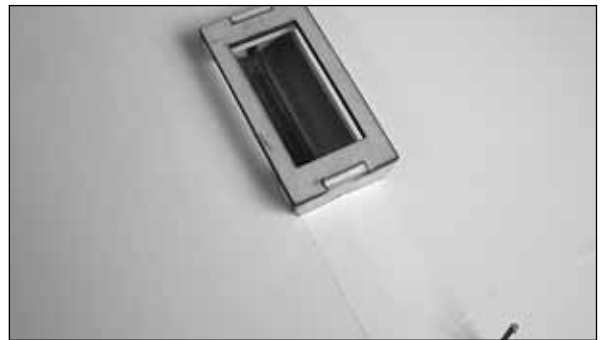

- ❑ 12. Glue the aileron servo tray onto the tabs in the servo opening.

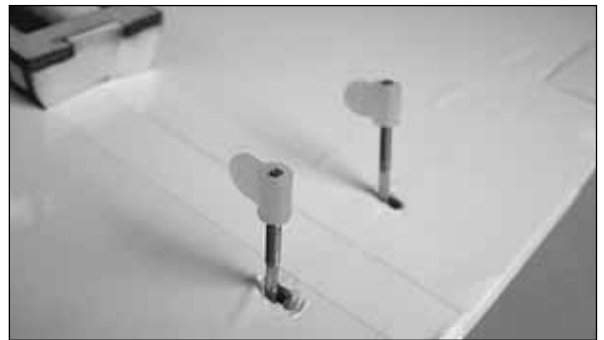

- ❑ 13. Screw the aileron torque rod horns onto the aileron torque rod wires.



- ❑ 14. Place the servo into the servo tray. Drill a $1/16$ " [1.6mm] hole through each of the mounting holes and secure the servo to the tray with the hardware provided with the servo.

❑ 15. Locate two .074" x 6" [.074" x 152mm] pushrod wires. Screw a nylon clevis onto the threaded end of the wires 20 full turns. Install a silicone clevis keeper onto the clevis and then install the clevis in the hole in the aileron torque rod horns.

❑ 16. Ensure that the aileron servo is centered. Enlarge the outermost holes in the servo arm with a Hobbico Servo Horn Drill (or a #48 or 5/64" [2mm] drill bit). Center the aileron and align the wire pushrod with the hole in the end of the servo arm. Using a marker, mark the location where the wires align with the hole in the servo arm. On that mark make a 90 degree bend. From the bend measure an additional 3/16" [4.8mm]. Then, cut off the excess pushrod wire.

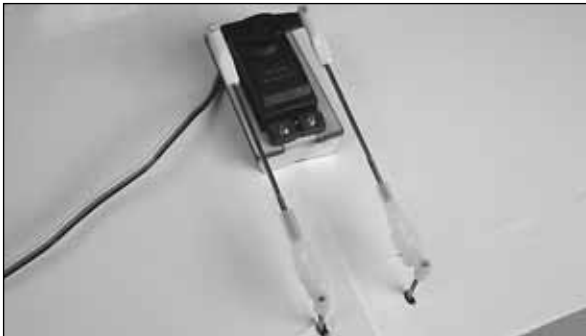
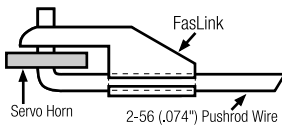

❑ 17. Install the wire into the hole in the servo arm using a nylon FasLink as shown in the sketch.

Install the Stabilizer and Fin

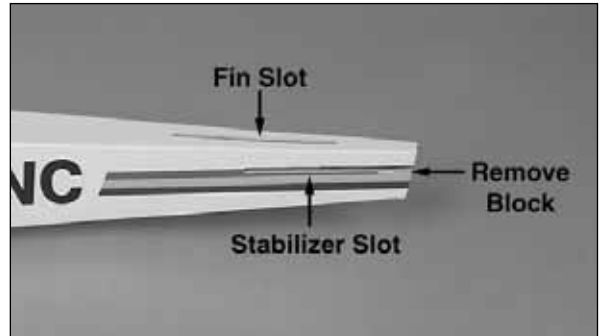

❑ 1. Use a sharp hobby knife to trim the covering from the slots for the stabilizer and fin at the aft end of the **fuselage**. You can feel the slots for the stabilizer on both sides of the fuselage. The slot is located close to the red stripe. Also cut the wood block from the aft end of the slots. The slot for the fin is in the top of the fuselage.

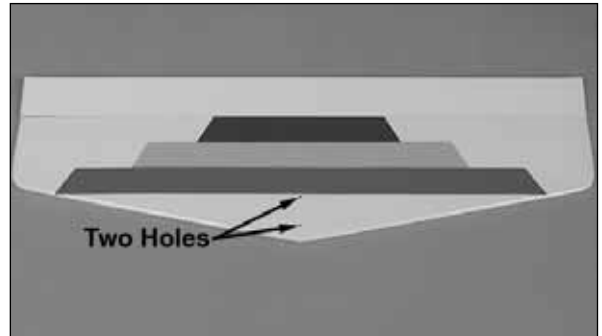

❑ 2. Use a sharp hobby knife to trim the covering from the two holes at the front of the **stabilizer**.

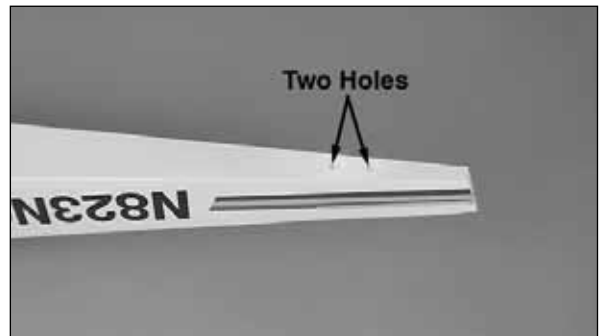

❑ 3. Use a sharp hobby knife to trim the covering from the two holes on the bottom aft end of the fuselage.



❑ 4. Insert the stabilizer and center it in the stabilizer slot. The side with the red, yellow and blue stripe faces upward. The two holes through the stabilizer should be aligned with the fin slot in the top of the fuselage.

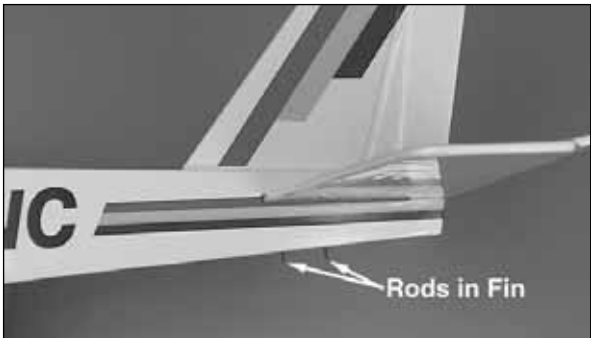

❑ 5. Insert the fin in the fin slot. The two threaded rods go through the two holes in the stabilizer and out the two holes in the bottom of the fuselage.

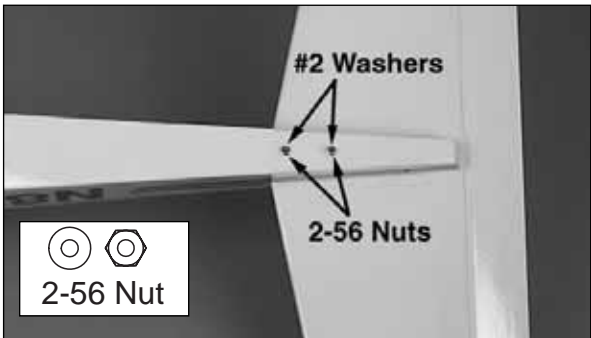

❑ 6. Place a **#2 washer** over each fin rod and secure the fin to the fuselage with **#2-56 nuts**. Do not overtighten the nuts and crush the wood. The nuts should be just tight enough to prevent the stabilizer from moving side to side.

Install the Landing Gear

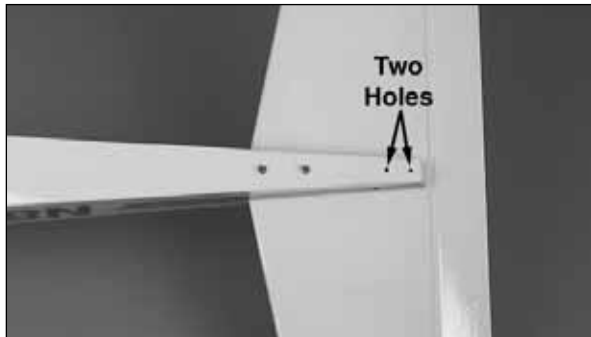

❑ 1. On the bottom of the fuselage, at the aft end, are two small holes. Remove the covering from these holes with a hobby knife.

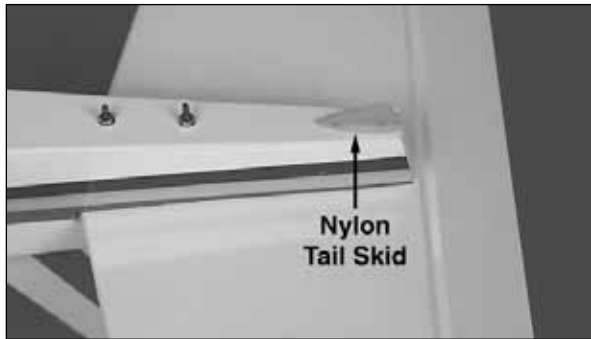

❑ 2. Insert the nylon **tail skid** in the holes. If the tail skid fits loosely, a drop of glue in each hole will secure the tail skid.



❑ 3. Insert the two **main landing gear wires** in the holes, in the slot, at the front of the fuselage.

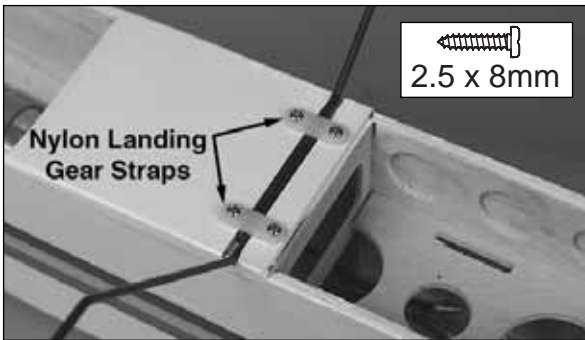

❑ 4. Secure the main landing gear wires to the fuselage with two nylon **landing gear straps** and four 2.5mm x 8mm sheet metal screws. **Note:** The pilot holes are predrilled under the covering and the covering only needs to be pierced.

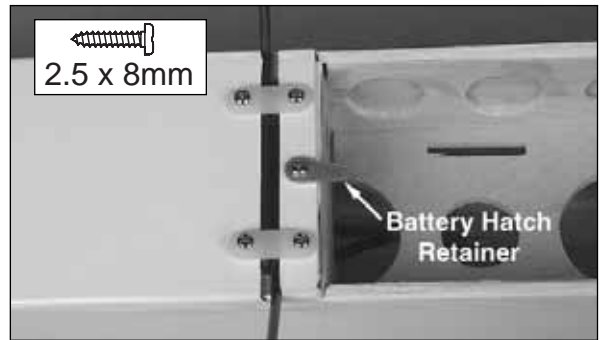

❑ 2. Use a 2.5mm x 8mm sheet metal screw to attach the aluminum **battery hatch retainer** to the fuselage at the front of the battery hatch. Note that the pilot hole for the screw has been drilled under the covering and the covering only needs to be pierced. Tighten the screw completely, then back it off 1/8 of a turn. The hatch retainer should require some pressure to rotate it. If it is too loose, it may rotate during flight, allowing the battery hatch to come off.

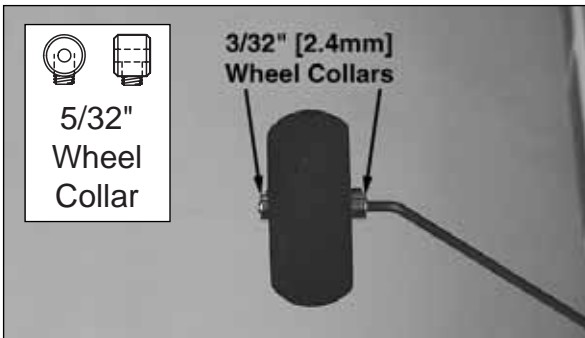

❑ 5. Slide a 3/32" [2.4mm] **wheel collar** on one of the landing gear wires, followed by a **wheel** and a second wheel collar. Secure the wheel collars to the landing gear wires with **4-40 set screws**. Repeat the process for the second landing gear wire. Make sure the wheels rotate freely.



❑ 3. To make the **battery straps**, overlap the hook and loop material by approximately 2" [50.8mm]. Insert the battery straps, from the inside the fuselage, through the slot in one side of the battery tray and back out the slot on the other side of the battery tray. Install a front and back battery strap.

Install the Battery Hatch Cover



❑ 1. The **battery hatch cover** has holes cut in the plywood. Use a hobby knife with a sharp blade to trim the covering from over the holes.

Install the Wing Dowels



❑ 1. Trim the covering from over the wing dowel holes on both sides of the fuselage. The holes are located at the front and back of the wing saddle.

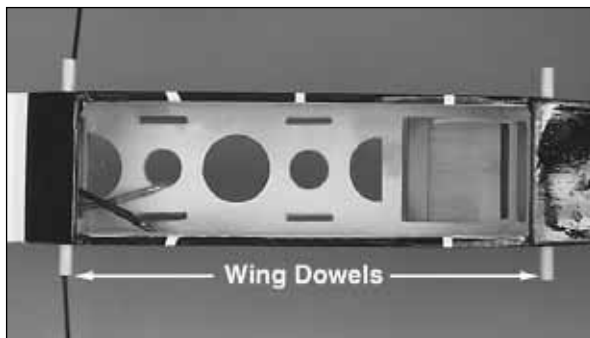

❑ 2. Insert and center the 1/4" x 4" [6.4mm x 101mm] **wing dowels** in the holes in the fuselage.

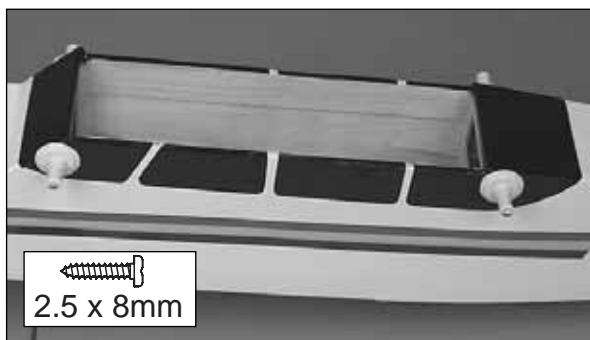

❑ 3. Slide a plastic dowel cap over one end of the wing dowel. Secure the **dowel cap** with a 2.5mm x 8mm sheet metal screw. Install the other three dowel caps and secure them with 2.5mm x 8mm sheet metal screws.

Install the Radio

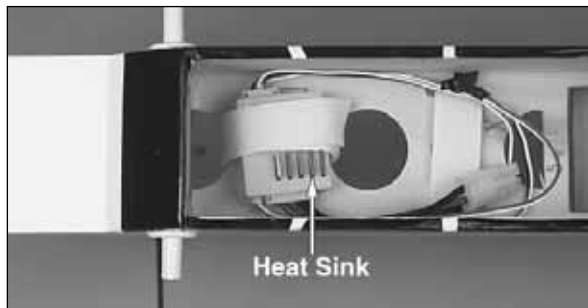

❑ 1. Make a strap, the same way you made the battery strap. Route the strap through the front hole in the battery tray and back through the middle hole. Position the **electronic speed control (ESC)** on the battery tray and secure it with the strap, leaving the metal heat sink exposed. Trim off the excess strap.

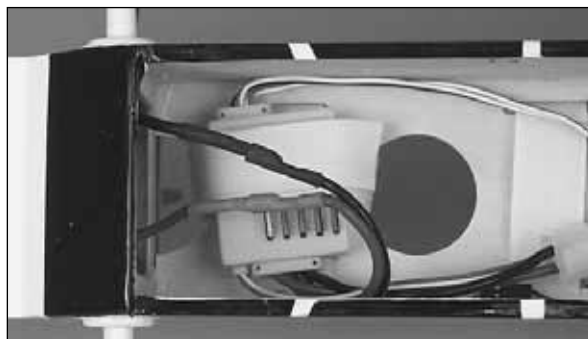

❑ 2. Connect the red and black wires from the motor to the red and black wires from the electronic speed control. Make sure the wires are securely connected. If any of the metal connector is visible, wrap it in electrical tape to prevent the wires from shorting and damaging the electronic speed control.



❑ 3. Install the on/off switch in the opening under the second window on the left side of the fuselage.

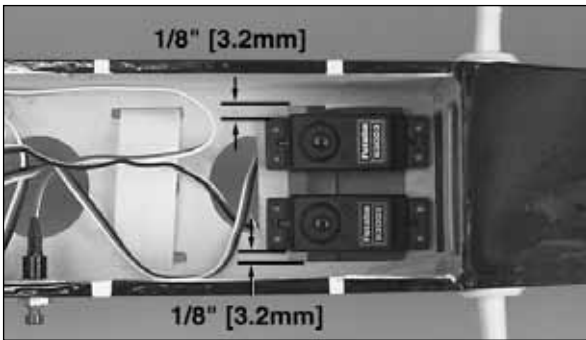

❑ 4. Follow the instructions that came with your radio system to properly install the rubber grommets and metal eyelets on your servos. Place two servos in the servo tray as shown. Position them so that they are approximately 1/8" [3.2mm] from the side of the servo tray.

❑ 5. Drill a 1/32" [.8mm] pilot hole through the servo tray at each grommet. Secure the servos to the servo tray using the screws included with the radio system.

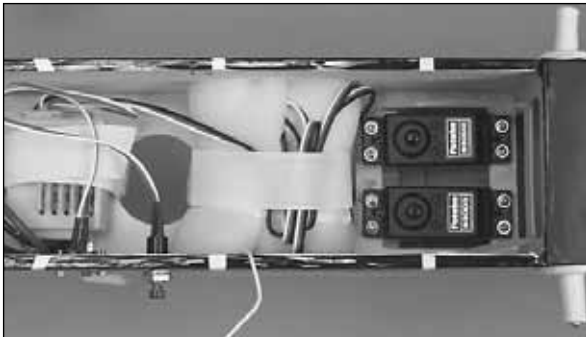

❑ 6. Make a fourth strap, the same way you made the two battery straps. Route the strap through the back hole in the battery tray and back through the middle hole. Plug the two servos and the electronic speed control into the receiver. Wrap the receiver in foam rubber and position it on the battery tray, securing it with the strap. Trim off the excess strap.

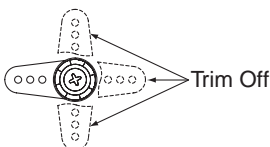

❑ 7. Trim two servo horns so that one arm remains as shown. Keep one of the arms that you trimmed off for an antenna strain relief that will be installed later.

❑ 8. Connect the charged motor battery to the electronic speed control. Switch on the transmitter and then the electronic speed control. Center the rudder and elevator trims on your transmitter.

IMPORTANT: To avoid accidents, do not install the propeller until after all the control checks have been completed.

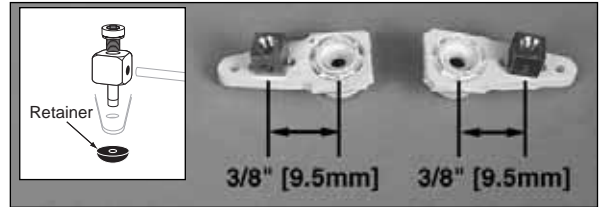

❑ 9. In both servo arms, install a **screw-lock pushrod connector body** in the hole approximately 3/8" [9.5mm] from the center. Press a nylon **retainer** on to the pushrod connector to secure it to the servo arm. **Note:** The servo arms have been painted white for better clarity in the instructions.

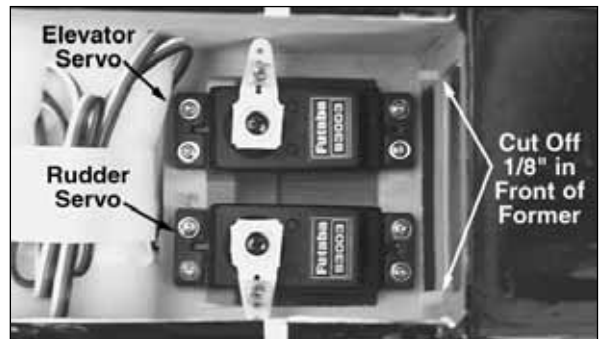

❑ 10. Install the servo arms on the rudder and elevator servos so that they are perpendicular to the centerline of the servo. Also use a hobby knife to trim the outer pushrod tubes approximately 1/8" [3.2mm] in front of the former.

❑ 11. Separate the **back plate** from one of the small nylon **control horns**.



❑ 12. Install the z-bend of one of the pushrods in the outer hole of the control horn.

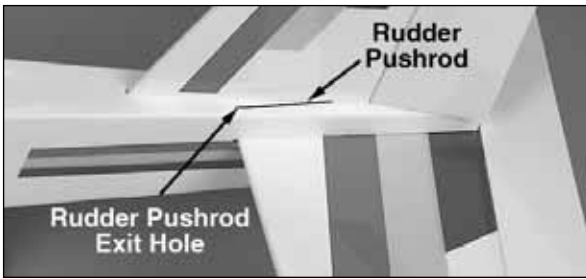

❑ 13. Locate and pierce the covering from the rudder pushrod exit hole on the top of the fuselage, left of the fin. **Note:** An easy method to locate the exit hole under the covering is to insert the wire pushrod into the outer pushrod tube just behind the rudder servo and note where the pushrod wire comes out under the covering.

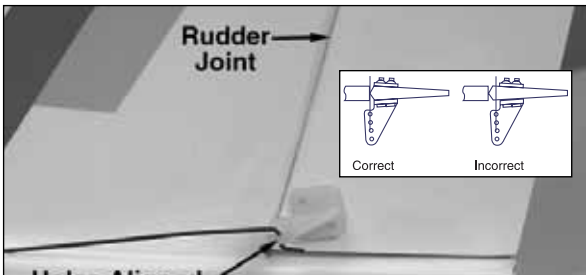

❑ 14. From the aft end of the model, reinsert the pushrod wire with the control horn on it into the rudder outer pushrod tube. Guide the end of the pushrod through the screw-lock pushrod connector on the rudder servo. Position the control horn on the leading edge of the rudder so that the pushrod holes are aligned with the joint between the rudder and fin. If it is not aligned properly with the joint, the plane will turn better one way than the other.

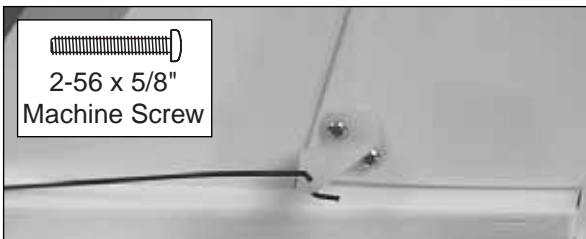

❑ 15. Mark the two control horn mounting hole locations. Move the control horn out of the way and drill a 3/32" [2.4mm] hole through the rudder, at both hole locations. Insert two 2-56 x 5/8" machine screws through the control horn and the rudder. Install the control horn back plate on the other side of the rudder.

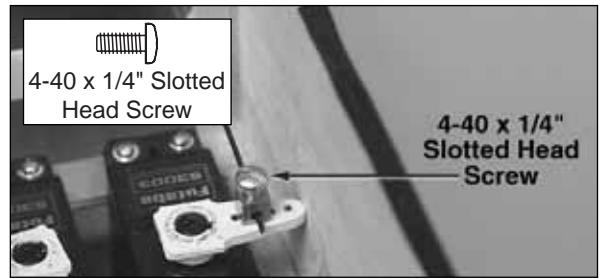

❑ 16. With the transmitter and electronic speed control switched on, set the rudder to neutral (straight with the fin). Secure the rudder pushrod in the screw-lock pushrod connector with a 4-40 x 1/4" slotted head screw. Cut off the excess pushrod.

❑ 17. Repeat the same process to install the elevator pushrod and control horn. The exit hole for the elevator pushrod is on the right side of the fuselage, under the stabilizer.

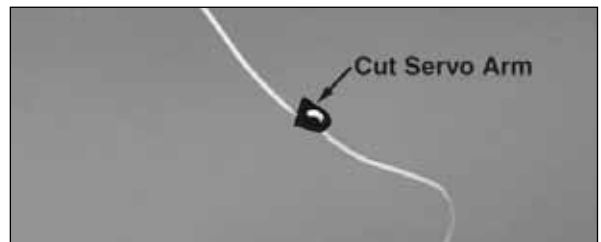

❑ 18. Make a strain relief by trimming the servo arm you cut off previously, so that only two holes remain. Thread the receiver antenna through the first hole and back through the second hole. Position the strain relief so that it is approximately 6" [152.4mm] from the receiver. The strain relief will hit the side of the fuselage, preventing the receiver antenna from being pulled loose from the receiver.



❑ 19. Drill a 3/32" [2.4mm] hole 3/4" [19mm] behind the aft edge of the wing saddle. Route the receiver antenna out the hole and tape it to the upper side of the fin. **Do not** shorten the receiver antenna. Shortening the receiver antenna will reduce the receiver's range.

Get the Model Ready to Fly

Check the Control Directions

❑ 1. Switch on the transmitter, connect the motor battery to the electronic speed control and switch on the speed control. Center the trims. If necessary, remove the servo arms from the servos and reposition them so they are centered. Reinstall the screws that hold on the servo arms.

❑ 2. With the transmitter and receiver still on, check all the control surfaces to see if they are centered. The top of the elevator should be flat with the top of the stabilizer and the rudder should be inline with the fin. If necessary, loosen the 4-40 slotted head screws in the screw-lock pushrod connectors and adjust the pushrods to center the control surfaces.

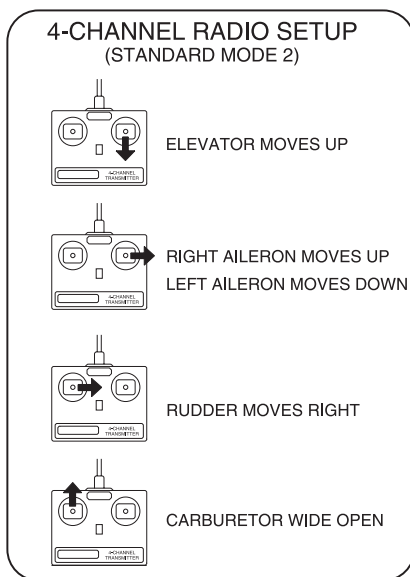

❑ 3. Make certain that the control surfaces respond in the correct direction as shown in the diagram. If any of the controls respond in the wrong direction, use the servo reversing switch in the transmitter to reverse the servos connected to those controls. Be certain the control surfaces have remained centered. Adjust if necessary. With the prop still not installed, check that the throttle lever is in the off position or low throttle. To start the motor, the start button must be pressed after the electronic speed control is switched on.

Set the Control Throws

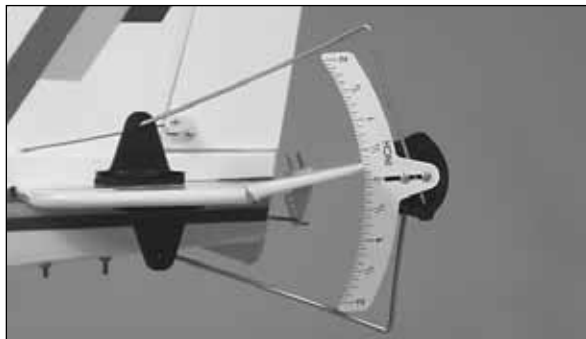

Use a Great Planes AccuThrow (or a ruler) to accurately measure and set the control throw of each control surface as indicated in the chart that follows. If your radio does not have dual rates, we recommend setting the throws at the low rate setting. **NOTE:** The throws are measured at the **widest part** of the elevator and rudder.

These are the recommended control surface throws:

	Low Rate	High Rate
Elevator:	1/4" [6.4mm] up 1/4" [6.4mm] down	7/16" [11mm] up 7/16" [11mm] down
Rudder:	3/8" [9.5mm] right 3/8" [9.5mm] left	5/8" [15.9mm] right 5/8" [15.9mm] left

IMPORTANT: The SuperStar EP has been **extensively** flown and tested to arrive at the throws at which it flies best. Flying your model at these throws will provide you with the greatest chance for successful first flights. If, after you have become accustomed to the way the SuperStar EP flies, you would like to change the throws to suit your taste, that is fine. However, too much control throw could make the model difficult to control, so remember, "more is not always better."

Install the Propeller and Motor Battery

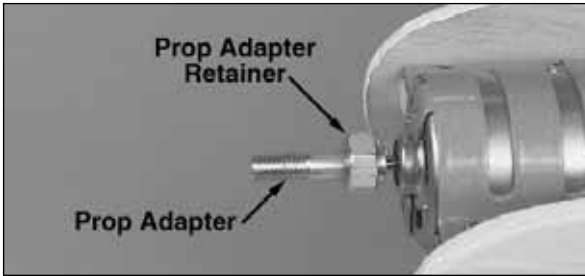

- ❑ 1. Slide the aluminum **prop adapter** over the motor shaft. Slide the aluminum **prop adapter retainer** over the prop adapter. **Note:** The hole through the prop adapter retainer is beveled. The side with the larger hole goes on first.



- ❑ 2. Slide the **propeller** onto the prop adapter. The front of the prop has 9 x 5.5 lettering molded into it. Secure the propeller to the prop adapter with the aluminum **prop washer** and **prop nut**. Hold the prop adapter retainer while tightening the prop nut. Make sure the prop is securely attached to the motor shaft.



- ❑ 3. Insert the motor battery in the battery compartment. Secure the battery with a hook and loop strap. It is not necessary to plug the motor battery into the electronic speed control until you are ready to fly.

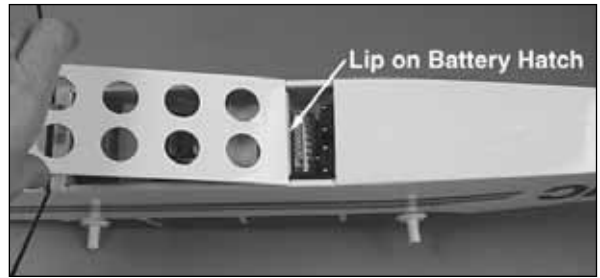

- ❑ 4. Insert the lip on the **battery hatch** under the sheeting at the aft end of the battery compartment. Lock the battery hatch in position by rotating the battery hatch retainer over the battery hatch.

Install the Wing on the Fuselage



- ❑ 1. Center the wing on the fuselage. Place a rubberband around the aft wing hold-down dowel and stretch it over the top of the wing, placing it around the forward wing hold-down dowel. Attach a second rubberband on the other side of the fuselage.



- ❑ 2. Again place a rubberband around the aft wing hold-down dowel and stretch it over the top of the wing, this time crossing over to the other side of the fuselage before placing it around the forward wing hold-down dowel.

- ❑ 3. Repeat the process to install the four remaining rubber bands.

Balance the Model (C.G.)

More than any other factor, the **C.G.** (balance point) can have the **greatest** effect on how a model flies and may determine whether or not your first flight will be successful. If you value this model and wish to enjoy it for many flights, **DO NOT OVERLOOK THIS IMPORTANT PROCEDURE.** A model that is not properly balanced will be unstable and possibly **unflyable**.

At this stage the model should be in ready-to-fly condition with all of the systems in place including the motor and prop, electronic speed control, motor battery, radio system and wing.

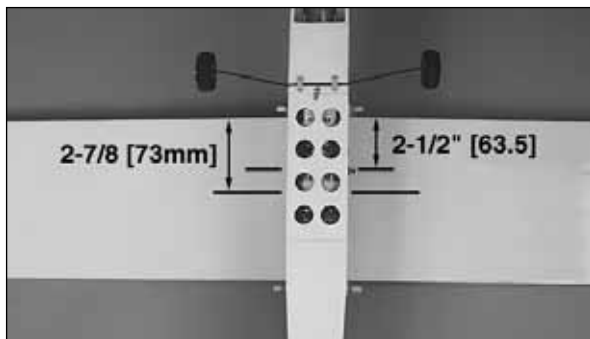

❑ 1. Use a felt-tip pen or 1/8"-wide tape to accurately mark the C.G. range on the bottom of the wing on both sides of the fuselage. **The C.G. range is located between 2-1/2" [63.5mm] and 2-7/8" [73mm] back from the leading edge of the wing.**

Your model must be balanced within this C.G. range. Balancing your model forward or aft of the C.G. range will change its flying characteristics. With the plane balanced at the forward C.G. the plane will fly smoother and be more stable, but it may require more speed for takeoff and make it more difficult to slow for landing. This is the best location for the C.G. if you are new to R/C flying. With the C.G. at the back of the C.G. range the plane will be more maneuverable, but could also become too difficult for you to control. In any case, **do not** balance your model outside the recommended range.

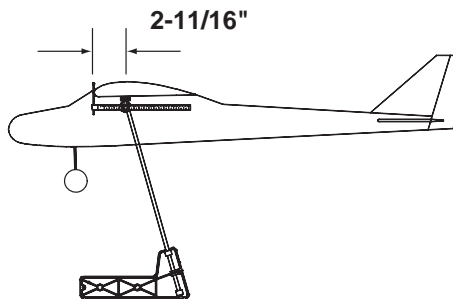

❑ 2. With the wing attached to the fuselage and all parts of the model installed (ready to fly), place the model right-side up on a Great Planes CG Machine™, or lift it right-side up within the balance range you marked.

❑ 3. Have an assistant stand 6' to 8' to the side of the model. As you lift the model, have the assistant observe the stabilizer. If the plane is properly balanced, the stabilizer will be level. If the tail drops, the model is "tail heavy" and weight must be added to the nose to balance. If the nose drops, the model is "nose heavy" and weight must be added to the tail to balance. If additional weight is required, use Great Planes (GPMQ4485) "stick-on" lead. A good place to add stick-on nose weight is beside the motor on the fuselage side. Begin by placing incrementally increasing amounts of weight on the fuse until the model balances. Once you have determined the amount of weight required, it can be permanently attached. If required, tail weight may be added to the underside of the stabilizer.

❑ 4. **IMPORTANT:** If you found it necessary to add any weight, recheck the C.G. after the weight has been installed.

Balance the Model Laterally

❑ 1. With the wing level, have an assistant help you lift the model by the motor shaft and the bottom of the fuselage, under the TE of the stabilizer. Do this several times.

❑ 2. If one wing always drops when you lift the model, it means that side is heavy. Balance the airplane by adding weight to the other wing tip. **An airplane that has been laterally balanced will track better in loops and other maneuvers.**

Proper Care of Your Motor

❑ 1. The included motor will benefit from a short “break-in” by running it **without the propeller** for at least 1/2 hour. This will seat the motor brushes on the commutator, insuring that the motor will provide full power for your first flight and extending motor life. If you notice a decrease in motor power after a number of flights, it may be due to carbon build-up on the brushes or commutator. To remove this build-up, repeat the above break-in procedure.

❑ 2. The bronze bushings in the motors are self lubricating, but their life may be extended by applying a very small amount of light machine oil to the point where the motor shaft contacts the bushings after every hour or two of run time. **Note:** A drop of oil is far too much. You should apply the oil with a toothpick. **Never oil the inside of the motor.**

❑ 3. Using multiple battery packs to run the motor for successive flights may cause the motor to become excessively hot. We recommend at least a 10 to 15 minute cool-down period between flights.

❑ 4. The ideal power source for the SuperStar EP is a 7-cell, 8.4 volt 1700 - 3000 mAh battery pack. The use of a higher voltage battery will reduce the motor life and will also require modifications to the battery compartment to allow the extra battery cells to fit.

Performance Tips

❑ 1. A new battery pack should be “cycled” for best results. You should peak charge the battery, then discharge it almost completely by actually running your motor with the propeller attached. Do this 3 or 4 times on the ground before actually flying. Be sure you remove the battery from the airplane between each cycle and allow it to cool before recharging.

❑ 2. Examine your propeller for irregularities caused by the injection molding process. Carefully remove the imperfections with fine sandpaper. Also, make sure your propeller is balanced. Vibration from the propeller will decrease the performance and life of the motor.

Preflight

Identify Your Model

No matter if you fly at an AMA sanctioned R/C club site or if you fly somewhere on your own, you should always have your name, address, telephone number and AMA number on or inside your model. It is **required** at all AMA R/C club flying sites and AMA sanctioned flying events. Fill out the identification tag on the back of this manual and place it on or inside your model.

Charge the Batteries

Follow the battery charging instructions that came with your radio control system to charge the transmitter. You should always charge your transmitter batteries the night before you go flying and at other times as recommended by the radio manufacturer.

Balance Propellers

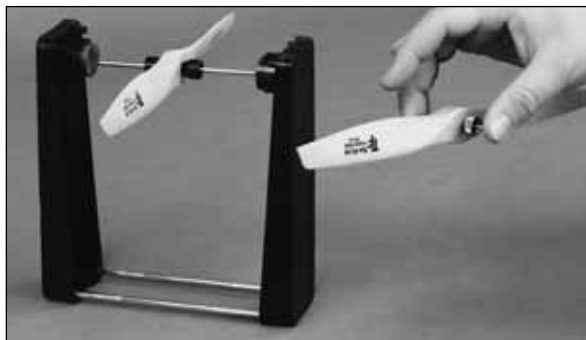

Carefully balance your propeller before you fly. An unbalanced prop can be the single most significant cause of vibration that can damage your model. Not only will mounting screws and bolts loosen, possibly with disastrous effect, but vibration may also damage your radio receiver and electronic speed control.

We use a Top Flite® Precision Magnetic Prop Balancer™ (TOPQ5700) in the workshop and keep a Great Planes® Fingertip Prop Balancer (GPMQ5000) in our flight box.

Install the propeller on the prop balancer and note which propeller blade rotates to the bottom. This is the heavy blade. To balance the prop, lightly sand the back side of the heavy blade and then recheck it on the prop balancer. This process may need to be repeated several times before the propeller is balanced.

Ground Check

After you break-in the motor on the model, inspect the model closely to make sure all screws remained tight and that the prop, pushrods and pushrod connectors are secure.

Range Check

Whenever you go to the flying field, check the operational range of the radio before the first flight of the day. First, make sure no one else is on your frequency (channel). Have an assistant hold the model, staying clear of the prop. With your transmitter on, you should be able to walk at least 100 feet away from the model and still have control. While you work the controls, have your assistant tell you what the control surfaces are doing. Repeat this test with the motor running at various speeds. If the control surfaces are not always responding correctly, do not fly! Find and correct the problem first. Look for loose servo connections or corrosion, loose bolts that may cause vibration, a defective on/off switch, low battery voltage, a damaged receiver antenna, or a receiver crystal that may have been damaged from a previous crash. If the radio appears to only be affected when the motor is running, try moving your receiver and receiver antenna farther away from the motor battery and motor. Also, installing a couple more capacitors on the motor may help. The capacitors should be soldered from the terminals to the motor case and from one terminal to the other.

AMA Safety Code (excerpts)

Read and abide by the following Academy of Model Aeronautics Official Safety Code:

General

1. I will not fly my model aircraft in sanctioned events, air shows, or model flying demonstrations until it has been proven to be airworthy by having been previously successfully flight tested.
2. I will not fly my model aircraft higher than approximately 400 feet within 3 miles of an airport without notifying the airport operator. I will give right of way to and avoid flying in the proximity of full scale aircraft. Where necessary, an observer shall be used to supervise flying to avoid having models fly in the proximity of full scale aircraft.
3. Where established, I will abide by the safety rules for the flying site I use and I will not willfully and deliberately fly my models in a careless, reckless and/or dangerous manner.

7. I will not fly my model unless it is identified with my name and address or AMA number, on or in the model.
9. I will not operate models with pyrotechnics (any device that explodes, burns, or propels a projectile of any kind).

Radio Control

1. I will have completed a successful radio equipment ground check before the first flight of a new or repaired model.
2. I will not fly my model aircraft in the presence of spectators until I become a qualified flier, unless assisted by an experienced helper.
3. I will perform my initial turn after takeoff away from the pit or spectator areas and I will not thereafter fly over pit or spectator areas, unless beyond my control.
4. I will operate my model using only radio control frequencies currently allowed by the Federal Communications Commission.

Check List

During the last few moments of preparation your mind may be elsewhere. Anticipating the excitement of the first flight. Because of this, you may be more likely to overlook certain checks and procedures that should be performed before the model is flown. To help avoid this, a checklist is provided to make sure these important areas are not overlooked. Many are covered in the instruction manual, so where appropriate, refer to the manual for complete instructions. Be sure to check the items as off they are completed.

- 1. Check the C.G. according to the measurements provided in the manual.
- 2. Be certain the motor battery and receiver are securely mounted in the fuse.
- 3. Extend your receiver antenna and make sure it has a strain relief inside the fuselage to keep tension off the solder joint inside the receiver.
- 4. Balance your model *laterally* as explained in the instructions.
- 5. Use threadlocking compound to secure critical fasteners such as the cap screws in the screw-lock pushrod connectors.
- 6. Confirm that all controls operate in the correct direction and the throws are set up according to the manual.
- 7. Make sure all servo arms are secured to the servos with the screws included with your radio.

- ❑ 8. Use an incidence meter to check the wing for twists and attempt to correct before flying.
- ❑ 9. Balance your propeller.
- ❑ 10. Check that the prop nut is tight and that the prop adapter is secure on the motor shaft.
- ❑ 11. Place your name, address, AMA number and telephone number on or inside your model.
- ❑ 12. If you wish to photograph your model, do so before your first flight.
- ❑ 13. Range check your radio when you get to the flying field.

Flying

The SuperStar EP is a great-flying model that flies smoothly and predictably. The SuperStar EP possesses the self-recovery characteristics of a primary R/C trainer. However, if you have never flown an R/C plane before, we recommend you get some help from an experienced R/C pilot for your first few flights.

CAUTION (THIS APPLIES TO ALL R/C AIRPLANES): If, while flying, you notice any unusual sounds, such as a low-pitched "buzz," this may indicate control surface *flutter*. Because flutter can quickly destroy components of your airplane, any time you detect flutter you must **immediately** cut the throttle and land the airplane! Flutter is when a control surface vibrates back and forth very quickly. This vibration can cause the control surface to come off the plane. Check all servo grommets for deterioration (this may indicate which surface fluttered) and make sure all pushrod linkages are secure and free of play. If the control surface fluttered once, it probably will flutter again under similar circumstances unless you can eliminate the free-play or flexing in the linkages. Here are some things which can cause flutter: Not mounting control horns solidly; Side-play of pushrod in guide tube caused by tight bends; Poor fit of Z-bend in control horn; Excessive *play* or *backlash* in servo gears; and Insecure servo mounting.

Takeoff

Switch on the transmitter and make sure the throttle stick is back (pulled towards you). Switch on the electronic speed control. If you have dual rates on your transmitter, set them to low. For the first flight have an assistant hand launch the plane for you. This will allow you to have both hands on the transmitter in case the plane is out of trim. To launch the SuperStar EP, grip the plane under the wing, keeping all body parts away from the propeller. Switch the motor on and toss the plane level **into the wind**. Allow the SuperStar EP to gain speed and climb out at a shallow angle before turning. The SuperStar EP can also take off from a hard surface.

Flight

Take it easy with the SuperStar EP for the first few flights, gradually getting acquainted with it as you gain confidence. Adjust the trims to maintain straight and level flight. After flying around for a few minutes and while still at a safe altitude with plenty of battery power remaining, practice slow flight and execute practice landing approaches by reducing the throttle to see how the model handles at slower speeds. Add power to see how she climbs as well. Continue to fly around, executing various maneuvers and making mental notes (or having your assistant write them down) of what trim or C.G. changes may be required to fine tune the model so it flies the way you like. Mind your battery power, but use this first flight to become familiar with your model before landing.

Landing

With electric planes it's best to land with some battery power remaining. This will allow you to abort the landing and go around again if needed. To initiate a landing approach, lower the throttle while on the downwind leg. Allow the nose of the model to pitch downward to gradually bleed off altitude. Continue to lose altitude, but maintain airspeed by keeping the nose down as you turn onto the crosswind leg. Make your final turn toward the runway (into the wind) keeping the nose down to maintain airspeed and control. Level the attitude when the model reaches the landing area, modulating the throttle as necessary to maintain your glide path and airspeed. If you are going to overshoot, smoothly advance the throttle (always ready on the right rudder to counteract torque) and climb out to make another attempt. When you're ready to make your landing flare and the model is a foot or so off the ground, smoothly increase up elevator until it gently touches down.

One final note about flying your model. Have a goal or flight plan in mind for **every** flight. This can be learning a new maneuver(s), improving a maneuver(s) you already know, or learning how the model behaves in certain conditions (such as on high or low rates). This is not necessarily to improve your skills (*though it is never a bad idea!*), but more importantly so you do not surprise yourself by impulsively attempting a maneuver and suddenly finding that you've run out of time, altitude or airspeed. Every maneuver should be deliberate, not impulsive. For example, if you're going to do a loop, check your altitude, mind the wind direction (anticipating rudder corrections that will be required to maintain heading), remember to throttle back at the top and make certain you are on the desired rates (high/low rates). A flight plan greatly reduces the chances of crashing your model just because of poor planning and impulsive moves. **Remember to think.**

**Have a ball! But always stay in control
and fly in a safe manner.**

GOOD LUCK AND GREAT FLYING!