

COMPLETE RTF AIRPLANE

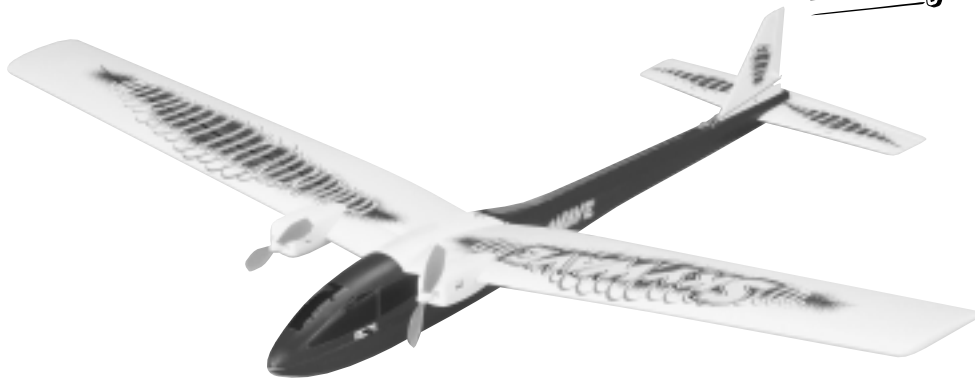

SKYWAVE™

R/C ACTION SERIES



Quiet Electric Flight

Radio-Controlled Model

Requires 8 (AA) Alkaline
Batteries (not included)

Radio-controlled!
READY-TO-FLY

ASSEMBLE ONLY WITH ADULT SUPERVISION

Please read through this instruction booklet to THOROUGHLY familiarize yourself with the assembly and flight characteristics of this airplane before beginning to assemble the kit.

Please inspect all parts carefully before starting assembly! If any parts are missing, broken or defective, or if you have any questions about the assembly or flying of this airplane, please call us at **(217) 398-8970** and we'll be glad to help.

WARRANTY

Hobbico, Inc. guarantees this kit to be free from defects in both material and workmanship at the date of purchase. This warranty does not cover any component parts damaged by use or modification. In no case shall Hobbico's liability exceed the original cost of the purchased kit. Further, Hobbico reserves the right to change or modify this warranty without notice.

In that Hobbico has no control over the final assembly, no liability shall be assumed nor accepted for any damage resulting from the use by the user of the final user-assembled product. By the act of using the user-assembled product, the user accepts all resulting liability.

If the buyers are not prepared to accept the liability associated with the use of this product, they are advised to return this kit immediately in new and unused condition to the place of purchase.

**PROTECT YOUR MODEL, YOURSELF
AND OTHERS.
FOLLOW THIS IMPORTANT SAFETY
PRECAUTION**

Your R/C Action series plane is not a toy, but rather a sophisticated, working model that functions very much like an actual airplane. Because of its realistic performance, the model, if not assembled and operated correctly, could possibly cause injury to yourself and spectators or damage property.

We highly recommend that you get experienced, knowledgeable help with assembly and during your first flights, to make your R/C modeling experience totally enjoyable. You'll learn faster and avoid risking your model before you're truly ready to solo. Your local hobby shop has information about flying clubs in your area whose membership includes qualified instructors.

You can also contact the national **Academy of Model Aeronautics** (AMA), which has more than 2,500 chartered clubs across the country. Instructor training programs and insured newcomer training are available through any one of these clubs.

Contact the AMA at the address or toll-free phone number below.

Academy of Model Aeronautics

5151 East Memorial Drive

Muncie, IN 47302

(800) 435-9262

Fax: (765) 741-0057

or via the internet at: <http://www.modelaircraft.org>

PRECAUTIONS

1. Assemble the plane **according to the instructions**. **Do not** alter or modify the model. If you make any modifications, you will void your warranty.

2. **Test** the operation of the model **before each flight** to insure that all equipment is operating properly, and that the model remains structurally sound.

3. Fly only on calm days (wind speeds less than 7mph) and in large open areas free of trees, people, buildings or any other obstacles.

Remember: Take your time and follow the instructions to end up with a well-built model that is straight, durable and easy to fly.

The R/C model hobby becomes more and more enjoyable as your experience grows. Your chances for success and graduation to higher levels are very good if you take your time and follow the assembly and flying instructions carefully and completely.

We hope you enjoy flying your R/C Action series plane.

UNPACKING THE BOX

Carefully unpack the box and lay out the parts. Check the parts against the list below. If any parts are damaged or missing, give us a call at: (217) 398-8970.

Part #	Part Name	Qty.
<input type="checkbox"/> 1.	Fuselage	1
<input type="checkbox"/> 2.	Wing	1
<input type="checkbox"/> 3.	Stabilizer	1
<input type="checkbox"/> 4.	Fin	1
<input type="checkbox"/> 5.	Motor Cover	2
<input type="checkbox"/> 6.	Propeller	2
<input type="checkbox"/> 7.	Phillips Screwdriver	1
<input type="checkbox"/> 8.	1mm x 7mm Sheet Metal Screw	5
<input type="checkbox"/> 9.	3mm x 18mm Sheet Metal Screw	1
<input type="checkbox"/> 10.	Transmitter	1
<input type="checkbox"/> 11.	NiCd Motor Battery	2
<input type="checkbox"/> 12.	Battery Charger	1
<input type="checkbox"/> 13.	Instructional Video	1

CHARGING THE NiCd BATTERY PACK

Charge the battery before assembling the airplane. You will need to use the battery to set up the radio system during assembly.

Charging the battery pack is safe and easy when you follow these instructions. Before charging, make sure that all wires and connectors are in good shape and properly insulated.

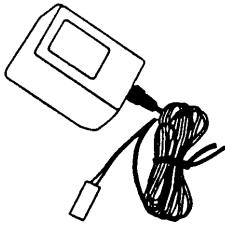

1. Connect the included battery charger to a A/C wall outlet.
2. Remove the battery pack from the box. Plug the battery into the charger connector. Be careful – the battery will plug in only one way.
3. Allow the battery to charge for 3 hours using the A/C wall charger.
4. **IMPORTANT! NEVER LEAVE A CHARGING BATTERY UNATTENDED.**
5. During charging, feel the battery to see if it is starting to warm up. A warmed up (but not hot!) battery pack is a sign that it is fully charged. Once the pack is warm, disconnect it from the charger. Depending on how much charge was already in the pack, you may have to disconnect the battery early.
6. After each flight, remove the battery from the airplane and allow it to cool completely before recharging.

SAFETY PRECAUTIONS FOR CHARGING BATTERIES

1. Never leave a charging battery unattended.
2. Never let the battery charge until it feels **hot**. A hot battery is an overcharged battery. Only let the battery get warm to the touch.
3. If you ever use a different charger, charge this battery pack only at a maximum rate of 1/2 Amp. A higher rate will charge the pack too quickly and heat up the wires.
4. A properly cared for battery pack will last a long time. If the battery pack is continually overcharged or charged at too high of a rate, the pack will not last long.

BATTERY RECYCLING

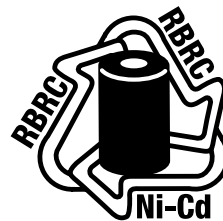

ATTENTION: The product you have purchased is powered by a rechargeable battery. The battery is rechargeable. At the end of its useful life, under various state and local laws, it may be illegal to dispose of this battery into the municipal waste system. Check with your local solid waste officials for details in your area for recycling options or proper disposal.

THE RADIO CONTROL SYSTEM

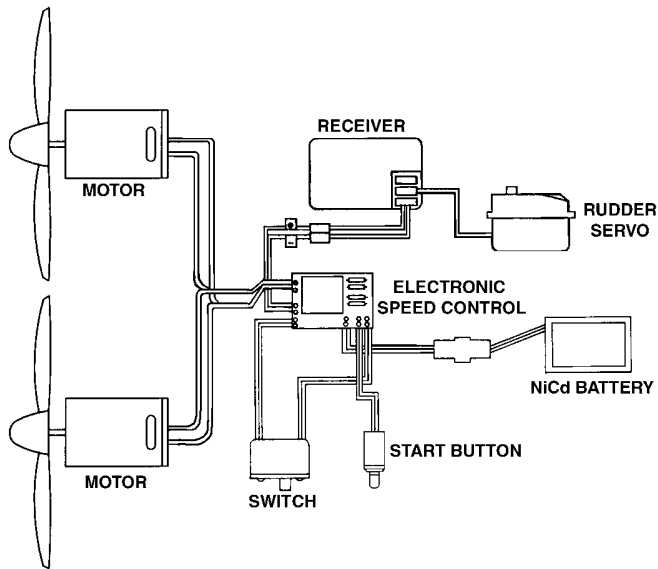

Above is a sketch detailing the layout and function of the R/C system. It is important to understand the principles of the system in order to operate your model correctly.

Charger: The device used to recharge batteries or battery packs.

Control Horn: The arm which is mounted to a control surface and attached to a pushrod.

Electronic Speed Control with Auto Cut-off: This unit controls the speed of the motor. Also it monitors the battery voltage and turns off the motor so that there will be enough battery power to operate the radio while you glide and land the airplane. A fully charged battery will allow the motor to run about 2-3 minutes before turning off.

Motor: The motors rotate the props to provide thrust.

NiCd Battery: Rechargeable batteries which are used as power for the airplane.

Receiver (RX): The radio unit in the airplane which receives the transmitter signal and relays the control to the servos.

Servos: The electronic/mechanical device which moves the control surfaces of the airplane according to the commands of the transmitter/receiver.

Switch: Turns on the power to the receiver, servos and motor.

Start Button: With the switch on, pressing the start button arms the motor. To turn the motors on, move the throttle stick forward (away from you). To turn the motors off, move the throttle stick back (toward you).

Transmitter (Tx): This is the hand-held unit that sends the signal to the receiver. As you move the stick on the transmitter, the servo in the airplane will react accordingly.

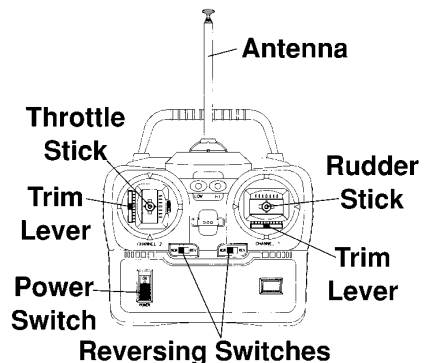

INSTALLING THE MAIN WING



- ❑ At the front edge of the wing you will notice a small plastic post. To install the wing, push the post into the hole on the fuselage. Fasten the wing to the fuselage with the 3mm x 18mm sheet metal screw (the largest screw).

TEST FIT THE MOTOR COVERS

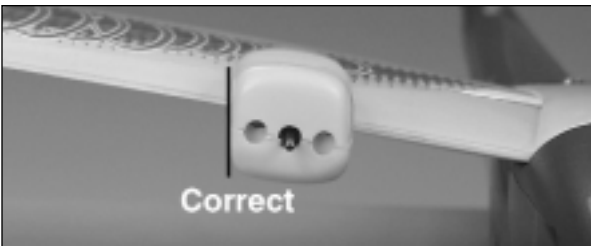
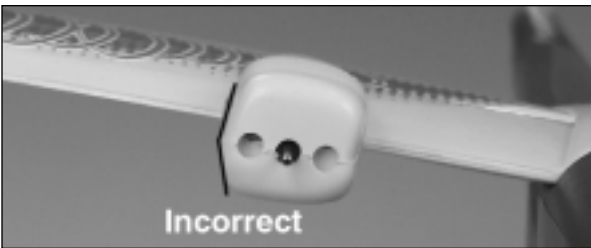

- ❑ There is a left and a right motor cover. Test fit one of the motor covers over one of the motors. If it is the correct one,

the motor cover assembly will look symmetrical. If it is the wrong one, fit the motor cover on the other motor.

INSTALLING THE MOTOR COVERS



- ❑ Turn the airplane upside-down and secure the motor covers to the wing using 1mm x 7mm sheet metal screws.

INSTALLING THE HORIZONTAL STABILIZER

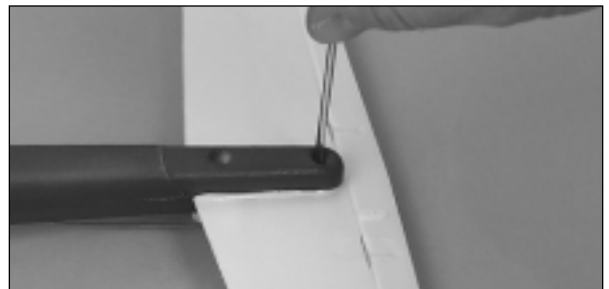

- ❑ Gently work the control horn on the horizontal stabilizer onto the Z-bend. Turn the plane upside-down. Position the stabilizer on the fuselage. Fasten the tail piece to the fuselage with two 1mm x 7mm sheet metal screws (small screws).

INSTALLING THE VERTICAL STABILIZER

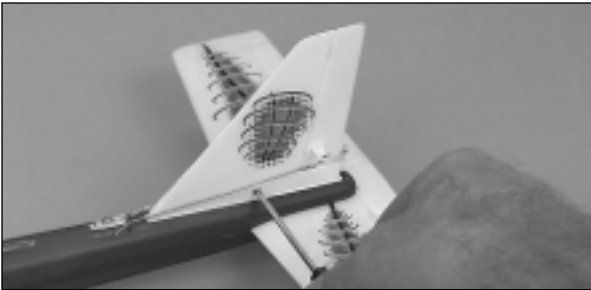
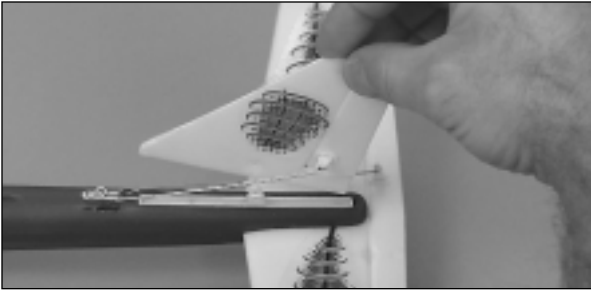

❑ Turn the plane right-side up, push the Z-bend through the outermost hole in the vertical stabilizer. Then, insert the vertical stabilizer in the slot, and gently move it back and forth until the screw holes on the vertical stabilizer and brace line up. Secure the vertical stabilizer to the fuselage with a 1mm x 7mm sheet metal screw.

INSTALLING THE PROPELLERS

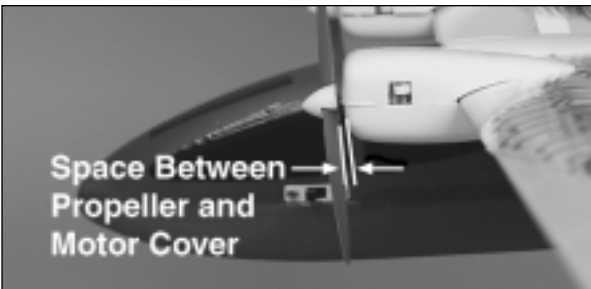

❑ Press the propellers onto the motor shafts. Be sure to leave a space between the propeller and the front of the motor cover.

INSTALLING THE TRANSMITTER BATTERIES



❑ The transmitter that controls your airplane requires power, in the form of eight "AA" batteries. To install the batteries, just turn over the transmitter, remove the battery hatch and install the batteries. Reinstall the battery hatch and check the LEDs on the front of the transmitter. Like traffic lights, green means "GO!" However, if the red LED is glowing, you need to install fresh batteries.

TRANSMITTER SET UP



❑ This is also a good time to make sure that your radio's servo reversing switches are correctly set. Both the switch for the throttle servo and the rudder servo should be on "NOR" (normal) setting.

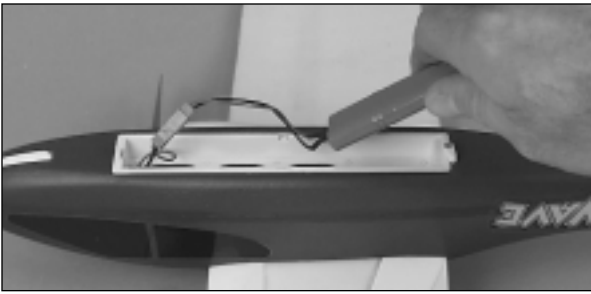

❑ After the NiCd battery is charged, install it in the plane. Remove the battery hatch and simply attach the battery to the connector inside your plane. This battery will provide power to all the electronics in your plane.

HOW DOES THE AIRPLANE WORK?

Your transmitter controls the airspeed and direction. You can go as slow or as fast as you want, but remember: the faster you fly, the faster your battery power is used up.

When battery power gets too low, the "Auto Cut-Off" feature of the speed control provides an extra degree of insurance. It reacts to low power by cutting power to the motor, in effect saving power for the receiver. That way, your airplane goes into a glide and you stay in control until you land.

CHOOSE A GOOD FLYING SITE

It's best to fly on calm days, when there's little or no wind. Also, find an area clear of trees, power lines and other structures. A park or schoolyard is good, if not crowded; a flying field for R/C airplanes is best. Don't fly around groups of people, especially children. The moving prop can be dangerous.

CHECK YOUR PLANE FOR LEVEL FLIGHT

It's easy to do. With the motor off, hold your airplane by the fuselage and gently toss it straight out into the wind. It should fly straight and level before floating gently to the ground.

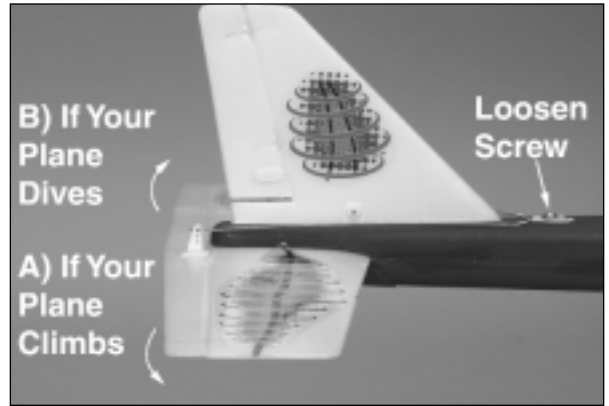

If your plane doesn't fly level, you'll need to adjust the elevator. This is the movable part of the horizontal stabilizer. To adjust the elevator, simply loosen the screw that holds the control wire, make a small adjustment up or down, re-tighten and test it again.

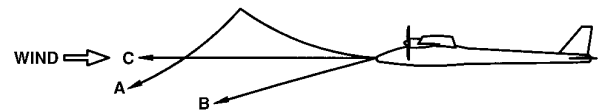

A. If your plane climbs and stops in mid-air before gliding to the ground...

You need to adjust the elevator slightly downward.

B. If your plane dives when you launch it...

You need to adjust the elevator slightly upward.

C. If your plane flies level then slowly glides to the ground...

Your airplane is ready to fly.

It may take several tries to make your plane fly level. The best way to do it is to make very small adjustments to the elevator (1/16" or less), and then test the effect of the change.

CHECK THE SPINNER AND PROPELLERS

After test gliding the airplane, make sure the spinners do not rub against the motor covers. You will need to check them after every flight.

PREPARE FOR TAKEOFF

1. Find an open area free of buildings, trees, power lines and people.
2. For your first few flights, fly only in winds of no more than 3 miles per hour. After you are comfortable with the

airplane, you can fly in winds that are no more than 7 miles per hour. If flown in stronger winds, the plane may be blown down wind and not have enough power to get back to you.

3. Make sure the NiCd battery is fully charged and that the transmitter has good "AA" batteries installed.

4. If others are flying in the same area, make sure that they are not using the same channel radio system you are. The front of your transmitter has a tag with a color and number (for example 27.145). This is the frequency you are using.

5. Range check your radio before each flight. Switch on the transmitter and then the receiver. **Do not push the motor start button during the radio range check.** With the antenna collapsed, walk 50 feet away from the airplane. Move the rudder control stick checking that the rudder moves. If you still have control over the airplane, it is safe to extend the antenna and fly the airplane.

FLYING THE AIRPLANE

1. First, turn your transmitter power switch "ON." This immediately puts you in control. Be sure your throttle stick is back (pulled all the way towards you).

2. Now pick up the airplane and switch the airplane on.

3. Press the start button. **Caution: keep your hands behind the props.**

4. Move the throttle stick forward (moved away from you). The propellers will start to turn. The farther you move the stick, the faster the propellers will turn.

5. With the throttle stick moved fully forward (full throttle), hand launch your airplane into the wind, at a slight upward angle.

6. Allow the airplane to climb a few seconds before turning it.

7. The right stick is your rudder control. When your plane is moving away from you, moving the rudder stick to the left will make your plane turn to the left. Moving the rudder stick to the right will make your plane turn right.

8. When the plane is coming toward you, moving the rudder stick left still causes left rudder, but your plane goes to **your** right. In short, you have to reverse the way you control the rudder. A good way to familiarize yourself with the controls is when the plane is coming toward you, turn your body so that you are facing the same direction the plane is going, looking over your shoulder at the plane. Now when you move the rudder stick left the plane will go left.

9. When turning, the plane will lose some altitude. The sharper the plane turns, the more altitude it will lose. Try to make gentle turns.

10. Don't let the airplane get too far away from you. The farther away it is, the harder it is to see what the plane is doing.

LANDING

Once the motors cuts off, prepare to land. Always land as straight into the wind as possible. You may need to circle the plane a few times to gradually descend to the ground.

AFTER THE FLIGHT

Switch the airplane then the transmitter off. Unplug and remove the NiCd battery. Allow the NiCd battery to cool before recharging. Check the plane making sure nothing has come loose.

STRUCTURE

In the unfortunate event that you may damage your airplane, repairs are fairly simple to make yourself. If there are any cracks in the wing or fuselage, apply 6-minute epoxy to the broken area and hold together with clear packaging tape. Let the glue cure, leaving the tape in place for added strength.

After all repairs are completed, check that the props are not hitting the motor covers or are damaged.

We hope this short instruction manual and the included video on flying helps you get off to a great start in R/C flying.

PARTS LIST

Replacement parts for your SkyWave

SkyWave Parts

Stock

HCAA3220
HCAA3221
HCAA3222
HCAA3224
HCAA3225
HCAM7025
HCAG1010
HCAM7026
HCAQ3010

Description

Main Wing Set
Complete Tail Set
Fuselage
Decal Set
Wing Mount Set & Motor Covers
Battery
Motor
Electronic Speed Control
Propeller