

COMPLETE RTF AIRPLANE

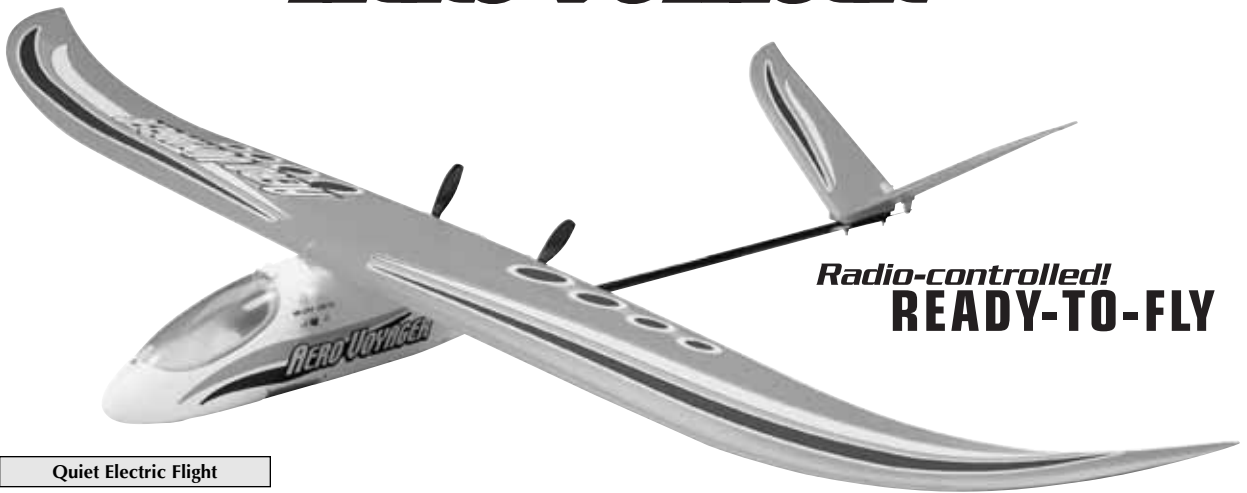

AERO VOYAGER™



Radio-controlled!
READY-TO-FLY

Quiet Electric Flight

Radio-Controlled Model

Requires 8 (AA) Alkaline
Batteries (not included)

ASSEMBLE ONLY WITH ADULT SUPERVISION

Please read through this instruction booklet to **THOROUGHLY** familiarize yourself with the assembly and flight characteristics of this airplane before beginning to assemble the kit.

Please inspect all parts carefully before starting assembly! If any parts are missing, broken or defective, or if you have any questions about the assembly or flying of this airplane, please call us at **(217) 398-8970** and we'll be glad to help.

WARRANTY

Hobbico® guarantees this kit to be free from defects in both material and workmanship at the date of purchase. This warranty does not cover any component parts damaged by use or modification. **In no case shall Hobbico's liability exceed the original cost of the purchased kit.** Further, Hobbico reserves the right to change or modify this warranty without notice.

In that Hobbico has no control over the final assembly, no liability shall be assumed nor accepted for any damage resulting from the use by the user of the final user-assembled product. By the act of using the user-assembled product, the user accepts all resulting liability.

If the buyers are not prepared to accept the liability associated with the use of this product, they are advised to return this kit immediately in new and unused condition to the place of purchase.

To make a warranty claim send the defective part or item to Hobby Services at the address below:

Hobby Services
3002 N. Apollo Dr., Suite 1
Champaign IL 61822 USA

Include a letter stating your name, return shipping address, as much contact information as possible (daytime telephone number, fax number, e-mail address), a detailed description of the problem and a photocopy of the purchase receipt. Upon receipt of the package the problem will be evaluated as quickly as possible.

PROTECT YOUR MODEL, YOURSELF AND OTHERS. FOLLOW THIS IMPORTANT SAFETY PRECAUTION

Your Aero Voyager plane is not a toy, but rather a sophisticated, working model that functions very much like an actual airplane. Because of its realistic performance, the model, if not assembled and operated correctly, could possibly cause injury to yourself and spectators or damage property.

We highly recommend that you get experienced, knowledgeable help with assembly and during your first flights, to make your R/C modeling experience totally enjoyable. You'll learn faster and avoid risking your model before you're truly ready to solo. Your local hobby shop has information about flying clubs in your area whose membership includes qualified instructors. You can also contact the national **Academy of Model Aeronautics (AMA)**, which has more than 2,500 chartered clubs across the country. Instructor training programs and insured newcomer training are available through any one of these clubs.

Contact the AMA at the address or toll-free phone number below.

Academy of Model Aeronautics

5151 East Memorial Drive

Muncie, IN 47302

(800) 435-9262

Fax: (765) 741-0057

or via the Internet at: <http://www.modelaircraft.org>

PRECAUTIONS

1. Assemble the plane **according to the instructions**. Do **not** alter or modify the model. If you make any modifications, you will void your warranty.
2. **Test** the operation of the model **before each flight** to insure that all equipment is operating properly, and that the model remains structurally sound.
3. Fly only on calm days (with wind speeds less than 5 mph) and in large open areas free of trees, people, buildings or any other obstacles.

Remember: Take your time and follow the instructions to end up with a well-built model that is durable and easy to fly.

The R/C model hobby becomes more and more enjoyable as your experience grows. Your chances for success and graduation to higher levels are very good if you take your time and follow the assembly and flying instructions carefully and completely. We hope you enjoy flying your Aero Voyager plane.

GLOSSARY

Electronic Speed Control/Receiver (ESC/RX): This unit controls the motors and control surfaces.

Ruddervator (V-Tail): Controls altitude and direction.

Motors: The motors rotate the props to provide thrust.

Nickel-Metal Hydride (NiMH) Battery: Rechargeable batteries which are used to power the airplane. NiMH batteries are lighter and smaller than most other types of rechargeable batteries.

Transmitter (TX): This is the hand-held unit that sends the signal to the control unit. Moving the stick controls the direction and climb/decent. The throttle lever controls the motors.

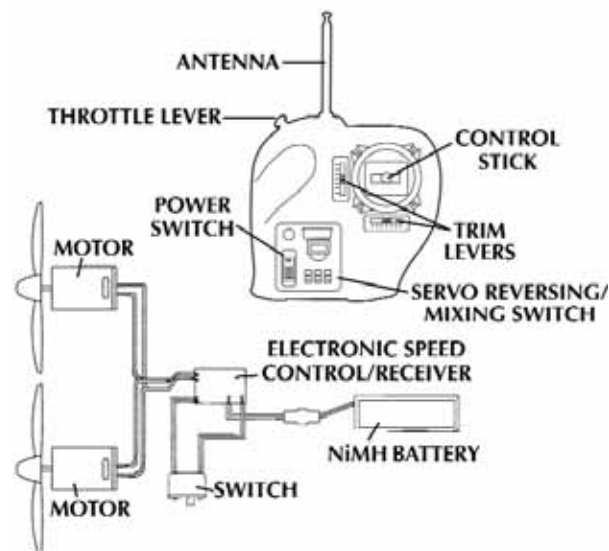

AIRFRAME PARTS AND HARDWARE

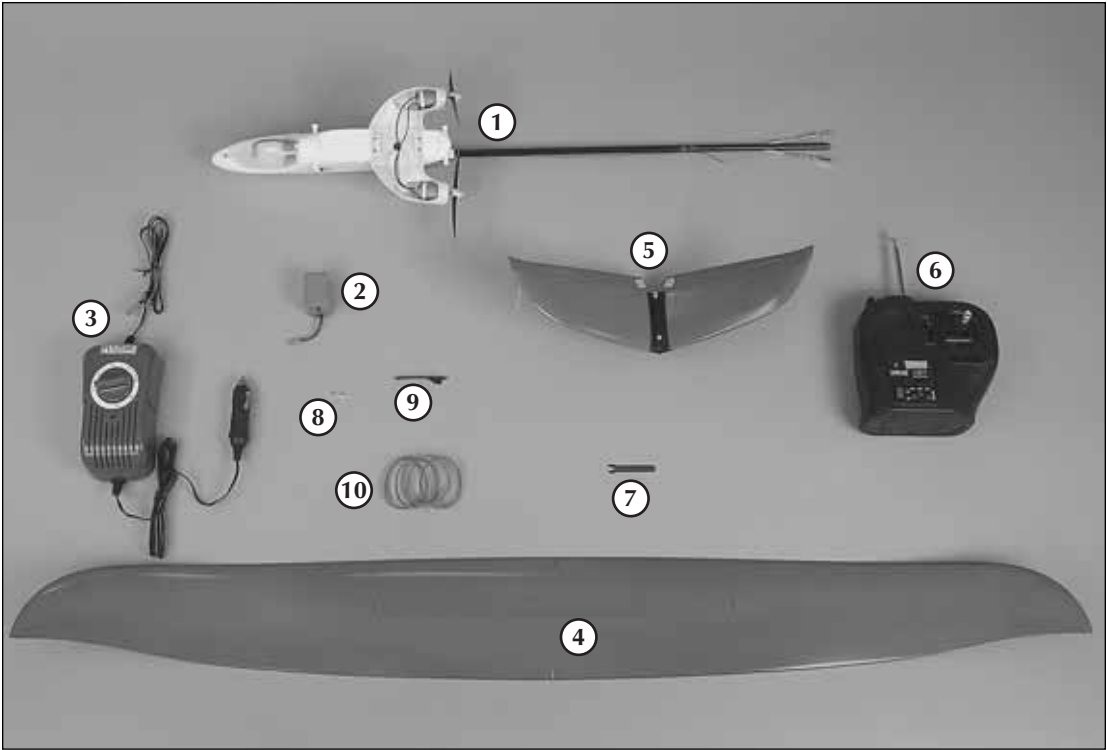

UNPACKING THE BOX

Check the parts against the list below.

If any parts are damaged or missing, give us a call at: (217) 398-8970.

	Part Name	Qty.
<input type="checkbox"/>	1. Fuselage/Tail Boom	1
<input type="checkbox"/>	2. 600 mAh NiMH Battery	1
<input type="checkbox"/>	3. Charger	1
<input type="checkbox"/>	4. Wing	1
<input type="checkbox"/>	5. V-Tail	1
<input type="checkbox"/>	6. Transmitter	1
<input type="checkbox"/>	7. Wrench for Tightening Nuts	1
<input type="checkbox"/>	8. Nuts	2
<input type="checkbox"/>	9. Tail Skid	1
<input type="checkbox"/>	10. Rubber Bands.....	4
<input type="checkbox"/>	Spare Propellers (Not Shown in Photo)	2
<input type="checkbox"/>	Decal (Not Shown in Photo)	1
<input type="checkbox"/>	Instructional DVD (Not Shown in Photo)	1

INSTALL THE V-TAIL

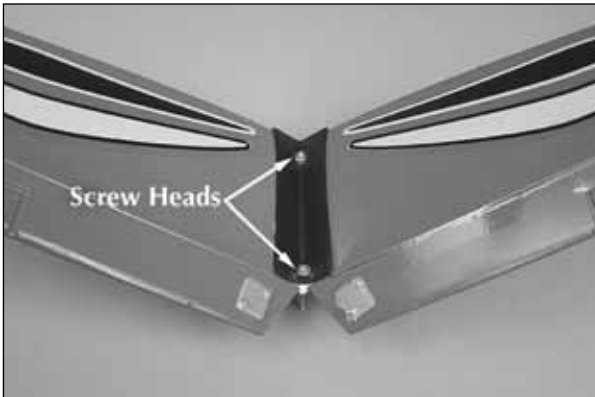

1. Apply the decals to the top of the airplane surfaces as seen on the box. (The top of the V-tail has the two screw heads showing.)

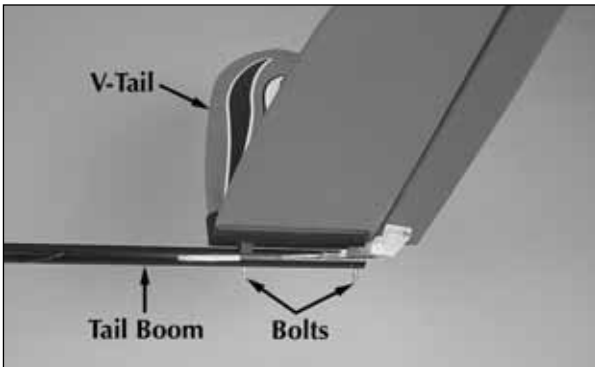

2. Insert the mounting bolts of the V-tail through the holes from the top of the tail boom as shown in the photo.

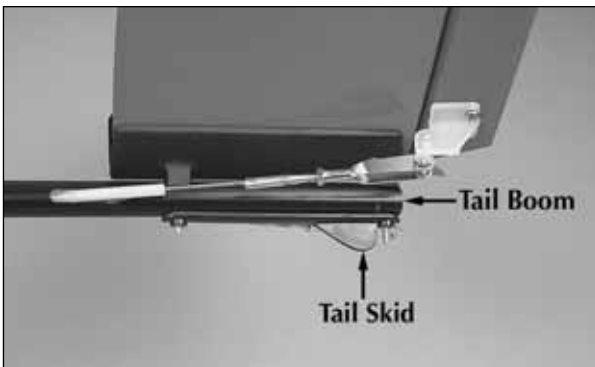

3. Install the tail skid over the mounting bolts. Make sure the tail skid is pointing down and to the rear of the airplane.

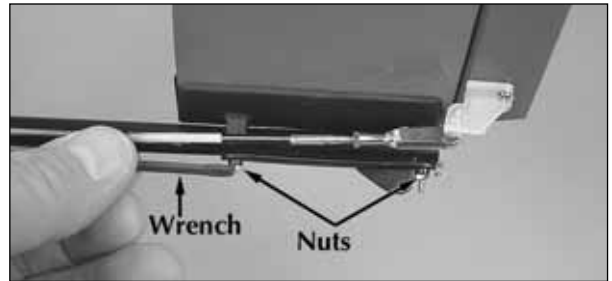

4. Place the two nuts on the mounting bolts that extend through the bottom of the tail boom as shown in the photo. Using the included wrench, tighten the nuts firmly but do not overtighten. You have now completed the assembly of the V-tail.

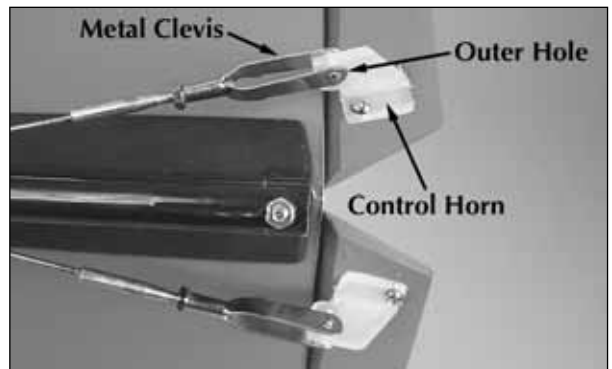

5. Spread the metal clevises apart and insert the clevis pin in the outer hole of the control horns. Make sure the clevis snaps closed over the control horn.

INSTALL THE WING



1. Position the wing, centered on the fuselage. The two indentations on the top of the wing should be aligned with the center of the fuselage. Secure the wing with two rubberbands.

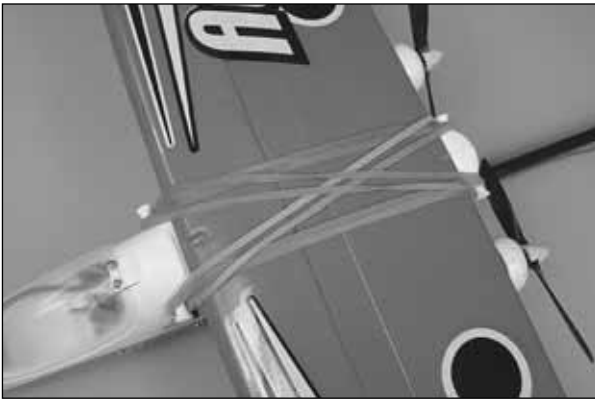

- ❑ 2. Attach two additional rubberbands, crossing them over the top of the wing.

PREPARE THE TRANSMITTER

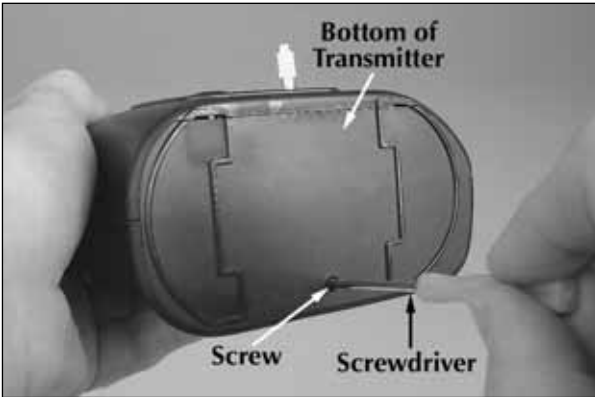

- ❑ 1. The transmitter that controls your airplane requires power, in the form of eight "AA" batteries. To install the batteries loosen the screw on the bottom of the transmitter and remove the battery hatch.

- ❑ 2. Pull the battery holder out of the transmitter case and install eight new "AA" batteries in the holder following the diagram on the holder.

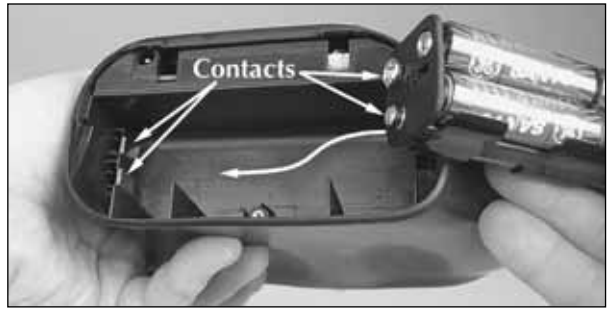

- ❑ 3. Insert the battery holder in the transmitter case so that the two contacts on the battery holder align with the contacts in the transmitter case. Reinstall the battery hatch on the transmitter case and tighten the screw.



- ❑ 4. Switch on the transmitter and check the LED on the front of the transmitter. If the green light is on, it is safe to fly. If the red light is on or flashing, you need to install fresh batteries.

- ❑ 5. On the front of the transmitter are three switches. The two switches on the left are for reversing the direction of the servos. The mixing switch on the right turns the V-tail mixing on or off. Set ch.1 switch to **NOR**, ch.2 to **REV** and mix to **ON**.



Caution:

- Do not use rechargeable (NiCd) batteries.
- Do not mix old and new batteries.
- Do not mix alkaline, standard (carbon-zinc) or rechargeable (NiCd) batteries.

CHARGE THE PLANE'S NIMH BATTERY



1. Plug the battery charger into a 12-volt power outlet in a vehicle, placing the charger and battery outside the car, away from flammables.



2. Plug the battery pack into the charger connector. Be careful - the battery pack will plug in only one way.



3. Rotate the timer knob on the charger to **30 minutes**. Make sure the red light comes on.

4. **IMPORTANT! NEVER LEAVE A CHARGING BATTERY UNATTENDED.**

5. During charging, feel the battery every 5 minutes to see if it is starting to warm up. A warmed up (but not hot) battery pack is a sign that it is fully charged. Once the pack is warm, disconnect it from the charger. Depending on how much charge was already in the pack, you may have to disconnect the battery early.

6. Always disconnect the charger from the 12-volt power outlet in your vehicle when finished charging.

7. After each flight, completely discharge the battery and remove the battery pack from the airplane and allow it to cool completely before recharging. To fully discharge your airplane battery, run the motors at high speed until they stop.

BATTERY CHARGING PRECAUTIONS

1. Be careful to avoid overcharging the battery! When you plug the battery into the charger there is no way to know how much charge is left in the battery (unless you have just completed a flight in which the battery was run all the way down or have fully discharged the battery). If you put too much charge into the battery, it will get very hot. This may result in melting the plastic battery cover, causing the cells to vent and damaging the charger! Always remove the battery from your Aero Voyager before charging.

2. Remember to check the temperature of the battery every 5 minutes during the charge. Unplug the battery as soon as it warms up (before it gets hot), even if the timer has not yet run down.

3. Charging the Aero Voyager battery while your car's engine is running can be dangerous, because it increases the chances of overcharging. For this reason, you should **never** charge your Aero Voyager battery while your car's engine is running.

4. If your battery is not completely discharged before charging, the charging time may take less than 30 minutes. Again, only let the battery get warm to the touch – not hot.

5. If you use a different battery charger, charge this battery pack only at a maximum charge rate of 1/2 amp. A higher charge rate will charge the battery pack too quickly and heat up the wires.

❑ 6. A properly cared for battery pack will last a long time. If the battery pack is continually overcharged or charged at too high of a rate, the life of the battery pack will be shortened.

WARNING: Misuse or malfunction may overheat the battery and charger, resulting in personal injury or damage to surroundings.

BATTERY RECYCLING



ATTENTION: The product you have purchased is powered by a rechargeable battery. At the end of the battery's useful life, under various state and local laws, it may be illegal to dispose of this battery into the municipal waste system. Check with your local solid waste officials for details in your area for recycling options or proper disposal.

WARNING: This product contains a chemical known to the State of California to cause cancer.

CHECK THE BALANCE OF YOUR MODEL

Note: This section is **VERY** important and must **NOT** be omitted! A model that is not properly balanced will be unstable and possibly unflyable.



❑ 1. After the battery pack is charged, open the battery hatch canopy. Insert the battery pack inside the fuselage. Do not plug the battery pack into the connector inside the fuselage. Close the canopy.

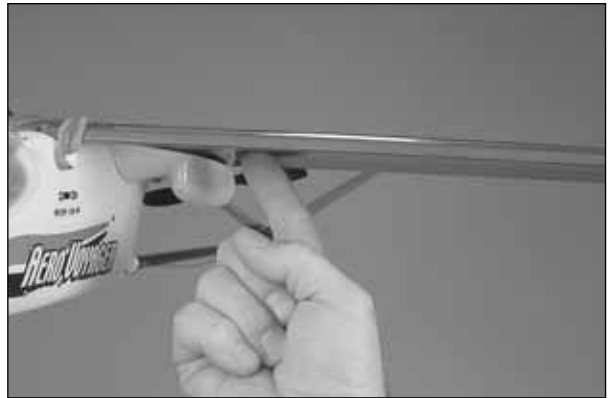
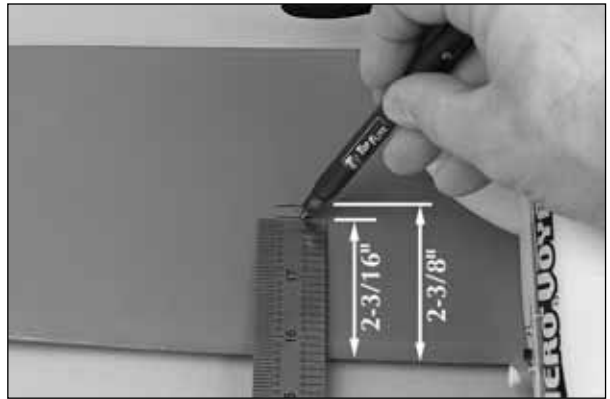

❑ 2. Place marks on the bottom of the wing 2-3/16" [56mm] and 2-3/8" [60mm] back from the front of the wing, next to the left and right sides of the fuselage. Turn the airplane right side up. Try balancing the airplane on your finger tips, between these marks. This is where the model should balance. We also found that most of our test models balanced at this point without having to add weight to the nose or tail. If it does not balance at these marks, weight will need to be added to the nose or tail. At most hobby shops, you can purchase stick-on lead weight made specifically for balancing airplanes.

HOW DOES THE AERO VOYAGER WORK?

Your transmitter controls the altitude, direction and speed of the plane. The right stick controls the altitude and direction and the lever on the top of the transmitter controls the speed.

❑ 1. First switch on the transmitter and make sure the green light is on.



❑ 2. Open the battery canopy and plug the battery pack into the plug in the fuselage.

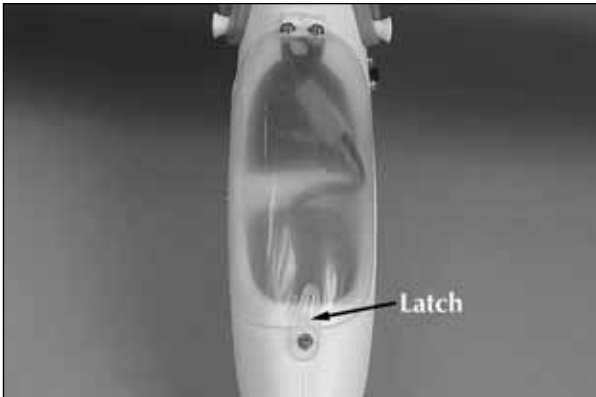

❑ 3. Close and latch the canopy.



❑ 4. Move the power switch back to the "ON" position.

CAUTION: Stay clear of the propellers once the battery pack is plugged in and the switch is turned on.

CHECK THE CONTROLS



❑ 1. Center the trim levers on the front of the transmitter.

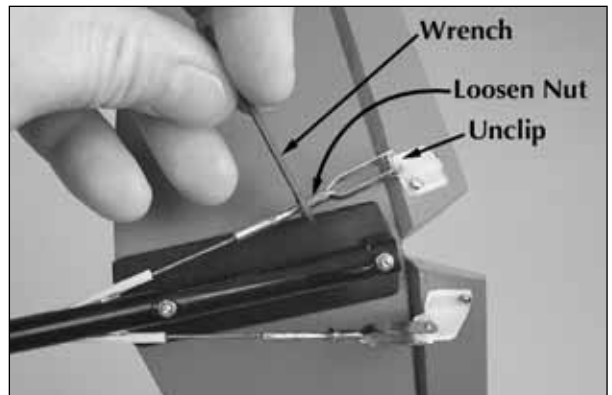
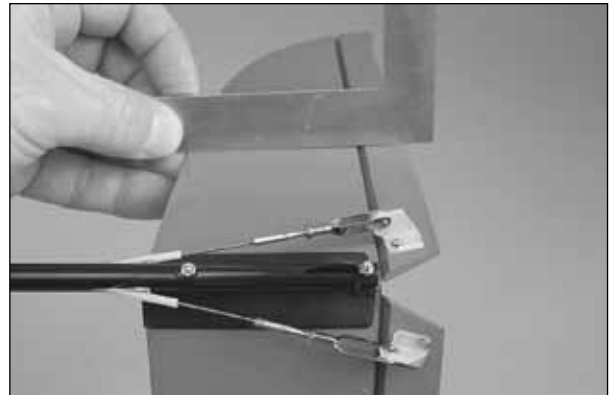

❑ 2. Place a straightedge across the bottom of the V-tail. It should be flat all the way across. If it is not, unclip the clevis from the control horn and use the included wrench to loosen the nut securing the clevis. Now the clevis can be rotated in or out. Reattach the clevis to the control horn and

check the V-tail again. This adjustment may require several adjustments before it is correct. Tighten the nut against the clevis with the wrench. Do not overtighten.

❑ 3. Check both the left and right side of the V-tail. **NOTE:** If the V-tail cannot be adjusted correctly by rotating the clevises, see page 11 for details on adjusting the servos.

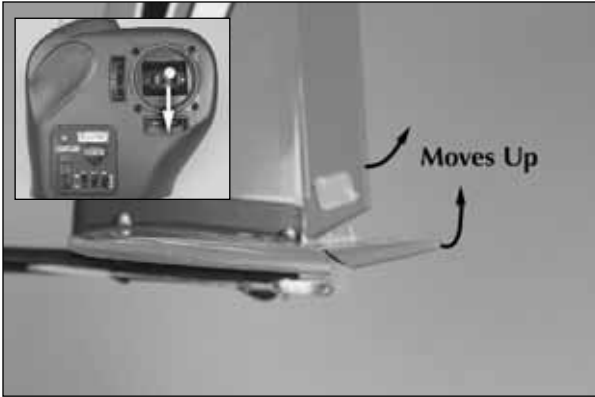

❑ 4. Hold the Aero Voyager while you move the right stick on the transmitter back. The control surfaces on the V-tail should both move up. This will cause the plane to climb.

❑ 5. Moving the right stick forward will cause the control surfaces to move down. This will cause the plane to descend.

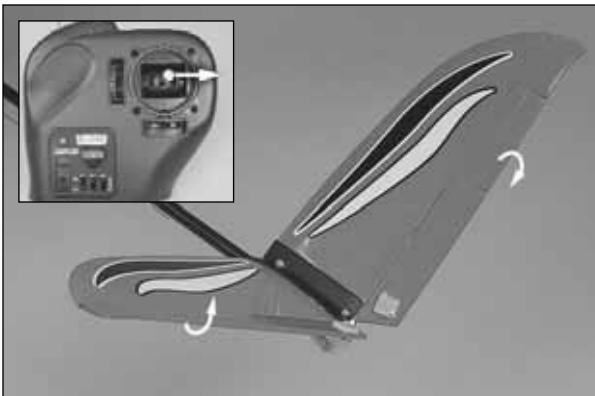

❑ 6. Move the right stick on the transmitter to the right. The left control surface will go up and the right control surface will go down. The plane will turn to the right.

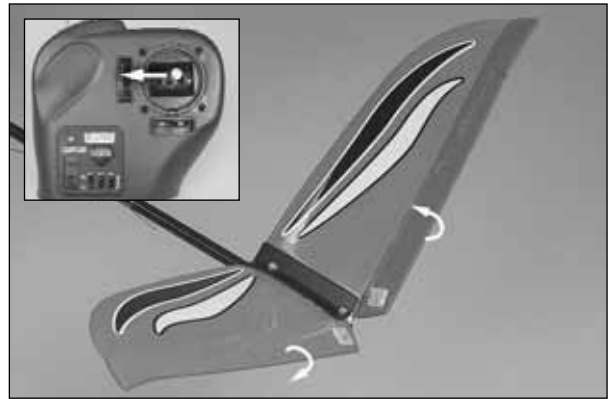

❑ 7. Move the right stick on the transmitter to the left. The left control surface will go down and the right control surface will go up. The plane will turn to the left.



❑ 8. To start the motors, the throttle lever must first be “OFF”, all the way to the left when switching on the transmitter and plane. Then move the lever all the way to the right and hold it there for 5 seconds. Then return the lever to the left. This will “arm” the motors. The motors will now operate when the throttle lever is moved to the right. **NOTE:** Arming the motors will need to be done each time after the transmitter has been turned OFF!

CHOOSE A GOOD FLYING SITE

The Aero Voyager should be flown only when the wind speed is 5 mph or less. If the wind is calm or very light, the Aero Voyager will be docile and easy to control. Also, find an area clear of trees, power lines and other structures. A flying field for R/C planes is best. Don't fly around groups of people, especially children or within 6 miles of existing R/C flying fields.

PREPARE FOR TAKEOFF

1. Find an open area free of buildings, trees, power lines and people.
2. For your first few flights, fly only when the wind is calm. After you are comfortable with the airplane, you can fly in winds that are no more than 5 miles per hour. If flown in stronger winds, the plane may be blown down wind and not have enough power to get back to you.
3. Make sure the battery pack is fully charged and that the transmitter has fresh "AA" batteries installed.
4. If others are flying in the same area, make sure that they are not using the same channel radio system you are. The front of your transmitter has a tag with a number on it (i.e. 1 through 6 and 26.995 through 27.255). This is the channel number and frequency you are using. If someone is on the same channel or frequency, **DO NOT** switch on your transmitter until they are finished flying.
5. Range check your radio before each flight. Switch on the transmitter and then switch on the airplane. Have a helper hold the airplane. With the antenna collapsed, walk 100 feet away from the airplane. Move the control stick, checking that the control surfaces respond. Also turn the motors on and check the range. If you still have control over the airplane, it is safe to extend the antenna and fly the airplane. If you do not have control of the plane, make sure the batteries in the transmitter are fresh and the battery in the plane is charged. Also, make sure the wire antenna is extending out the back of the plane.

FLYING THE AERO VOYAGER

1. Have an assistant help with the launch. Arm the motors by moving the throttle lever to the right for 5-seconds then back to the left. Start the motors by moving the throttle lever to the right. Have your assistant launch the plane into the wind. It is not necessary to throw the plane really hard. Just a nice, smooth and level toss into the wind is more than enough.
2. Move the right stick toward you so that the plane climbs at a 20 to 30 degree angle. Allow the plane to gain some altitude and air speed before turning.

3. To turn the Aero Voyager, move the right stick to the left or right slightly. The more you move the stick, the tighter the turn will be. To stop the turn, move the stick the opposite direction until the plane is flying straight. You may need to add a little up elevator (move the stick back toward you) to maintain level flight in the turn.
4. When the plane is coming toward you, moving the right stick left still causes the plane to turn left, but it appears to turn to the right. In short, you have to reverse the way you control the right stick. A good way to familiarize yourself with the controls is when the plane is coming toward you, turn your body so that you are facing the same direction the plane is going, looking over your shoulder at the plane. Now when you move the right stick left the plane will go to the left.
5. Don't let the airplane get too far away from you. The farther away it is, the harder it is to see what the plane is doing.
6. When learning to fly, it is best to keep the plane high enough so that if you make a mistake, you have enough altitude to correct the mistake.

IT'S NOW TIME TO LAND

It's a known fact among fellow R/C pilots that your airplane will land. It is up to you as to where and how it lands.

1. For your first couple of flights we recommend that you attempt to land before the motors stop. Your Aero Voyager comes with an auto cut-off feature which reserves battery power for safe landings.
2. During your first flight, while at a high altitude, turn the motors off and notice how the Aero Voyager reacts. This will give you an idea of how the plane will react during landing.
3. To land the Aero Voyager, fly down wind, past the landing area a few yards. Gently turn into the wind and turn the motors off. The plane will start to come down. If it appears that the Aero Voyager will be short of the landing area, turn the motors back on for a couple of seconds to lengthen your approach.
4. As the Aero Voyager slowly descends, use the right stick to control the direction. The Aero Voyager will just about land itself. All you need to do is control its direction.

AFTER THE FLIGHT

Switch off the airplane. Then, switch the transmitter off. Unplug the battery from the plane and remove it from the battery compartment. Allow the motors and battery to cool before recharging. Check the plane over to make sure nothing has come loose or may be damaged.

REPLACEMENT PARTS LIST

To order replacement parts for your Aero Voyager, use the order numbers in the list below. Replacement parts are available only as listed. Replacement parts are not available from Product Support, but can be purchased from hobby shops or mail order/Internet order firms. If you need assistance locating a dealer to purchase parts, contact:

Product Support
Phone: 217-398-0007
Fax: 217-398-7721
E-mail: productsupport@hobbico.com

Before starting to build, take an inventory of this kit to make sure it is complete and inspect the parts to make sure they are of acceptable quality. If any parts are missing or are not of acceptable quality, or if you need assistance with assembly, contact Product Support. When reporting defective or missing parts, use the part names exactly as they are written in the parts list.

Stock #	Description
HCAA3413	Main Wing Kit
HCAA3414	Tail Assembly Kit
HCAA3415	Decals
HCAA3416	Fuse Set w/Pushrods
HCAA3417	Servo Hatch Door
HCAA3507	Canopy (Hatch)
HCAA3510	Motor Pod
HCAG1012	Motors (2)
HCAM7024	Battery NiMH
HCAM7106	TX Antenna
HCAP9918	12V Field Charger
HCAQ3303	Propellers (4)

REPAIRS

Even the best R/C pilots in the world damage their planes every now and then. In the unfortunate event that you damage your airplane, repairs are fairly simple to make yourself. If there are any cracks in the wing or fuselage, apply 6-minute epoxy or white glue to the broken area and hold together with clear packaging tape. Let the glue cure, leaving the tape in place for added strength.

SERVO ADJUSTMENT



1. Remove the four screws that hold the servo hatch on the bottom of the fuselage.

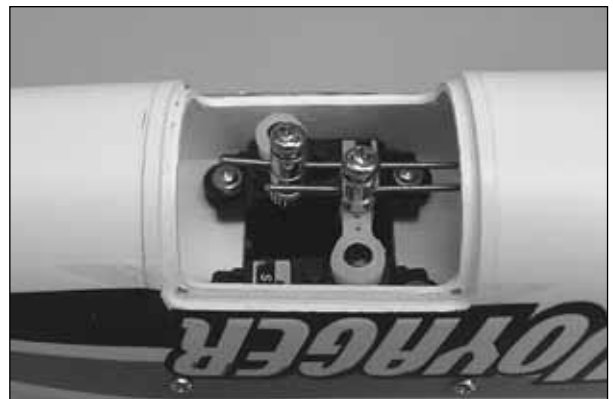

2. Remove the hatch. The decals may need to be trimmed from around the hatch to allow it to be removed.

3. Switch on the transmitter, plug the motor battery into the connector inside the fuselage and switch on the plane. **CAUTION: Stay clear of the propellers.**

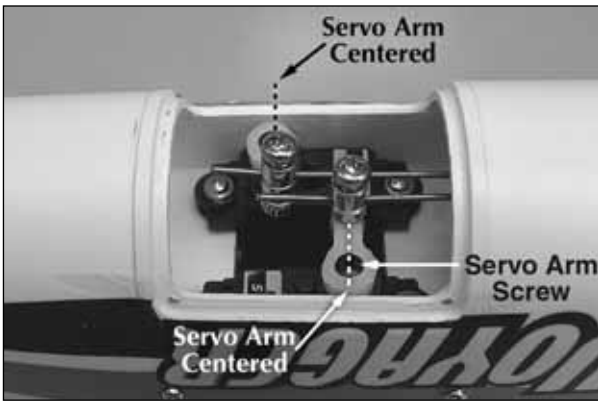

❑ 4. Center the trims on the transmitter as shown on page 8. Check that the servo arms are centered on the servos. If they are not, remove the servo arm screw, remove the servo arm and reinstall it centered on the servo and reinstall the servo arm screw.

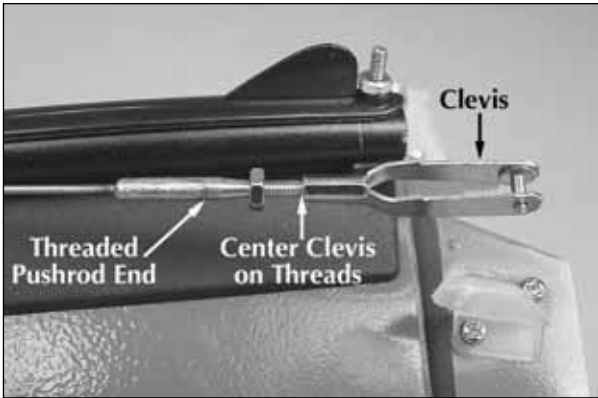

❑ 5. Loosen the nut on the clevis and rotate the clevis to center it on the threaded pushrod end. Re-attach the clevis to the V-tail.

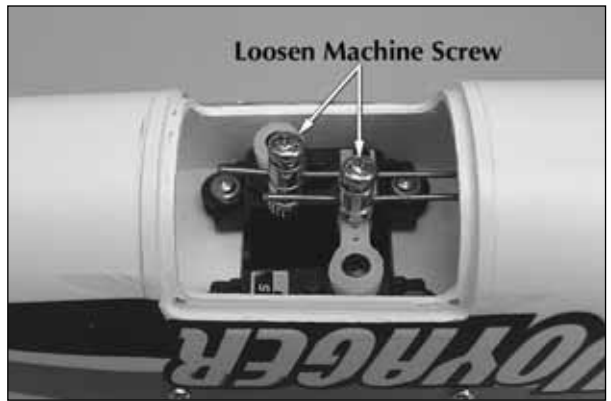

❑ 6. Determine which servo controls the surface that requires adjustment. Loosen the machine screw in the pushrod connector on the servo arm.

❑ 7. Adjust the V-tail so that it is flat as explained on page 8. Retighten the machine screw in the pushrod connector and tighten the nut against the clevis. Reinstall the servo hatch and install the four screws to secure it to the fuselage.

❑ 8. Switch the plane off, then the transmitter. Disconnect the motor battery.

ALSO AVAILABLE

EVADERST



DTXD20**

DuraTrax® Evader™ ST Ready-to-Run

Check it out and you'll agree: *nothing* can touch the 2WD Evader ST electric ready-to-run stadium truck for convenience, set-up ease, performance extras or toughness. It arrives assembled and painted, with a 20-turn Photon Speed™ motor, Sprint™ electronic speed control, and a DuraTrax 2-channel radio system made by Futaba®. Built-in "extras" include: slipper clutch, ball diff, ball bearings, steel universal drives, FREE video and still more. Requires only a 6-7 cell NiCd and charger.