

HOBBICO
SUPERSTAR *EP Select*
Ready-to-Fly *Electric* R/C Trainer

ASSEMBLY INSTRUCTIONS

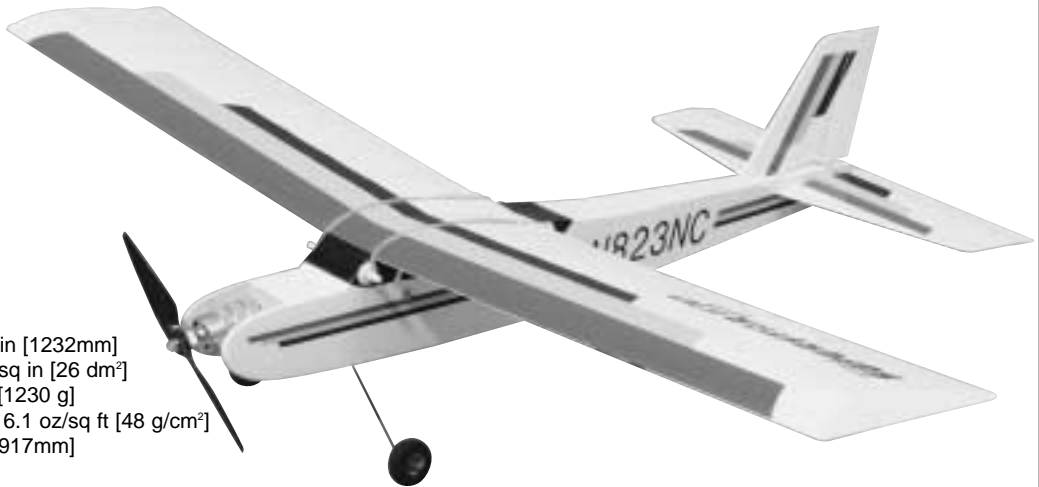

Wingspan: 48.5 in [1232mm]
Wing Area: 400 sq in [26 dm²]
Weight: 43.5 oz [1230 g]
Wing Loading: 16.1 oz/sq ft [48 g/cm²]
Length: 36.1 in [917mm]
Radio: Included
Motor: Included
Electronic Speed Control: Included
Motor Battery: Included

90-DAY LIMITED WARRANTY

If you, as the original owner of this model, discover defects in parts and workmanship within 90 days of purchase, Hobbico will repair or replace it – at the option of our authorized U.S. repair facility, Hobby Services – without charge. Our liability does not include the cost of shipping to us. However, Hobby Services will pay shipping expenses to return your model to you. You must provide proof of purchase, such as your original purchase invoice or receipt, for your model's warranty to be honored. This warranty does not apply to damage or defects caused by misuse or improper assembly, service or shipment. Modifications, alterations or repair by anyone other than Hobby Services voids this warranty. We are sorry, but we cannot be responsible for crash damage and/or resulting loss of kits, motors, accessories, etc.

Your SuperStar EP Select must be returned directly to Hobby Services for warranty work. The address is: **Hobby Services, Attn: Service Department, 1610 Interstate Drive, Champaign, IL 61822-1067. Phone: (217) 398-0007.** Please follow the instructions below when returning your model. This will help our experienced technicians to repair and return it as quickly as possible.

1. ALWAYS return your entire system, including airplane and radio.
2. Disconnect the receiver battery switch harness and make sure that the transmitter is turned off. Disconnect all batteries.
3. Include a list of all items returned and a THOROUGH, written explanation of the problem and service needed. If you expect the repair to be covered under warranty, also include your proof of purchase.
4. Include your full return address and a phone number where you can be reached during the day.

If your model is past the 90 day warranty period or is excluded from warranty coverage, you can still receive repair service through Hobby Services at a nominal cost. Repair charges and postage may be prepaid or billed COD. Additional postage charges will be applied for non-warranty returns. All repairs shipped outside the United States must be prepaid in U.S. funds only. All pictures, descriptions and specifications found in this instruction manual and on the product package are subject to change without notice. Hobbico maintains no responsibility for inadvertent errors.

Table of Contents

Introduction	2
Safety Precautions	2
Decisions You Must Make	3
Battery Selection	3
Chargers.....	4
Additional Items Required	4
Tools	4
Optional Supplies and Tools.....	4
Important Building Notes	4
Kit Contents	5
Ordering Replacement Parts	6
Metric Conversions	6
Assemble the Wing	7
Install the Stabilizer and Fin	7
Install the Landing Gear	8
Install the Wing Dowels	8
Connect Pushrods to Control Surfaces	8
Get the Model Ready to Fly	9
Check the Control Directions	9
Set the Control Throws.....	10
Install the Propeller and Motor Battery	10
Install the Wing on the Fuselage	10
Balance the Model (C.G.)	11
Balance the Model Laterally	12
Proper Care of Your Motor	12
Performance Tips	12
Preflight	12
Identify Your Model	12
Balance Propellers	12
Ground Check	13
Range Check.....	13
AMA Safety Code (excerpt)	13
Check List	13
Flying	14
Takeoff.....	14
Flight.....	14
Landing.....	14

Introduction

Many modelers have learned how to fly with the stable, easy to fly, glow powered SuperStar ARF. Hobbico has taken that stability and ease of flight and produced an electric version. No more fuel bottle, starter, glow driver or noise. All you need to take with you to the flying field is the plane, transmitter, batteries and charger. When you're done flying, just remove the motor battery and put the plane away until the next flying session. No more wiping fuel residue off the plane at the end of the day. So, if you are ready to get started in the exciting world of electric flight, let's get this bird in the air.

An electronic speed control with BEC (Battery Eliminator Circuit) is installed in the SuperStar EP Select. The BEC eliminates the need for a receiver battery. The electronic speed control provides power for the receiver by using the motor battery. As the motor runs, the voltage of the motor battery is reduced. The electronic speed control has a preset voltage. Once the motor battery reaches it, the electronic speed control switches the motor off. This leaves enough power in the motor battery to operate the receiver so that the SuperStar EP Select can be landed safely.

For the latest technical updates or manual corrections for the SuperStar EP Select, visit the web site listed below and select the Hobbico SuperStar EP Select. A "tech notice" box will appear in the upper left corner of the page if there is new technical information or changes to this kit.

<http://www.hobbico.com/airplanes/index.html>

***Protect Your Model, Yourself & Others
Follow these Important
Safety Precautions***

1. Your SuperStar EP Select should not be considered a toy, but rather a sophisticated, working model that functions very much like a full-size airplane. Because of its performance capabilities, the SuperStar EP Select, if not assembled and operated correctly, could possibly

cause injury to yourself or spectators and damage to property.

2. You must assemble the model **according to the instructions**. Do not alter or modify the model, as doing so may result in an unsafe or unflyable model. In a few cases the instructions may differ slightly from the photos. In those instances the written instructions should be considered as correct.

3. You must take time to build **straight, true and strong**.

4. You must use an R/C radio system that is in first-class condition with the appropriate size servos.

5. You must correctly install all R/C and other components so that the model operates correctly on the ground and in the air.

6. You must check the operation of the model before **every** flight to insure that all equipment is operating and that the model has remained structurally sound. Be sure to check clevises or other connectors often and replace them if they show any signs of wear or fatigue.

7. If you are not already an experienced R/C pilot, you should fly the model only with the help of a competent, experienced R/C pilot.

We, as the kit manufacturer, provide you with a top quality kit and instructions, but ultimately the quality and flyability of your finished model depends on how you build it; therefore, we cannot in any way guarantee the performance of your completed model and no representations are expressed or implied as to the performance or safety of your completed model.

Remember: Take your time and follow the instructions to end up with a well-built model that is straight and true.

If you have not flown this type of model before, we recommend that you get the assistance of an experienced pilot in your R/C club for your first

flights. If you're not a member of a club, your local hobby shop has information about clubs in your area whose membership includes experienced pilots.

In addition to joining an R/C club, we strongly recommend you join the AMA (Academy of Model Aeronautics). AMA membership is required to fly at AMA sanctioned clubs. There are over 2,500 AMA chartered clubs across the country. Among other benefits, the AMA provides insurance to its members who fly at sanctioned sites and events. Additionally, training programs and instructors are available at AMA club sites to help you get started the right way. Contact the AMA at the address or toll-free phone number below:



Academy of Model Aeronautics
5151 East Memorial Drive
Muncie, IN 47302-9252
Tele. (800) 435-9262
Fax (765) 741-0057

Or via the Internet at: <http://www.modelaircraft.org>

Decisions You Must Make

This is a partial list of items required to finish the SuperStar EP Select that may require planning or decision making before starting to build. Order numbers are provided in parentheses.

Battery Selection

The SuperStar EP Select was designed to fly on the included 7-cell, 8.4 volt, 2100 mAh motor battery pack. If you are new to electric airplanes (or even cars and boats) here is a short explanation of rechargeable NiCd (Nickel Cadmium) and NiMH (Nickel-Metal Hydride) batteries. A single cell rechargeable battery supplies 1.2 volts with no load (not powering anything). A 7-cell battery pack can supply 8.4 volts (1.2 volts x 7 cells = 8.4 volts). The cell rating in mAh (milli-amp-hours) is the amount of current the battery can supply. If a battery is rated at 2100 mAh, the battery can supply 2.1 amps for 1 hour. This sounds great, flying for an hour on a single battery charge! The bad news is that to produce the

power needed to fly an airplane the size of the SuperStar EP Select, the motor draws from 15-25 amps. The current consumption reduces the run time to 5-8 minutes. The good news is that propellers become more efficient as the speed of the plane increases. This lowers the current draw, allowing the plane to fly longer on a single charge, sometimes up to 20% longer. Also, with an electronic speed control, the motor can be throttled back, increasing the flight time. Most airplanes only need full throttle during takeoff and climbing maneuvers.

Chargers

A fully charged battery pack will provide an initial “surge” of power during the first 15 to 30 seconds of the motor run. Then the power output stays fairly steady for the next several minutes before dropping off quickly. If you do not charge your battery completely, it will not deliver that surge necessary for a good takeoff and climb out. There are at least three ways to “peak-charge” your battery pack.

1. The easiest way is with a “peak-detecting” battery charger. This type of charger will automatically charge your battery until it is fully charged.
2. The second method of charging your motor batteries is to monitor the voltage of your battery pack with a voltmeter. Your charger may have sockets into which you may plug a voltmeter. If not, you may insert the probes from the voltmeter into the rear of the battery plug, making contact with the metal contacts. As your battery charges, the voltage will gradually increase. When the battery is fully charged, the voltage will start to **drop**. At this point your battery is fully charged.
3. The third (and least reliable) method of peak-charging your battery pack is by checking its temperature. As the battery charges it will remain cool until it is fully charged. When it reaches the fully charged state, it will rapidly build up heat. You can feel this heat with your hand. As soon as the pack starts to noticeably warm up, disconnect it from the charger. **Do not continue charging if the battery pack is hot!** Overcharging will damage your battery pack and can result in an explosion.

Additional Items Required

Tools

In addition to common household tools and hobby tools, this is the “short list” of the most important items required to build the SuperStar EP Select.

- Small Phillips and flat blade screwdrivers
- Pliers (HCAR0630)
- Crescent wrench

Optional Supplies and Tools

Here is a list of optional tools that will help you build the SuperStar EP Select.

- Great Planes CG Machine™ (GPMR2400)
- Great Planes AccuThrow™ Deflection Gauge (for measuring control throws, GPMR2405)

Important Building Notes

- **Photos** and **sketches** are placed **before** the step they refer to. Frequently you can study photos in following steps to get another view of the same parts.
- Should repairs ever be required, the SuperStar EP Select’s covering can be patched with Top Flite® MonoKote® purchased separately. MonoKote is packaged in six-foot rolls, but some hobby shops also sell it by the foot. If only a small piece of MonoKote is needed for a minor patch, perhaps a fellow modeler would give you some. MonoKote is applied with a model airplane covering iron, but in an emergency a regular iron could be used.

Kit Contents

Before starting to build, use the **Kit Contents** list to take an inventory of this kit to make sure it is complete and inspect the parts to make sure they are of acceptable quality. If any parts are missing or are not of acceptable quality, or if you need assistance with assembly, contact **Hobbico Product Support**. When reporting defective or missing parts, use the part names exactly as they are written in the Kit Contents list on this page.

Hobbico Product Support
Phone: (217) 398-8970
Fax: (217) 398-7721
E-mail: airsupport@hobbico.com

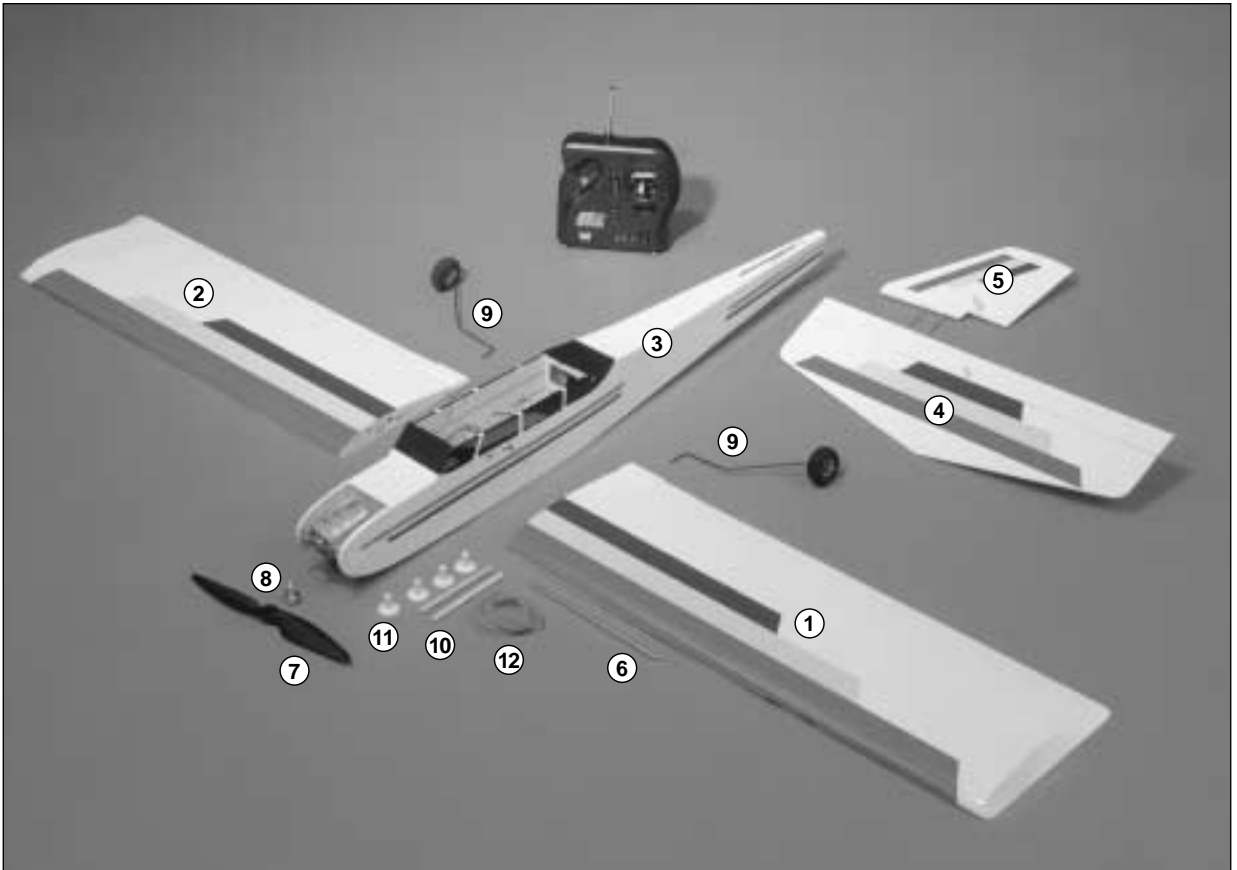

Parts (Photographed)

- | | |
|--------------------------------|---|
| 1. Left Wing (1) | 8. Prop Adapter (1) |
| 2. Right Wing (1) | 9. Main Landing Gear Wires
w/Foam Wheels (2) |
| 3. Fuselage W/Motor (1) | 10. Wing Dowels (2) |
| 4. Stabilizer and Elevator (1) | 11. Wing Dowel Caps (4) |
| 5. Fin and Rudder (1) | 12. Rubberbands (12) |
| 6. Steel Wing Joiner Rod (1) | |
| 7. 9 x 5.5 Propeller (1) | |

Parts (Not Photographed)

- | |
|---------------------------------------|
| (2) Nylon Landing Gear Straps |
| (4) 2.5mm x 8mm Sheet Metal
Screws |
| (1) Wing Joiner Tape |
| (4) 2mm x 6mm Sheet Metal
Screws |

Ordering Replacement Parts

To order replacement parts for the Hobbico SuperStar EP Select, use the order numbers in the **Replacement Parts List** that follows. Replacement parts are available only as listed. Not all parts are available separately (a rudder cannot be purchased separately, but is only available with the tail set). Replacement parts are not available from Product Support, but can be purchased from hobby shops or mail order/Internet order firms. Hardware items (screws, nuts, bolts) are also available from these outlets. If you need assistance locating a dealer to purchase parts, visit www.hobbico.com and click on "Where to Buy." If this kit is missing parts, contact **Hobbico Product Support**.

<u>Item</u>	<u>Description</u>	<u>How to Purchase</u>
Missing pieces		Contact Product Support
Plans	Construction Plans	Plans are not available for ARF models
Hardware	Individual hardware items	Contact your hobby supplier
HCAZ3063	Instruction manual	Contact your hobby supplier
HCAA3035	SuperStar EP Wing Kit	Contact your hobby supplier
HCAA3036	SuperStar EP Fuse Kit	Contact your hobby supplier
HCAA3037	SuperStar EP Tail Set	Contact your hobby supplier
HCAA3039	Motor	Contact your hobby supplier
HCAA3040	Prop / Prop Adapter	Contact your hobby supplier
HCAA3041	Electronic Speed Control	Contact your hobby supplier
HCAA3038	SuperStar EP Landing Gear	Contact your hobby supplier

Warning: The motor, electronic speed control, and prop supplied with the SuperStar EP Select are a matched set and must be used together. Should you choose to change one or more of the supplied components, you will void your warranty on this product.

Metric Conversions

1/64" = .4mm	3/16" = 4.8mm	1" = 25.4mm	18" = 457.2mm
1/32" = .8mm	1/4" = 6.4mm	2" = 50.8mm	21" = 533.4mm
1/16" = 1.6mm	3/8" = 9.5mm	3" = 76.2mm	24" = 609.6mm
3/32" = 2.4mm	1/2" = 12.7mm	6" = 152.4mm	30" = 762mm
1/8" = 3.2mm	5/8" = 15.9mm	12" = 304.8mm	36" = 914.4mm
5/32" = 4mm	3/4" = 19mm	15" = 381mm	

To convert inches to millimeters, multiply inches by 25.4

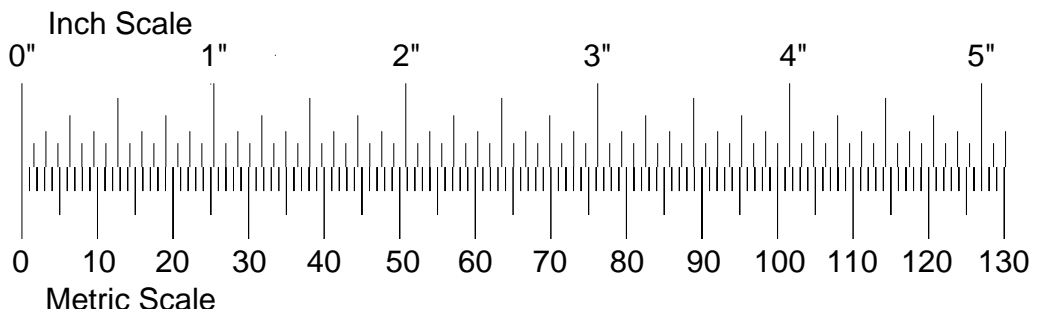

Assemble the Wing

Note: While assembling the plane, remove the motor battery from the plane and charge the battery.

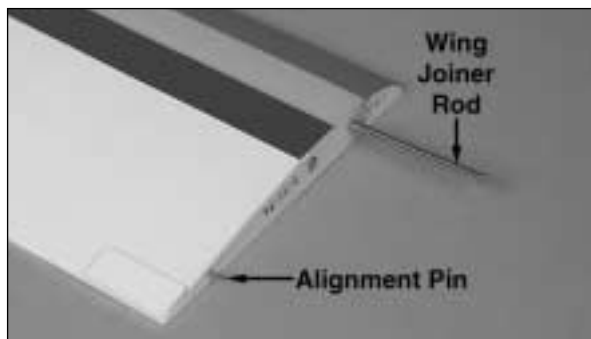

❑ 1. Insert the $7/32$ " x $6-7/8$ " [5.5mm x 174.6mm] **steel wing joiner rod** in the forward hole in the wing root rib of the left wing half. Insert the $3/32$ " x 1" [2.3mm x 25.4mm] alignment pin in the aft hole in the wing root rib.



❑ 2. Join the two wing halves together.

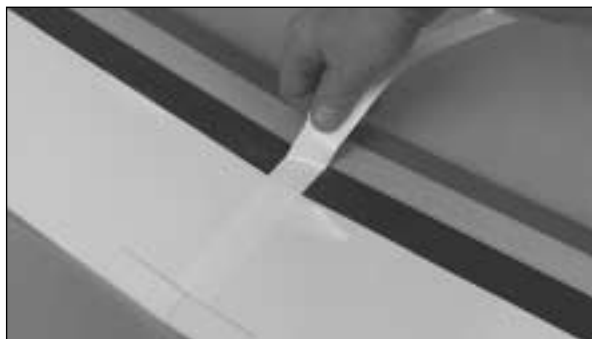

❑ 3. On the top and bottom of the wing, apply the 1" [25.4mm] wide **wing joiner tape** centered on the joint between the two wing halves.

Install the Stabilizer and Fin



❑ 1. Insert the stabilizer and center it in the stabilizer slot. The side with the red, yellow and blue stripe faces upward. The two holes through the stabilizer should be aligned with the fin slot in the top of the fuselage.

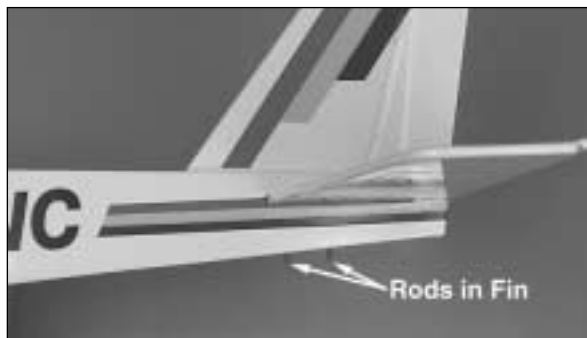

❑ 2. Remove the 2-56 nuts and #2 washers from the fin. Insert the fin in the fin slot. The two threaded rods go through the two holes in the stabilizer and out the two holes in the bottom of the fuselage.

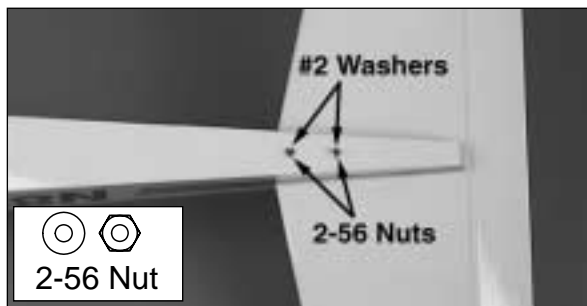

❑ 3. Place a **#2 washer** over each fin rod and secure the fin to the fuselage with **#2-56 nuts**. Do not overtighten the nuts and crush the wood. The nuts should be just tight enough to prevent the stabilizer from moving side to side.

Install the Landing Gear

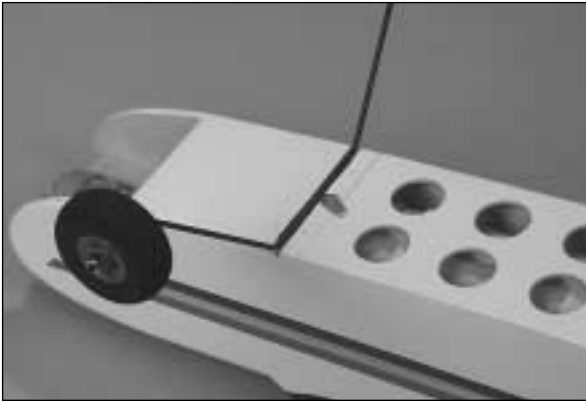

- ❑ 1. Insert the two **main landing gear wires** in the holes, in the slot, at the front of the fuselage.

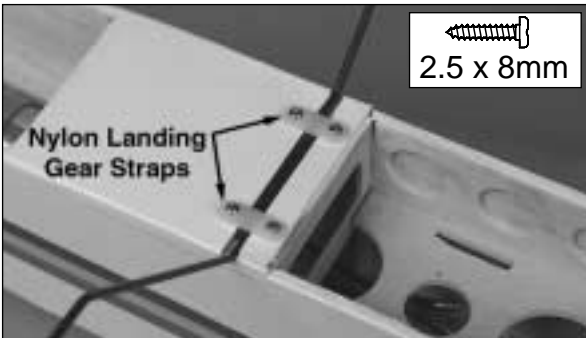

- ❑ 2. Secure the main landing gear wires to the fuselage with two nylon **landing gear straps** and four 2.5mm x 8mm sheet metal screws.

Install the Wing Dowels

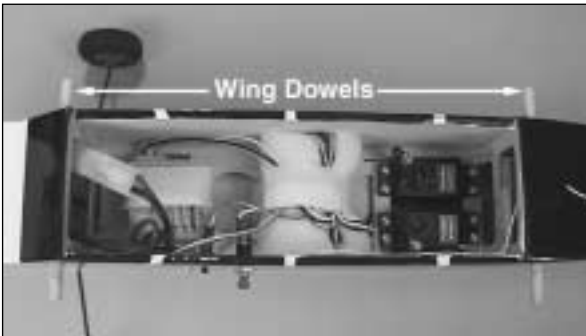

- ❑ 1. Insert and center the 1/4" x 4" [6.4mm x 101mm] **wing dowels** in the holes in the fuselage.

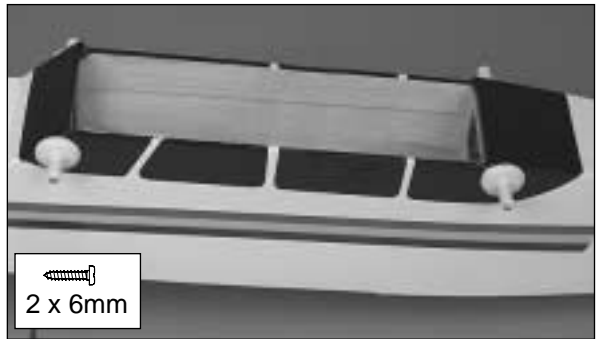

- ❑ 2. Slide a plastic dowel cap over one end of the wing dowel. Secure the **dowel cap** with a 2mm x 6mm sheet metal screw. Install the other three dowel caps and secure them with 2mm x 6mm sheet metal screws.

Connect the Pushrod to the Control Surface

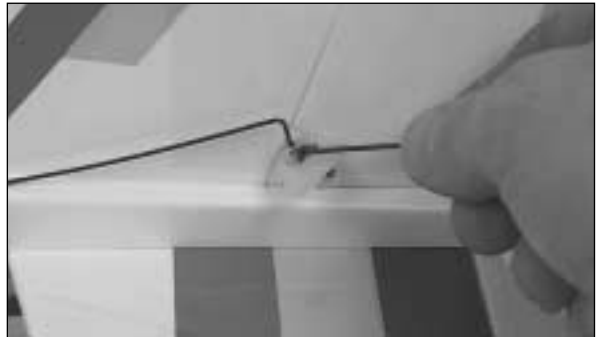

- ❑ 1. Use the .050" hex wrench to remove the wheel collars from the end of the rudder and elevator pushrods.



- ❑ 2. Install the pushrods in the outer holes of the elevator and rudder control horns. Reinstall the wheel collars on the pushrods to secure the pushrods to the control horns.



- ❑ 3. Tape the receiver antenna to the upper side of the fin. Do not shorten the receiver antenna. Shortening the receiver antenna will reduce the receiver's range.

Get the Model Ready to Fly

Check the Control Directions

- ❑ 1. Switch on the transmitter, connect the charged motor battery to the electronic speed control and switch on the speed control. Center the trims. If necessary, remove the servo arms from the servos and reposition them so they are centered. Reinstall the screws that hold on the servo arms.

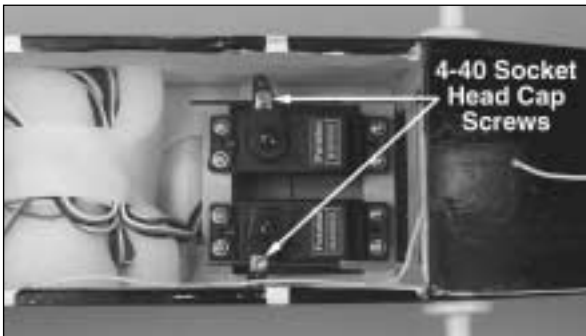
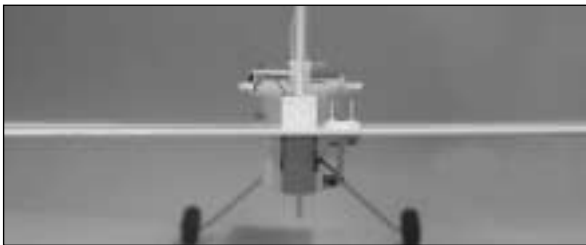

- ❑ 2. With the transmitter and receiver still on, check all the control surfaces to see if they are centered. The top of the elevator should be flat with

the top of the stabilizer and the rudder should be inline with the fin. If necessary, loosen the 4-40 socket head cap screws in the screw-lock pushrod connectors and adjust the pushrods to center the control surfaces.

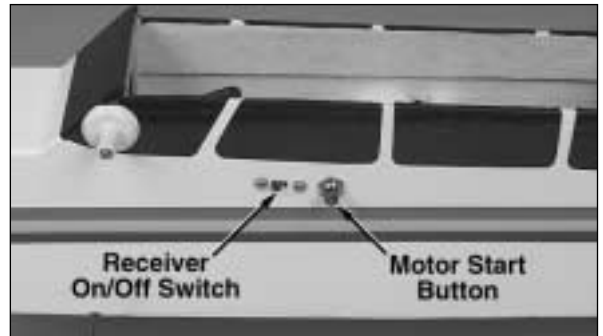
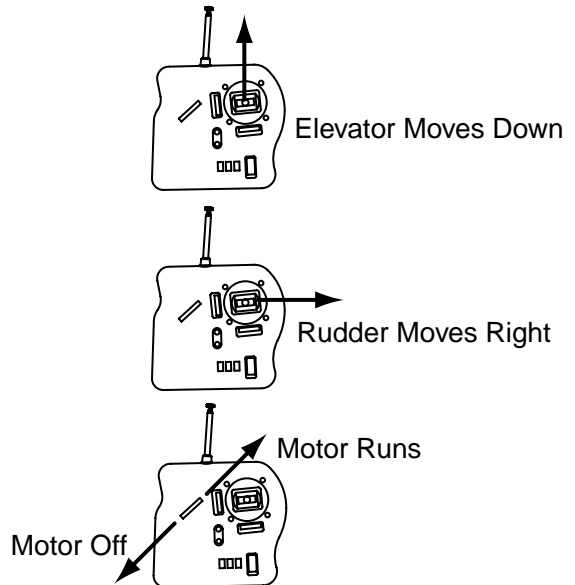

- ❑ 3. Make certain that the control surfaces respond in the correct direction as shown in the diagram. If any of the controls respond in the wrong direction, use the servo reversing switch in the transmitter to reverse the servos connected to those controls. Be certain the control surfaces have remained centered. Adjust if necessary. With the prop still not installed, check that the throttle lever is in the off position or low throttle. To start the motor, the start button must be pressed after the electronic speed control is switched on.

Set the Control Throws

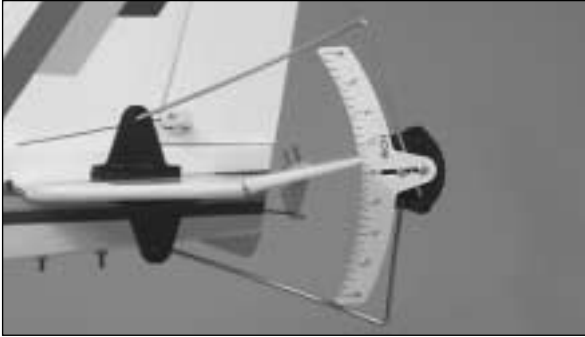

Use a Great Planes AccuThrow (or a ruler) to check the control throw of each control surface as indicated in the chart that follows. **NOTE:** The throws are measured at the **widest part** of the elevator and rudder.

These are the recommended control surface throws:

Elevator:	7/16" [11mm] up 7/16" [11mm] down
Rudder:	5/8" [15.9mm] right 5/8" [15.9mm] left

IMPORTANT: The SuperStar EP Select has been **extensively** flown and tested to arrive at the throws at which it flies best. Flying your model at these throws will provide you with the greatest chance for successful first flights. If, after you have become accustomed to the way the SuperStar EP Select flies, you would like to change the throws to suit your taste, that is fine. However, too much control throw could make the model difficult to control, so remember, "more is not always better."

Install the Propeller and Motor Battery

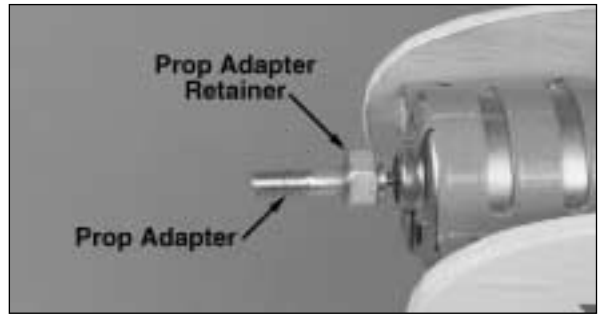

❑ 1. Slide the aluminum **prop adapter** over the motor shaft. Slide the aluminum **prop adapter retainer** over the prop adapter. **Note:** The hole through the prop adapter retainer is beveled. The side with the larger hole goes on first.



❑ 2. Slide the **propeller** onto the prop adapter. The front of the prop has 9 x 5.5 lettering molded into it. Secure the propeller to the prop adapter with the aluminum **prop washer** and **prop nut**. Hold the prop adapter retainer while tightening the prop nut. Make sure the prop is securely attached to the motor shaft.

Install the Wing on the Fuselage

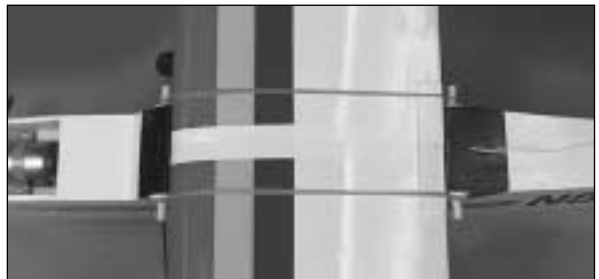

❑ 1. Center the wing on the fuselage. Place a rubberband around the aft wing hold-down dowel and stretch it over the top of the wing, placing it around the forward wing hold-down dowel. Attach a second rubberband on the other side of the fuselage.

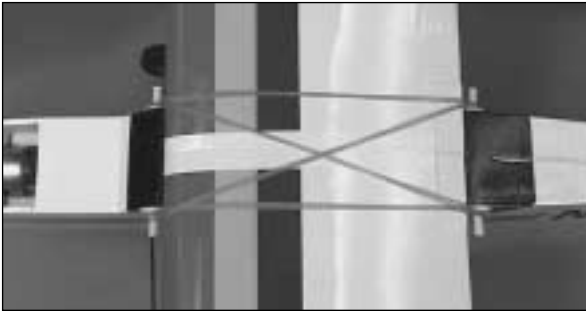

❑ 2. Again place a rubberband around the aft wing hold-down dowel and stretch it over the top of the wing, this time crossing over to the other side of the fuselage before placing it around the forward wing hold-down dowel.

❑ 3. Repeat the process to install the four remaining rubberbands.

Balance the Model (C.G.)

More than any other factor, the **C.G.** (balance point) can have the **greatest** effect on how a model flies and may determine whether or not your first flight will be successful. If you value this model and wish to enjoy it for many flights, **DO NOT OVERLOOK THIS IMPORTANT PROCEDURE.** A model that is not properly balanced will be unstable and possibly **unflyable.**

At this stage the model should be in ready-to-fly condition with all of the systems in place including the motor and prop, electronic speed control, motor battery, radio system and wing installed.

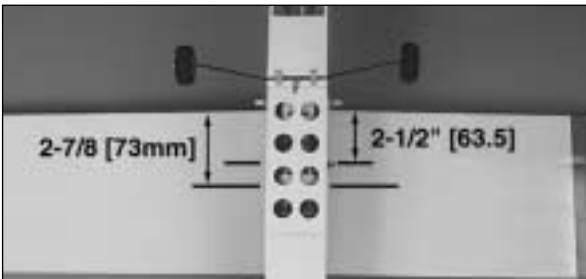

❑ 1. Use a felt-tip pen or 1/8"-wide tape to accurately mark the C.G. range on the bottom of the wing on both sides of the fuselage. **The C.G. range is located between 2-1/2" [63.5mm] and 2-7/8" [73mm] back from the leading edge of the wing.**

Your model must be balanced within this C.G. range. Balancing your model at the forward or aft of the C.G. range will change its flying characteristics. With the plane balanced at the forward C.G. the plane will fly smoother and be more stable, but it may require more speed for takeoff and make it more difficult to slow for landing. This is the best location for the C.G. if you are new to R/C flying. With the C.G. at the back of the C.G. range the plane will be more maneuverable, but could also become too difficult for you to control. In any case, **do not** balance your model outside the recommended range.

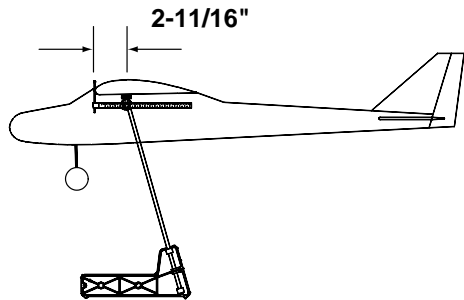

❑ 2. With the wing attached to the fuselage and all parts of the model installed (ready to fly), place the model right-side up on a Great Planes CG Machine™, or lift it right-side up within the balance range you marked.

❑ 3. Have an assistant stand 6' to 8' to the side of the model. As you lift the model, have the assistant observe the stabilizer. If the plane is properly balanced, the stabilizer will be level. If the tail drops, the model is "tail heavy" and weight must be added to the nose to balance. If the nose drops, the model is "nose heavy" and weight must be added to the tail to balance. If additional weight is required, use Great Planes (GPMQ4485) "stick-on" lead. A good place to add stick-on nose weight is beside the motor on the fuselage side. Begin by placing incrementally increasing amounts of weight on the fuse until the model balances. Once you have determined the amount of weight required, it can be permanently attached. If required, tail weight may be added to the underside of the stabilizer.

❑ 4. **IMPORTANT:** If you found it necessary to add any weight, recheck the C.G. after the weight has been installed.

Balance the Model Laterally

❑ 1. With the wing level, have an assistant help you lift the model by the motor shaft and the bottom of the fuselage, under the TE of the stabilizer. Do this several times.

❑ 2. If one wing always drops when you lift the model, it means that side is heavy. Balance the airplane by adding weight to the other wing tip. **An airplane that has been laterally balanced will track better in loops and other maneuvers.**

Proper Care of Your Motor

❑ 1. The included motor will benefit from a short "Break-in" by running it **without the propeller** for at least 1/2 hour. This will seat the motor brushes on the commutator, insuring that the motor will provide full power for your first flight and extending motor life. If you notice a decrease in motor power after a number of flights, it may be due to carbon build-up on the brushes or commutator. To remove this build-up, repeat the above break-in procedure.

❑ 2. The bronze bushings in the motors are self lubricating, but their life may be extended by applying a very small amount of light machine oil to the point where the motor shaft contacts the bushings after every hour or two of run time. **Note:** A drop of oil is far too much. You should apply the oil with a toothpick. **Never oil the inside of the motor.**

❑ 3. Using multiple battery packs to run the motor for successive flights may cause the motor to become excessively hot. We recommend at least a 10 to 15 minute cool-down period between flights.

Performance Tips

❑ 1. A new battery pack should be "cycled" for best results. You should peak charge the battery, then discharge it almost completely by actually running your motor with the propeller attached. Do this 3 or 4 times on the ground before actually flying. Be sure you remove the battery from the airplane between each cycle and allow it to cool before recharging.

❑ 2. Examine your propeller for irregularities caused by the injection molding process. Carefully remove the imperfections with fine sandpaper. Also, make sure your propeller is balanced. Vibration from the propeller will decrease the performance and life of the motor.

Preflight

Identify Your Model

No matter if you fly at an AMA sanctioned R/C club site or if you fly somewhere on your own, you should always have your name, address, telephone number and AMA number on or inside your model. It is **required** at all AMA R/C club flying sites and AMA sanctioned flying events. Fill out the identification tag on the back of this manual and place it on or inside your model.

Balance Propellers

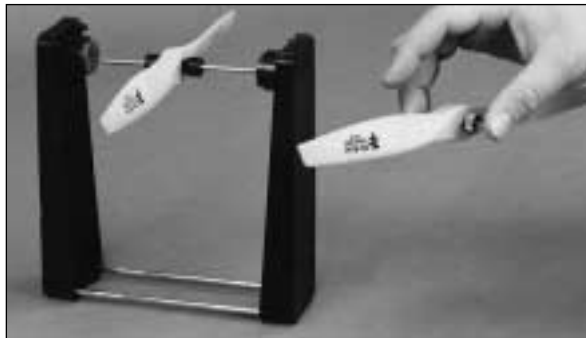

Carefully balance your propeller before you fly. An unbalanced prop can be the single most significant cause of vibration that can damage your model. Not only will mounting screws and bolts loosen, possibly with disastrous effect, but vibration may also damage your radio receiver and electronic speed control.

We use a Top Flite Precision Magnetic Prop Balancer™ (TOPQ5700) in the workshop and keep a Great Planes Fingertip Prop Balancer (GPMQ5000) in our flight box.

Install the propeller on the prop balancer and note which propeller blade rotates to the bottom. This is the heavy blade. To balance the prop, lightly sand the back side of the heavy blade and then recheck it on the prop balancer. This process may need to be repeated several times before the propeller is balanced.

Ground Check

After you break-in the motor on the model, inspect the model closely to make sure all screws remained tight and that the prop, pushrods and pushrod connectors are secure.

Range Check

Whenever you go to the flying field, check the operational range of the radio before the first flight of the day. First, make sure no one else is on your frequency (channel). Have an assistant hold the model, staying clear of the prop. With your transmitter on, you should be able to walk at least 100 feet away from the model and still have control. While you work the controls, have your assistant tell you what the control surfaces are doing. Repeat this test with the motor running at various speeds. If the control surfaces are not always responding correctly, do not fly! Find and correct the problem first. Look for loose servo connections or corrosion, loose bolts that may cause vibration, a defective on/off switch, low battery voltage, a damaged receiver antenna, or a receiver crystal that may have been damaged from a previous crash. If the radio appears to only be affected when the motor is running, try moving your receiver and receiver antenna farther away from the motor battery and motor. Also, installing a couple more capacitors on the motor may help. The capacitors should be soldered from the terminals to the motor case and from one terminal to the other.

AMA Safety Code (excerpt)

Read and abide by the following Academy of Model Aeronautics Official Safety Code:

General

1. I will not fly my model aircraft in sanctioned events, air shows, or model flying demonstrations until it has been proven to be airworthy by having been previously successfully flight tested.

2. I will not fly my model aircraft higher than approximately 400 feet within 3 miles of an airport without notifying the airport operator. I will give right of way to and avoid flying in the proximity of full scale aircraft. Where necessary, an observer shall be used to supervise flying to avoid having models fly in the proximity of full scale aircraft.

3. Where established, I will abide by the safety rules for the flying site I use and I will not willfully and deliberately fly my models in a careless, reckless and/or dangerous manner.

7. I will not fly my model unless it is identified with my name and address or AMA number, on or in the model.

9. I will not operate models with pyrotechnics (any device that explodes, burns, or propels a projectile of any kind).

Radio Control

1. I will have completed a successful radio equipment ground check before the first flight of a new or repaired model.

2. I will not fly my model aircraft in the presence of spectators until I become a qualified flier, unless assisted by an experienced helper.

3. I will perform my initial turn after takeoff away from the pit or spectator areas and I will not thereafter fly over pit or spectator areas, unless beyond my control.

4. I will operate my model using only radio control frequencies currently allowed by the Federal Communications Commission.

Check List

During the last few moments of preparation your mind may be elsewhere anticipating the excitement of the first flight. Because of this, you may be more likely to overlook certain checks and procedures that should be performed before the model is flown. To help avoid this, a checklist is provided to make sure these important areas are not overlooked. Many are covered in the instruction manual, so where appropriate, refer to the manual for complete instructions. Be sure to check the items as off they are completed (that's why it's called a check list!).

- ❑ 1. Check the C.G. according to the measurements provided in the manual.
- ❑ 2. Be certain the motor battery and receiver are securely mounted in the fuse.
- ❑ 3. Extend your receiver antenna and make sure it has a strain relief inside the fuselage to keep tension off the solder joint inside the receiver.
- ❑ 4. Confirm that all controls operate in the correct direction and the throws are set up according to the manual.
- ❑ 5. Make sure all servo arms are secured to the servos with the screws included with your radio.
- ❑ 6. Use an incidence meter to check the wing for twists and attempt to correct before flying.
- ❑ 7. Balance your propeller.
- ❑ 8. Check that the prop nut is tight and that the prop adapter is secure on the motor shaft.
- ❑ 9. Place your name, address, AMA number and telephone number on or inside your model.
- ❑ 10. If you wish to photograph your model, do so before your first flight.
- ❑ 11. Range check your radio when you get to the flying field.

CAUTION (THIS APPLIES TO ALL R/C AIRPLANES): If, while flying, you notice any unusual sounds, such as a low-pitched “buzz,” this may indicate control surface *flutter*. Because flutter can quickly destroy components of your airplane, any time you detect flutter you must **immediately** cut the throttle and land the airplane! Flutter is when a control surface vibrates back and forth very quickly. This vibration can cause the control surface to come off the plane. Check all servo grommets for deterioration (this may indicate which surface fluttered) and make sure all pushrod linkages are secure and free of play. If the control surface fluttered once, it probably will flutter again under similar circumstances unless you can eliminate the free-play or flexing in the linkages. Here are some things which can cause flutter: Not mounting control horns solidly; Side-play of pushrod in guide tube caused by tight bends; Poor fit of Z-bend in control horn; Excessive *play* or *backlash* in servo gears; and Insecure servo mounting.

Flying

The SuperStar EP Select is a great-flying model that flies smoothly and predictably. The SuperStar EP Select possesses the self-recovery characteristics of a primary R/C trainer. However, if you have never flown an R/C plane before, we recommend you get some help from an experienced R/C pilot for your first few flights.

Takeoff

Switch on the transmitter and make sure the throttle stick is back (pulled towards you). Switch on the electronic speed control. If you have dual rates on your transmitter, set them to low. For the first flight have an assistant hand launch the plane for you. This will allow you to have both hands on the transmitter in case the plane is out of trim. To launch the SuperStar EP Select, grip the plane under the wing, keeping all body parts away from the propeller. Switch the motor on and toss the plane level **into the wind**. Allow the SuperStar EP Select to gain speed and climb out at a shallow angle before turning. The SuperStar EP Select can also take off from a hard surface.

Flight

Take it easy with the SuperStar EP Select for the first few flights, gradually getting acquainted with it as you gain confidence. Adjust the trims to maintain straight and level flight. After flying around for a few minutes and while still at a safe altitude with plenty of battery power remaining, practice slow flight and execute practice landing approaches by reducing the throttle to see how the model handles at slower speeds. Add power to see how she climbs as well. Continue to fly around, executing various maneuvers and making mental notes (or having your assistant write them down) of what trim or C.G. changes may be required to fine tune the model so it flies the way you like. Mind your battery power, but use this first flight to become familiar with your model before landing.

Landing

With electric planes it's best to land with some battery power remaining. This will allow you to abort the landing and go around again if needed. To initiate a landing approach, lower the throttle while on the downwind leg. Allow the nose of the model to pitch downward to gradually bleed off altitude. Continue to lose altitude, but maintain airspeed by keeping the nose down as you turn

onto the crosswind leg. Make your final turn toward the runway (into the wind) keeping the nose down to maintain airspeed and control. Level the attitude when the model reaches the landing area, modulating the throttle as necessary to maintain your glide path and airspeed. If you are going to overshoot, smoothly advance the throttle (always ready on the right rudder to counteract torque) and climb out to make another attempt. When you're ready to make your landing flare and the model is a foot or so off the ground, smoothly increase up elevator until it gently touches down.

One final note about flying your model. Have a goal or flight plan in mind for **every** flight. This can be learning a new maneuver(s), improving a maneuver(s) you already know, or learning how the model behaves in certain conditions (such as on high or low rates). This is not necessarily to improve your skills (*though it is never a bad idea!*), but more importantly so you do not surprise yourself by impulsively attempting a maneuver and suddenly finding that you've run out of time, altitude or airspeed. Every maneuver should be deliberate, not impulsive. For example, if you're going to do a loop, check your altitude, mind the wind direction (anticipating rudder corrections that will be required to maintain heading), remember to throttle back at the top and make certain you are on the desired rates (high/low rates). A flight plan greatly reduces the chances of crashing your model just because of poor planning and impulsive moves. **Remember to think.**

Have a ball! But always stay in control and fly in a safe manner.

GOOD LUCK AND GREAT FLYING!

This model belongs to:

Name

Address

City, State Zip

Phone number

AMA number

Cut out or photocopy the identification tag above and tape it to the inside of your model.

Other Fine Products from Hobbico®

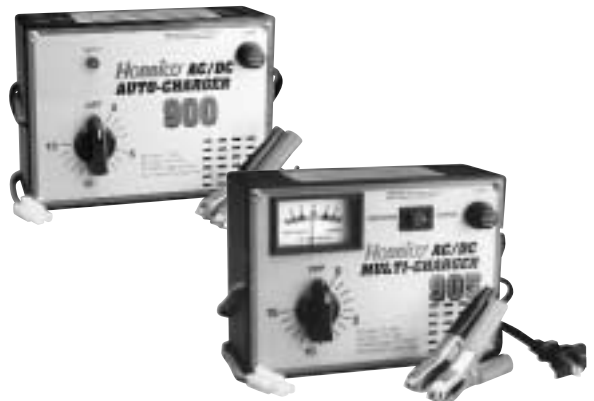

Models 900/905 AC/DC Auto-Chargers

Waiting for cross sell from Wally.

HCAP0125 (900), HCAP0150 (905)

