

ASSEMBLY OF YOUR ELECTRIC FREE-FLIGHT PREDATOR

WARNING: Read instructions carefully! Improper use of this product may result in personal injury or damage to the public.

WARNING: Choking hazard – Small parts. Do not allow children under age 3 to play with the Predator. The model contains small parts which could accidentally be swallowed and cause suffocation. Use with adult supervision.

① INSTALL THE MAIN WING

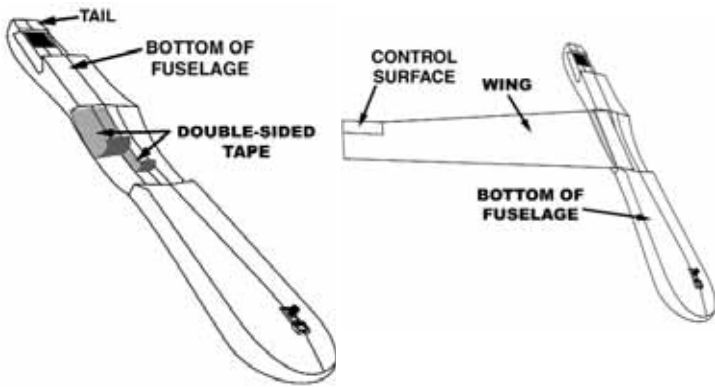

- Remove the backing paper from the double-sided tape on the bottom of the fuselage.
- Attach both wings lining them up with the centerline of the fuselage. The control surfaces need to face the tail of the plane.

② INSTALL THE TAIL

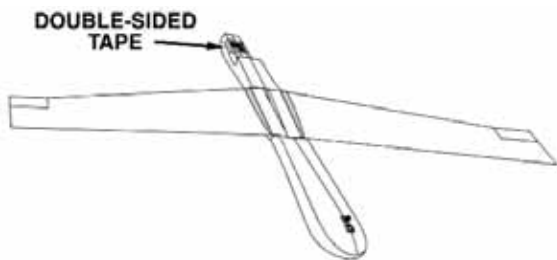

- Remove the backing from the double-sided tape on each side of the fuselage for the tail as shown.

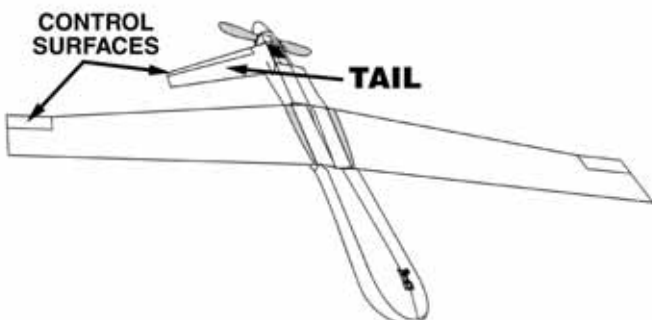

- Attach both stabilizer halves to the fuselage. The control surfaces need to face the propeller.

FLYZONE™
by **Hobbico™**

PREDATOR B
UNMANNED AERIAL VEHICLE
ELECTRIC-POWERED FREE FLIGHT AIRPLANE

Replacement Parts
HCAQ3013 Propeller (2)

Requires: 4 "AA" Alkaline batteries
(Not included)

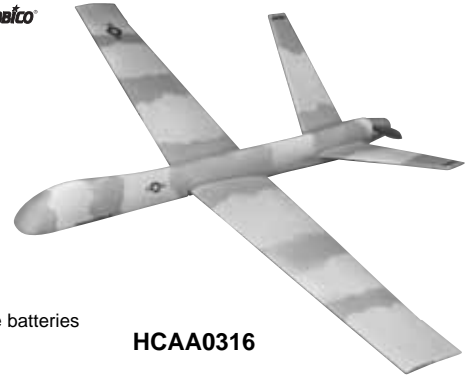

HCAA0316

③ INSTALL THE TAIL

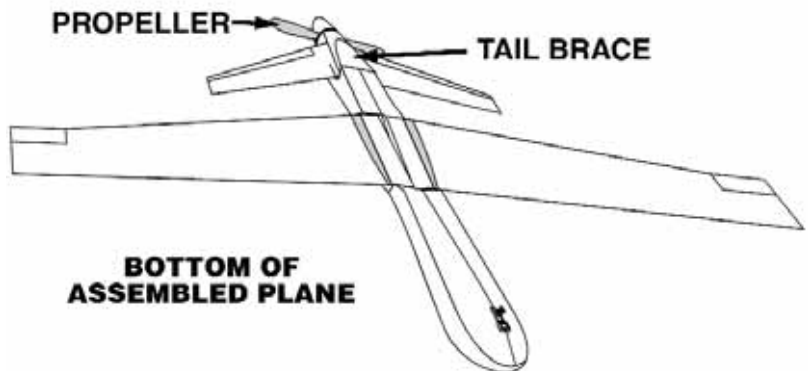
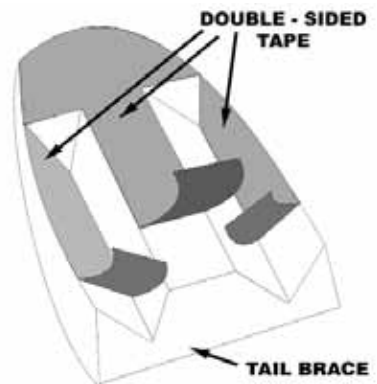

- Locate the tail brace and remove the backing from the double-sided tape.
- Attach the tail brace to the rear of the plane as shown.

CHARGING

1. Remove the back cover of the charger by removing the screws and install 4 "AA" batteries according to the diagram in the charger. Put the cover back on the charger and reinstall the screws. **CAUTION:** Do not use rechargeable (nickel cadmium) batteries. Do not mix old and new batteries. Do not mix alkaline, standard (carbon zinc) or rechargeable (nickel cadmium) batteries.

Warning: This product contains a chemical known to the state of California to cause cancer and birth defects or other reproductive harm.

2. Before charging your free-flight Predator, make sure the "on-off" switch is in the "off" position. (The "off" position is towards the front of the plane.)

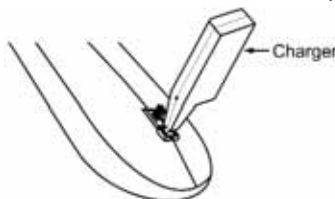

3. Insert the charger into the charge socket on the underside of the Predator. The charger will only fit one way. Match the tab on the charger with the notch on the charge socket.

4. Press and hold the button on the charger to charge the airplane. On the first charge, only charge the Predator for 15 seconds. For longer flights, you may increase the charge time up to 60 seconds. Release the button to stop charging.

5. Never charge the Predator for more than 60 seconds. If you do, you may overheat the battery in the Predator or the charger and damage them.

6. When charging is complete, remove the charger from the Predator.

CAUTION: Keep fingers, face, clothing and other objects away from the spinning propeller.



Attention: The Predator is powered by a rechargeable battery. At the end of the battery's useful life, under various state and local laws, it may be illegal to dispose of the battery into the municipal waste system. Check with local solid waste officials in your area for recycling options or disposal requirements.

WARRANTY

Hobbico, Inc. guarantees this kit to be free of defects in both material and workmanship at the date of purchase. This warranty does not cover any component parts damaged by use or modification. In no case shall Hobbico's liability exceed the original cost of the purchased kit. Further, Hobbico reserves the right to change or modify this warranty without notice. In that Hobbico has no control over the final assembly, no liability shall be assumed nor accepted for any damage resulting from the use of the final user-assembled product. By the act of using the user-assembled product the user accepts all resulting liability. **If the buyer is not prepared to accept the liability associated with the use of this product, the buyer is advised to immediately return this kit in new and unused condition to the place of purchase. Please inspect all parts carefully before starting assembly!** If any parts are missing, broken, or defective, or if you have any questions about assembly or flying of this airplane, please call us at (217) 398-8970, and we'll be glad to help.

TRIMMING YOUR ELECTRIC FREE-FLIGHT PREDATOR (must be done before flying)

1. It is important to adjust, or "trim," your electric free-flight Predator correctly.
2. Before launching the Predator, grasp the airplane fuselage and with the **motor off**, gently toss the Predator into the wind. It should glide straight ahead and settle gently to the ground. See the diagram below.

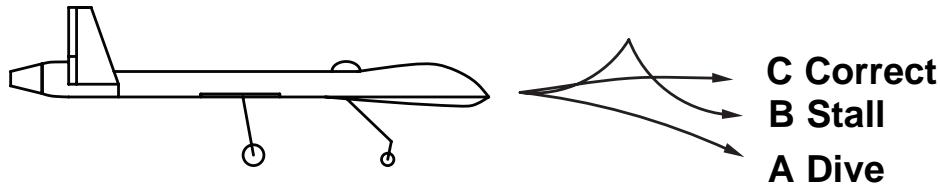

A = Dive. Bend both ruddervators up slightly.

B = Stall. Bend both ruddervators down slightly.

C = Correct flight path.

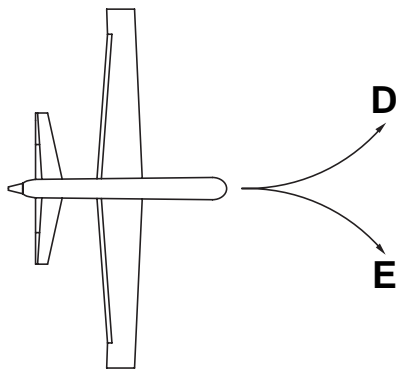

D = To turn left, bend the left ruddervator down slightly and the right ruddervator up slightly.

E = To turn right, bend the right ruddervator down slightly and the left ruddervator up slightly.

3. Repeat step 2 until your airplane glides well.

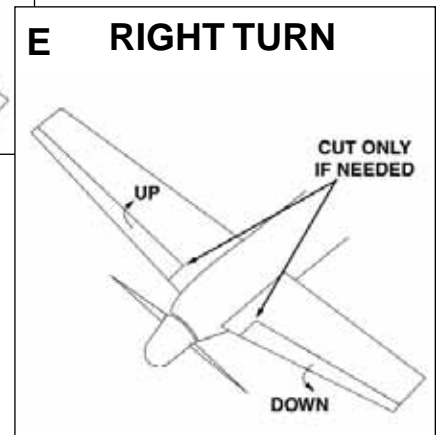
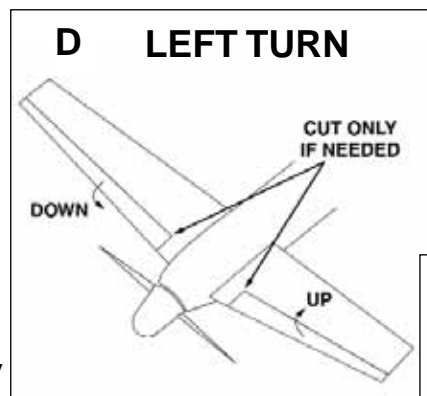
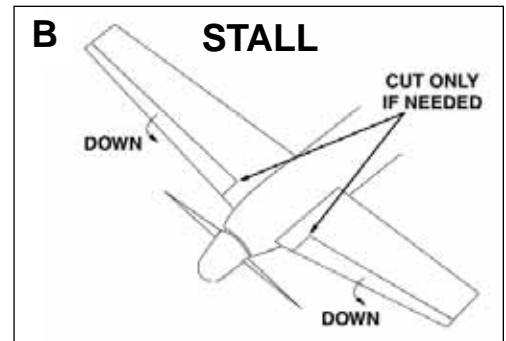
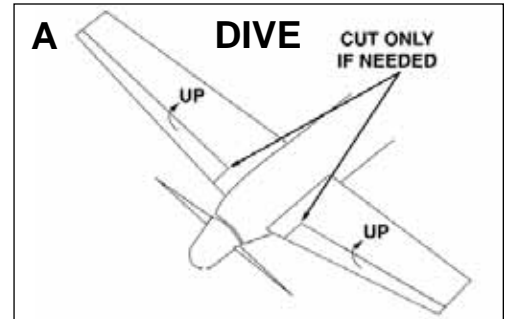

FLYING YOUR ELECTRIC FREE-FLIGHT PREDATOR

SAFETY RULES

- ALWAYS LAUNCH THE AIRPLANE AWAY FROM PEOPLE AND OBSTACLES
- NEVER POINT THE AIRPLANE AT ANYONE OR ANYTHING
- ALWAYS LAUNCH SKYWARD
- DO NOT LAUNCH INDOORS

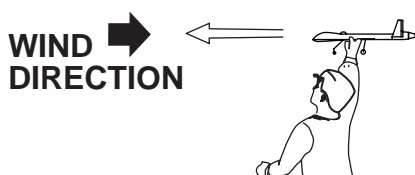

1. Choose an open field, free of trees, power lines and other obstacles. Hold the Predator in your hand over your head and switch on the motor with your other hand. Toss the Predator into the wind, keeping the wing level.

2. The Predator should climb gently and turn gradually. If it stalls and crashes, adjust the ruddervators. If it does not turn, bend the ruddervators slightly up or down. Refer to "TRIMMING YOUR ELECTRIC FREE-FLIGHT PREDATOR" for details.

IMPORTANT THINGS TO REMEMBER WHEN YOU ARE FLYING YOUR FREE-FLIGHT PREDATOR

The most important thing that determines how well your Predator flies is how well you have trimmed it.

Because it can fly high and far, you must fly in a large area away from houses, streets, trees and overhead wires.

Closely inspect your airplane after every flight. Make sure the wing is not broken and is securely attached to the fuselage.

Make sure the tail parts are not cracked or broken. See "Repair" for details.

Always launch the electric free-flight Predator into the wind. Do not fly the airplane if it is too windy.

Never charge your battery for more than 60 seconds. If you do, you may overheat the battery in the Predator or your charger and damage them.

REPAIR: If the fuselage, wings or tail are cracked or damaged, apply white glue and cellophane tape and let dry overnight.

WARNING: Do not use super glue. It will damage the foam.

Hobbico, Inc.
Champaign, IL 61826