

ASSEMBLY OF YOUR ELECTRIC FREE-FLIGHT SPITFIRE

WARNING: Read instructions carefully! Improper use of this product may result in personal injury or damage to the public.

WARNING: Choking hazard - Small parts. Not for children under 3 years. Use with adult supervision.



Replacement Parts HCAP9902 Charger
HCAQ3278 Propeller (2)
HCAA3270 Wing / Tail Assembly

① INSTALL THE PROPELLER

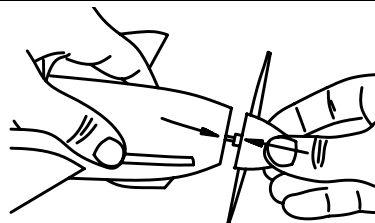

- Install the propeller on the airplane by firmly grasping the airplane's fuselage and pushing the propeller onto the motor shaft. Be sure the propeller is fully seated on the shaft.

② INSTALL THE MAIN WINGS

Top of Wing

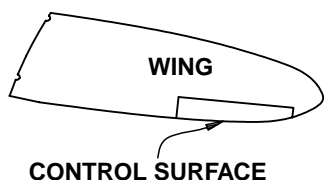

Bottom of Wing

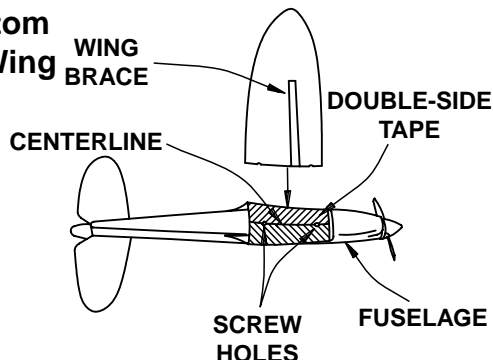

- Remove the backing paper from the double sided tape on the fuselage.
- Attach the main wings to the bottom of the fuselage by lining them up along the centerline of the fuselage. Make sure you are able to see the screw holes between the wings. (see drawing)
- When attaching the main wings to the fuselage, the airplane will be upside down. The wing brace will be upwards only during assembly. The control surfaces need to face the tail of the plane.

③ INSTALL THE WING COVER

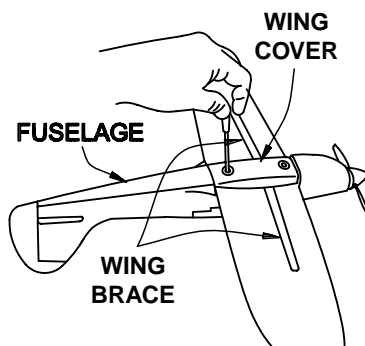

- Note: The front of the wing cover is thicker than the back. The thicker end goes to the front, closest to the propeller.
- Line up the holes in the wing cover and the fuselage. If the thicker part of the cover is not placed to the front, the screw holes will not line up.
- Carefully place the screws through the holes securing the wing cover to the fuselage.
- Tighten the screws securely...DO NOT OVER TIGHTEN.

④ APPLYING THE DECALS

- Using the box photo as a guide, apply the decals to your Spitfire.

CHARGING

1. Remove the back cover of the charger and install 4 "AA" batteries according to the diagram in the charger. Put the cover back on the charger. **CAUTION: Do not** use rechargeable (nickel cadmium) batteries. **Do not** mix old and new batteries. **Do not** mix alkaline, standard (carbon zinc), or rechargeable (nickel cadmium) batteries.
2. Before charging your free flight Spitfire, make sure the "on-off" switch is in the "off" position.
3. Insert the charger into the charge socket on the side of the Spitfire. The charger will only fit one way so match the tab on the charger with the notch on the charge socket.

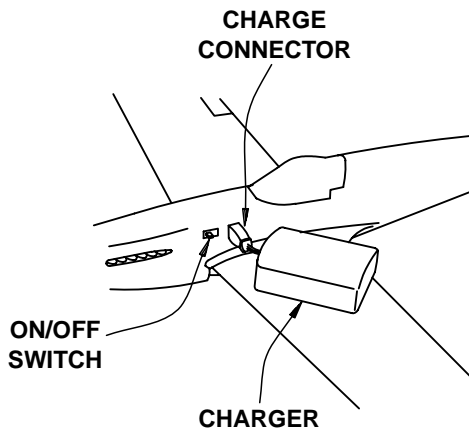

4. On the first charge, only charge the Spitfire for 15 seconds. For longer flights, you may increase the charge time up to 60 seconds.
5. Never charge the Spitfire for more than 60 seconds. If you do, you may overheat the batteries in the Spitfire or the charger and damage them.
6. When charging is complete, remove the charger from the Spitfire

CAUTION: Keep fingers, face, clothing and other objects away from the propeller when running.

WARRANTY

Hobbico, Inc. guarantees this kit to be free of defects in both material and workmanship at the date of purchase. This warranty does not cover any component parts damaged by use or modification. In no case shall Hobbico's liability exceed the original cost of the purchased kit. Further, Hobbico reserves the right to change or modify this warranty without notice. In that Hobbico has no control over the final assembly, no liability shall be assumed nor accepted for any damage resulting from the use of the final user-assembled product. By the act of using the user-assembled product the user accepts all resulting liability. **If the buyer is not prepared to accept the liability associated with the use of this product, the buyer is advised to immediately return this kit in new and unused condition to the place of purchase.**

TRIMMING YOUR ELECTRIC FREE-FLIGHT SPITFIRE (must be done before flying)

1. It is important to adjust, or "trim", your electric free flight Spitfire correctly.
2. Before launching the Spitfire, grasp the airplane fuselage and with the **motor off**, gently toss the Spitfire into the wind. It should glide straight ahead and settle gently to the ground. See the diagram below.

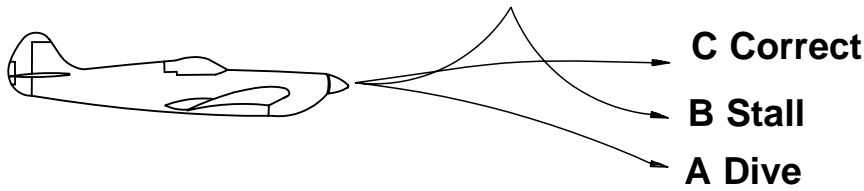

- A** = Dive. Bend elevators upward slightly.
B = Stall. Bend elevators down slightly.
C = Correct flight path.

Elevator Adjustments

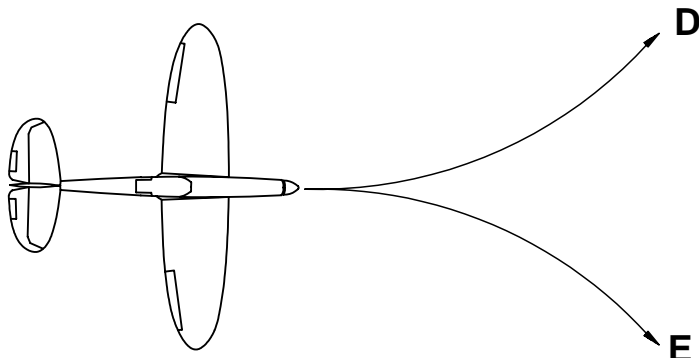
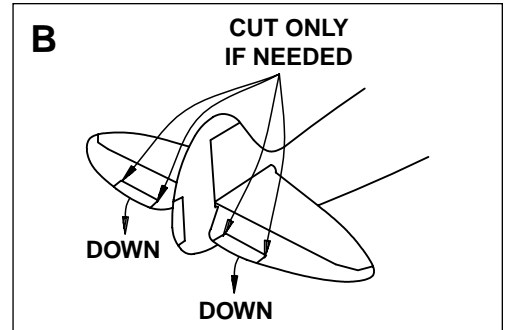
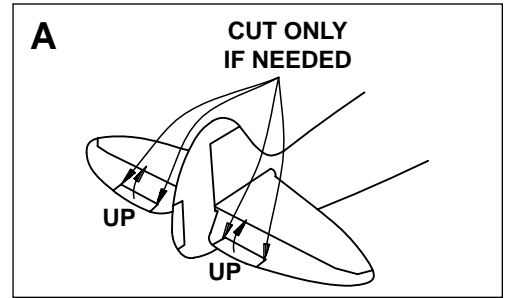

- D** = To turn left, bend the rudder slightly to the left.
E = To turn right, bend the rudder slightly to the right.

Rudder Adjustments

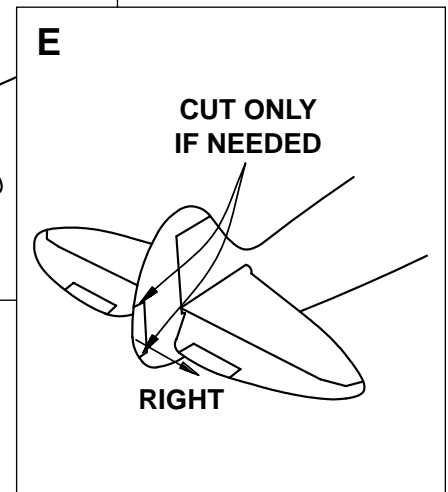
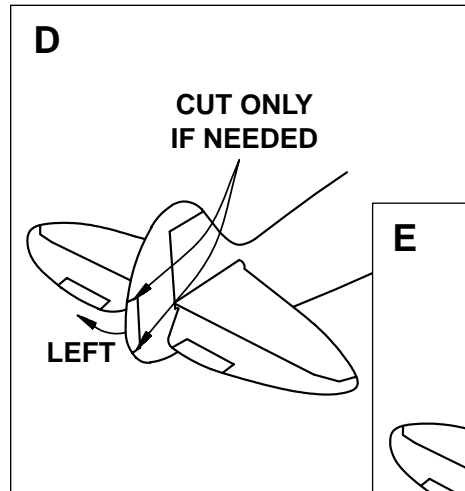

3. If needed, using a hobby knife, carefully cut along the side lines (indentations) on the elevators and rudder as noted in the drawings.
4. Repeat step 2 until your airplane glides well.

FLYING YOUR ELECTRIC FREE FLIGHT SPITFIRE

SAFETY RULES

- ALWAYS LAUNCH THE AIRPLANE AWAY FROM PEOPLE AND OBSTACLES
- NEVER POINT THE AIRPLANE AT ANYONE OR ANYTHING
- ALWAYS LAUNCH SKYWARD
- DO NOT LAUNCH INDOORS

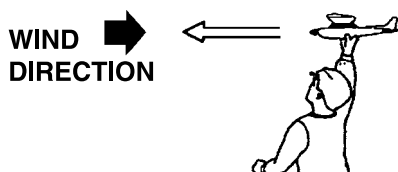

1. Choose an open field, free of trees, power lines and other obstacles. Hold the Spitfire in your hand over your head and switch on the motor with your other hand. Toss the Spitfire into the wind, keeping the wing level.

2. The Spitfire should climb gently and turn gradually. If it stalls and crashes, adjust the elevator. If it does not turn, bend the rudder slightly to the left or right. Refer to "TRIMMING YOUR ELECTRIC SPITFIRE" for details.

IMPORTANT THINGS TO REMEMBER WHEN YOU ARE FLYING YOUR FREE FLIGHT SPITFIRE

The most important thing that determines how well your Spitfire flies is how well you have trimmed it.

Because it can fly high and far you must be in a large area away from houses, streets, trees and overhead wires.

Closely inspect your airplane after every flight. Make sure the wing is not broken and is securely attached to the fuselage.

Make sure the tail parts are not cracked or broken. See the repair section for details.

Always throw the electric free flight Spitfire into the wind. Do not fly the airplane if it is too windy.

Never charge your batteries for more than 60 seconds. If you do, you may overheat the batteries in the Spitfire or your charger and damage them.

REPAIR: If the fuselage is cracked or damaged, apply white glue and cellophane tape and let dry overnight. To replace the tail section, run it under warm water to soften the glue. Gently pull the tail section away from the fuselage. Carefully remove any remaining foam or glue with a hobby knife. Replacement tail sections should be attached using white glue.

WARNING: Do not use super glue. It will damage the foam. If the wing or tail becomes damaged, apply cellophane tape over the damaged area.