



Ages 14+

Read the instruction manual carefully

ITEM NO.:H109S
X4 PRO WITH H7000 TRANSMITTER



THE HUBSAN X4 PRO

REAL TIME FPV

Hubsan X4 PRO

V1.0 2015.01

Read the instruction manual carefully!

IMPORTANT SAFETY NOTES

OPERATION:

Be extremely careful and responsible when using the X4 Pro. Small electronic components can be damaged by crashes or by dropping the X4 Pro in water. To avoid further damage to the unit, people, or property, do not use X4 Pro quads with broken or damaged components.

Flight:

- Fly the X4 Pro responsibly to protect the safety of yourself and others.
 - Do not fly the X4 Pro in crowded places. It needs plenty of space to operate.
 - Do not fly in bad weather.
 - Never try to catch the X4 Pro while it is in flight.
 - This model is intended for experienced pilots age 14+.
 - Power off the X4 Pro after every flight or the propellers may still rotate and cause injury.
 - Always disconnect the battery after every flight to avoid injury from accidentally powering up.
 - High speed propellers are very dangerous. Keep your body clear of propeller arcs at all times.
- The flight system will start after power on regardless of transmitter signal.

SYMBOL EXPLANATION



No operating



Important Notice



Instruction



Explanation, reference

USAGE ADVICE

Hubsan provides you with three files for your X4 Pro:

1. "Disclaimer"
2. "Hubsan X4 Pro Instruction Manual"
3. "Ground Station Instruction Manual"

View the instruction videos and Disclaimer first, then read the manuals.

INDEX

IMPORTANT SAFETY NOTES	02	5 INSTALL THE LEATHER COVER AND SUN-SHADE HOOD	16
SYMBOL EXPLANATION	02	6 PREPARE THE SMART TRANSMITTER	16
USAGE ADVICE	02	6.1 Introduction	17
INDEX	03	6.2 The Installation of Transmitter Battery	18
GENERAL INTRODUCTION	03	6.3 Start the transmitter.	18
1 ACCESSORIES INCLUDED	04	6.4 Method to Bind the Transmitter and X4 Pro	19
2 INTRODUCTION	05	6.5 Introduction of the LCD Interface Function	19
PREPARE FOR USE	05	6.6 Antenna Signal Instruction	19
1 PREPARE THE LIPO BATTERY	06	PREPARATION FOR FLYING	
1.1 LiPo battery in the X4 Pro	06	1.COMPASS CALIBRATION	20
1.2 Charging	06	1.1 Calibration	21
1.3 Power on/ off the X4 Pro LiPo battery	07	1.2 Check GPS Condition	21
1.4 Check The LiPo Battery Power	07	2 START/ STOP THE MOTORS	21
2 SAFETY NOTES	08	3 BASIC FLIGHT	22
2.1 Important Notes	08	4 SIGNAL LOSS PROTECTION FUNCTION	23
2.2 LiPo battery Safety Notes	08	4.1 Conditions Which Activate the Signal Loss Protection Mode	24
3 PREPARE THE X4 PRO	09	4.2 Exiting RTH Mode	24
3.1 Introduction to the X4 Pro	09	5 INTELLIGENT BATTERY ALARM FUNCTION	24
3.2 Prepare the Camera	09	TROUBLESHOOTING	25
3.3 Prepare the 3 Axis Gimbal	12		
3.4 Prepare the Parachute	13		
3.5 Prepare the Propeller set	14		
4 INSTALL 5.8 GHZ TRANSMISSION ANTENNA	15		







GENERAL INTRODUCTION





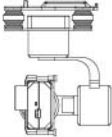

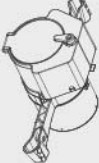
The Hubsan X4 Pro is a high-tech, mid-size quadcopter which is perfect for aerial photography. It is equipped with a stable and accurate 3-axis gimbal, 1080P HD aerial photography camera, and an advanced flight control system. The Android transmitter is capable of long distance camera control, video transmission, ground station automatic flight, FPV flight, social network sharing and even more functions. The Hubsan X4 Pro will help you shoot stable, professional-grade HD videos and pictures.

 **FPV:** First Person View provides a one of a kind flying experience to X4 Pro users. It allows you to see every moment of the flight from the quad's view.

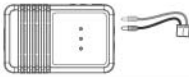
1. ACCESSORIES INCLUDED

Check all the accessories in the package before use.

S/N	Part Name	Photos	Q'ty	Remarks
1	The X4 Pro		1PC	Equipped with smart flight controller,GPS and compass
2	Propellers		4PCS	Propeller A 2pcs, Propeller B 2pcs
3	3-axis stabilized gimbal		1PC	3-axis stabilized gimbal
4	Propeller removal wrench		1PC	For removing propellers
5	Transmitter		1PC	H7000 Smart Transmitter, equipped with a 7.4V 5400mAh rechargeable LiPo battery
6	Parachute		1PC	Stand-alone system, can help provide some safety after a loss of control. (Not included. Purchase this optional accessory from Hubsan)
7	LiPo battery for X4 Pro		1PC	Insert in the X4 Pro
8	LiPo Charger Adapter		1PC	110-240V

9	LiPo Balance charger		1PC	Use to recharge the LiPo battery
10	Propeller guard		4PCS	Ensures the safety of the X4 Pro
11	Micro-USB cable		1PC	To read the camera data
12	User Manuals		4PCS	Disclaimer Hubsan X4 Pro Instruction Manual Camera Instruction Manual Parachute Instruction Manual
13	1080P camera		1 PC	HD camera module
14	Transmitter Antenna		1 PC	5.8 GHz Transmitter Antenna
15	Video glasses		1 PC	Video glasses (Not included. Purchase this optional accessory from Hubsan)

2. INTRODUCTION

The Hubsan X4 Pro system consists of the quadcopter, camera, gimbal, parachute, propeller guard, power system, flight control system, and radio transmission system.

Transmitter equipment: dual data transmission, map and track display, waypoints set/auto-flight, FPV transmission mode, Video and picture shooting modes.

X4 Pro equipment: 3-axis gimbal, camera, power system (brushless motors and propellers), parachute (available separately), propeller guard.

X4 Pro working Mode: Altitude Hold Mode, Position-hold Mode, Waypoint Mode, RTH Mode, Headless Mode.

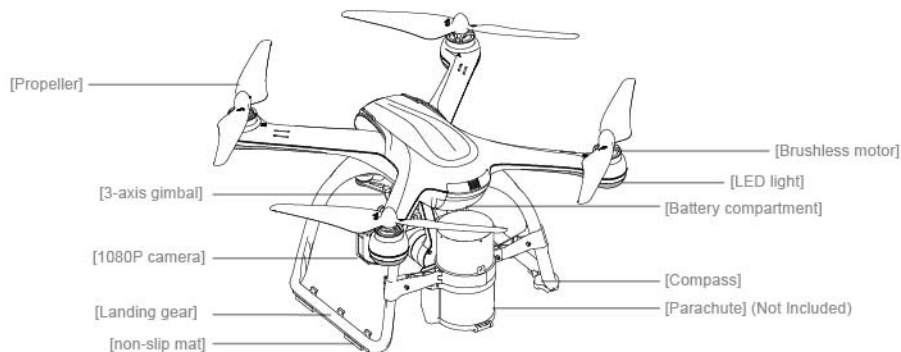

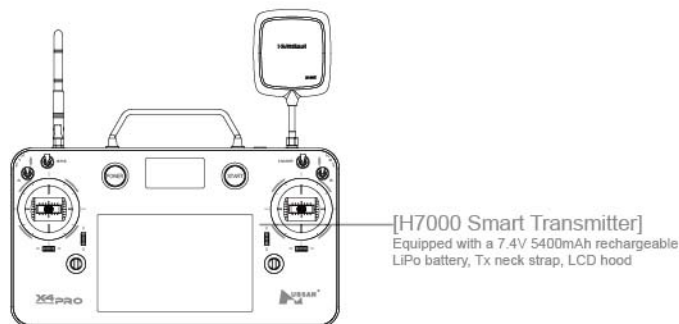

PREPARATIONS FOR USE

Thanks for buying HUBSAN products!

1 PREPARE THE LIPO BATTERY

Make sure the following equipment is fully charged before flight.

EQUIPMENT	SUPPLIED POWER
Transmitter	7.4V 5400mAh rechargeable LiPo battery
Camera	3.7V 650mAh rechargeable LiPo battery
X4 Pro with gimbal	Both powered by 11.1V 7000mAh rechargeable LiPo battery
Parachute	3.7V 380mAh rechargeable LiPo battery

1.1 LIPO BATTERY IN THE X4 PRO

The X4 Pro is equipped with a 11.1V, 3 cell, 7000mAh rechargeable LiPo battery. Always charge the LiPo battery with the Hubsan charger.

BATTERY SPECIFICATIONS

Charging temperature: 0°C~40°C

Discharging temperature: - 20°C~50°C

Charging/ Discharging humidity: < 80%

1.2 CHARGING

Connect battery to balance charger and wall charger. The two LED lights will turn red when charging and turn green when charging is finished. The charging time is about 180 min.

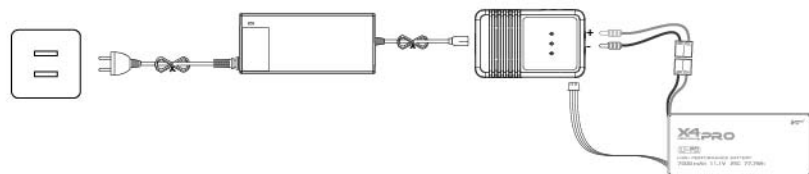

-  **(1) Overcharge protection** Overcharge protection prevents battery damage by automatically ending charging when the battery reaches 12.8V.
- (2) Over-discharge protection** Over-discharge protection protects the battery by cutting off power when the battery reaches 8.4V.
- (3) Short circuit protection** Short circuit protection powers off the X4 Pro as soon as a short circuit is detected.

1.3 POWER ON/ OFF THE X4 PRO LIPO BATTERY

Power on: Put the battery into the battery compartment and connect the battery plug with the correct polarity. When the X4 Pro is on, the blue LEDs on X4 Pro will blink in a rotating pattern.

Power off: Disconnect the battery connector plug to remove power from the X4 Pro. The LEDs will turn off.

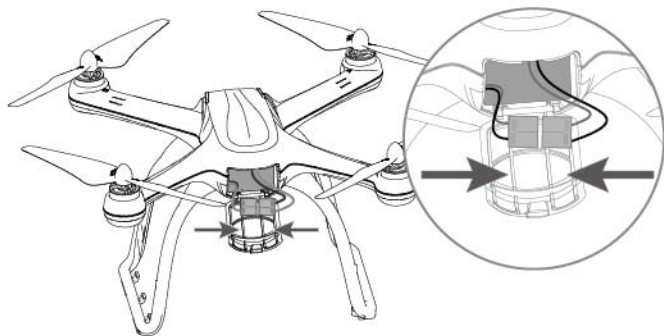

1.4 CHECK THE LIPO BATTERY POWER

After the X4 Pro and the Transmitter finish pairing, the battery power will display on the tablet.

BATTERY POWER			
BAT	65%	TIME	00:19
TX	35%	DIST	0m
RF	88%	ALT	+ 3m
GPS	0	DIR	NE
ALT	Hold		Headless
	Low Battery TX		

Always partially charge your LiPo battery before storage.

LiPo batteries retain a charge over a long period at about a 50% or 3.5V per cell storage charge. It is not normally necessary to recharge stored LiPo batteries unless stored for periods longer than 3-6 months.

If your LiPo battery has been over-discharged, it will not be possible to recharge it again.



LiPo Battery Disposal & Recycling



Lithium-Polymer (LiPo) batteries must not be placed in with household trash. Please contact your environmental or waste agency or the supplier of your model for local regulations and the location of your nearest LiPo battery recycling center.

2 SAFETY NOTES

2.1 IMPORTANT NOTES

This X4 Pro is not a toy. Any improper use of this product will result in serious injury. Be aware of your personal safety, the safety of others and your surrounding environment. We recommend beginners learn to fly with the assistance of experienced pilots. **It is your responsibility to comply with your country's remote controlled and Unmanned Aerial Vehicle flight regulations!**

2.2 LIPO BATTERY SAFETY NOTES

The X4 Pro is powered by a lithium-polymer (LiPo) battery. To avoid risk of fire or damage, never recharge your battery while it is inserted in the plane. If you do not plan to fly the plane for a week or more, store the battery approximately 50% charged to maintain battery performance and life.



SAFETY ADVISORY NOTICE

Lithium-Polymer (LiPo) Batteries

LiPo batteries are different from conventional batteries in that their chemical contents are encased in a relatively lightweight foil packaging. This has the advantage of significantly reducing their weight, but does make them more susceptible to damage if roughly or inappropriately handled. As with all batteries, there is a risk of fire or explosion if safety practices are ignored:

- Charge and store LiPo batteries in a location where a battery fire or explosion (including smoke hazard) will not endanger life or property.
- Keep LiPo batteries away from children and animals.
- Never charge the LiPo battery that has ballooned or swelled.
- Never charge the LiPo battery that has been punctured or damaged.
- After a crash, inspect the battery pack for signs of damage. Discard in accordance with your country's recycling laws.
- Never charge the LiPo battery in a moving vehicle.
- Never overcharge the LiPo battery.
- Never leave the LiPo battery unattended during recharging.
- Do not charge LiPo batteries near flammable materials or liquids.
- Ensure that charging leads are connected correctly. Reverse polarity charging can lead to battery damage, fire, or explosion.
- Have a suitable fire extinguisher (electrical type) OR a large bucket of dry sand near the charging area. Do not try to extinguish (LiPo) battery fires with water.
- Reduce risks from fire/explosion by storing and charging LiPo batteries inside a LiPo charge sack.
- Protect your LiPo battery from accidental damage during storage and transportation. (Do not put battery packs in pockets or bags where they can short circuit or can come into contact with sharp or metallic objects.)
- If your LiPo battery is subjected to a shock (such as a crash), place it in a metal container and observe for signs of swelling or heating for at least 30 minutes.
- Do not attempt to disassemble, modify, or repair the LiPo battery.

3 PREPARE THE X4 PRO

3.1 INTRODUCTION TO THE X4 PRO

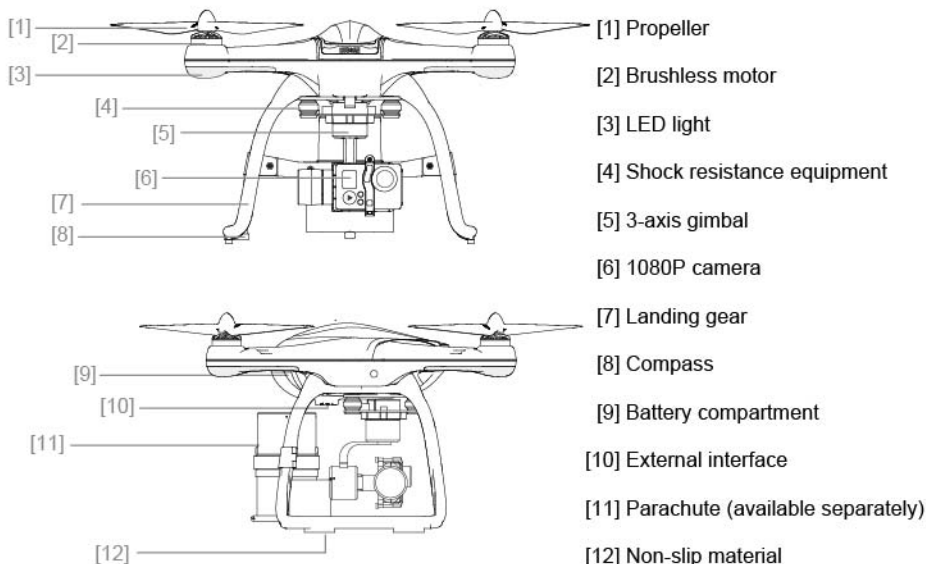

3.1.1 FLIGHT CONTROL SYSTEM INTRODUCTION

The Hubsan X4 Pro is easy to operate and very stable. It is capable of all basic flight actions and also includes control loss failsafes, a power alarm, and IOC functions.

Modules on flight control system	Function
Main Control Module	CPU of the flight control system, connects to all the modules for central control processes.
IMU Module	Includes inertial sensor, stabilizes flight; includes a barometer to measure the flight altitude.
GPS & Compass Module	Position hold and Navigation.
LED indicating lights	Indicating the flight control system's condition.

3.2 PREPARE THE CAMERA

Insert battery into the camera and attach the camera onto the gimbal. Power on the camera. You can press the buttons on the camera to shoot pictures and videos. Users can also use the H7000 transmitter to record and play back the videos.

Camera specifications			
Recording resolution	1920*1080 Full HD	Battery	3.7V 650mAh
Recording frame rate	30FPS	Working temperature	10~+70°C
Video format	MOV	Working humidity	30%~80%
Image Sensor	3 million pixel MJPG	Working power	1.9W
Image pixel	4032*3024 pixel	Standby power	1.33W
Lens format	1/3"	Storage temperature	- 40~+125°C
Lens FOV	170 ° (MAX)	Storage humidity	30%-90%

3.2.1 CAMERA BUTTONS INSTRUCTION

Power on/off: Press the power button(<2sec), power on;
Hold down the power button(≥2sec), power off.

Video shooting: Press the video button, start recording;
Hold down the video button, stop recording.

NOTE: You can shoot pictures or videos through the H7000 touch screen. For more details, please refer to *Ground Station Instruction Manual*.

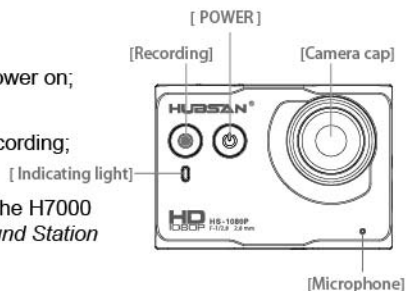

3.2.2 MICRO-SD CARD

Only insert or remove the micro memory card when the power is off. Picture nine shows where to insert the memory card.

A micro memory card is not included in the Hubsan X4 Pro package. Users must supply their own class 4-6, 4GB-32GB memory card and format it before use.



- ⊘ Do not insert/remove the Micro-SD card when the camera is powered on. Doing so can corrupt the SD card and files.
- Format your micro memory card by pressing the recording button for 5 seconds, or format it for 32KB size allocation unit on a computer before installing it in the camera.

3.2.3 READING DATA AND CHARGING THE CAMERA

With the camera on, use the included Micro-USB cord to connect to a computer and copy your pictures and videos over to the hard drive.

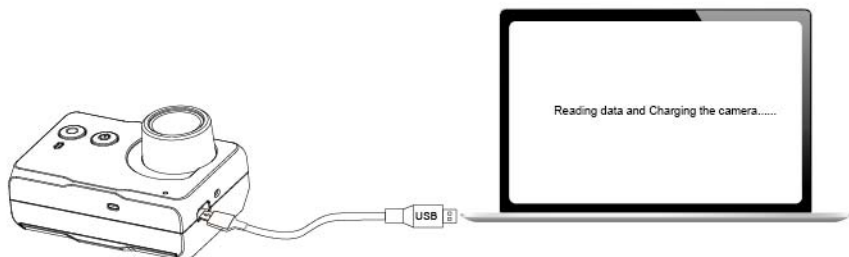

- ⚠ • Files can only be transferred while the camera is on. The camera will only recharge from the computer when the camera is off. The camera cannot take additional photos or video while connected to the PC.
- Remove the USB connector from the camera while shooting, it will still be shooting. The camera will automatically power off when USB is disconnected from computer.
- The camera will recharge while connected to the X4 Pro or the PC. It recharges at about 500mAh and has a 3.7V/670mAh battery.

3.2.4 CAMERA LIGHTS

Camera LIGHT	Camera condition
Blue light turns on	Standby
Blue light turns on, red light blinks once every second	Recording
Blue light turns on, red light turns on	Camera module is faulty
Blue light blinks every second	Micro-SD card will be full/ no SD card/ faulty SD card
Blue light blinks quickly	Micro-SD card is full
Red light blinks quickly	Battery power is low

3.2.5 INSTALL THE CAMERA

- Method: 1. Unscrew and remove the camera mount.
2. Put the camera on the slot (camera facing out) and reinstall the camera mount with screws.
 3. Plug the camera data wire into the USB interface. Plug the other end into the X4 Pro external interface (see more details on 3.3.1).

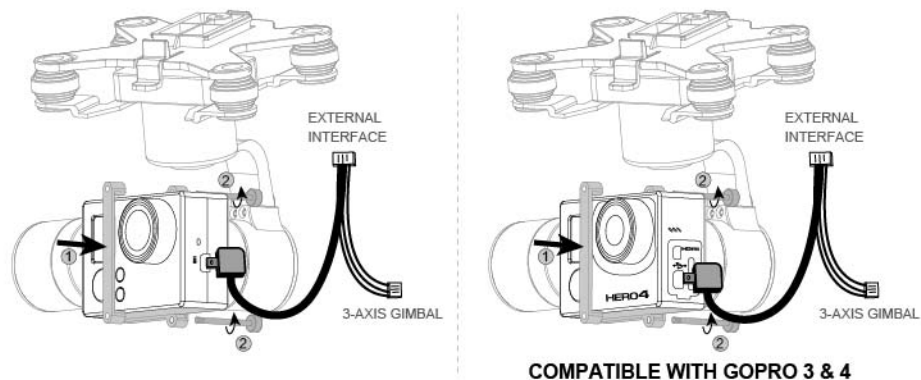

GoPro 3 & 4 are compatible with the X4 Pro. You can install the camera according to the above method. Connect the camera to the X4 Pro with Hubsan provided USB cable. While the H7000 can control Hubsan camera to shoot pictures or videos through its touch screen, it cannot control GoPro 3 & 4 accordingly. You need press buttons on the GoPro camera to shoot pictures or videos.

3.3 PREPARE THE 3-AXIS STABLE GIMBAL

Features of the gimbal	
Control accuracy	$\pm 0.03^\circ$
Control range	Pitch angle: $+65^\circ \sim -125^\circ$ Horizontal angle: $\pm 145^\circ$
Stabilized design	$\pm 40^\circ$ rotation, rotates automatically when the X4 Pro tilts to ensure stable filming

3.3.1 INSTALL THE 3-AXIS GIMBAL

Step 1: Remove the 3 axis gimbal from its box, position it at the bottom slot with shock resistance equipment slot and slip into the bottom of the frame.

Step 2: Insert the gimbal signal wire into the slot on the gimbal.

Step 3: Insert the camera image transmission wire into the left slot.

Step 4: Connect the power plug.

After installation, power on the X4 Pro and the 3 axis gimbal will power on and adjust automatically. The T1 and T2 rotary switch can also be used to control gimbal rotation.

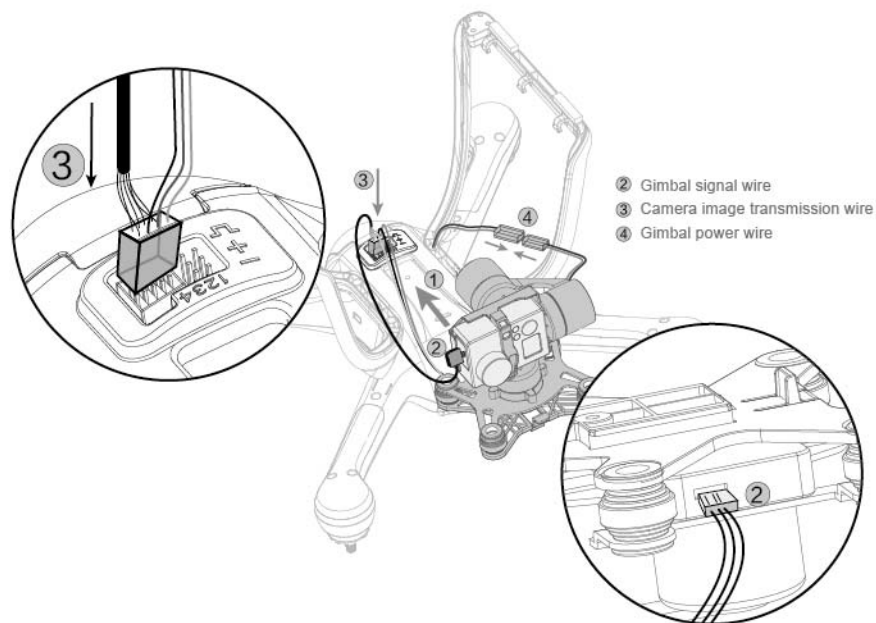

3.3.2 INSPECTING THE GIMBAL AND HANDLING ERRORS

- ⚠ • Abnormal gimbal alignment may be due to a crash, hit, or non-level surface. For correct gimbal alignment, place the X4 Pro on a clear, level surface before flight where there will be no obstructions to gimbal rotation when it turns on.
- Flying in fog or clouds can cause condensation and lead to faulty gimbal alignment. Allow the gimbal to dry before use.

3.4 PREPARE THE PARACHUTE

Refer to *The Parachute Instruction Manual*

A parachute set is available separately from Hubsan for the X4 Pro. This parachute operates even when the X4 battery is running out. An inner sensor in the parachute detects abnormal flying conditions and will automatically deploy the parachute for a safe landing.

3.4.1 INSTALL THE PARACHUTE SYSTEM (OPTIONAL PURCHASE FROM HUBSAN)

Step 1: Install the attachment set.

Take the parachute set from the box, remove the screws from the bracket and open the buckle; make sure the direction of the attachment set is up as the arrows show. Put the attachment set onto the landing gear until it is positioned in the slot. Tighten the screws to the attachment set as the picture shows:

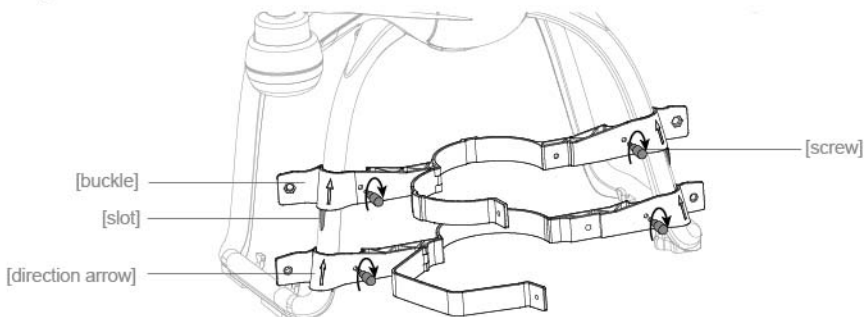

- ⚠ • Pay attention to the direction of the arrows on the attachment set. These arrows should point straight up.
- Make sure to line the attachment set up with the slot before attaching it with screws. Improper attachment can cause instability and in-flight vibration.

Step 2: Install the parachute canister:

Position the parachute canister into the attachment set and tighten the screws. Attach the parachute to the attachment set using clamps and screws. (Refer to The Parachute Instruction Manual for more information)

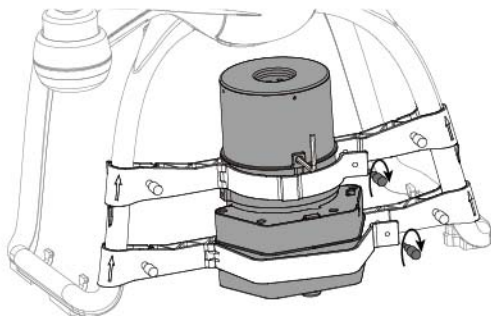

3.5 PREPARE THE PROPELLER SET

The Hubsan X4 Pro is equipped with gray and black 9 inch propellers. Propellers are the most likely part of the quad to be damaged. Spares are available through Hubsan.

3.5.1 INTRODUCTION

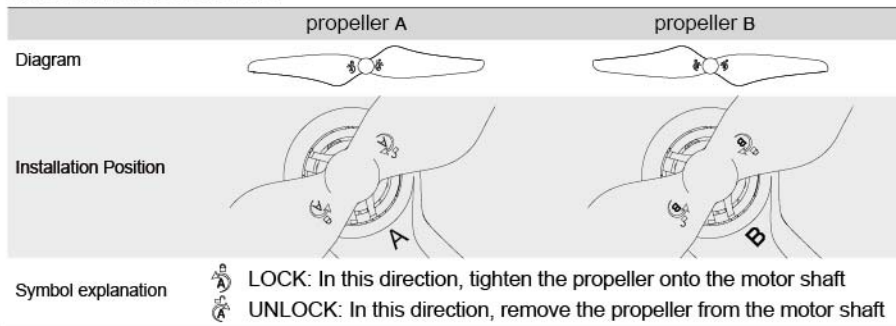

3.5.2 METHOD

Take out the four propellers and install them tightly on the corresponding motor shafts.

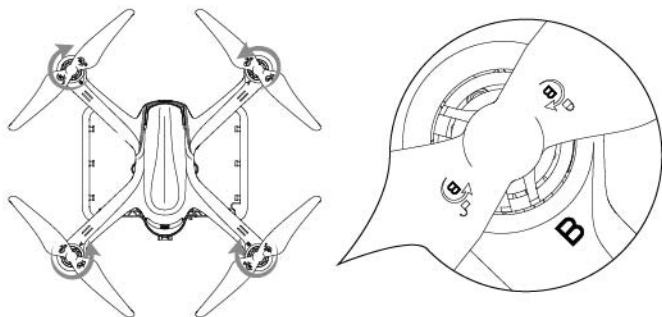

- ⚠ • The propellers are designed to tighten easily. Do not screw them too tight and do not use glue to attach them to posts.
- Make sure that the black and gray, A and B propellers are installed correctly. The model will not fly if propellers are improperly installed.
- Wear gloves when installing the propellers to avoid scratches from the thin, sharp propellers.

3.5.3 REMOVE PROPELLER

Hold the motor with the Propeller removal wrench. Remove the propeller by rotating it counter-clockwise to unlock.

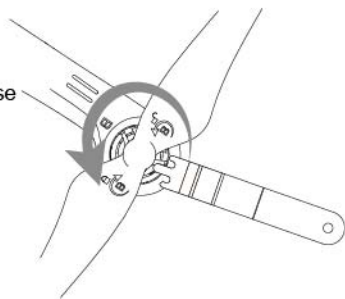

- ⚠ • Check that the propellers are correctly installed and tight before every flight.
- Check to see that the propellers are in good condition. Exchange broken, aging, or poor quality propellers before every flight.
- To avoid injury, do not touch the high-speed props or motors during operation.
- Always use Hubsan propellers to ensure best flight experience.

3.5.4 PREPARE THE PROPELLER GUARD

Propeller guards are optional, but we recommend that beginners use them to facilitate safe flying.

Method: Fasten the screws to install the propeller guard as the below picture shows.

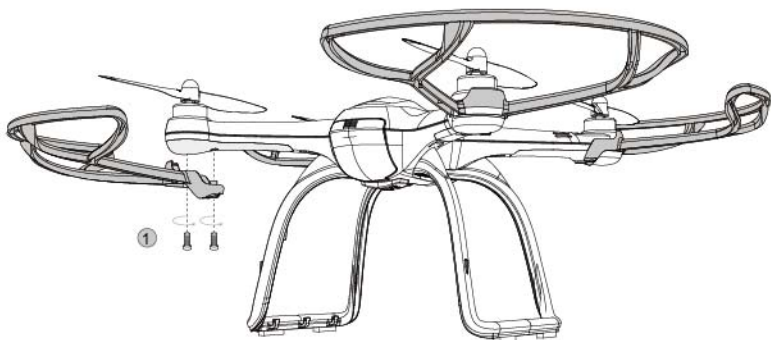

4 INSTALL 5.8 GHZ TRANSMISSION ANTENNA

Method: 1) Align the antenna with its connector on the X4 Pro. Turn clockwise to fasten it.
2) Make sure the antenna is straight and in line with the undercarriage.

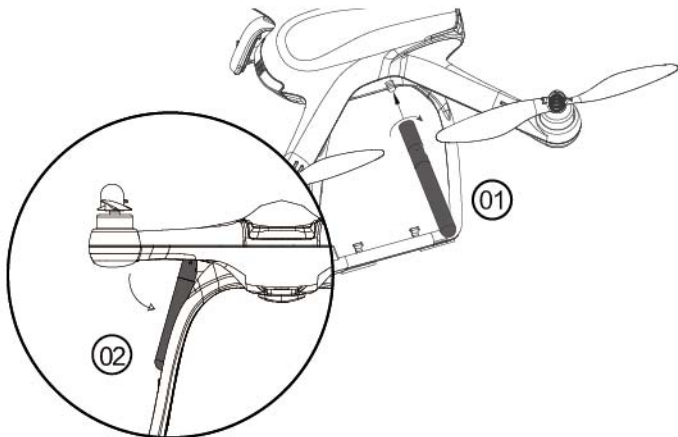

5 INSTALL THE LEATHER COVER AND SUN-SHADE HOOD

The leather cover will protect the H7000 transmitter, and the Sun-shade hood can shield sunlight effectively, so users can have a good view of the images on the tablet. Both are easy to remove/ install.



6 PREPARE THE SMART TRANSMITTER

H7000 is a new kind of smart FPV transmitter. It combines the transmitter with an Android tablet which provides critical information, such as displaying the X4 Pro's location and the flight course. It is equipped with 7" bright 1280 x 720 resolution IPS LCD screen and 1GHz dual-core processor.

 For more information to operate the Transmitter, please refer to "*Ground Station Instruction Manual*".

 Compliance Version: H7000 meets the standard of CE and FCC (Refer to FCC ID)

Operation Mode: The Transmitter has MODE 1 and MODE 2.

MODE 1: The right stick is the Throttle stick.

MODE 2: The left stick is the Throttle stick.

6.1 INTRODUCTION

Below introduction is for MODE 2

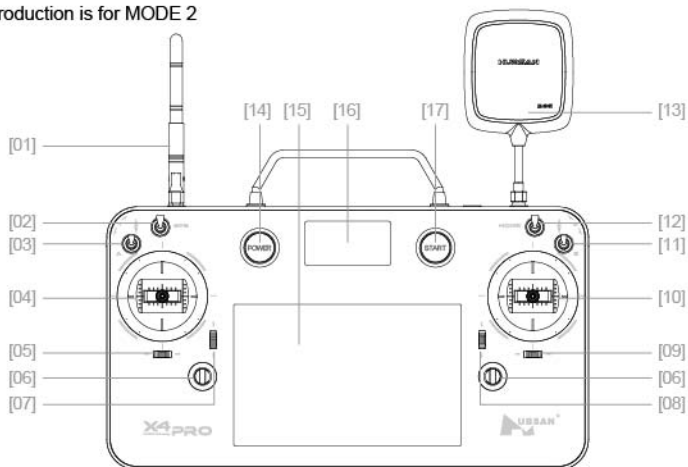

[01] 2.4GHz Antenna

The flight control signal transmitting antenna

[02] GPS Switch (Position-Hold Mode)

Push: Position-Hold Mode

Pull down: Exit the Position-hold Mode

[03] A Switch (Headless Function)

Push: Headless Function

Pull down: Normal Function

[04] Throttle/Rudder Stick

Move the stick forward or backward to make the X4 Pro ascend or descend. Move the stick left or right to rotate the X4 Pro's fuselage left or right.

[05] Rudder Trim

Rudder trim adjusts for drift of left and right rotation or yaw.

[06] Hook

For hanging the transmitter and fixing the sunshield.

[07] Throttle Trim/ Elevator Trim (Mode 1)

Throttle trim normally left at neutral. Holding down the trim for a few seconds will turn LEDs on/ off. Elevator trim adjusts for forward and backward drift

[08] Elevator Trim /Throttle Trim (Mode 1)

Elevator trim adjusts for forward and backward drift. Holding down the Throttle trim for a few seconds will turn LEDs on/ off.

[09] Aileron Trim

Aileron trim adjusts for left and right drift.

[10] Elevator/Aileron Stick

Move the stick forward or backward to make the X4 Pro fly forward or backward. Move the stick left or right to make the X4 Pro fly left or right.

[11] B Switch (Flight Course)

Push: Enter the flight course.

Pull down: Exit the flight course.

[12] HOME Switch (RTH Function)

Push: Enter the RTH function.

Pull down: Exit the RTH function.

[13] 5.8GHz Antenna

Video and image signal transmitting antenna.

[14] POWER Button

Power on/off the transmitter.

[15] Android System LCD Screen

Display waypoints, video image and so on.

[16] Transmitter OLED Screen

Display the Transmitter values.

[17] START Button

Press this button with the power button at the same time. The transmitter will bind to the X4 Pro and relieve the binding. If you just press this button, it will start/ stop the motors.

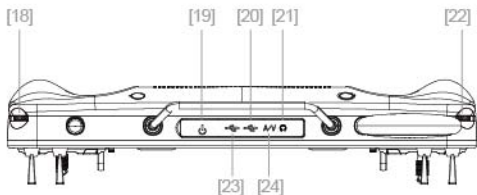

- | | |
|--|--|
| [18] T1 Rotary Switch
Control the gimbal mode | [22] T2 Rotary Switch
Control the pitch rotation of the gimbal. |
| [19] Android System Power Button | [23] Transmitter USB Connector |
| [20] Android System USB Connector | [24] Video Glasses Connector |
| [21] Earphone Socket | |

6.2 THE INSTALLATION OF TRANSMITTER BATTERY

The H7000 Transmitter is equipped with a 7.4V, 2 cell, 5400mAh rechargeable Li-Po battery. Install the Li-Po battery before using.

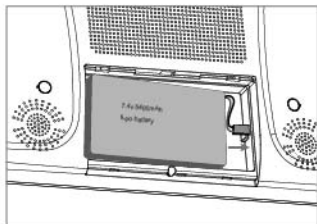

- (1) Remove the battery cover by pressing it down where the mark indicates.
- (2) Connect the battery with the connector of the battery compartment on the right side, and put the battery into the middle of the battery compartment.
- (3) Push the battery cover up and make sure it sticks tightly in place.

- ⊗ ● The battery connector has reverse polarity protection. If the connector will not plug into the interface, you have inserted it wrong. Do not try to force it.
 - If the battery cover does not stick tightly in place, please check to see that the battery is in the middle position.
-
- ⚠ ● Every time before using the battery, please make sure that it has a full charge. If the voltage is too low, the transmitter alarm will sound. Please charge immediately.
 - Please use the correct Micro-USB cable to charge.
 - If the transmitter remains idle for a week or more, please fully charge before using.

6.3 START THE TRANSMITTER.

- (1) Pull down the Switch A, GPS, Home, B into the lower position.
- (2) Hold down the POWER button for a few seconds. The transmitter will power on.
- (3) There is a tone once the transmitter is powered on, the OLED display will be on and displaying the current parameters, and the POWER button will light up.



6.4 METHOD TO BIND THE TRANSMITTER AND X4 PRO

H7000 Transmitter need to bind with the X4 Pro before flight. If binding is required the OLED will show "Data Link Lost", indicating the X4 Pro and the transmitter are not binding. You will need to rebind if you change the transmitter or the X4 Pro.

METHOD OF BINDING

Press both POWER button and START button until the OLED displays "System initialize". Power on the X4 Pro when the OLED displays "Bind to Plane". The binding will be finished in 3 seconds. If binding failed, you need to repower the transmitter and the X4 Pro to try again.

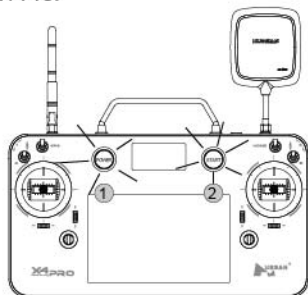

6.5 INTRODUCTION OF THE LCD INTERFACE FUNCTION

[X4 Pro Battery]	BAT	65%	TIME	00:19	[Time]
[TX Power]	TX	35%	DIST	0m	[Distance between X4 Pro and TX]
[TX signal]	RF	88%	ALT	+ 3m	[Altitude]
[GPS Signal]	GPS	0	DIR	NE	[Direction]
[Altitude Hold]	ALT	Hold	Headless		
[TX Low Battery Alarm]	Low Battery TX				

H7000 is a new kind of smart FPV transmitter based on the Android System. For more information to operate the transmitter, please refer to "Ground Station Instruction Manual."

6.6 ANTENNA SIGNAL INSTRUCTION

The live video distance is around 1000 meters. In order to gain the furthest communication distance, make sure the transmitter's antenna is pointed vertically with no obstacles between it and the X4 Pro when in flight. Keep the antenna vertical and always point the signal surface (the logo side) towards the X4 Pro video signal antenna.

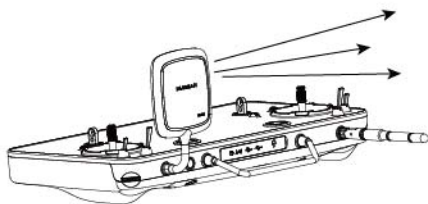

Bend the transmitter antenna vertically, and keep the signal surface pointed towards the X4 Pro video signal antenna. Ensure there are no obstacles between the two, or the X4 Pro will lose the control signal.

PREPARATION FOR FLYING

When assembly is finished, it is best to do some practice or receive training before flying the X4 Pro. Flight simulators are great practice tools and there are many experienced pilots who will be more than happy to show you how to fly. Please choose a safe, suitable environment to fly your X4 Pro.

THE FLIGHT ENVIRONMENT FOR X4 PRO

- (1) Fly the X4 Pro in a large open area. The GPS signal may become weaker and the position hold and RTH function may not be reliable when the X4 Pro flies around trees and buildings.
- (2) Do not fly the X4 Pro in bad weather such as strong wind, heavy snow, rain and foggy conditions.
- (3) When flying the X4 Pro stay away from barriers, people, power cables, trees, and other obstructions.
- (4) Do not fly the X4 Pro near radio towers.
- (5) Magnetic interference will prevent many of the X4 Pro's features from operating at the North and South Poles.
- (6) Do not fly the X4 Pro in any forbidden areas based on your country's laws and regulations.

CHECK BEFORE FLYING

- (1) Make sure the batteries for Transmitter, X4 Pro, parachute, and camera are fully charged before takeoff.
- (2) Make sure the propellers are tight, not damaged, and installed correctly.
- (3) Check that gimbal vibration is minimized and that installation is correct.
- (4) If using a parachute, check if the plug of the parachute is in or out and make sure the battery for the parachute is fully charged.
- (5) If you intend to shoot video or take photos, make sure that the memory card is installed and has sufficient memory remaining for your purposes.
- (6) Test the function of the camera and gimbal before takeoff.
- (7) Check to make sure all motors are working properly before takeoff.

1.COMPASS CALIBRATION

After the X4 Pro power is on, the blue LED of the X4 Pro will blink in a rotating pattern. Put the X4 Pro on a level surface and do not move it. The transmitter display will show "Check Compass", indicating that the X4 Pro is checking the compass. Keep the X4 Pro on a level surface and slowly rotate it until the "Check Compass" disappears.

If the X4 Pro senses abnormalities in the compass sensor, it will enter compass calibration mode. The transmitter screen will show "CAL compass 1"—spin the X4 Pro horizontally until the LCD screen switches to "CAL compass 2", then vertically spin the X4 Pro until "CAL compass 2" disappears. The compass will now be properly calibrated.

You can also follow the below method to calibrate the compass using GPS Switch.

-
- ⊗ Do not calibrate the compass in areas of a strong magnetic field.
 - Do not have keys, magnets, or mobile phones on you while calibrating the compass.
 - Avoid large masses of metal while calibrating the compass.
-

1.1 CALIBRATION

Method of calibration: Hold the Throttle Stick full down, quickly move the GPS Switch until the OLED shows "CAL compass 1", levelly spin the X4 Pro until the OLED shows "CAL compass 2", then vertically spin the X4 Pro until the "CAL compass 2" disappears, indicating a successful calibration.

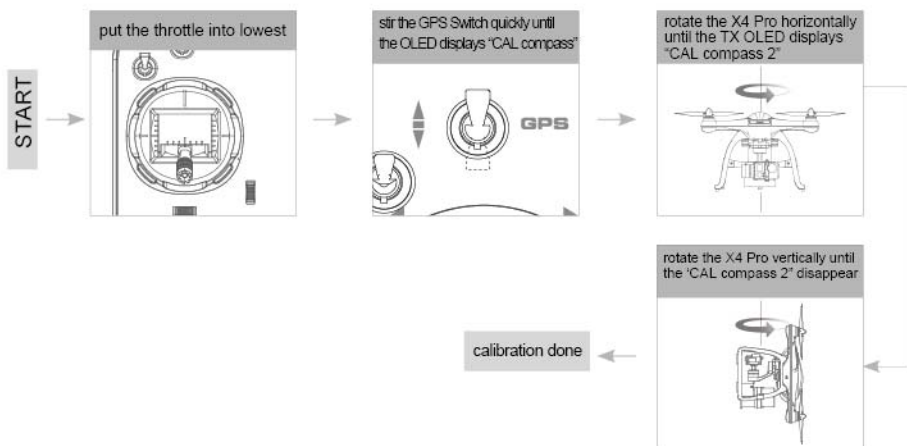

1.2 CHECK GPS CONDITION

Fly the X4 Pro after the GPS value changes to 6 or above for proper position hold and RTH function.

2. START/ STOP THE MOTORS

Start the motors

Method 1: Pull the two sticks as the picture shows. Release them after the motors start.

Method 2: Press the START button for one second. The OLED display will indicate the status of the X4 Pro.

Stop the motors

Method 1: Pull the two sticks again as in the picture. Release them after the motors stop.

Method 2: Press the START button for one second. The motors will stop.

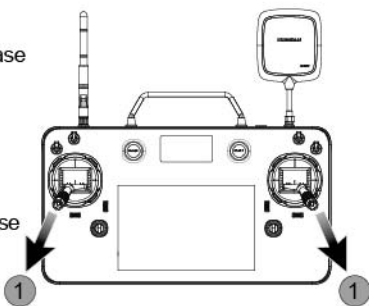



⊘ Do not stop the motors during the flight or it will crash.



- ☀ • Move the sticks as neatly as you can. Release the sticks after the motors start or stop.
- Pull the throttle to the lowest position gently. The throttle stick will be locked. The X4 Pro will descend slowly. Move the throttle stick upward to unlock the throttle.

3 BASIC FLIGHT

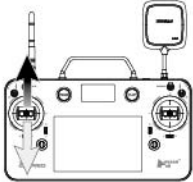
The operation mode for the transmitter is Mode 1 or Mode 2. The manual will use Mode 2 as an example to illustrate the transmitter's operation.

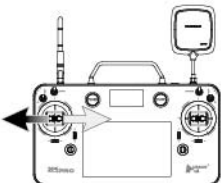
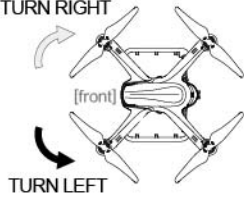
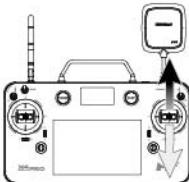
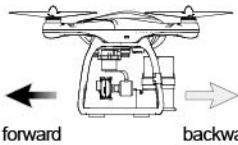
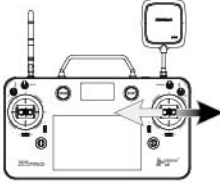
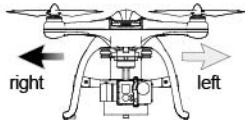
- The stick return to the center: The transmitter's stick is in the center.
- Stick's rudder offset: The offset of the transmitter sticks from the center.

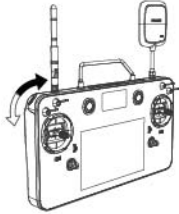
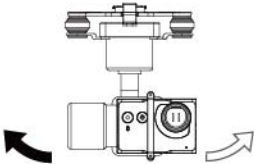
Transmitter (Model 2)	X4 Pro	Control Ways
		<p>The throttle stick controls the ascent and descent of the X4 Pro. The X4 Pro will ascend when the sticks are moved up, descend when the stick is moved down, and remain unchanged when the stick is centered.</p> <p>Move the throttle stick above the center position to take off. (Move the stick gradually to prevent the X4 from ascending too quickly.)</p>
		<p>The rudder stick controls the facing direction of the X4 Pro.</p> <p>The X4 Pro will rotate counterclockwise when you move the stick to the left and clockwise when you move the stick to the right. The rotation angle is zero and the X4 Pro doesn't rotate when the stick is centered. A harder push in either direction will cause the X4 to rotate faster in the corresponding direction.</p>
		<p>The elevator stick moves the X4 Pro forward and backward. Move the stick forward, the X4 Pro will tilt and fly forward. Move the stick backward, the X4 Pro will tilt and fly backward. At center stick the aircraft should hold position.</p> <p>The degree of stick movement corresponds to the degree of tilt and flying speed.</p>
		<p>The aileron stick controls left and right flight. Moving the stick left makes the X4 Pro tilt and fly left. Moving the stick right makes the X4 Pro tilt and fly right. The X4 Pro should be horizontal and unmoving at center stick.</p> <p>The flight speed and tilt angle are linked to the distance pressed on the sticks.</p>

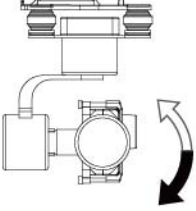
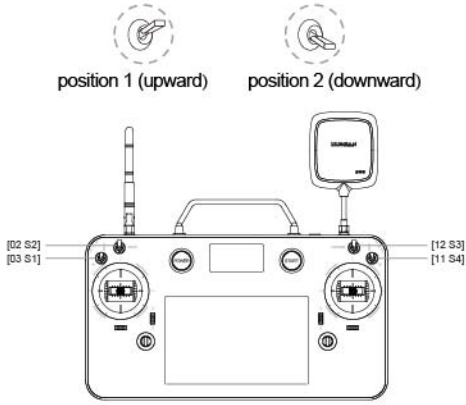
		<p>Slip the T1 Rotary Switch counter-clockwise into the bottom. The gimbal YAW then follows the X4 Pro's YAW when it rotates. The T2 Rotary Switch can control the gimbal's pitch rotation.</p> <p>Slip the T1 Rotary Switch into the middle. The gimbal is now in Locked mode and the gimbal YAW does not rotate with the X4 Pro. The T2 Rotary Switch can control the gimbal's pitch rotation.</p> <p>Slip the T1 Rotary Switch clockwise into the bottom. The gimbal is now in default mode and returns to level. The T2 Rotary Switch cannot control the gimbal's pitch rotation.</p>
		<p>T2 Rotary Switch controls the pitch rotation of the gimbal (only effective when the gimbal in followed mode and locked mode).</p> <p>Slip the T2 Rotary Switch counter-clockwise, and the gimbal will rotate upward;</p> <p>Slip the T2 Rotary Switch clockwise, and the gimbal will rotate downward;</p> <p>Slip the T2 Rotary Switch into the middle. The gimbal will be in the level position and the transmitter will shake and sound a beep to confirm.</p>
 <p>position 1 (upward) position 2 (downward)</p>		<p>GPS Switch is position-hold function switch. Position-Hold function means the X4 Pro can be fixed in the very position.</p> <p>In position 1 (up), the GPS functions are active.</p> <p>In position 2 (down), the GPS functions are deactivated.</p> <p>A Switch is headless function switch. Headless function means the X4 Pro will fly in the direction the X4 Pro stands in the moment this function starts, regardless of the X4 Pro's heading.</p> <p>Up (position 1) is on.</p> <p>Down (position 2) is off.</p> <p>B Switch is flight course switch. Flight course consists of waypoints set on the map.</p> <p>Up (Position 1) activates the flight course.</p> <p>Down (Position 2) deactivates the flight course.</p> <p>HOME Switch is RTH function Switch. RTH function means return to home function.</p> <p>Up (Position 1) activates the RTH function.</p> <p>Down (Position 2) deactivates the RTH function.</p>

4 SIGNAL LOSS PROTECTION FUNCTION

If the X4 Pro loses transmitter signal, the flight control system will take control of the model and either land it or return it to the 'home' position and land automatically. This helps prevent operators from losing or crashing their X4 Pro.

 **DEPARTURE POINT:** When the X4 Pro enters the safe flight state with 6 or more GPS satellites, the X4 Pro will record the position as departure point.

4.1 CONDITIONS WHICH ACTIVATE THE SIGNAL LOSS PROTECTION MODE.

- (1) Transmitter power is off.
- (2) The flight distance is beyond the effective distance of the transmitter's signal transmission.
- (3) There are obstacles between the X4 Pro and the transmitter.
- (4) The transmitter's signal was interrupted by some other strong electronic interference.

4.2 EXITING RTH MODE

Pull down the RTH function switch (Home switch) and the flight course switch (B switch). The X4 Pro will exit the RTH Mode.

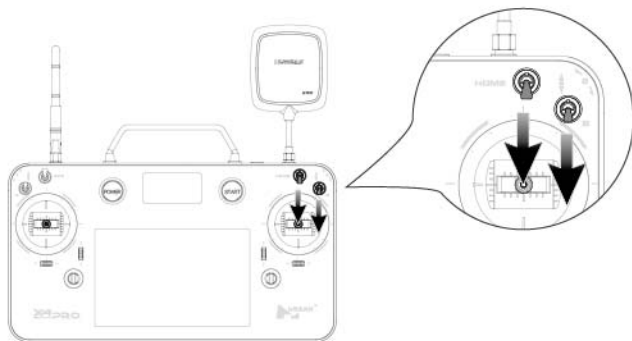

- ⊘ To ensure that the X4 Pro can return safely to its home point when signal is lost, fly the X4 Pro in the safe flight state.
- If the quantity of GPS stars drops below six for more than 20 seconds while the X4 Pro is returning to home, the X4 Pro will descend automatically.
- The X4 Pro will not avoid obstacles automatically while in RTH mode. You must set the height value to avoid obstacles in the X4's path.

5 INTELLIGENT BATTERY ALARM FUNCTION

When the voltage of the X4 Pro battery drops below 10.8V, the quad will begin to slowly descend. At this point, the quad will still ascend when throttle is increased, but you should land the X4 Pro as soon as possible.

X4 Pro Battery	BAT 65%	TIME 00:19
	TX 35%	DIST 0m
Transmitter Low battery Alarm	RF 88%	ALT + 3m
	GPS 0	DIR NE
	ALT Hold	Headless
	Low Battery TX	

TROUBLESHOOTING

1. The motor doesn't work.

Recalibrate the transmitter.

MODE 1 transmitter

Push the left joystick to the top on the left, and the right joystick to the top on the right. Keep them in this position and then turn on the transmitter. The LCD screen will show "Calibrate Stick". Move the joysticks in a circling motion about three times and then release and press any trim to save stick calibration.

MODE 2 transmitter

Push the two joysticks to the top on the left and keep them in this position, and then turn on the transmitter. The LCD screen will show "Calibrate Stick". Move the joysticks in a circling motion about 3 times, and then release the joystick and press any trim to save and exit.

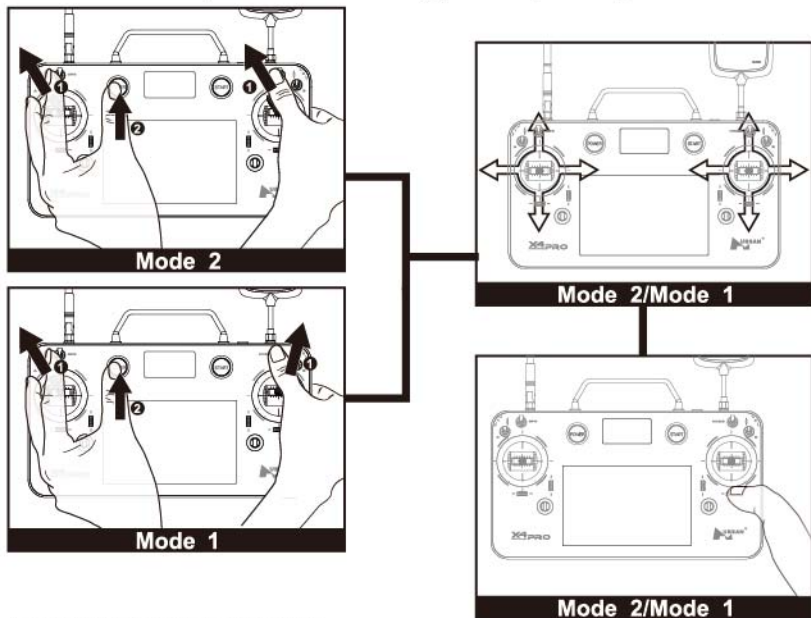

2. The X4 Pro drifts during flight.

When you turn on the X4 Pro, keep it steady for 10 seconds to calibrate the sensors.

3. The GPS position hold is not good.

Please check your surroundings carefully for things that might interfere with the GPS signal. If the area is clear, recalibrate the compass sensor.

4. The Transmitter sounds "Beep, Beep"

Please check the power of the battery. Stop flying and charge the battery.

5. The X4 Pro will sound "Beep, Beep" when the power is on.

Update the flight control program again.

6. The transmitter loses control and the X4 Pro cannot be found.

Push Home Switch upward, and the RTH function starts. When the transmitter locates the X4 Pro and receives the signal, if users want to manually operate the X4 Pro, the Home Switch and the Flight course Switch (SB) need to be pulled downward.

7. No videos on the screen.

Check the camer. If the camera's connecting wires are loose or its LiPo battery has low power, no videos will be seen.

8. Gimbal does not work after moving the rotary switches.

Please check the wire connecting the gimbal. After a crash, it may loosen.

FCC INFORMATION

This equipment has been tested and found to comply with the limits for a Class B digital device, pursuant to Part 15 of the FCC Rules. These limits are designed to provide reasonable protection against harmful interference in a residential installation. This equipment generates, uses, and can radiate radio frequency energy and, if not installed and used in accordance with the instructions, may cause harmful interference to radio communications. However, there is no guarantee that interference will not occur in a particular installation. If this equipment does cause harmful interference to radio or television reception, which can be determined by turning the equipment off and on, the user is encouraged to try to correct the interference by one or more of the following measures:

- Reorient or relocate the receiving antenna.
- Increase the separation between the equipment and receiver.
- Connect the equipment into an outlet on a circuit different from that to which the receiver is connected.
- Consult the local dealer or an experienced radio/TV technician for help.

Changes or modifications not expressly approved by the party responsible for compliance could void the user's authority to operate the equipment.

This device complies with Part 15 of the FCC Rules. Operation is subject to the following two conditions: (1) this device may not cause harmful interference, and (2) this device must accept any interference received, including interference that may cause undesired operation.

Electrical and electronic equipment that are supplied with batteries (including internal batteries)

WEEE Directive & Product Disposal

At the end of its serviceable life, this product should not be treated as household or general waste. It should be handed over to the applicable collection point for the recycling of electrical and electronic equipment, or returned to the supplier for disposal.

Internal / Supplied Batteries.

This symbol on the battery indicates that the battery is to be collected separately.

This battery is designed for separate collection at an appropriate collection point.



User manual is subject to change without prior notice.

Download the latest user manual from

WWW.HUBSAN.COM

