

RIMFIRE™

42MM BRUSHLESS OUTRUNNER MOTOR



ElectriFly™
by Great Planes

Congratulations, you have just purchased one of the RimFire 42mm power system components. All the components are sold separately to allow you to customize your power system to your airplane. The components needed to assemble your complete RimFire 42mm power system are: RimFire 42mm motor, propeller, propeller adapter and brushless speed control. This instruction sheet explains how to determine what you will need and how to assemble each component.

1 MOTOR

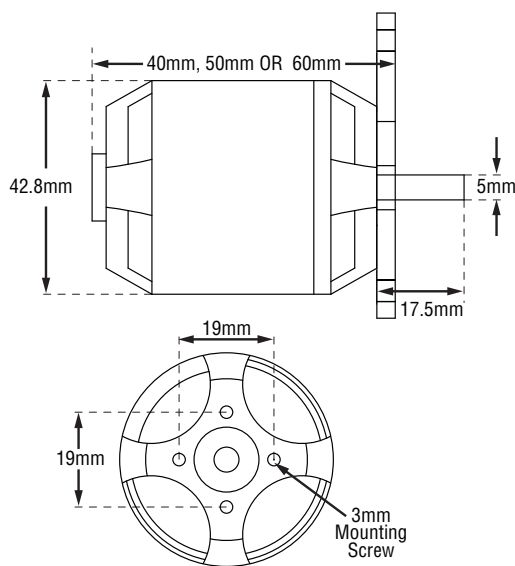

The RimFire motors are labeled to provide the most information at a glance. For example: The RimFire .32 (42-50-800) is 42mm in diameter, 50mm long and has a kV (rpm-per-volt) of 800.

RimFire .25 (42-40-1000) (GPMG4675)

Motor Output Shaft Diameter and Length: 5x17.5mm [0.2"x0.7"]
Weight: 125g [4.4oz]
Input Voltage: 11.1 – 14.8V
Max Surge Current: 50A
Max Surge Power: 740W

RimFire .32 (42-50-800) (GPMG4000)

Motor Output Shaft Diameter and Length: 5x17.5mm [0.2"x0.7"]
Weight: 198g [7oz]
Input Voltage: 11.1 – 14.8V
Max Surge Current: 80A
Max Surge Power: 1480W

RimFire .46 (42-60-800) (GPMG4725)

Motor Output Shaft Diameter and Length: 5x17.5mm [0.2"x0.7"]
Weight: 268g [9.5oz]
Input Voltage: 18.5 – 22.2V
Max Surge Current: 100A
Max Surge Power: 1850W

RimFire .55 (42-60-480) (GPMG4715)

Motor Output Shaft Diameter and Length: 5x17.5mm [0.2"x0.7"]
Weight: 268g [9.5oz]
Input Voltage: 18.5 – 22.2V
Max Surge Current: 80A
Max Surge Power: 1850W

Understanding Motors

kV (rpm/volt): This is a number that gets thrown around quite a bit when talking electrics and it is important to know what it is. kV is the number of rpm a motor will spin per each volt applied (rpm/volt) under no load.

This means that a motor with a kV of 1000 when connected to a 12V battery will try to spin at 12,000rpm (1000x12) under no load. Likewise a 3500kV motor will try to spin at 42,000rpm (3500x12) under no load.

When a propeller is attached to the motor, the motor will try to spin the prop at the rated kV. Depending on the diameter and pitch of the propeller (the larger the diameter or higher the pitch, the harder it is to spin), the motor's current draw can be increased or decreased. There are meters available from your hobby dealer that measure current and voltage.

Because every motor has a maximum current it can take based on its design and cooling ability, the maximum size of propeller that can be used with each motor can be determined. If the propeller is too large, the motor will spin at a much lower rpm than its rated kV, causing it to draw a lot of current and overheat. If the propeller/fan is too small, it will require little effort (current) to turn the prop at the rated kV.

Ideally the motor should be matched with a propeller that causes the motor to draw 80-100% of its rated maximum constant current. Once a power system is set up, it can be fine-tuned by adjusting the propeller size and measuring the amount of current the motor is drawing.

Please note that the kV of a motor does not change with voltage, but if a higher voltage is applied to the motor, it will try to spin the same propeller at a higher rpm. This will cause the motor to draw more current and possibly exceed the maximum rated current of the motor. So, if a battery with lower voltage is replaced with one with a higher voltage, it is recommended that a smaller propeller be used to keep the current in check. If a higher voltage battery is replaced by a lower voltage battery, the size of the propeller can be increased to keep the motor at its rated current.

Another possibility to fine tune the power system's performance is to use another motor with higher kV to increase the current or a lower kV to lower the current.

2 ELECTRONIC SPEED CONTROL (ESC)



An ESC is basically the device that controls your motor through your radio system. Never run any RimFire motors with a brushed ESC. It will not work and you may damage both the motor and the ESC. Always use a brushless ESC. ElectriFly offers the **Silver Series SS-45, SS-60 and SS-80** Brushless ESCs (**GPM11840, GPM11850 and GPM11860**) that work well with the RimFire 42mm motors.

The SS-45 and SS-60 ESCs come with 4mm female bullet connectors that plug directly into the 4mm male connectors installed on the RimFire 42mm motors, so no soldering is required. The SS-80 comes with 6mm female bullet connectors and requires an adapter (GPM11319). Also, these ESCs come with a Deans® Ultra Plug® battery connector that matches the connectors that are found on most batteries that it will use.

3 BRUSHLESS MEDIUM MOTOR MOUNT

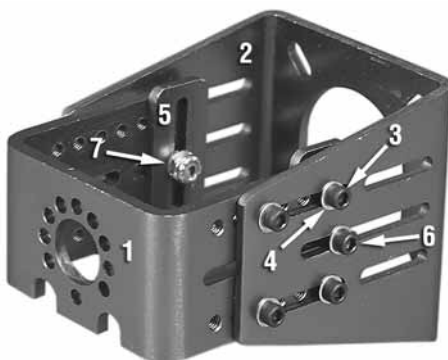

1. Front Plate (1)
2. Back Plate (1)
3. 4-40x1/4" SHC Screw (8)
4. #4 Flat Washer (10)
5. Motor Bracket (1, not used)
6. 4-40x1/2" SHC Screw (2, not used)
7. 4-40 Lock Nut (2, not used)

The ElectriFly Brushless Medium Motor Mount combines ease of installation with the adjustability to fit most motor applications. The Medium Motor Mount is designed to fit the bolt pattern of the Great Planes® .20-.48 and .40-.70 Nylon Engine Mount. This easily allows the conversion of a glow powered plane to electric powered.

4 PROPELLERS



There is a wide selection of propellers available for electric use. The RimFire 42mm motors use high performance electric props such as the APC E-series props. The larger the propeller used, the more current your motor will draw. The smaller the propeller, the less current the motor will draw.

Shown are a few of the recommended electric props. Due to the large range of propellers and the constant addition of new sizes, visit our web sites at www.electrifly.com and www.greatplanes.com for the most up-to-date listing of electric type props.

APCQ4120	10x5 Electric	APCQ3080	13x8 Electric
APCQ4123	10x7 Electric	APCQ4140	13x10 Electric
APCQ1055	11x5.5 Electric	APCQ4145	14x7 Electric
APCQ4128	11x7 Electric	APCQ1409	14x10 Electric
APCQ4129	11x8 Electric	APCQ4016	16x10 Electric
APCQ4131	11x8.5 Electric	APCQ4019	17x10 Electric
APCQ4130	12x6 Electric	APCQ4021	18x8 Electric
APCQ3065	13x6.5 Electric	APCQ4028	20x10 Electric

5 PROPELLER ADAPTERS

The RimFire 42mm motor comes with a prop adapter that mounts directly to the motor case. If the RimFire 42mm motor needs to be mounted so that the prop is mounted on the motor shaft, the motor requires a 5mm prop adapter collet type or set screw type.



GPMQ4966 5mm Collet Type



GPMQ4939 5mm Set Screw Type

6 LIPO BATTERIES



Number of Cells

Cells can be connected in series or in parallel. Usually batteries are labeled by their number of cells, such as a 3-cell LiPo. This means the cells are connected in SERIES (S). Arranging batteries in series gives you more power (higher voltage). Each LiPo battery has 3.7V, so a 3-cell LiPo battery has 3.7x3 = 11.1V

If you need a higher voltage than what is available in the LiPo battery line, you will need to connect two battery packs together in series. If you need a battery voltage of 14.8V you can use the **Series Y-Connector (GPM11343)** to connect two 7.4V batteries together.

If a battery is arranged in PARALLEL it might be labeled as (P). Arranging the batteries in parallel will give you more duration (more capacity).

All LiPo batteries have a rated discharge that must not be exceeded or the battery will be damaged. They may say 20C max. discharge rate or 25C max. discharge rate. This means that the discharge rate (current draw of the motor) must not be more than 20 or 25 (20C or 25C) times the capacity of the battery. The capacity is expressed in milliamp hours (2200mAh). It can also be expressed in amp hours (2.2Ah).

A LiPo battery with a capacity of 2200mAh with a 25C discharge rate can be discharged at 55 amps, 2.2Ah x 25C = 55 amps. If the power system draws more than 55 amps, the batteries will have to be connected in parallel to increase the capacity. Two 2200mAh batteries in parallel have a capacity of 4400mAh or 4.4Ah x 25C = 110 amp discharge rate.

ElectriFly offers a full line of LiPo batteries. Airplanes that use the RimFire 42mm motors will typically use batteries with a capacity of 1800 to 3350mAh, with the higher capacity batteries delivering more flying time but also being heavier. All of the batteries have connectors that fit the recommended ESCs.

Due to the constantly changing battery technology, check out the ElectriFly web site at www.electrifly.com for the most up-to-date listing of the ElectriFly battery line.

Stock #	Voltage	Capacity	Weight	# of Cells	Discharge
GPMP0514	7.4V	1800mAh	3.6oz (102g)	2	25C
GPMP0515	11.1V	1800mAh	5.2oz (148g)	3	25C
GPMP0519	7.4V	2200mAh	4.4oz (125g)	2	25C
GPMP0520	11.1V	2200mAh	6.3oz (179g)	3	25C
GPMP0521	14.8V	2200mAh	8.2oz (233g)	4	25C
GPMP0540	7.4V	3350mAh	6.6oz (188g)	2	25C
GPMP0541	11.1V	3350mAh	9.7oz (275g)	3	25C
GPMP0542	14.8V	3350mAh	12.2oz (347g)	4	25C
GPMP0543	18.5V	3350mAh	15.3oz (435g)	5	25C

7 DETERMINE WHAT YOU NEED TO BUILD YOUR POWER SYSTEM

Now that you have one component for your power system, there are several different ways to select the rest. In time, experience will help you to determine what works best for you, but an easy way to determine what you need now is the following.

Procedure #1: If you know the size of the propeller you want to turn and the rpm, then:

- ❑ 1. Find the combination that delivers the closest performance to what you want (refer to the Electrify web site for typical combinations), or refer to the airplane manufacturer's recommendations.
- ❑ 2. Note the recommended battery voltage.
- ❑ 3. Determine the battery capacity needed based on the current draw of your system and your desired flight time.
- ❑ 4. Determine the ESC you need based on the system current draw. See the ESC section.

Procedure #2: If you know the approximate weight of your airplane, including the motor and battery, and the performance you want from it, answer the questions below to determine the correct power system for your plane. You may need to make more than one calculation using different motors and battery combinations. See the battery section for some of the battery weights for the suggested batteries.

- ❑ 1. Perform the following calculation to determine the wattage required:
 - If you expect trainer-like performance, then multiply **75 x Airplane Weight (lbs)**
 - If you expect aerobatic or high speed-like performance, then multiply **100 x Airplane Weight (lbs)**
 - If you expect 3D or extreme performance, multiply **150 x Airplane Weight (lbs)**
- ❑ 2. The number you get is the minimum wattage you will need for your plane to perform as you wish. $Watts = current (A) \times voltage (V)$. Using suggested power system combinations as reference, determine what combination gives you the performance you want based on wattage and maximum propeller size that will fit on the plane.
- ❑ 3. Choose a battery voltage within the recommended range of the motor.
- ❑ 4. Determine the battery capacity needed based on the current draw of your system and your desired flight time.
- ❑ 5. Determine the ESC you need based on the system current draw.

In addition to these two procedures, you can also visit the Great Planes Electrify web site for descriptions of the power systems recommended for our line of electric and glow airplanes as well as more detailed explanation on the subject.

Recommended Setups:

- RimFire .25:** 3S Battery, 11x8.5 Electric Prop
- RimFire .32:** 4S Battery, 13x8 Electric Prop
- RimFire .46:** 6S Battery, 11x5.5 Electric Prop
- RimFire .55:** 6S Battery, 13x10 Electric Prop

8 ASSEMBLE YOUR POWER SYSTEM

Once the required RimFire motor has been determined, it needs to be installed on the plane. To determine the best mounting system, the distance from the firewall to the front of the prop adapter first needs to be determined.

It can be mounted directly to the firewall using the RimFire aluminum mounting plate (included with the motor), or an Electrify Medium Motor Mount (GPMG1255). Both mounting systems are direct replacements for the Great Planes® .20-.48 and .40-.70 nylon engine mounts.

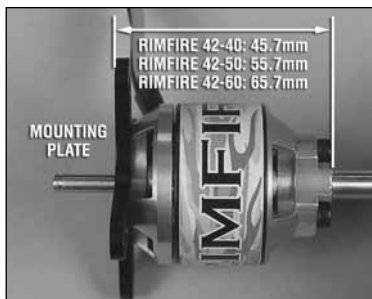

RimFire 42mm Aluminum Mounting Plate Template

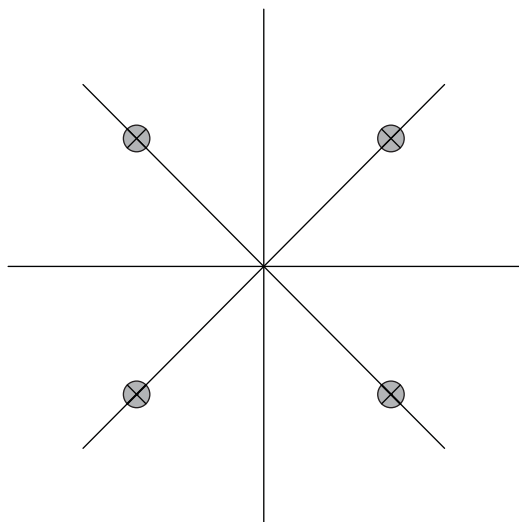

Check the airplane instruction manual for the correct distance. These pictures show the distances from the firewall to the front of the prop adapter using the different mounting systems.



If you are replacing a glow engine with an electric motor system, remove the nylon engine mount and replace it with the Medium Motor Mount or RimFire mounting plate, using the same bolts to attach it to the firewall. If the firewall has not been drilled for an engine mount and blind nuts, use the mounting template on the header card to locate the mounting holes. Drill the four mounting holes and install 6-32 blind nuts from the back of the firewall.



MOUNTING PLATE INSTALLATION

If attaching the motor to the firewall using the adjustable motor mount, skip to the **Medium Motor Mount Installation**.

Note: Apply a drop of **Threadlocker (GPMR6060)** to all bolts and screws used to install the motor on the plane.

Attach the backplate to the motor using four 3x8mm flat head machine screws and threadlocking compound.



Attach the Backplate of the motor mount to the firewall using four 6-32 machine screws and four #6 flat washers. Apply a drop of Great Planes Threadlocker to the screws before installing them. Mount the aluminum prop adapter to the motor case using four 3x7mm SHC screws. Apply a drop of threadlocker to the threads of each bolt.

MEDIUM MOTOR MOUNT INSTALLATION

Note: Apply a drop of **Threadlocker (GPMR6060)** to all bolts and screws used to install the motor on the plane.

Attach the backplate of the motor mount to the firewall using four 6-32 machine screws and four #6 flat washers.



Remove the c-clip from the motor shaft. Mount the RimFire motor to the motor mount front plate (front or back) using four 3mm machine screws.



Install the collet or set screw prop adapter on the motor shaft or the aluminum prop adapter on the motor case. The RimFire 42mm motors use the 5mm prop adapter (GPMQ4966 Collet Type or GPMQ4939 Set Screw Type).

ALUMINUM PROP ADAPTER INCLUDED WITH MOTOR

Mount the aluminum prop adapter to the motor case using four 3x7mm SHC screws and threadlocking compound.



COLLET TYPE PROP ADAPTER INSTALLATION

Slide the prop shaft over the output shaft of the gear drive or motor. Next slide the prop shaft retainer over the prop shaft. Note that the hole through the retainer is tapered. Make sure that the side with the larger diameter hole is installed first. Install the spinner backplate (if used, **not included**), the prop, prop washer and then the prop nut. Tighten the prop nut against the prop. This will cause the tapered hole in the prop shaft retainer to squeeze the prop shaft around the output shaft. Carefully pull on the prop to make sure it is securely attached to the output shaft of the gear drive.

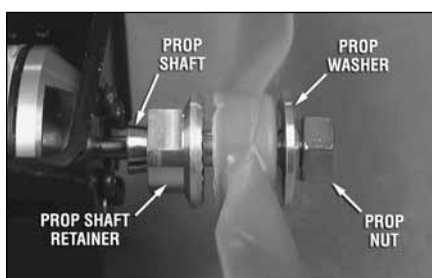

SET SCREW TYPE PROP ADAPTER INSTALLATION

Slide the prop adapter over the output shaft of the gear drive or motor. Apply a drop of Great Planes **Threadlocker (GPMR6060)** to the set screws and install them in the prop adapter, tightening them against the motor shaft.

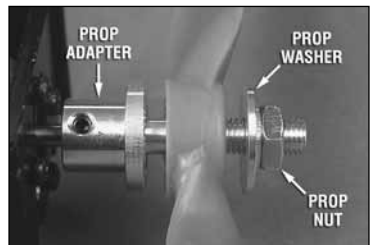

Position the motor/front plate assembly between the backplate. Measure the distance from the firewall to the front of the prop adapter. Attach the front plate of the motor mount to the back plate using the eight 6-32x1/2" SHC screws, eight #6 flat washers and four aluminum screw plates, spaced out as far as possible.

Note: Once the motor is mounted in position, the collet type prop adapter can be removed to allow the cowl to be mounted. This adapter is easily installed with the cowl already installed.

9 INSTALL THE BRUSHLESS ESC

Mount your ESC in the desired location. Always make sure that the ESC is positioned so that it gets some cooling air flowing over it. Use the instructions included with the ESC to correctly connect the ESC.

10 RIMFIRE MOTOR MAINTENANCE

RimFire brushless motors require virtually no maintenance. There are no brushes to wear out and replace. The precision bearings have a very long service life and should last a very long time. The internal parts of the motor should not require any cleaning. The only thing that needs to be checked is to make sure all the screws and set screws remain tight.

11 IMPORTANT PRECAUTIONS

- Once the battery is connected to the ESC, stay clear of the motor and prop.
- DO NOT apply an input voltage that exceeds the maximum specification of each motor.
- DO NOT apply currents to the motor that exceed the maximum specifications of each motor.
- DO NOT allow the input connectors to accidentally touch each other while power is applied to the motor. Make sure all input connections are insulated electrically.
- DO NOT allow water or moisture to enter the motor, as it can cause permanent damage to the motor and possibly short out the attached ESC.
- DO NOT cut the coated wires from the motor. If you must remove the bullet connectors, unsolder them.
- Allow the motor to cool after each flight.
- The motor shaft of the motor will rotate at very high rpm. DO NOT attempt to touch the shaft while it is rotating. If setting up the motor/ESC on the workbench, make sure the motor is securely attached and that nothing is attached to the motor shaft BEFORE applying power.
- Never attempt to use a damaged motor (having mechanical or electrical defects).

Electrify carries a complete line of Ammo (inrunner style) and RimFire (outrunner style) brushless motors, gear drives, motor mounts, prop adapters and speed controls. For a complete list of these products, check out our web site at:

www.greatplanes.com
www.electrify.com

or visit your nearest hobby shop that carries the full line of Great Planes and Electrify products.

12 REPLACEMENT PARTS

- GPM3114** 4mm Gold Plated Bullet Connectors - Male (3)
- GPM3115** 4mm Gold Plated Bullet Connectors - Female (3)
- GPMQ4906** RimFire Prop Adapter for 42mm Motors
- GPMG1205** RimFire Backplate Motor Mount for 35-42mm Motors
- GPMG1434** C-Clip (10) for 5mm RimFire Motor Shafts
- GPMG1456** Bearings (3) for RimFire 42-xx-xx Motors
- GPMG1412** Replacement Shaft Kit for RimFire 42-40-xx Motors
- GPMG1414** Replacement Shaft Kit for RimFire 42-50-xx Motors
- GPMG1416** Replacement Shaft Kit for RimFire 42-60-xx Motors