

ElectriFly™
by Great Planes®

AMMO

**AMMO 36mm
POWER SYSTEM**



Congratulations, you have just purchased the Ammo 36mm power system components. All the components are sold separately to allow you to customize your power system to your airplane. The components needed to assemble the Ammo 36mm power system are: Ammo 36mm motor, 36mm Large Gear Drive, Large Motor Mount, propeller, propeller adapters and brushless speed control. This instruction sheet explains how to determine what you will need and how to assemble each component.

MOTORS

Model	Stock #
36-30-3200	GPMG5240
36-30-4000	GPMG5245
36-30-5300	GPMG5250
36-40-2250	GPMG5255
36-40-2900	GPMG5260
36-40-3900	GPMG5265
36-50-1500	GPMG5285
36-50-2300	GPMG5290
36-50-3300	GPMG5295
36-56-1200	GPMG5310
36-56-1800	GPMG5315
36-56-2600	GPMG5320
36-88-1280	GPMG5325

The Ammo motors are labeled to provide the most information at a glance. For example: the 36-50-1500kV is 36mm in diameter, 50mm long and has a kV (rpm-per-volt) of 1500 rpm.

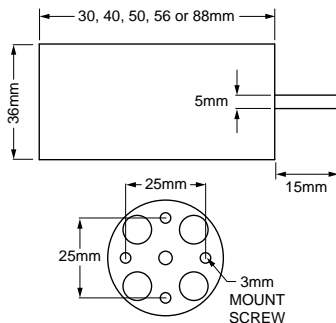

Motor Output Shaft

Diameter x Length: 5x14.5mm [0.2" x 0.58"]

Weight (30mm): 138g [4.8oz.]

Weight (40mm): 185g [6.5oz.]

Weight (50mm): 243g [8.6oz.]

Weight (56mm): 283g [10oz.]

Weight (88mm): 461g [16.3oz.]

BRUSHLESS LARGE MOTOR MOUNT

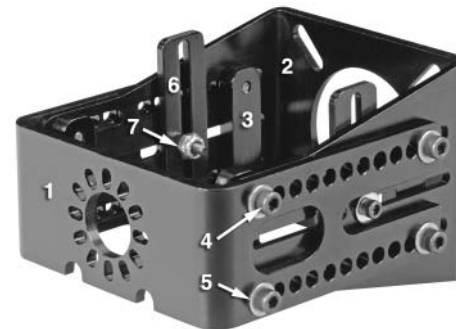

1. Front Plate (1)
2. Back Plate (1)
3. Motor Bracket (1)
4. Screw Plate (4)
5. 6-32x1/2" SHC Screw (8)
6. #6 Flat Washer (8)
7. 4-40x1/2" SHC Screw (2)
8. #4 Flat Washer (2)
9. 4-40 Lock Nuts (2)

The ElectriFly Brushless Large Motor Mount combines the ease of installation with the adjustability to fit most motor applications. The Large Motor Mount is designed to fit the bolt pattern of the Great Planes .60-1.20 Nylon Engine Mount. This easily allows the conversion of a glow powered plane to electric powered.

GEARBOX

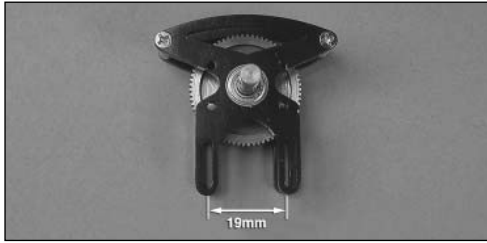

The ElectriFly Ammo motors have high kVs meaning that they like to run at very high rpm. A gear drive is used in order to reduce the rpm allowing a larger, more efficient propeller to be used. Great Planes ElectriFly offers a **36mm Large Gear Drive (GPMG0515)** with several pinions that allow for the following gear ratios:

Spur Gear	GPMG0668	70 tooth
	GPMG0672	90 tooth
Pinion Gear	GPMG0637	14 tooth
	GPMG0643	20 tooth

Low Ratio > 6.4:1, 5:1, 4.5:1, 3.5:1 **<High Ratio.**

If you use a prop that is too small with a gear ratio that is too low, the motor will draw very little current and the prop will turn at too low of an rpm to produce any usable power. The higher the gear ratio, the smaller the prop will need to be and the higher the rpm will be. If the gear ratio is too high for the prop used, the motor will draw excessive current and overheat.

The 36mm Large Gear Drive is designed to fit the Great Planes Large Motor Mount (GPMG1260).

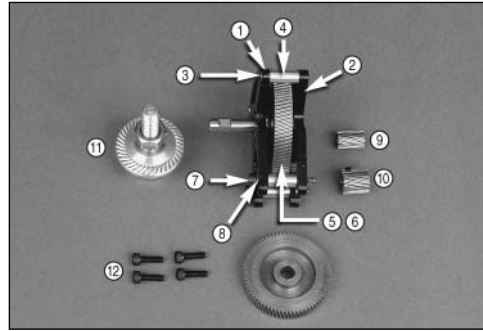

1. Aluminum Front Plate (1)
2. Aluminum Back Plate (1)
3. 2.5x18mm FH Machine Screw (2)
4. 6x11mm Aluminum Spacer (4)
5. 70 Tooth Spur Gear (1)
6. 90 Tooth Spur Gear (1)
7. 3x23mm SHC Screw (2)
8. 3mm Star Washer (2)
9. 14 Tooth Pinion Gear (1)
10. 20 Tooth Pinion Gear (1)
11. 6mm Collet Type Prop Adapter (1)
12. 3x8mm Machine Screw (5)

PROPELLER ADAPTERS

The 36mm Large Gear Drive uses a 6mm prop adapter. If you will be using the 36mm Ammo Motor without a gear drive, it requires a 5mm prop adapter.



GPMQ4939 5mm Set Screw Type
GPMQ4942 6mm Set Screw Type



GPMQ4966 5mm Collet Type
GPMQ4968 6mm Collet Type

PROPELLERS



There is a wide selection of propellers available for electric use. The 36mm Ammo Motors use high performance electric props such as the APC E-series props. The larger the propeller used, the more current your motor will draw. The smaller the propeller, the less current the motor will draw.

Shown are a few of the recommended electric props. Due to the large range of propellers and the constant addition of new sizes, visit our web sites at www.electrifly.com and www.greatplanes.com for the most up-to-date listing of electric type props.

APCQ4110.....	8x4 Electric
APCQ4115.....	8x6 Electric
APCQ4118.....	9x6 Electric
APCQ4120.....	10x5 Electric
APCQ4123.....	10x7 Electric
APCQ4128.....	11x7 Electric
APCQ4129.....	11x8 Electric
APCQ4130.....	12x6 Electric
APCQ4133.....	12x8 Electric
APCQ3065.....	13x6.5 Electric
APCQ3080.....	13x8 Electric
APCQ4145.....	14x7 Electric

BATTERIES: CHEMISTRY

The Ammo Motor/Silver Series ESC combination can use NiMH or LiPo batteries. Typically, NiMH batteries are heavier but much more affordable for the same capacity as LiPo batteries. If you want a very light, high-performance airplane, you might want to use LiPo batteries, but if weight is not a concern, then NiMH batteries might be for you.



BATTERIES: NUMBER OF CELLS

Cells can be connected in series or in parallel. Usually batteries are labeled as 8-cell NiMH or 3-cell LiPo. This means the cells are connected in **SERIES (S)**. Arranging batteries in series gives you more power (higher voltage).

- Each NiMH cell has 1.2V, so an 8-cell NiMH battery has $1.2 \times 8 = 9.6V$
- Each LiPo battery has 3.7V, so a 3-cell LiPo battery has $3.7 \times 3 = 11.1V$

If you need a higher voltage than what is available in the LiPo battery line, you will need to connect two battery packs together in series. If you need a battery voltage of 14.8V you can use the **series Y-connector (GPMM3143)** to connect two 7.4V batteries together.

If a battery is arranged in **PARALLEL** it might be labeled as (P). Arranging the batteries in parallel will give you more duration (more capacity). You can use the **parallel Y-connector (GPMM3142)** to connect two batteries in parallel.

ElectriFly offers a full line of NiMH and LiPo batteries. Airplanes that use the AMMO 36mm motors will typically use batteries with a capacity of 2000 to 5000mAh with the higher capacity batteries delivering more flying time but also being heavier. All of the batteries have connectors that fit the recommended ESCs.

Due to the constantly changing battery technology, check out the ElectricFly web site at www.electrifly.com for the most up-to-date listing of the ElectricFly battery line.

ELECTRONIC SPEED CONTROL (ESC)

An ESC is basically the device that controls your motor through your radio system. Never run any Ammo motors with a brushed ESC. It will not work and you may damage both the motor and the ESC. Always use a brushless ESC. ElectricFly offers Brushless ESCs that will work with the Ammo 36mm motors.



Silver Series 45 (SS-45) ESC (GPMM1840)
for 45A maximum constant current draw.



Silver Series 60 (SS-60) ESC (GPMM1850)
for 60A maximum constant current draw.

Silver Series 80 (SS-80) ESC (GPMM1860)
for 80A maximum constant current draw.

Silver Series 100 (SS-100) ESC (GPMM1870)
for 100A maximum constant current draw.

Silver Series Programming Card (SS-60, 80, 100) (GPMM1895) for programming the SS-60, SS-80, and SS-100 brushless ESC's.

The SS-45 and SS-60 ESCs come with 4mm female bullet connectors that plug directly into the 4mm male connectors installed on the AMMO 36mm motors, so no soldering is required. Also, these ESCs come with a Deans® Ultra Plug™ battery connector that matches the connectors that are found on most batteries that it will use.

DETERMINE WHAT YOU NEED TO BUILD YOUR POWER SYSTEM

Now that you have a component for your power system, there are several different ways to select the rest of the components of your power system. In time, experience will help you to determine what works best for you, but an easy way to determine what you need now is the following.

PROCEDURE #1: If you know the size of the propeller you want to turn and the rpm, then look at the chart included in the packaging and:

- ❑ 1. Find the combination in the motor/prop chart that delivers the closest performance to what you want.
- ❑ 2. Note the gear ratio you need.
- ❑ 3. Note the recommended battery voltage.
- ❑ 4. Determine if you want to use LiPo or NiMH batteries based on the desired ready-to-fly airplane weight. Select the number of cells based on the recommended voltage shown on the chart.
- ❑ 5. Determine the battery capacity needed based on the current draw of your system and your desired flight time.
- ❑ 6. Determine the ESC you need based on the system current draw shown on the motor/prop chart. See the ESC section.

PROCEDURE #2: If you know the approximate weight of your airplane, including the motor and battery, and the performance you want from it, answer the questions below to determine the correct power system for your plane. You may need to make more than one calculation using different motors and battery combinations. See the battery section for some of the battery weights for the suggested batteries.

- ❑ 1. Perform the following calculation to determine the wattage required:
 - If you expect trainer-like performance then multiply **75 x Airplane Weight (lbs)**
 - If you expect aerobatic or high speed-like performance then multiply **100 x Airplane Weight (lbs)**
 - If you expect 3D or extreme performance multiply **150 x Airplane Weight (lbs)**
- ❑ 2. The number you get is the minimum wattage you will need for your plane to perform as you wish. Look at the chart and determine what combination gives you the performance you want based on wattage and maximum propeller size that will fit on the plane.
- ❑ 3. Note the gear ratio you need.
- ❑ 4. Note the recommended battery voltage.

- ❑ 5. Determine if you want to use LiPo or NiMH batteries based on the desired ready to fly airplane weight. Select the number of cells based on the recommended voltage shown in the chart.
- ❑ 6. Determine the battery capacity needed based on the current draw of your system and your desired flight time.
- ❑ 7. Determine the ESC you need based on the system current draw.

In addition to these two procedures, you can also visit the Great Planes ElectriFly web site for descriptions of the power systems recommended for our line of electric and glow airplanes as well as more detailed explanation on the subject.

UNDERSTANDING MOTORS

kV (rpm/volt): This is a number that gets thrown around quite a bit when talking electrics and it is important to know what it is. kV is the number of rpm a motor will spin per each volt applied (rpm/volt) under no load.

This means that basically a motor that has a kV of 1000 when connected to a 12V battery will try to spin at 12,000rpm (1000x12) under no load. Likewise a 3500kV motor will try to spin at 42,000rpm (3500x12) under no load.

When a propeller is attached to the motor, the motor will try to spin the prop at the rated kV. Depending on the diameter and pitch of the propeller (the larger the diameter or higher the pitch, the harder it is to spin), the motor's current draw can be increased or decreased. There are meters available from your hobby dealer that measure current and voltage.

Because every motor has a maximum current it can take based on its design and cooling ability, the maximum size of propeller that can be used with each motor can be determined. Too large of a propeller and the motor will spin at a much lower rpm than its rated kV, causing it to draw a lot of current and overheat. If the propeller/fan is too small, it will require little effort (current) to turn the prop at the rated kV.

Ideally the motor should be matched with a propeller that causes the motor to draw 80-100% of its rated maximum constant current. Once a power system is set up, it can be fine-tuned by adjusting the propeller size and measuring the amount of current the motor is drawing.

Please note that the kV of a motor does not change with voltage, but if a higher voltage is applied to the motor, it will try to spin the same propeller at a higher rpm. This will cause the motor to draw more current and possibly exceed the maximum rated current of the motor. So, if a battery with lower voltage is replaced with one with a higher voltage, it is

recommended that a smaller propeller be used to keep the current in check. If a higher voltage battery is replaced by a lower voltage battery, the size of the propeller can be increased to keep the motor at its rated current.

Another possibility to fine tune the power system's performance is to use another motor with higher kV to increase the current or a lower kV to lower the current.

ASSEMBLE YOUR POWER SYSTEM

INSTALL THE PINION GEAR

Once you have determined the gear ratio you need, the pinion gear will need to be installed on the motor shaft. The pinion gear is a press fit on the motor shaft and it will need to be heated and pressed on. Never force the pinion gear on the shaft without supporting the other end of the motor shaft. A small wheel collar works well for supporting the motor shaft. If you have a drill press, the motor can be placed in a vise with the motor shaft supported on a small wheel collar. Use a small micro torch to heat the pinion gear and use the drill chuck of the drill press to press the pinion onto the shaft. **Note:** The pinion gear uses a small set screw to secure the pinion gear to the motor shaft. When installing the pinion gear make sure that the flat on the motor shaft is aligned with the set screw.



If you do not have a drill press a small vise can also be used. Place the motor between the jaws of the vise with the end of the motor shaft supported and the pinion gear centered on the motor shaft. Heat the pinion gear and slowly close the jaws of the vise. You may need to use a second wheel collar so that the pinion gear can be pressed on past the end of the motor shaft.

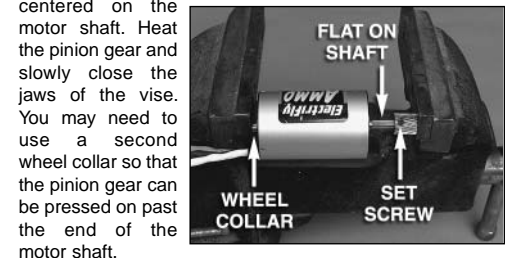

Once the pinion gear is in position on the motor shaft, apply a drop of Great Planes **Threadlocker (GPMR6060)** to the threads of the set screw and tighten it down on the flat of the motor shaft.

REMOVAL OF THE PINION GEAR

The best method of removing the pinion gear is by heating it with a micro torch and using a pinion puller to carefully pull the gear off.

REPLACING THE SPUR GEAR



REMOVE 2.5x17mm
F/H SCREWS



To remove the spur gear, loosen and remove the two 2.5x17mm flat head machine screws and 5.5mm aluminum spacers. Remove the backplate, being careful to not lose the 6mm bearing spacer.

Press the output shaft out of the spur gear and remove the spur gear pin. The spur gear can now be replaced. Reverse the order to reassemble the gear drive. Be sure to use a drop of threadlocker on the two 2.5x17mm flat head machine screws to prevent them from loosening during operation.



SPUR GEAR PIN

70/14 = 5:1

70/20 = 3.5:1

90/14 = 6.42:1

90/20 = 4.5:1

MOUNT THE MOTOR TO THE GEAR DRIVE



Loosely mount the motor to the back of the back plate with two 3x23mm SHC screws and two 3mm flat washers. Place a piece of notebook paper between the pinion gear and the spur gear. Squeeze the two gears together while tightening the two 3x23mm SHC screws. Remove the piece of paper and the gear mesh should be set. Rotate the gears to make sure they rotate smoothly. If they do not, slightly loosen the SHC screws and adjust the gear mesh until the gears do rotate smoothly.

MOUNT THE BRUSHLESS LARGE MOTOR MOUNT

In the center of the header card you will find the mounting hole pattern template for the Brushless Large Motor Mount. The Motor Mount has the same bolt mounting pattern as the Great Planes .40-.70 and .60-1.20 Nylon Engine Mounts. If you are replacing a glow engine with an electric motor system, remove the nylon engine mount and replace it with the Large Motor Mount using the same bolts to attach it to the firewall. If the firewall has not been drilled for an engine mount and blind nuts, use the mounting template on the header card to locate the mounting holes.

Attach the Backplate to the firewall using four 6-32 machine screws and four #6 flat washers when replacing the .40-.70 nylon mount; or four 8-32 machine screws and four #8 flat washers when replacing the .60-1.20 nylon mount. Note that if you are using a gear drive you may have to cut a hole in the firewall for the motor. The motor and gear drive can be mounted to the Front Plate using the 3x8mm machine screws. If you are using a gear

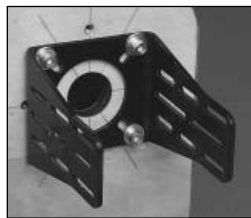

drive other than the Great Planes gear drive, the hole locations may need to be modified. Also, if you are mounting the motor to a firewall, longer screws may be required.

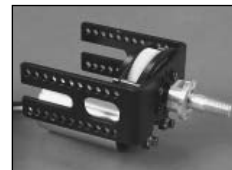

In-runner motors that will be run direct drive or gear drive and are mounted inside the front plate.

Install the prop adapter on the motor shaft or gear drive output shaft. The Brushless 36mm Gear Drive uses a 6mm prop adapter (**GPMQ4968 Collet Type or GPMQ4942 Set Screw Type**). The Ammo 36mm motors direct drive uses the 5mm prop adapter (**GPMQ4966 Collet Type or GPMQ4939 Set Screw Type**).

COLLET TYPE PROP ADAPTER INSTALLATION

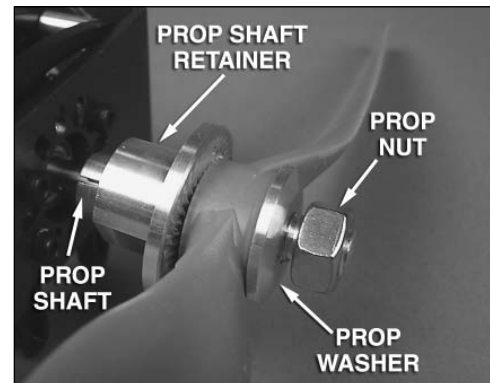

Slide the prop shaft over the output shaft of the gear drive or motor. Next slide the prop shaft retainer over the prop shaft. Note that the hole through the retainer is tapered. Make sure that the side with the larger diameter hole is installed first. Install the spinner backplate (if used, **not included**), the prop, prop washer and then the prop nut. Tighten the prop nut against the prop. This will cause the tapered hole in the prop shaft retainer to squeeze the prop shaft around the output shaft. Carefully pull on the prop to make sure it is securely attached to the output shaft of the gear drive.

SET SCREW TYPE PROP ADAPTER INSTALLATION

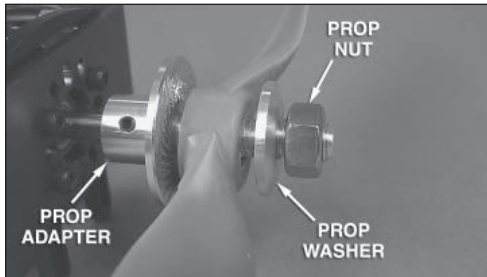

Slide the prop adapter over the output shaft of the gear drive or motor. Align one of the set screws with the flat on the output shaft of the gear drive. Apply a drop of threadlocker to the set screw and install it in the prop adapter, tightening it against the flat of the gear drive output shaft. Remove the second set screw that does not tighten onto the flat. When installing the prop adapter onto a shaft that does not have a flat spot, tighten both of the set screws against the shaft. Install the spinner backplate (if used, **not included**), the prop, prop washer and then the prop nut. Tighten the prop nut against the prop. Carefully pull on the prop to make sure it is securely attached to the output shaft of the gear drive.



Determine the distance the prop adapter needs to be from the firewall by using the recommended distance in the airplane instructions or by installing the cowl and measuring the distance from the firewall to the front of the cowl. Add approximately 3/32" to 1/8" to the distance. Attach the Front Plate of the motor mount to the Back Plate using the eight 6-32x1/2" SHC screws, eight #6 flat washers and four aluminum screw plates, spaced out as far as possible. A drop of Threadlocker on the threads of the screws will prevent the screws from coming loose.

MOTOR BRACKET INSTALLATION (OPTIONAL)

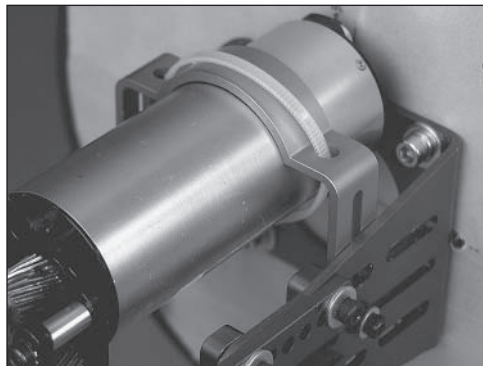

The Large Motor Mount comes with an optional Motor Bracket. If you have installed a 40mm or longer motor in the Motor Mount; we recommend installing the optional Motor Bracket. Attach the Motor Bracket to the sides of the Motor Mount using two 4-40x1/2" SHC screws, #4 flat washers and 4-40 lock nuts. Position the Motor bracket as far back on the motor as possible. Once the Motor Bracket is installed, secure the motor to the Motor Bracket using the nylon strap.

INSTALL THE BRUSHLESS ESC

Because most of the power systems using the 36mm Ammo motor are drawing more than 35 amps continuous, the ElectriFly **SS-45 Brushless ESC (GPMM1840)**, for power systems drawing less than 45 amps, works well. If you will be using an Ammo motor and prop combination that draws more than 45 amps continuous, use the **SS-60, SS-80 or SS-100 Brushless ESC**. Always make sure that the ESC is positioned so that it gets some cooling air flowing over it.

Use the instructions included with the brushless ESC to correctly connect the ESC.

AMMO MOTOR MAINTENANCE

Ammo brushless motors require virtually no maintenance. There are no brushes to wear out and replace. The precision bearings have a very long service life and should last a very long time. The internal parts of the motor should not require any cleaning.

IMPORTANT PRECAUTIONS

- Once the battery is connected to the ESC, stay clear of the motor and prop.
- DO NOT apply an input voltage that exceeds the maximum specification of each motor.
- DO NOT apply currents to the motor that exceed the maximum specifications of each motor.
- DO NOT allow the input connectors to accidentally touch each other while power is applied to the motor. Make sure all input connections are insulated electrically.
- DO NOT allow water or moisture to enter the motor, as it can cause permanent damage to the motor and possibly short out the attached ESC.
- DO NOT cut the coated wires from the motor. If you must remove the bullet connectors, unsolder them.
- Allow the motor to cool after each flight.
- The motor shaft of the motor will rotate at very high rpm. DO NOT attempt to touch the shaft while it is rotating. If setting up the motor/ESC on the workbench, make sure the motor is securely attached and that nothing is attached to the motor shaft BEFORE applying power.
- Never attempt to use a damaged motor (having mechanical or electrical defects).
- Great Planes carries a complete line of Ammo (in-runner style) and RimFire (out-runner style) brushless motors, gear drives, motor mounts, prop adapters and speed controls. For a complete list of these products, check out our web site at:

www.greatplanes.com
www.electrifly.com

or visit your nearest hobby shop that carries the full line of Great Planes and Electrifly products.