

RIMFIRE™

150 POWER SYSTEM



ElectriFly
by Great Planes

Thank you for purchasing the RimFire 150 brushless outrunner motor! You'll be pleased with the performance of this micro motor. We've carefully designed this motor to give you the best performance while using the most popular propellers and batteries. To get the most out of your RimFire 150, please use only a 7.4V (2S) LiPo battery. The following instructions will help you mount your motor and select the right components to complete your power system.

1 MOTOR SPECIFICATION

Model	Stock #
RimFire 150 (14-17-3000)	GPMG4453

The RimFire motors are labeled to provide the most information at a glance. For example: the RimFire 150 (14-17-3000) is 14mm in diameter, 17mm long, and has a kV (rpm-per-1volt) of 3000 rpm.

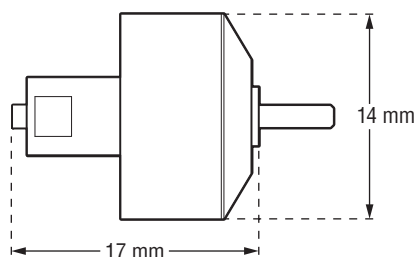

Motor Diameter 0.55 in (14 mm)	Connectors 3-pin micro
Overall Length 0.63 in (15.9 mm)	Max. Constant Current 2.8 A
Shaft Diameter 0.059 in (1.5 mm)	Max. Surge Current 3.2 A
Shaft Length 0.20 in (5 mm)	Max. Constant Watts 21 W
Lead Length 0.87 in (22 mm)	Burst Watts 24 watts
	No Load Current 0.17 A
	Input Voltage 7.4V (2S LiPo)
	Weight
	0.20 oz (5.6 g) motor only
	0.25 oz (7.1 g) motor, mount, & prop adapter

2 ELECTRONIC SPEED CONTROL (ESC)

An ESC is basically the device that controls your motor through your radio system. Never run any RimFire motors with a brushed ESC. It will not work and you may damage both the motor and the ESC. Always use a brushless ESC. When choosing an ESC, choose one that is rated to handle at least the maximum current your power system will draw during full-throttle operation. ElectriFly offers Brushless ESCs that will work with the RimFire 150 motor.

For the RimFire 150 we recommend this high quality, lightweight ESC:



FlightPower®
6A Brushless ESC w/BEC (FPWM0206)
Weight = 0.20oz [5.7g]

3 BATTERIES

Cells can be connected in series or in parallel. Usually batteries are labeled by their number of cells, such as a 2-cell LiPo. This means the cells are connected in SERIES (S). Arranging batteries in series gives you more power (higher voltage).

- Each LiPo battery has 3.7V, so a 2-cell LiPo battery has $3.7 \times 2 = 7.4V$

When selecting batteries, please consider weight. Because of this, we recommend the following batteries:



Great Planes® ElectriFly
200mAh 7.4V 2S 15C LiPo (GPMP0694)
Weight = 0.48oz [13.5g]



Great Planes ElectriFly
300mAh 7.4V 2S 20C LiPo (GPMP0700)
Weight = 0.7oz [19.6g]

Due to the constantly changing battery technology, check out the ElectriFly web site at www.electrifly.com for the most up-to-date listing of the ElectriFly battery line.

4 PROPELLER

For any given voltage, an electric motor's load is determined by the propeller chosen. A propeller that is too small will not take advantage of the power that the motor can produce. A propeller that is too large will cause current draw to exceed the maximum allowed continuous current. This can catastrophically damage the motor and/or ESC.

The first number in a propeller designation is the diameter in inches. The second number refers to the theoretic pitch in inches traveled for one complete rotation of the prop. So, a 6x3 propeller measures 6" [152mm] in diameter and travels 3" [76mm] forward for one complete revolution (360°). Generally, when sizing up a prop going up in diameter gains more thrust (immediate punch-out power). Going up in pitch results in a higher top speed.

For the RimFire 150 we recommend the following propellers.

Best all-around performance

GWS 5 x 4.3 Propeller (GWSQ5043), 2.8A @ 7.4V, 8490rpm

Sport performance

GWS 4.5 x 4 Propeller (GWSQ2034), 2.5A @ 7.4V, 9810rpm

3D burst performance

GWS 6x3 Propeller (GWSQ2007), 3.0A @ 7.4V, 8130rpm

Note: Do not fly this set up at full throttle for more than a few seconds at a time.

5 DETERMINE WHAT YOU NEED TO BUILD YOUR POWER SYSTEM

Now that you have one component for your power system, there are several different ways to select the rest. In time, experience will help you to determine what works best for you, but an easy way to determine what you need now is the following.

Procedure #1: If you know the size of the propeller you want to turn and the rpm, then:

1. Find the combination that delivers the closest performance to what you want (refer to the ElectriFly web site for typical combinations), or refer to the airplane manufacturer's recommendations.
2. Note the recommended battery voltage.
3. Determine the battery capacity needed based on the current draw of your system and your desired flight time.

4. Determine the ESC you need based on the system current draw. See the ESC section.

Procedure #2: If you know the approximate weight of your airplane, including the motor and battery, and the performance you want from it, answer the questions below to determine the correct power system for your plane. You may need to make more than one calculation using different motors and battery combinations. See the battery section for some of the battery weights for the suggested batteries.

1. Perform the following calculation to determine the wattage required:
 - If you expect trainer-like performance, then multiply $75 \times \text{Airplane Weight (lbs)}$.
 - If you expect aerobatic or high speed-like performance, then multiply $100 \times \text{Airplane Weight (lbs)}$.
 - If you expect 3D or extreme performance, multiply $150 \times \text{Airplane Weight (lbs)}$.

Note: To convert grams to lbs, divide by 454. To convert ounces to lbs, divide by 28.

2. The number you get is the minimum wattage you will need for your plane to perform as you wish. $\text{Watts} = \text{current (A)} \times \text{voltage (V)}$. Using suggested power system combinations for reference, determine what combination gives you the performance you want based on wattage and maximum propeller size that will fit on the plane.

3. Note the recommended battery voltage.

4. Determine the battery capacity needed based on the current draw of your system and your desired flight time.

5. Determine the ESC you need based on the system current draw. In addition to these two procedures, you can also visit the Great Planes ElectriFly web site for descriptions of the power systems recommended for our line of electric airplanes as well as more detailed explanation on the subject.

Essentially, the maximum weight of your model (fully equipped w/ battery, radio, etc.) should be as follows when using this model.

Trainer	4.4oz [125g]
Sport	3.3oz [94g]
3D	2.2oz [63g]

To help you plan your power system requirements for your project, use the following table to come up with a total weight. Keep in mind that weight is critical in this size range.

WEIGHT TABLE	RimFire 150	7.1 grams
	Prop	
	Battery	
	Servos	
	Receiver	
	ESC	
	Airframe	
Total Weight		

6 MOTOR INSTALLATION

1. Cut out the mounting template at the end of this manual. Line up the crosshair alignment marks on the template with the marks on the firewall of your model. Stick the template in place. Select the inner "X" mounting holes or the outer "+" mounting holes. Drill two mounting screw holes in the firewall using a 1/16" [1.6mm] drill.

2. Install the mount onto the firewall using two #2 x 3/16" [4.8mm] sheetmetal screws (not included). Remove the screws and harden the screw hole with thin foam-safe CA. Reinstall the mount.



3. Fit the motor to the mount. Rotate the motor so that the motor wires can be routed in the desired direction. Install the two set screws using thread locking compound on the screw threads. With the motor in position, tighten the set screws securely.



4. The prop adapter is stepped to fit 3mm and 4mm prop hubs. We have also included a 5mm and a 6mm bushing.



5. You have two options when installing the propeller. To install the propeller using the standard method, install the two set screws in the prop adapter hub. Fit the prop and bushing (if needed) and install the prop washer and screw. Use thread locking compound on all screw threads.



6. If you choose to use the "prop saver" attachment method, install the two M2 x 6mm countersunk machine screws in the prop adapter hub. Fit the prop and bushing (if needed) and fit the prop. Hook the rubber O-ring to one of the countersunk screws. Stretch it across the hub of the prop and hook it onto the other countersunk screw to retain the propeller. Use thread locking compound on all screw threads.



If mounting space is a concern, you can flip the motor mount around and decrease the amount of space you need to mount the motor. If you want to do this, use the template in this manual to help you grind away a hole to allow the motor mount to drop in.

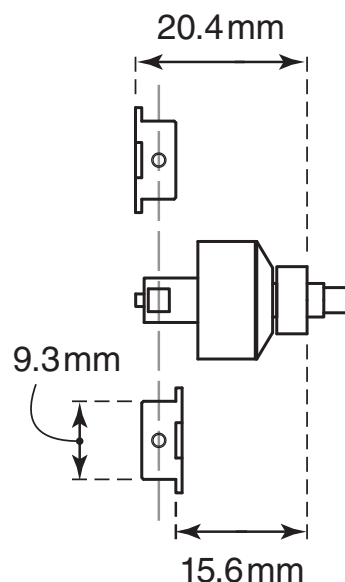

7 ESC INSTALLATION

We recommend that you use a variable temperature soldering iron with a very fine tip. We suggest using the Team Checkpoint® TC-950 Soldering Station (TCPR0950) with the 1mm pencil tip. A set of "helping hands" is also useful for soldering (XACR4214).

1. Strip off about 1/8" [3.2mm] of insulation from the end of each motor wire on the ESC. Apply some soldering flux to the bare wires and twist the end of each wire to neatly tighten the strands. Do this for each individual wire. Tin the tips of each wire using electrical solder.

2. Cut three pieces of heat shrink tubing to a length that completely covers each bare wire. Generally, you'll need about 5/16" [7.9mm] of heat shrink to cover each wire, but enough material is provided for you if you need more. Apply flux and tin each pin of the female connector as well.

3. Fit the heat shrink tubing to each wire and slide it as far away from the tip of the wire as you can. Solder each ESC lead to each pin of the included female 3-pole micro connector. Slide the pieces of heat shrink tubing into position and use heat to shrink the tubing. Note: Any wire can be connected to any pin.

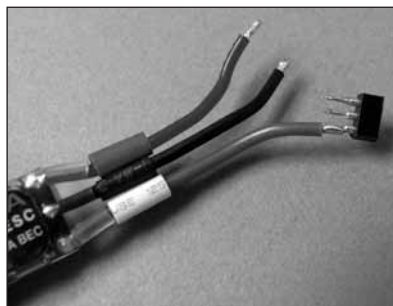

4. Mount the ESC to your model using double-sided tape or hook and loop material. Make sure that you choose a place that will allow all of the wires to reach. Plug the ESC signal lead into your receiver.

5. Connect the male motor connector to the female ESC connector. Energize your radio system. Connect a 2-cell LiPo battery to the ESC. Using the throttle, test the direction of motor rotation. The motor should rotate counter-clockwise as viewed from the front of the

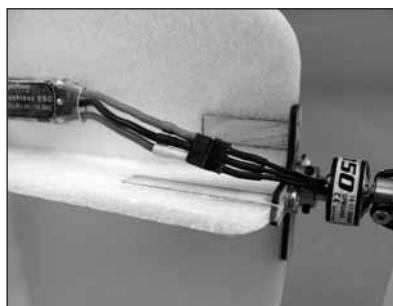

motor. If it does not rotate correctly, unplug the micro 3-pole connector and rotate it 180°. This will reverse the motor rotation. **Note:** Do not install the prop for this step.

8 RIMFIRE MOTOR MAINTENANCE

RimFire brushless motors require virtually no maintenance. There are no brushes to wear out and replace. The precision bearings have a very long service life and should last a very long time. The internal parts of the motor should not require any cleaning. The only thing that needs to be checked is to make sure all the screws and set screws remain tight.

9 IMPORTANT PRECAUTIONS

Once the battery is connected to the ESC, stay clear of the motor and prop.

- **DO NOT** apply an input voltage that exceeds the maximum specification of each motor.
- **DO NOT** apply currents to the motor that exceed the maximum specifications of each motor.
- **DO NOT** allow the input connectors to accidentally touch each other while power is applied to the motor. Make sure all input connections are insulated electrically.
- **DO NOT** allow water or moisture to enter the motor, as it can cause permanent damage to the motor and possibly short out the attached ESC.
- **DO NOT** cut the coated wires from the motor. If you must remove the connector, please unsolder it.
- Allow the motor to cool after each flight.
- The shaft of the motor will rotate at very high rpm. **DO NOT** attempt to touch the shaft while it is rotating. If setting up the motor/ESC on the workbench, make sure the motor is securely attached and that nothing is attached to the motor shaft BEFORE applying power.
- **NEVER** attempt to use a damaged motor (having mechanical or electrical defects).
- ElectriFly carries a complete line of Ammo™ (in-runner style) and RimFire (out-runner style) brushless motors, gear drives, motor mounts, prop adapters and speed controls. For a complete list of these products, check out our web site at: www.greatplanes.com www.electrifly.com or visit your nearest hobby shop that carries the full line of Great Planes and ElectriFly products.

If you need to reduce the mounting space, flip over the motor mount and cut out this hole.

