

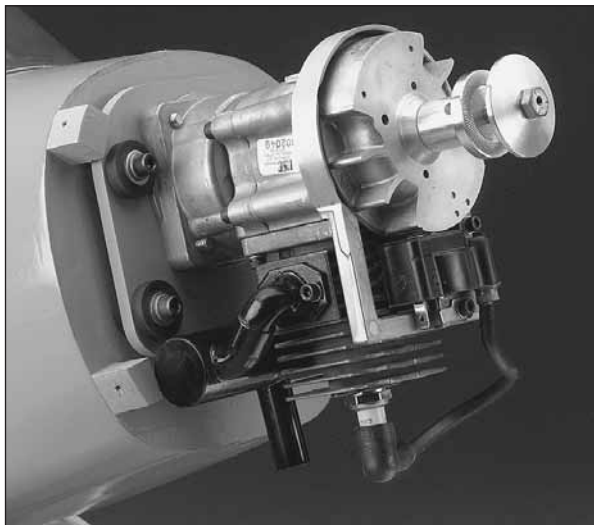

LARGE ENGINE ISOLATION MOUNT

Assembly Instructions



The **Large Engine Isolation Mount™** provides a simple but effective way to mount your large gas or glow engine. It is effective at dampening normal engine vibration, which in turn will extend the life of both your airplane and your radio system. It will also effectively reduce noise due to vibration.

CAUTION: Proper balancing of your propeller is essential. This engine mount system WILL NOT compensate for an out of balance propeller. The rubber grommets are designed to work under normal engine vibration and will be quickly damaged under heavier than normal vibration.

Great Planes Model Manufacturing

3002 N Apollo Drive, Suite 1 Ph: (217) 398-8970, ext. 5
Champaign, IL 61822 Fax: (217) 398-7721

E-mail: airsupport@greatplanes.com

Web page: greatplanes.com

NOTE: The rubber grommets are designed to absorb the vibration energy from your engine. It is normal for them to wear during usage. You should inspect the grommets for excessive wear after the first five hours of operation and every ten hours thereafter (more often if excessive wear is noted). Replacement grommets are available at minimal cost. You should replace the grommets when wear becomes noticeable.

PREPARE THE ENGINE MOUNT:

❑ 1. The 1/4" Birch Ply Mount has been designed for use with a variety of models & engines. It may be necessary to modify it for your particular application. For example, the dashed lines on the upper corners of the enclosed template, show where to cut off material to fit the Dynaflyte™ Super Cub or Dynaflyte Fly Baby.

❑ 2. Compare the Ply Mount with the side and top views of the fuselage plan to determine if you will need to trim the height or width of the mount, **BUT DO NOT CUT IT YET.**

❑ 3. Using the **SIDE VIEW** of the fuselage, place your engine at the proper location and orientation. Be sure to align the center of the crankshaft with the thrust line shown on the plans. Place the Ply Mount against the back of the engine. Move the Ply Mount up or down to obtain the best location for mounting it to the fuselage. Mark the Ply Mount for the vertical height of the engine mounting bolts. Also, mark the location of the Ply Mount on the firewall.

❑ 4. Use the **TOP VIEW** of the fuselage to place your engine at the proper location and orientation. Be sure to align the center of the crankshaft with the thrust line shown on the plans, noting any thrust angle. Place the Ply Mount against the back of the engine. Move the Ply Mount left or right to obtain the best location for mounting it to the fuselage. Mark the Ply Mount for the horizontal location of the engine mounting bolts. Also, mark the location of the Ply Mount on the firewall.

❑ 5. Mark the center line locations of the holes to be drilled for the engine mount bolts, **BUT DO NOT DRILL THEM YET.**

❑ 6. Determine how you will mount the Ply Mount to the aircraft firewall, keeping in mind that the grommets will cause the Ply Mount to be spaced 1/4" from the firewall. On Many airplanes it will simply be a matter of bolting it directly to the firewall with the supplied bolts. On others you may need to build spacers onto the firewall. If you have not yet mounted the firewall in the aircraft, you may be able to adjust it to better fit the Ply Mount.

MOUNT THE ENGINE TO THE PLY MOUNT:

You are now ready to drill the engine mounting holes in the Ply Mount. Remember the old carpenters saying: "Measure twice, cut once".

❑ 1. Drill 1/4" holes at the locations you marked for the engine bolts.

❑ 2. Mount the engine to the Ply Mount using 1/4-20 x 1" bolts and 1/4" flat washers (not supplied).

MOUNT THE ENGINE AND PLY MOUNT TO THE FIREWALL:

You must now determine where to drill the holes for the mounting bolts. When doing so, keep in mind the clearances needed for the rubber grommets. If your mount comes with pre-drilled holes, skip to Step 4.

❑ 1. Place the Engine/Ply Mount on the firewall using the reference marks you made earlier. The Ply Mount will not fit directly against the firewall as the engine mounting bolts are on the rear of the Ply Mount.

❑ 2. Referring to the plans, double check the location again. Determine the best location for the mounting bolts, then mark the Ply Mount for the mounting bolts. Remember that the rubber grommets will be mounted to the front and rear of the Ply Mount and could conflict with parts of the engine. Also keep in mind any parts of the airplane structure that could conflict with the mounting bolts or blind nuts.

❑ 3. Drill 1/2" holes in the Ply Mount at the locations you marked.

❑ 4. Install the eight rubber grommets in the Ply Mount. Place the Engine/Ply Mount back on the firewall and mark the location of the holes to be drilled in the firewall.

❑ 5. Drill 5/16" holes in the firewall at the locations you marked. Install the 1/4-20 blind nuts in these holes.

NOTE: The engine bolt heads on the rear of the Ply Mount will touch the firewall. Mark the firewall where the bolt heads touch.

❑ 6. You will need to cut or drill clearance holes where the engine bolts touched the firewall. Either partially drill into the firewall with a 1/2" drill or use a Dremel® MultiPro™ tool to hollow out a clearance area.

❑ 7. Bolt the Engine/Ply Mount to the firewall using the 1/4-20 x 1-1/4" bolts and 1/4" flat washers. If you had to install spacers on the firewall, you may need to obtain longer bolts.

ENGINE SIDE VIEW:

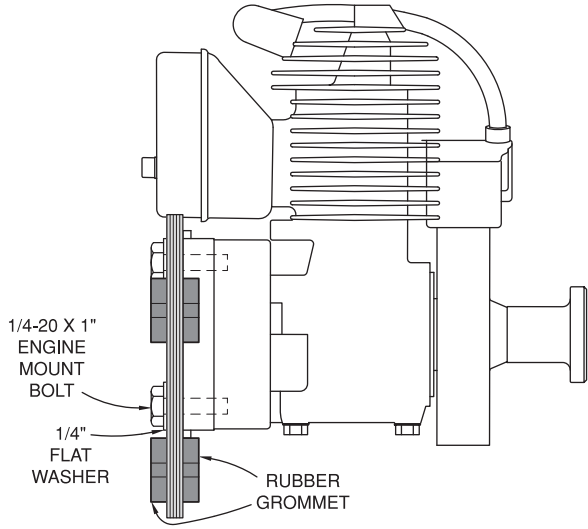

ENGINE MOUNT TEMPLATE
US ENGINES GASOLINE ENGINE
(WILL FIT DIRECTLY THE DYNAFLITE
SUPER CUB OR FLY BABY)

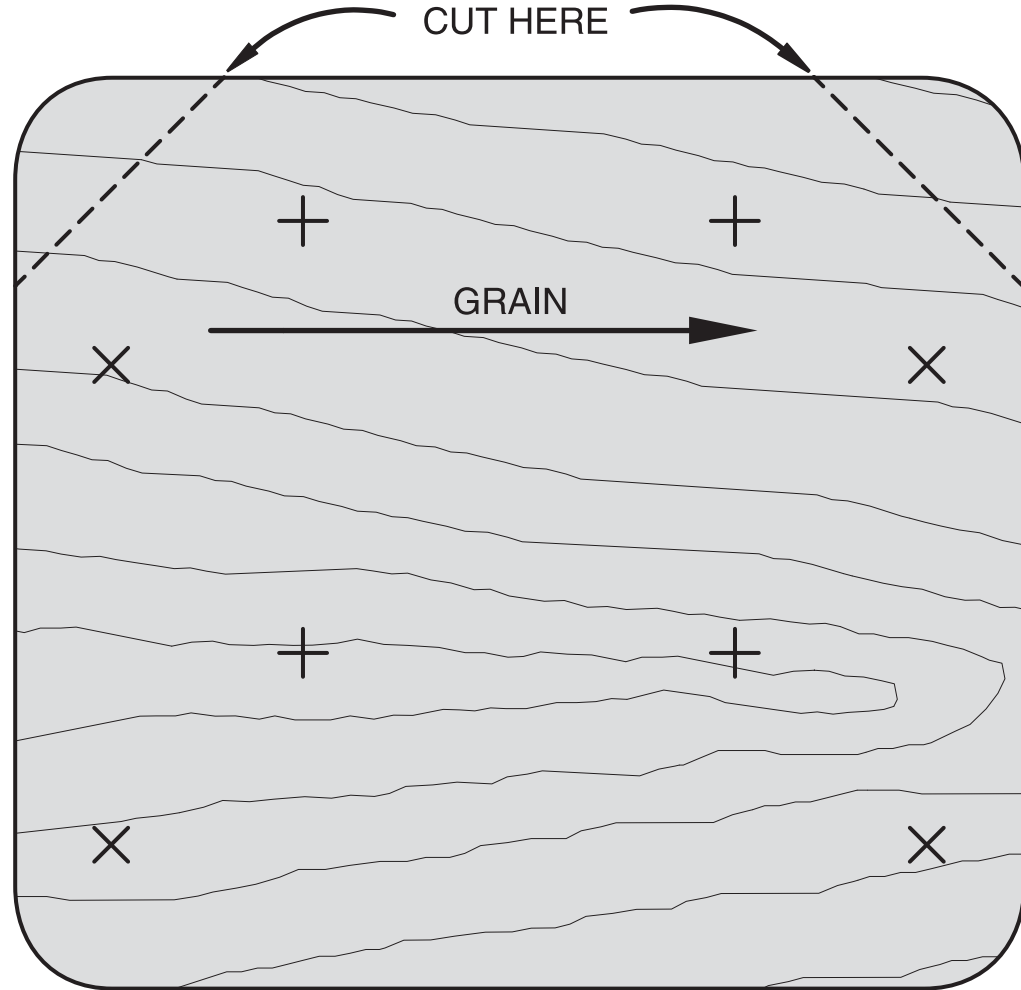

PARTS LIST:

Part#	Qty.	Description
PLYS018.....	(1)	1/4" Birch Ply Mount
SUB2000.....	(1)	Hardware Subpack

Hardware Subpack (includes the items listed below):
 SCRW114.....(4)..... 1/4-20 x 1-1/4" Bolt
 WASHER03.....(4)..... 1/4" Flat Washer
 NUTS020.....(4)..... 1/4"-20 Blind Nut
 RBUSH01.....(8)..... Rubber Bushing

+ CENTER OF 1/4" HOLE FOR
 1/4-20 ENGINE MOUNT BOLTS

X CENTER OF 1/2" HOLE FOR
 RUBBER VIBRATION GROMMETS