

ELECTROSTIK™ RXR

INSTRUCTION MANUAL

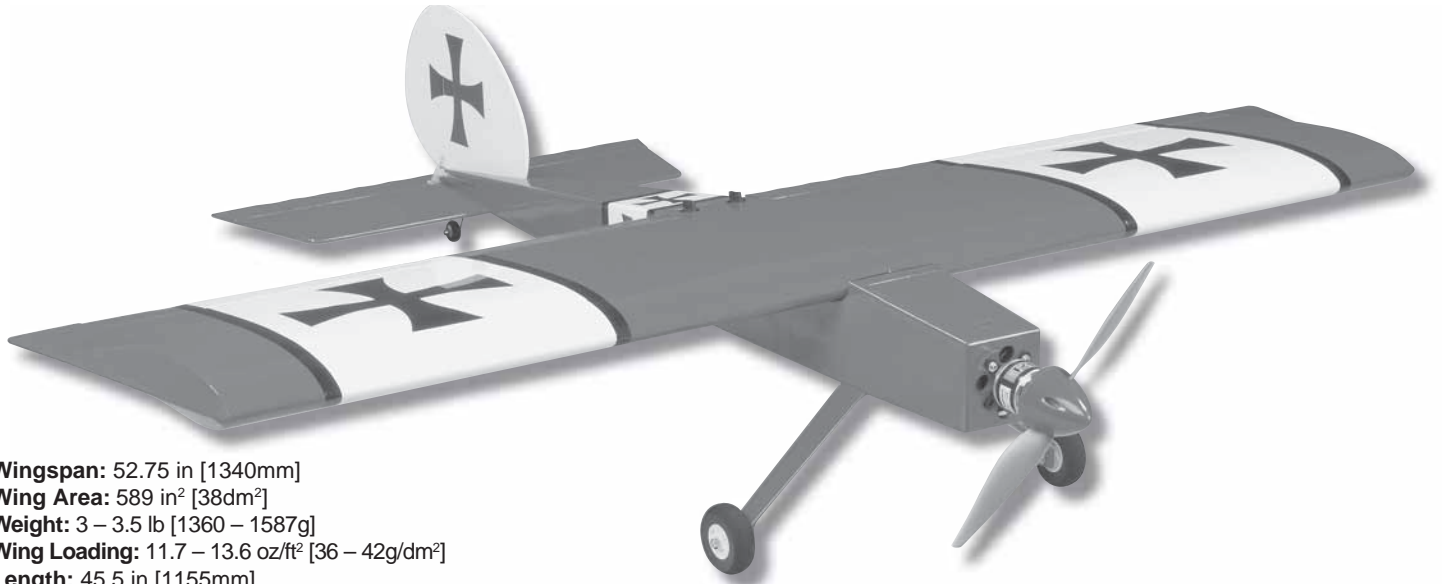

Wingspan: 52.75 in [1340mm]
Wing Area: 589 in² [38dm²]
Weight: 3 – 3.5 lb [1360 – 1587g]
Wing Loading: 11.7 – 13.6 oz/ft² [36 – 42g/dm²]
Length: 45.5 in [1155mm]
Radio: 4-channel radio system
Motor: RimFire 42-40-1000

WARRANTY

Great Planes® Model Manufacturing Co. guarantees this kit to be free from defects in both material and workmanship at the date of purchase. This warranty does not cover any component parts damaged by use or modification. **In no case shall Great Planes' liability exceed the original cost of the purchased kit.** Further, Great Planes reserves the right to change or modify this warranty without notice.

In that Great Planes has no control over the final assembly or material used for final assembly, no liability shall be assumed nor accepted for any damage resulting from the use by the user of the final user-assembled product. By the act of using the user-assembled product, the user accepts all resulting liability.

If the buyer is not prepared to accept the liability associated with the use of this product, the buyer is advised to return this kit immediately in new and unused condition to the place of purchase.

To make a warranty claim send the defective part or item to Hobby Services at the address below:

Hobby Services
3002 N. Apollo Dr., Suite 1
Champaign, IL 61822 USA

Include a letter stating your name, return shipping address, as much contact information as possible (daytime telephone number, fax number, e-mail address), a detailed description of the problem and a photocopy of the purchase receipt. Upon receipt of the package the problem will be evaluated as quickly as possible.

READ THROUGH THIS MANUAL BEFORE STARTING CONSTRUCTION. IT CONTAINS IMPORTANT INSTRUCTIONS AND WARNINGS CONCERNING THE ASSEMBLY AND USE OF THIS MODEL.



Champaign, Illinois
(217) 398-8970, Ext 5
airsupport@greatplanes.com

TABLE OF CONTENTS

INTRODUCTION	2
AMA	2
SAFETY PRECAUTIONS	2
DECISIONS YOU MUST MAKE	3
Radio Equipment	3
Battery & Charger Options	3
POWER SYSTEM	3
ADDITIONAL ITEMS REQUIRED	3
Accessories & Building Supplies	3
Optional Supplies & Tools	4
IMPORTANT BUILDING NOTES	4
ORDERING REPLACEMENT PARTS	4
COMMON ABBREVIATIONS	5
METRIC CONVERSIONS	5
KIT INSPECTION	6
KIT CONTENTS	6
METRIC/INCH RULER	6
PREPARATIONS	7
ASSEMBLY	7
Assemble the Wing	7
Optional - Dual Aileron Servos	7
Assemble the Fuselage	8
Battery & Radio Installation	10
Install the Propeller	11
GET THE MODEL READY TO FLY	11
Install & Connect the Motor Battery	11
Check the Control Directions	11
Set the Control Throws	12
Balance the Model (C.G.)	12
Balance the Model Laterally	12
PREFLIGHT	13
Identify Your Model	13
Charge the Batteries	13
Balance Propellers	13
Ground Check & Range Check	13
MOTOR & BATTERY PRECAUTIONS	13
LITHIUM BATTERY HANDLING & USAGE	14
PROPER CARE OF YOUR MOTOR	14
AMA SAFETY CODE (excerpts)	14
CHECK LIST	15
FLYING	15
Takeoff	15
Flight	Back Cover Page
Landing	Back Cover Page

INTRODUCTION

Thank you for purchasing the Great Planes ElectroStik EP RXR. The "Stick" (or "Stik") model is a popular and proven design that has been around for many years with very little change. Now we've brought this model into the 21st century as an electric powered RXR that can be assembled in minutes and flight ready in less than a day!

For the latest technical updates or manual corrections to the Great Planes ElectroStik EP RXR visit the Great Planes web site at www.greatplanes.com. Open the "Airplanes" link and then select the ElectroStik EP RXR. If there is new technical information or changes to this model a "tech notice" box will appear in the upper left corner of the page.

AMA

If you are not already a member of the AMA, please join! The AMA is the governing body of model aviation and membership provides liability insurance coverage, protects modelers' rights and interests and is required to fly at most R/C sites.



Academy of Model Aeronautics
5151 East Memorial Drive
Muncie, IN 47302-9252
Tele. (800) 435-9262
Fax (765) 741-0057
Or via the Internet at:
<http://www.modelaircraft.org>

IMPORTANT!!! Two of the most important things you can do to preserve the radio controlled aircraft hobby are to avoid flying near full-scale aircraft and avoid flying near or over groups of people.

PROTECT YOUR MODEL, YOURSELF & OTHERS...FOLLOW THESE IMPORTANT SAFETY PRECAUTIONS

1. Your ElectroStik EP RXR should not be considered a toy, but rather a sophisticated, working model that functions very much like a full-size airplane. Because of its performance capabilities, the ElectroStik EP RXR, if not assembled and operated correctly, could possibly cause injury to yourself or spectators and damage to property.

2. You must assemble the model **according to the instructions**. Do not alter or modify the model, as doing so may result in an unsafe or unflyable model. In a few cases the instructions may differ slightly from the photos. In those instances the written instructions should be considered as correct.

3. You must take time to **build straight, true and strong**.

4. You must use an R/C radio system that is in good condition, a correctly sized motor, and other components as specified in this instruction manual. All components must be correctly installed so that the model operates correctly on the ground and in the air. You must check the operation of the model and all components before **every** flight.

5. If you are not an experienced pilot or have not flown this type of model before, we recommend that you get the assistance of an experienced pilot in your R/C club for your first flights. If you're not a member of a club, your local hobby shop has information about clubs in your area whose membership includes experienced pilots.

We, as the kit manufacturer, provide you with a top quality, thoroughly tested kit and instructions, but ultimately the quality and flyability of your finished model depends on how you build it. Therefore, we cannot in any way guarantee the performance of your completed model, and no representations are expressed or implied as to the performance or safety of your completed model.

Remember: Take your time and follow the instructions to end up with a well-built model that is straight and true.

DECISIONS YOU MUST MAKE

This is a partial list of items required to finish the ElectroStik EP RXR that may require planning or decision making before starting to build. Order numbers are provided in parentheses.

Radio Equipment

The ElectroStik EP RXR requires a minimum 4-channel radio system.

- 6" [152.4mm] servo extension for the aileron servo

Battery & Charger Options

The Great Planes ElectroStik EP RXR is designed for use with LiPo (Lithium-Polymer) batteries only. All LiPo batteries require a charger specifically designed for charging LiPo batteries. The use of a charger not designed for charging LiPo batteries will result in damage to the batteries and possibly a fire. We recommend the use of the Great Planes Triton™2 DC Peak Charger (GPMM3153) or for charging more than one battery at a time, the ElectriFly™ PolyCharge4™ (GPMM3015). The Great Planes Triton2 charger will only charge one pack at a time, but is capable of charging NiCd, NiMH, LiPo, and lead acid batteries. Order numbers for the battery packs are provided below:

- Great Planes LiPo 3200mAh 11.1V 20C Discharge w/Balance (GPMP0623)

Note: A cell balancer is required for the LiPo battery pack listed above.

- Great Planes ElectriFly Equinox™ LiPo 1 to 5 Cell Balancer (GPMM3160)

POWER SYSTEM

The ElectroStik EP RXR is powered by a RimFire™ C42-40-1000kV with a Great Planes 11" x 8.5 propeller designed specifically for electric flight. The provided Electronic Speed Control unit is a Great Planes SS-45 brushless ESC.

The ElectriFly SS-45 brushless ESC features a brake function that is useful for some aircraft, but is unnecessary for this model. The factory default setting is "BRAKE OFF" but if you notice that the motor stops abruptly when you shut down the throttle, the ESC will need to be re-programmed. This is something that you can easily do by following these simple steps:

1. With the power "OFF" to both the transmitter and airplane, move the transmitter throttle stick to full throttle position.
2. Turn the transmitter "ON," connect the motor batteries to the ESC, and turn the plane's receiver "ON."
3. After 5 seconds the motor will beep once.
4. Move the transmitter throttle stick toward you to the "throttle down" position. The motor will beep once.
5. Again, move the transmitter throttle stick to full throttle. The motor will beep once more to confirm the brake is now "OFF". Once the brake is set, it does not require resetting once the ESC has been switched "OFF."

When turning off the system, always turn the receiver "OFF" first, followed by the transmitter. Once the motor is "armed" always remain behind the arc of the propellers until the batteries are disconnected.

ADDITIONAL ITEMS REQUIRED

Accessories & Building Supplies

In addition to common household tools and hobby tools, this is the "short list" of the most important items required to build the ElectroStik EP RXR

- 1 oz. [28g] Thin Pro™ CA (GPMR6002)
- 2 oz. [57g] Spray CA activator (GPMR6035)
- CA applicator tips (HCAR3780)
- CA debonder (GPMR6039)
- Hook & Loop material (GPMQ4480)
- #1 Hobby knife (HCAR0105)
- #11 Blades (5-pack, HCAR0211)
- Pliers (HCAR0625)
- Wire cutter (HCAR0627)
- Clear tape

Optional Supplies & Tools

Here is a list of optional items mentioned in the manual that will help finish the ElectroStik EP RXR. Order numbers are provided in parentheses.

- Stick-on segmented lead weights (GPMQ4485)
- Top Flite® MonoKote® sealing iron (TOPR2100)
- Top Flite Hot Sock™ iron cover (TOPR2175)
- Top Flite MonoKote heat gun (TOPR2000)
- C.G. Machine™ (GPMR2400)
- Precision magnetic prop balancer (TOPQ5700)
- Threadlocking compound (GPMR6060)
- Drill bits: 1/16" [1.6mm], 5/64" [2mm], 1/8" [3.2mm]
- Panel line pen (TOPQ2510)
- Rotary tool such as Dremel®
- Rotary tool reinforced cut-off wheel (GPMR8020)
- AccuThrow™ deflection gauge (GPMR2405)
- Hobbico® pin vise 1/16" collet w/6 bits (HCAR0696)
- Hobbico 7-piece ball tip hex L-wrench metric (HCAR0521)
- Great Planes clevis installation tool (GPMR8030)

...And If You Really Want to Go Nuts

- Cooler filled with ice and soda
- Folding table
- Lawn chairs
- EZ-up or canopy for shelter
- First-aid kit
- Paper towels
- Spray-on glass cleaner
- Sunglasses
- Sun block

IMPORTANT BUILDING NOTES

- When you see the term **test fit** in the instructions, it means that you should first position the part on the assembly **without using any glue**, then slightly modify or *custom fit* the part as necessary for the best fit.
- Whenever the term **glue** is written you should rely upon your experience to decide what type of glue to use. When a specific type of adhesive works best for that step, the instructions will make a recommendation.
- Whenever just **epoxy** is specified you may use **either** 30-minute (or 45-minute) epoxy **or** 6-minute epoxy. When 30-minute epoxy is specified it is **highly** recommended that you use only 30-minute (or 45-minute) epoxy, because you will need the working time and/or the additional strength.
- **Photos** and **sketches** are placed **before** the step they refer to. Frequently you can study photos in following steps to get another view of the same parts.

- The ElectroStik EP RXR is factory-covered with Top Flite MonoKote film. Should repairs ever be required, MonoKote can be patched with additional MonoKote purchased separately. MonoKote is packaged in six-foot rolls, but some hobby shops also sell it by the foot. If only a small piece of MonoKote is needed for a minor patch, perhaps a fellow modeler would give you some. MonoKote is applied with a model airplane covering iron, but in an emergency a regular iron could be used. A roll of MonoKote includes full instructions for application. Following are the colors used on this model and order numbers for six foot rolls.

Missile Red – TOPQ0201

Jet White – TOPQ0204

- The stabilizer and wing incidences and engine thrust angles have been factory-built into this model. However, some technically-minded modelers may wish to check these measurements anyway. To view this information, visit the web site at **www.greatplanes.com** and click on "Technical Data." Due to manufacturing tolerances which will have little or no effect on the way your model will fly, please expect slight deviations between your model and the published values.

ORDERING REPLACEMENT PARTS

Replacement parts for the Great Planes ElectroStik EP RXR are available using the order numbers in the **Replacement Parts List** that follows. The fastest, most economical service can be provided by your hobby dealer or mail-order company.

To locate a hobby dealer, visit the Hobbico web site at **www.hobbico.com**. Choose "Where to Buy" at the bottom of the menu on the left side of the page. Follow the instructions provided on the page to locate a U.S., Canadian or International dealer.

Parts may also be ordered directly from Hobby Services by calling (217) 398-0007, or via facsimile at (217) 398-7721, but full retail prices and shipping and handling charges will apply. Illinois and Nevada residents will also be charged sales tax. If ordering via fax, include a Visa® or MasterCard® number and expiration date for payment. Mail parts orders and payments by personal check to:

Hobby Services
3002 N. Apollo Drive, Suite 1
Champaign, IL 61822

Be certain to specify the order number exactly as listed in the **Replacement Parts List**. Payment by credit card or personal check only; no C.O.D.

If additional assistance is required for any reason, contact Product Support by e-mail at **productsupport@greatplanes.com**, or by telephone at (217) 398-8970.

Replacement Parts List

Description	How to Purchase
Missing pieces	Contact Product Support
Instruction manual	Contact Product Support
Full-size plans	Not available

Contact your hobby supplier for the following parts:

GPMA3300	Wing Set
GPMA3301	Fuselage
GPMA3302	Tail Set
GPMA3303	Landing Gear
GPMA3304	Tail Wheel
GPMA3305	Carbon Fiber Wing Joiner Tube
GPMQ4273	4mm Low Profile Landing Gear Axles
GPMQ4404	10-24 Nylon EZ Bolts
GPMQ6801	PowerFlow 11" x 8.5E Electric Propeller
GPMG4675	RimFire 42-40-100 Out-runner Brushless Motor
GPMM1840	SS-45 Brushless ESC
GPMM1220	ES-80 Micro Servo

COMMON ABBREVIATIONS

Fuse = Fuselage
Stab = Horizontal Stabilizer
Fin = Vertical Fin
LE = Leading Edge
TE = Trailing Edge
LG = Landing Gear
Ply = Plywood
" = Inches
mm = Millimeters
ESC = Electronic Speed Control

METRIC CONVERSIONS

1" = 25.4mm (conversion factor)

1/64" = .4mm	3/4" = 19.0mm
1/32" = .8mm	1" = 25.4mm
1/16" = 1.6mm	2" = 50.8mm
3/32" = 2.4mm	3" = 76.2mm
1/8" = 3.2mm	6" = 152.4mm
5/32" = 4.0mm	12" = 304.8mm
3/16" = 4.8mm	18" = 457.2mm
1/4" = 6.4mm	21" = 533.4mm
3/8" = 9.5mm	24" = 609.6mm
1/2" = 12.7mm	30" = 762.0mm
5/8" = 15.9mm	36" = 914.4mm

KIT INSPECTION

Before starting to build, take an inventory of this kit to make sure it is complete and inspect the parts to make sure they are of acceptable quality. If any parts are missing or are not of acceptable quality, or if you need assistance with assembly, contact **Great Planes Product Support**. When reporting defective or missing parts, use the part names exactly as they are written in the Kit Contents list.

Great Planes Product Support:
3002 N. Apollo Drive, Suite 1
Champaign, IL 61822
Telephone: (217) 398-8970, ext. 5
Fax: (217) 398-7721
E-mail: airsupport@greatplanes.com

KIT CONTENTS

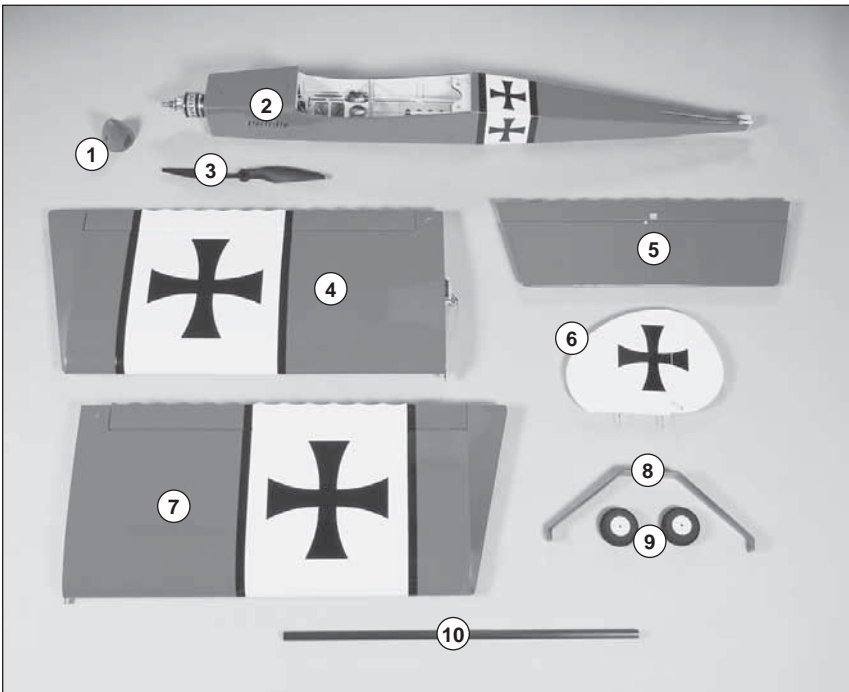

Kit Contents

- | | |
|----|----------------------------------|
| 1 | Spinner |
| 2 | Fuselage |
| 3 | Propeller |
| 4 | Right Wing Panel w/Aileron |
| 5 | Horizontal Stabilizer & Elevator |
| 6 | Vertical Fin & Rudder |
| 7 | Left Wing Panel w/Aileron |
| 8 | Landing Gear |
| 9 | Main Wheels (2) |
| 10 | Carbon Fiber Wing Joiner Tube |

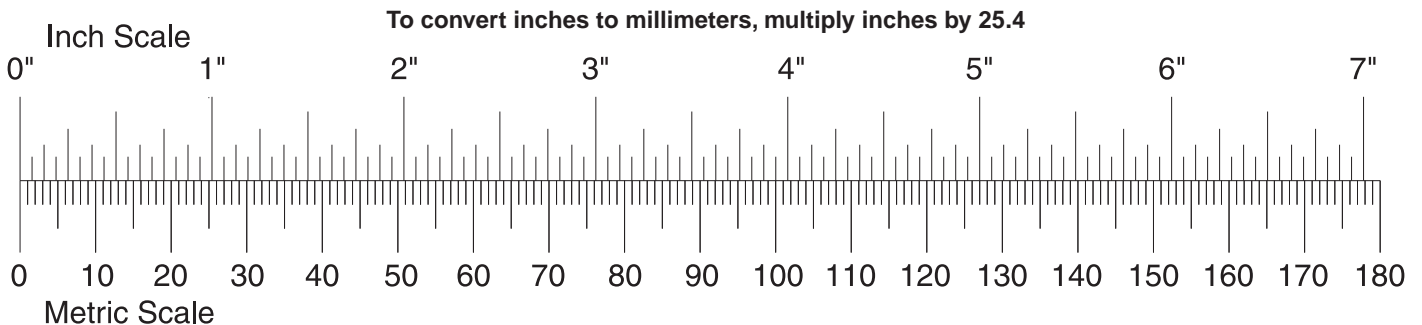

PREPARATIONS

Use a covering iron with a covering sock on medium/high heat to tighten any loose covering if necessary. Apply pressure over sheeted areas to **thoroughly** bond the covering to the wood.

ASSEMBLY

Assemble the Wing

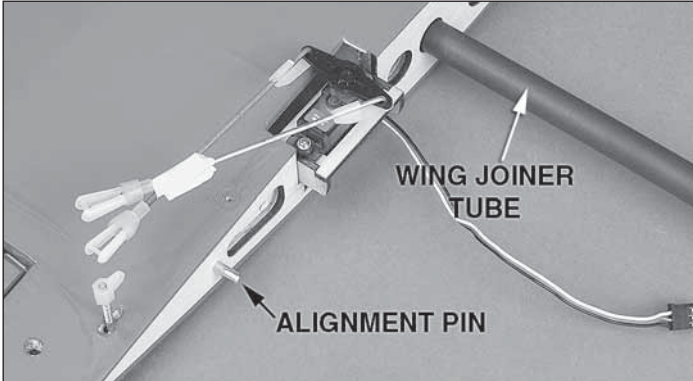

❑ 1. Install the 20-7/8" [530mm] carbon fiber **wing joiner tube** and the 1" [25.4mm] steel **alignment pin** into the **right wing panel** as shown.

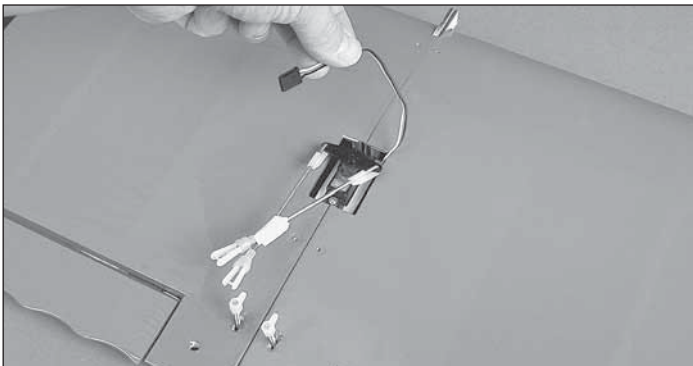

❑ 2. Carefully slide the **left wing panel** in place as shown, making sure that the servo lead does not get pinched.

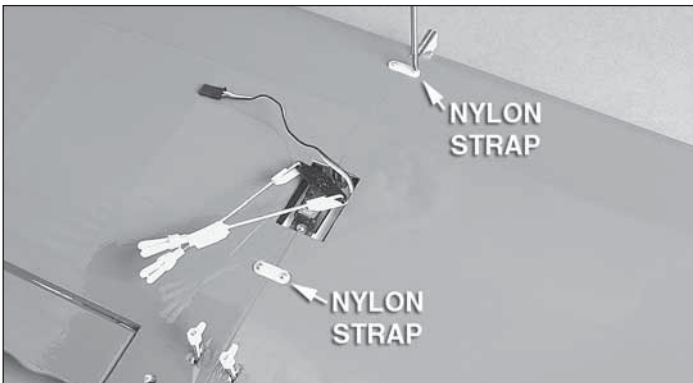

❑ 3. Fasten the wing halves together using the two included nylon straps and four #2 x 3/8" [9.5mm] self-tapping screws as shown.

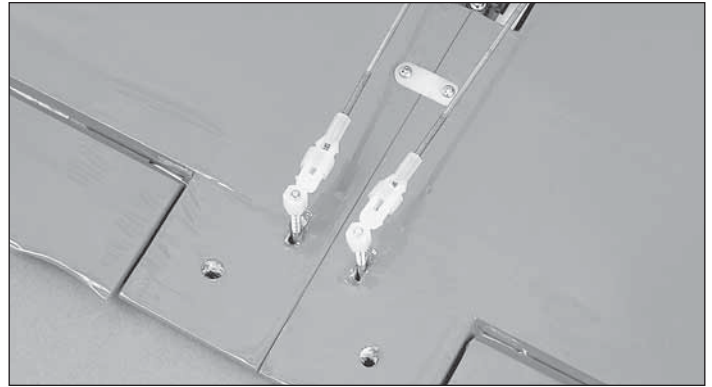

❑ 4. Use your radio system to center the servo. Position the **ailerons** in the neutral position with tape or small clamps and connect the clevises to the aileron torque rod horns. Make any necessary adjustments by threading the clevises up or down the pushrod. When satisfied, slide the silicone clevis retainers to the ends of the clevises.

Wing assembly is complete.

Optional - Dual Aileron Servos

The Great Planes ElectroStik EP RXR comes equipped with **dual aileron servo trays** for dual aileron servos. To install the dual aileron servos, follow these instructions:

For this section you will need:

1	Additional Servo (same type as your existing aileron servo.)	1	Servo Mounting Hardware Set
1	"Y" harness	1	Screwdriver
2	6" [152mm] Pushrods	1	Wire Cutter
2	Nylon Clevises	1	Pliers
2	Silicone Clevis Retainers	1	Thin CA
2	FasLinks	1	Trim Sealing Iron

❑ 1. Disconnect the aileron servo pushrods from the aileron horns and remove the original aileron servo.

❑ 2. Remove the two nylon straps and separate the wing panels.

❑ 3. Locate the dual aileron servo tray in each wing panel. They are located on the underside of the wing at the **4th bay** in from the **wing tip**. Trim the covering over the opening and use a sealing iron to seal the covering to the tray.

❑ 4. Use a 1.5mm [1/16"] drill bit and drill mounting holes for the servos. Insert and then remove a servo mounting screw into each hole and put a drop of thin CA into each hole to harden the threads.

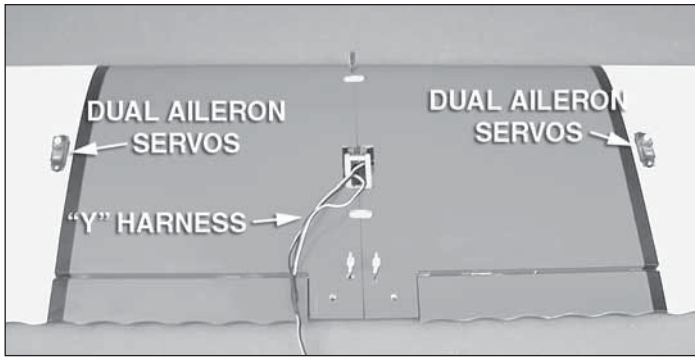

❑ 5. Connect both servos to the “Y” harness. Make sure the “Y” harness exits through the hole in the center of the wing. Use the strings pre-installed inside the wings to pull the servo leads. Install the aileron servos into the trays. Make sure to secure the servo lead/“Y” harness connection with electrical tape or heat shrink tubing. Re-join the wing.

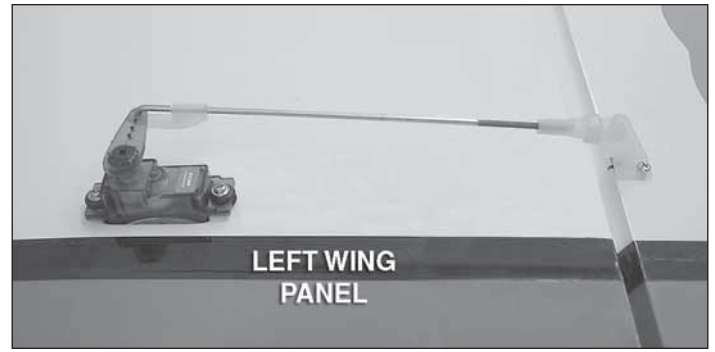

❑ 7. Cut the servo arms as shown above. Use a 6" [152mm] pushrod, a clevis, clevis retainer and FasLink to make each aileron pushrod.

❑ 8. Set-up your new dual servos on your radio to have the same aileron throw as the original airplane. Center the servo arms and install the servo arm screws.

Your dual aileron servo installation is now finished.

Assemble the Fuselage

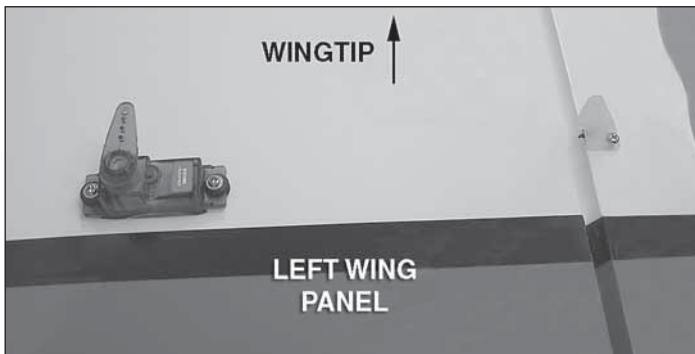
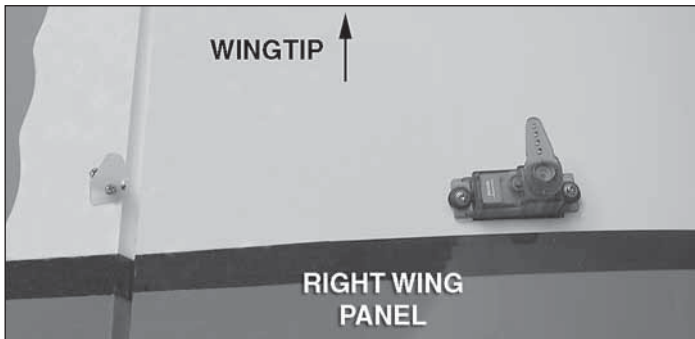

❑ 6. Install the aileron control horns (not included) into the **hardwood blocks** on the ailerons as shown above. Make sure you use thin CA to reinforce the holes in the ailerons.

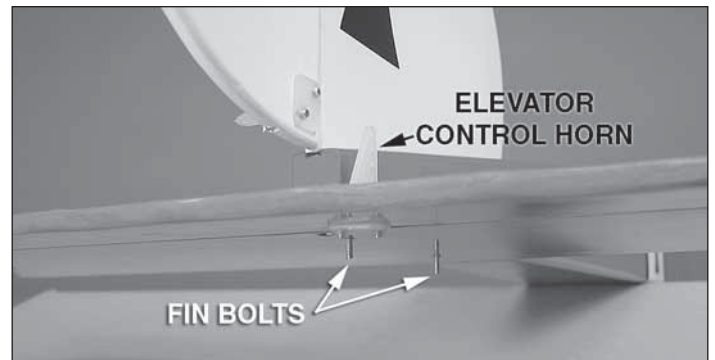

❑ 1. Insert the **vertical fin/rudder assembly** into the slot so that the two fin bolts protrude through the bottom of the fuselage and through the **horizontal stabilizer/elevator assembly** as shown. During installation, make sure that the elevator control horn is toward the top of the airplane.

Note: The fuselage is inverted for the following steps.

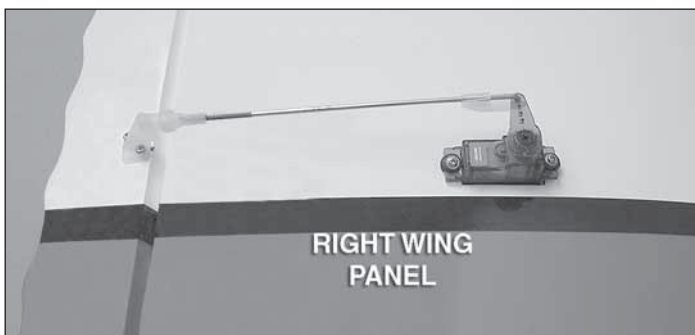

❑ 2. Apply CA or epoxy to the outside of the nylon tail gear bearing and insert it into the hole at the rear of the fuselage by gently tapping it into place until fully seated. Be sure not to get glue into the hole in the bushing.

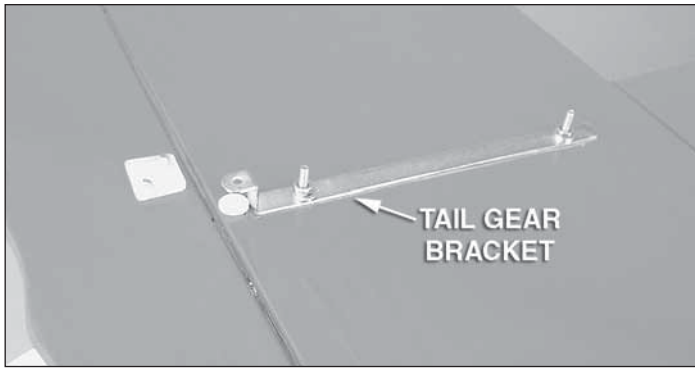

❑ 3. Put the tail gear bracket in place as shown and secure the entire tail assembly with a #2 lock washer and 2mm nut on each bolt. Be certain to tighten the nuts securely, but do not overtighten so as to damage the bottom of the stabilizer. Be sure to use threadlocking cement.

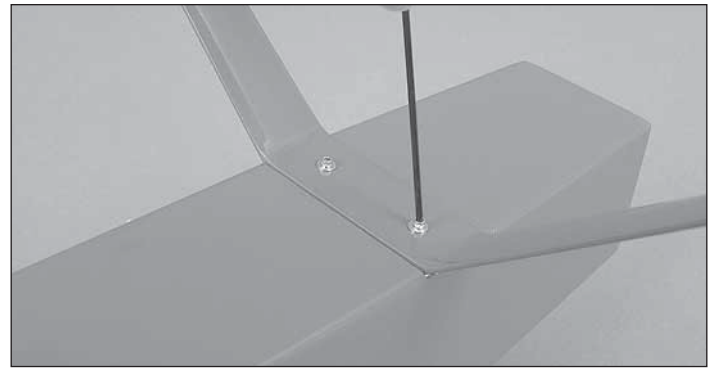

❑ 6. Put the landing gear in place as shown. Using a 3/32" [2.4mm] hex driver, secure the brace with a 4-40 x 1/2" [12.7mm] hex head bolt and #4 washer in each hole. Be sure to use threadlocking cement on each bolt.

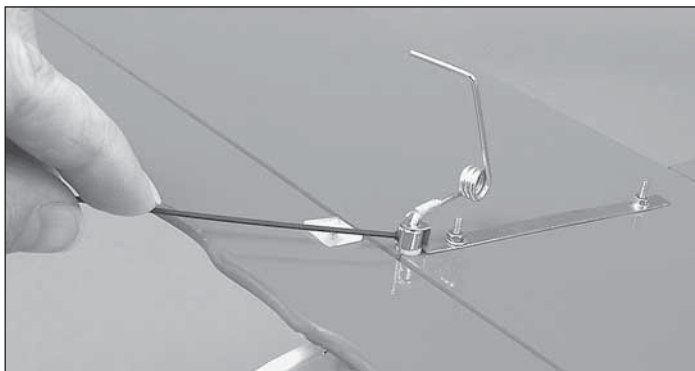

❑ 4. Slide a 3/32" [2.4mm] wheel collar between the nylon tail gear bearing and the tail wheel bracket as shown. Thread the steering wire between the horizontal stabilizer and the elevator as shown and insert the tail wheel assembly through the tail wheel bracket. Secure it by inserting a 4-40 set screw and tightening it with a .050 [1.2mm] hex driver. Be sure to use threadlocking cement on the set screw.

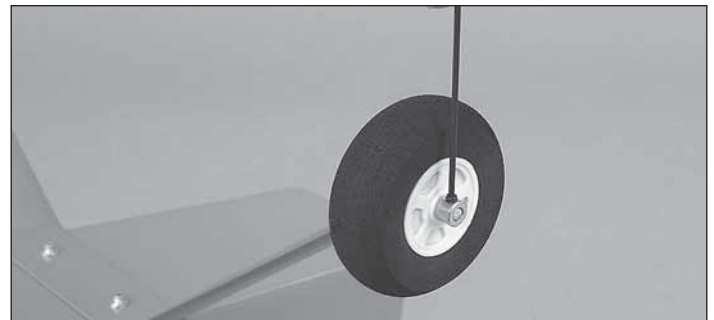

❑ 7. Slide the main wheels onto the axles. Secure them in place by putting a 6-32 set screw in a 5/32" [4mm] wheel collar and tightening it down as shown. Use threadlocking cement on the set screw.

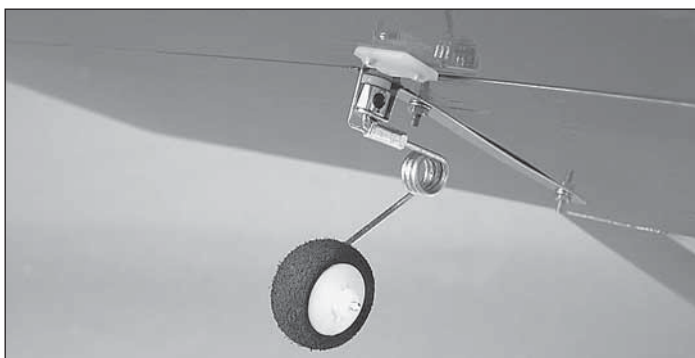

❑ 5. Slide the tail wheel in place on the tail wheel axle. Slide the nylon retainer in place onto the axle and secure it by pressing it into place as shown.

Note: It is a good idea to remove the wheels and wheel collars and grind flat spots on the axles where the set screws made marks from being tightened. A rotary tool such as a Dremel with a cutoff wheel or a metal file can be used to make the flat spots. Then re-install the wheels onto the axles using the wheel collars, set screws, and threadlocking compound. Be sure that the wheels rotate freely. Oil the wheels at the axles if necessary.

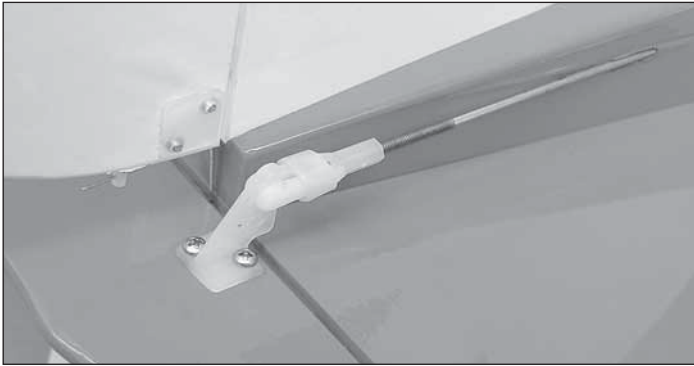

❑ 8. Connect both the elevator and rudder pushrods to their control horns. Use the third-from-the-inner hole in the control horn for both pushrods to obtain the recommended throws. Slide the silicone clevis keeper over the clevis.

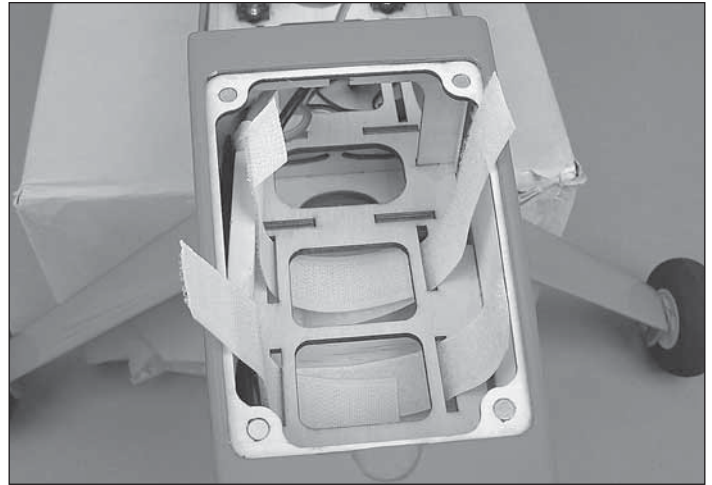

❑ 2. Locate the included segments of hook and loop material and feed the ends through the slots as shown. These will serve to hold your motor battery in place during flight. Be sure to overlap the ends by about 1-1/2" [38mm] underneath the **battery tray**.

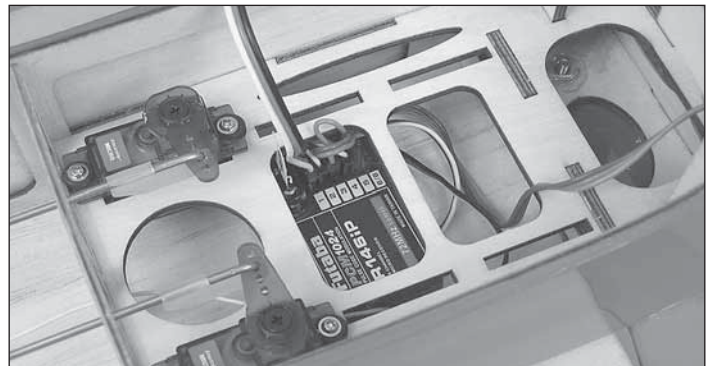

❑ 3. Use hook and loop material or double-sided tape (not included) to secure your receiver inside the fuselage. If you prefer, wrap your receiver in a piece of foam rubber (not included) and strap it into place with tie wraps. Plug the servos into your receiver along with the ESC connector and your 6" [152.4mm] servo extension.

Battery & Radio installation

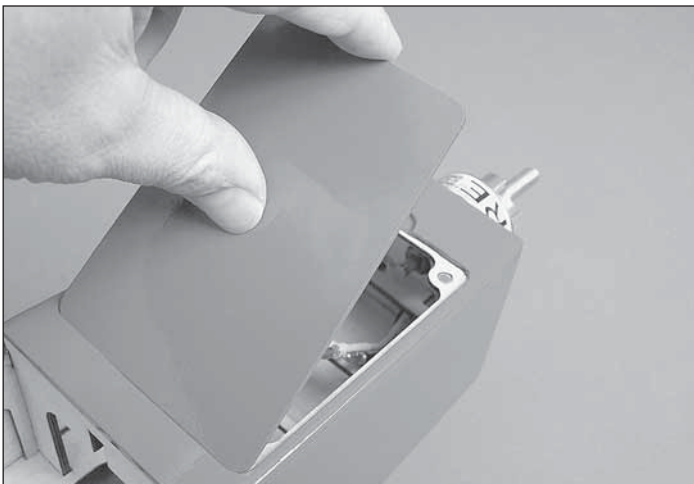

❑ 1. Remove the **battery door** for the following steps. This is done by lifting the front of the door as shown. The battery door is held in place by four small but powerful magnets.

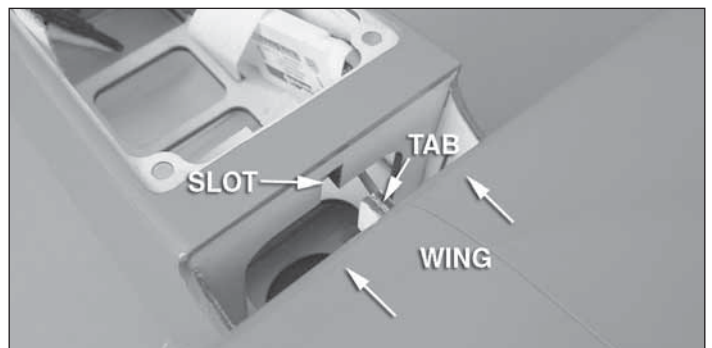

❑ 4. Connect the aileron servo to the aileron extension and slide the tab on the front of the wing into the slot on the fuselage as shown.

GET THE MODEL READY TO FLY

Install & Connect the Motor Battery

Before you can power the radio system and set up the controls, the motor batteries will need to be charged. Charge the batteries and then read the following precautions on how to connect for flying the model.

Check the Control Directions

1. Switch the transmitter "ON" and make sure the throttle stick is down to the off position. Connect the motor battery to the ESC and center the trims. When you hear the "beep", move the throttle stick to full power and you will hear another "beep." Move the throttle back to the "OFF" position and you will hear four "beeps." **CAUTION:** This indicates that the motor is now armed and when you advance the throttle stick, the propeller will begin spinning and thus, propelling the plane forward. If it does not, the throttle reversing switch may be set incorrectly. Disconnect the motor batteries and change the throttle reversing switch. Retry the throttle arming procedure. If the prop is turning the wrong direction (no air blowing back towards the fuselage), disconnect and switch any two of the black wires between the motor and ESC. The ESC will remain armed until you disconnect the motor battery packs. **WARNING! Once the battery is connected to the ESC, stay clear of the propeller even if the ESC has not been armed.**

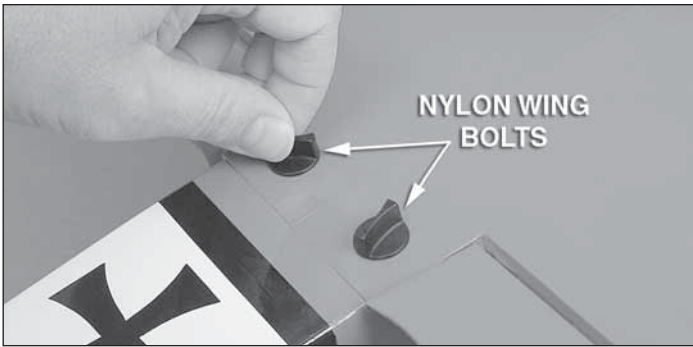

5. Secure the wing by inserting the two 10-24 nylon wing bolts into the wing and tightening them down as shown.

6. Now is a good time to test the rotation of the motor before the prop is installed. Use your radio system and motor battery to temporarily power the motor. **CAUTION:** Though it is highly unlikely that the motor will start, stay away from the propeller once the batteries have been plugged in. Always leave the batteries unplugged unless you are preparing to fly. Assume that whenever the batteries are plugged in that the motor and propeller could start at any time.

Install the Propeller

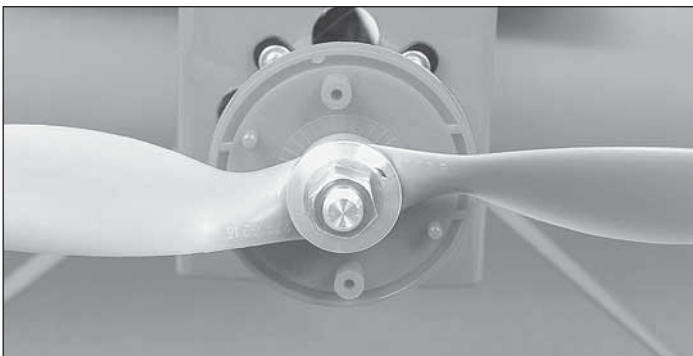

1. Remove the nut and prop washer from the RimFire 42-50-1000kV motor and push the **spinner backplate** all the way onto the motor shaft. The center hole may be enlarged with a prop reamer or drill if necessary. Place the prop on the shaft so that it is perpendicular to the screw hole receptacles as shown. Finger-tighten the prop nut and washer. Hold the prop shaft and tighten the prop nut securely with a prop wrench.

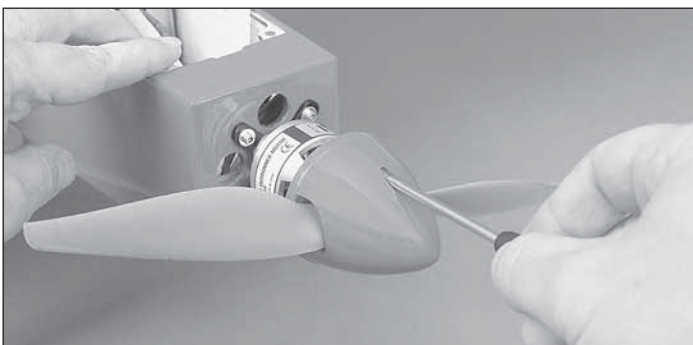

2. Attach the spinner cone to the backplate using the two #4 x 1/2" [12.7mm] screws.

4-CHANNEL RADIO SETUP (STANDARD MODE 2)

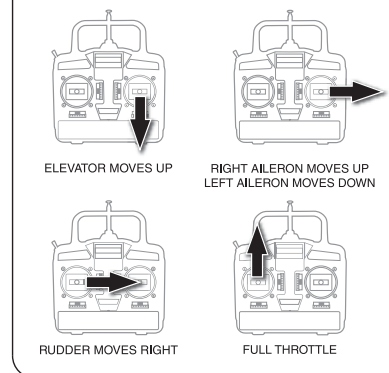

2. Make certain that the control surfaces respond in the correct direction as shown in the diagram. If any of the controls respond in the wrong direction, use the servo reversing in the transmitter to reverse the servos connected to those controls. Be certain the control surfaces have remained centered. Adjust them if necessary.

Set the Control Throws

To ensure a successful first flight, fly your ElectroStik EP RXR set up only according to the C.G. and control surface throws specified in this manual. The throws and C.G. are not arbitrary, but have been determined through extensive testing and accurate record-keeping. This provides you with the best chance for success and enjoyable first flights that should be surprise-free. Additionally, the throws and C.G. shown are true, real data which will allow the model to perform in the manner in which it was intended when flown by a pilot of the skill level for which it was intended. **DO NOT OVERLOOK THESE IMPORTANT PROCEDURES.** A model that is not properly setup may be unstable and possibly unflyable.

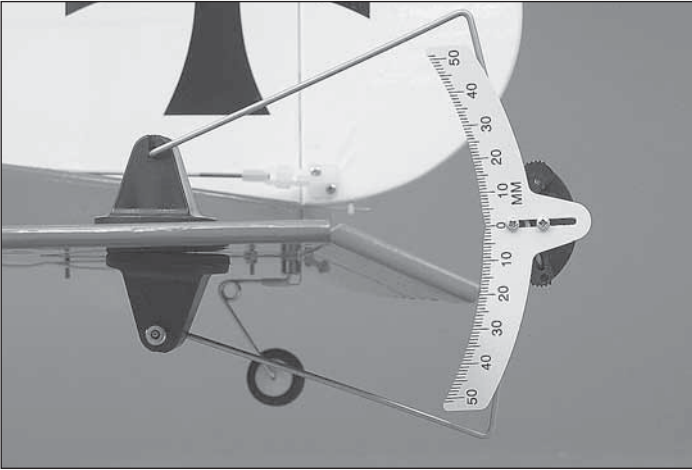

Use a Great Planes AccuThrow (or a ruler) to accurately measure and set the control throw of each control surface as indicated in the chart that follows. If your radio does not have dual rates, we recommend setting the throws at the **low rate** setting. **Note:** The throws are measured at the **widest part** of the elevators, rudder and ailerons.

These are the recommended control surface throws:

	High Rate	Low Rate
ELEVATOR:	1/4" [6.4mm] 10 deg up 1/4" [6.4mm] 10 deg down	1/8" [3.2mm] 5 deg up 1/8" [3.2mm] 5 deg down
RUDDER:	1-1/8" [28.6mm] 50 deg right 1-1/8" [28.6mm] 50 deg left	5/8" [15.9mm] 25 deg right 5/8" [15.9mm] 25 deg left
AILERONS:	1/2" [12.7mm] 20 deg up 1/2" [12.7mm] 20 deg down	3/8" [9.5mm] 15 deg up 3/8" [9.5mm] 15 deg down

Balance the Model (C.G.)

At this stage the model should be in ready-to-fly condition with all of the systems in place including the motor, landing gear, covering, motor battery, and the radio system.

1. Use a felt-tip pen or 1/8" [3mm]-wide tape to accurately mark the C.G. on the bottom of the wing on both sides of the fuselage. The C.G. is located 3-5/8" [92mm] back from the LE of the wing.

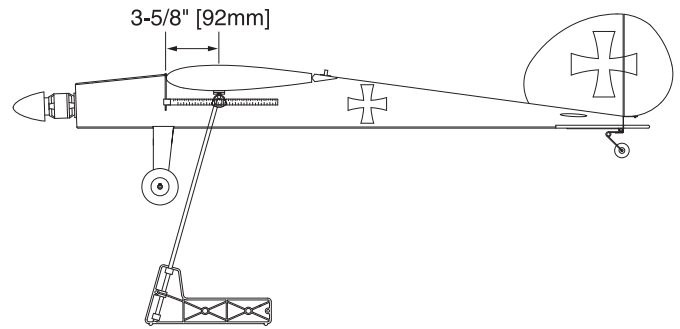

2. With the wing attached to the fuselage, all parts of the model installed (ready to fly) and a motor battery on board, place the model on a Great Planes C.G. Machine, or lift it at the balance point you marked.

3. If the tail drops, the model is "tail heavy" and the battery pack and/or receiver must be shifted forward or weight must be added to the nose to balance. If the nose drops, the model is "nose heavy" and the battery pack and/or receiver must be shifted aft or weight must be added to the tail to balance. If possible, relocate the battery pack and receiver to minimize or eliminate any additional ballast required. If additional weight is required, use Great Planes (GPMQ4485) "stick-on" lead. A good place to add stick-on nose weight is to the firewall. Begin by placing incrementally increasing amounts of weight on the fuselage over the firewall until the model balances. Once you have determined the amount of weight required, it can be permanently attached. If required, tail weight may be added under the stab at the fuselage. **Note:** Do not rely upon the adhesive on the back of the lead weight to permanently hold it in place. Over time, the adhesive may soften and cause the weight to fall off. Use thin CA, RTV silicone or epoxy to permanently hold the weight in place.

4. **IMPORTANT:** If you found it necessary to add any weight, recheck the C.G. after the weight has been installed.

Balance the Model Laterally

1. With the wing level, have an assistant help you lift the model by the engine propeller shaft and the bottom of the fuselage under the TE of the fin. Do this several times.

2. If one wing always drops when you lift the model, it means that side is heavy. Balance the airplane by adding weight to the other wing tip. An airplane that has been laterally balanced will track better in loops and other maneuvers.

PREFLIGHT

Identify Your Model

No matter if you fly at an AMA sanctioned R/C club site or if you fly somewhere on your own, you should always have your name, address, telephone number and AMA number on or inside your model. It is **required** at all AMA R/C club flying sites and AMA sanctioned flying events. Fill out the identification tag on page 16 and place it on or inside your model.

Charge the Batteries

Follow the battery charging instructions that came with your radio control system to charge the batteries. You should always charge your transmitter the night before you go flying, and at other times as recommended by the radio manufacturer.

CAUTION: Unless the instructions that came with your radio system state differently, the **initial** charge on **new** transmitter batteries should be done for 15 hours **using the slow-charger that came with the radio system**. This will "condition" the batteries so that the next charge may be done using the fast-charger of your choice. If the initial charge is done with a fast-charger the batteries may not reach their full capacity and you may be flying with batteries that are only partially charged.

Balance Propellers

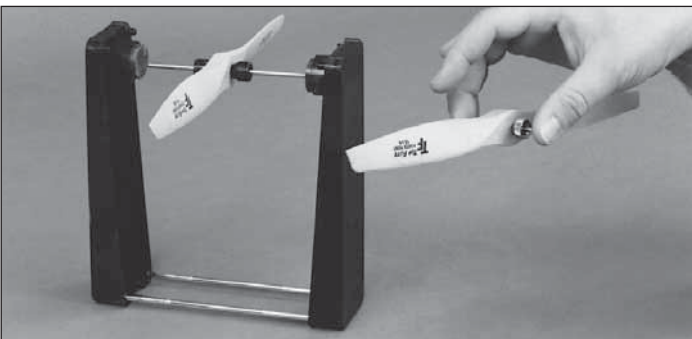

Carefully balance your spare propellers before you fly. An unbalanced prop can be the single most significant cause of vibration that can damage your model. Not only will engine mounting screws and bolts loosen, possibly with disastrous effect, but vibration may also damage your radio receiver and battery. We use a Top Flite Precision Magnetic Prop Balancer (TOPQ5700) in the workshop and keep a Great Planes Fingertip Prop Balancer (GPMQ5000) in our flight box.

Ground Check & Range Check

Always ground check the operational range of your radio before the first flight of the day following the manufacturer's instructions that came with your radio. This should be done once with the motor off and once with the motor running at various speeds. If the control surfaces do not respond correctly, **do not fly!** Find and correct the problem first. Look for loose servo connections or broken wires, corroded wires on old servo connectors, poor solder joints in your battery pack or a defective cell, or a damaged receiver crystal from a previous crash.

MOTOR & BATTERY SAFETY PRECAUTIONS

Failure to follow these safety precautions may result in severe injury to yourself and others.

Always leave the batteries unplugged unless you are preparing to fly. Assume that whenever the batteries are plugged in, the motor and propeller could start at any time. Stay away from the propeller when the motor batteries are plugged in. NEVER have the motor batteries plugged in with the radio system "OFF".

Run the motor outside only and never run the motor in an area of loose gravel or sand; the propeller may throw such material in your face or eyes.

Keep these items away from the prop: loose clothing, shirt sleeves, ties, scarves, long hair or loose objects such as pencils, or screwdrivers that may fall out of shirt or jacket pockets into the prop.

When turning off the system, always disconnect the motor batteries first and then turn the transmitter "OFF".

Once the motor is "armed" always remain behind the arc of the propeller until the batteries are disconnected.

Use safety glasses when running the motor.

Keep your face and body as well as all spectators away from the plane of rotation of the propeller as you run the motor.

LITHIUM BATTERY HANDLING & USAGE

WARNING!! Read the entire instruction sheet included with your battery. Failure to follow all instructions could cause permanent damage to the battery and its surroundings, and cause bodily harm!

- ONLY use a LiPo approved charger. NEVER use a NiCd/ NiMH peak charger!
- NEVER charge in excess of 4.20V per cell.
- ONLY charge through the “charge” or “balance” lead. NEVER charge through the “discharge” lead.
- NEVER charge at currents greater than 1C.
- ALWAYS set charger’s output volts to match battery volts.
- ALWAYS charge in a fireproof location.
- NEVER trickle charge.
- NEVER allow the battery temperature to exceed 150° F [65° C].
- NEVER disassemble or modify pack wiring in any way or puncture cells.
- NEVER discharge below 2.5V per cell.
- NEVER place on combustible materials or leave unattended during charge or discharge.
- ALWAYS KEEP OUT OF REACH OF CHILDREN.
- NEVER leave the LiPo battery unattended while charging. If the battery becomes more than just warm, discontinue charging.
- ALWAYS remove the LiPo battery from the plane before charging.

PROPER CARE OF YOUR MOTOR

Using multiple battery packs to run the motor for successive flights may cause the motor to become excessively hot. We recommend at least a 10-minute motor cool-down period between flights.

AMA SAFETY CODE (excerpts)

Read and abide by the following excerpts from the Academy of Model Aeronautics Safety Code. For the complete Safety Code refer to *Model Aviation* magazine, the AMA web site or the Code that came with your AMA license.

General

- 1) I will not fly my model aircraft in sanctioned events, air shows, or model flying demonstrations until it has been proven to be airworthy by having been previously, successfully flight tested.
- 2) I will not fly my model aircraft higher than approximately 400 feet within 3 miles of an airport without notifying the airport operator. I will give right-of-way and avoid flying in the proximity of full-scale aircraft. Where necessary, an observer shall be utilized to supervise flying to avoid having models fly in the proximity of full-scale aircraft.
- 3) Where established, I will abide by the safety rules for the flying site I use, and I will not willfully and deliberately fly my models in a careless, reckless and/or dangerous manner.
- 5) I will not fly my model unless it is identified with my name and address or AMA number, on or in the model. **Note:** This does not apply to models while being flown indoors.
- 7) I will not operate models with pyrotechnics (any device that explodes, burns, or propels a projectile of any kind).

Radio Control

- 1) I will have completed a successful radio equipment ground check before the first flight of a new or repaired model.
- 2) I will not fly my model aircraft in the presence of spectators until I become a qualified flier, unless assisted by an experienced helper.
- 3) At all flying sites a straight or curved line(s) must be established in front of which all flying takes place with the other side for spectators. Only personnel involved with flying the aircraft are allowed at or in the front of the flight line. Intentional flying behind the flight line is prohibited.
- 4) I will operate my model using only radio control frequencies currently allowed by the Federal Communications Commission.
- 5) **I will not knowingly operate my model within three miles of any pre-existing flying site except in accordance with the frequency sharing agreement listed** (in the complete AMA Safety Code).

9) Under no circumstances may a pilot or other person touch a powered model in flight; **nor should any part of the model other than the landing gear, intentionally touch the ground, except while landing.**

CHECK LIST

During the last few moments of preparation your mind may be elsewhere anticipating the excitement of the first flight. Because of this, you may be more likely to overlook certain checks and procedures that should be performed before the model is flown. To help avoid this, a check list is provided to make sure these important areas are not overlooked. Many are covered in the instruction manual, so where appropriate, refer to the manual for complete instructions. Be sure to check the items off as they are completed.

- 1. Check the C.G. according to the measurements provided in the manual.
- 2. Be certain that the battery and receiver are securely mounted in the fuselage.
- 3. Extend your receiver antenna and make sure it has a strain relief inside the fuselage to keep tension off the solder joint inside the receiver.
- 4. Balance your model *laterally* as explained in the instructions.
- 5. Use threadlocking compound to secure critical fasteners such as the set screws that hold the wheel axles to the struts, etc.
- 6. Add a drop of oil to the axles so the wheels will turn freely.
- 7. Make sure all hinges are **securely** glued in place.
- 8. Reinforce holes for wood screws with thin CA where appropriate (servo mounting screws, etc.).
- 9. Confirm that all controls operate in the correct direction and the throws are set up according to the manual.
- 10. Make sure there are silicone retainers on all the clevises and that all servo arms are secured to the servos with the screws included with your radio.
- 11. Make sure servo wires do not interfere with other systems (servo arms, pushrods, etc.).
- 12. Balance your propeller (and spare propellers).
- 13. Tighten the propeller nut and spinner.
- 14. Place your name, address, AMA number and telephone number on or inside your model.
- 15. If you wish to photograph your model, do so before your first flight.
- 16. Range check your radio when you get to the flying field.

FLYING

The Great Planes ElectroStik EP RXR is a great-flying model that flies smoothly and predictably. The ElectroStik EP RXR does not, however, possess the self-recovery characteristics of a primary R/C trainer and should be flown only by experienced R/C pilots.

CAUTION (THIS APPLIES TO ALL R/C AIRPLANES): If, while flying, you notice an alarming or unusual sound such as a low-pitched "buzz," this may indicate control surface *flutter*. Flutter occurs when a control surface (such as an aileron or elevator) or a flying surface (such as a wing or stab) rapidly vibrates up and down (thus causing the noise). In extreme cases, if not detected immediately, flutter can actually cause the control surface to detach or the flying surface to fail, thus causing loss of control followed by an impending crash. The best thing to do when flutter is detected is to slow the model immediately by reducing power, then land as soon as safely possible. Identify which surface fluttered (so the problem may be resolved) by checking all the servo grommets for deterioration or signs of vibration. Make certain all pushrod linkages are secure and free of play. If it fluttered once, under similar circumstances it will probably flutter again unless the problem is fixed. Some things which can cause flutter are; Excessive hinge gap; Not mounting control horns solidly; Side-play of wire pushrods caused by large bends; Excessive free play in servo gears; Unsecured servo mounting; and one of the most prevalent causes of flutter; Flying an over-powered model at excessive speeds.

Takeoff

Before you get ready to take off, see how the model handles on the ground by doing a few practice runs at low speeds on the runway. Hold "up" elevator to keep the tail wheel on the ground. If necessary, adjust the tail wheel so the model will roll straight down the runway.

Remember to take off into the wind. When you're ready, point the model straight down the runway, hold a bit of up elevator to keep the tail on the ground to maintain tail wheel steering, then gradually advance the throttle. As the model gains speed, decrease up elevator allowing the tail to come off the ground. One of the most important things to remember with a tail dragger is to always be ready to apply right rudder to counteract engine torque. Gain as much speed as your runway and flying site will practically allow before gently applying up elevator, lifting the model into the air. At this moment it is likely that you will need to apply more right rudder to counteract engine torque. Be smooth on the elevator stick, allowing the model to establish a gentle climb to a safe altitude before turning into the traffic pattern.

Flight

For reassurance and to keep an eye on other traffic, it is a good idea to have an assistant on the flight line with you. Tell him to remind you to throttle back once the plane gets to a comfortable altitude. While full throttle is usually desirable for takeoff, most models fly more smoothly at reduced speeds.

Take it easy with the ElectroStik EP RXR for the first few flights, gradually getting acquainted with it as you gain confidence. Adjust the trims to maintain straight and level flight. After flying around for a while, and while still at a safe altitude with plenty of battery power, practice slow flight and execute practice landing approaches by reducing the throttle to see how the model handles at slower speeds. Add power to see how she climbs as well. Continue to fly around, executing various maneuvers and making mental notes (or having your assistant write them down) of what trim or C.G. changes may be required to fine tune the model so it flies the way you like. Mind your fuel level, but use this first flight to become familiar with your model before landing.

Landing

To initiate a landing approach, lower the throttle while on the downwind leg. Allow the nose of the model to pitch downward to gradually bleed off altitude. Continue to lose altitude, but maintain airspeed by keeping the nose down as you turn onto the crosswind leg. Make your final turn toward the runway (into the wind) keeping the nose down to maintain airspeed and control. Level the attitude when the model reaches the runway threshold, modulating the throttle as necessary to maintain your glide path and airspeed. If you are going to overshoot, smoothly advance the throttle (always ready on the right rudder to counteract torque) and climb out to make another attempt. When you're ready to make your landing flare and the model is a foot or so off the deck, smoothly increase up elevator until it gently touches down. Once the model is on the runway and has lost flying speed, hold up elevator to place the tail on the ground, regaining tail wheel control.

One final note about flying your model: Have a goal or flight plan in mind for every flight. This can be learning a new maneuver(s), improving a maneuver(s) you already know, or learning how the model behaves in certain conditions (such as on high or low rates). This is not necessarily to improve your skills (though it is never a bad idea!), but more importantly so you do not surprise yourself by impulsively attempting a maneuver and suddenly finding that you've run out of time, altitude or airspeed. Every maneuver should be deliberate, not impulsive. For example, if you're going to do a loop, check your altitude, mind the wind direction (anticipating rudder corrections that will be required to maintain heading), remember to throttle back at the top, and make certain you

are on the desired rates (high/low rates). A flight plan greatly reduces the chances of crashing your model just because of poor planning and impulsive moves. **Remember to think.**

Have a ball! But always stay in control and fly in a safe manner.

GOOD LUCK AND GREAT FLYING

This model belongs to:	_____
	Name

	Address

City, State Zip	

Phone number	

AMA number	

Make a copy of this identification tag and put it on or inside your model.