

PT-17 STEARMAN ARF

INSTRUCTION MANUAL



Wingspan: Top Wing: 71.5 in [1815mm]
Bottom Wing: 69 in [1755mm]
Wing Area: Top Wing: 762 sq in [49.1 dm²]
Bottom Wing: 704 sq in [45.4 dm²]
Weight: 14.5 – 15.5 lb [6580 – 7030 g]
Wing Loading: 23 – 24 oz/sq ft [69-74 g/dm²]
Length: 57 in [1450mm]
Radio: 4-channel with 5 servos
Engine: .91-1.08 cu in [15-17.5cc] two-stroke,
.91-1.20 cu in [19.5-23cc] four-stroke

WARRANTY

Great Planes® Model Manufacturing Co. guarantees this kit to be free from defects in both material and workmanship at the date of purchase. This warranty does not cover any component parts damaged by use or modification. **In no case shall Great Planes' liability exceed the original cost of the purchased kit.** Further, Great Planes reserves the right to change or modify this warranty without notice.

In that Great Planes has no control over the final assembly or material used for final assembly, no liability shall be assumed nor accepted for any damage resulting from the use by the user of the final user-assembled product. By the act of using the user-assembled product, the user accepts all resulting liability.

If the buyer is not prepared to accept the liability associated with the use of this product, the buyer is advised to return this kit immediately in new and unused condition to the place of purchase.

To make a warranty claim, send the defective part or item to Hobby Services at this address.

Hobby Services
3002 N. Apollo Dr., Suite 1
Champaign, IL 61822
USA

Include a letter stating your name, return shipping address, as much contact information as possible (daytime telephone number, fax number, e-mail address), a detailed description of the problem and a photocopy of the purchase receipt. Upon receipt of the package the problem will be evaluated as quickly as possible.

READ THIS MANUAL BEFORE STARTING CONSTRUCTION. IT CONTAINS IMPORTANT INSTRUCTIONS AND WARNINGS CONCERNING THE ASSEMBLY AND USE OF THIS MODEL.



Champaign, IL
(217) 398-8970, Ext. 5
airsupport@greatplanes.com

TABLE OF CONTENTS

INTRODUCTION	2
IMAA	2
SAFETY PRECAUTIONS	2
ADDITIONAL ITEMS REQUIRED	3
Hardware & Accessories	3
Adhesives & Building Supplies	3
Optional Supplies & Tools	4
IMPORTANT BUILDING NOTES	4
KIT INSPECTION	5
METRIC CONVERSIONS	6
ORDERING REPLACEMENT PARTS	6
IMPORTANT INFORMATION ABOUT WORKING WITH FIBERGLASS	6
PREPARATIONS	7
BUILD THE WING	7
Installing the Ailerons	7
Join the Wing	7
Install the Aileron Servos & Pushrods	8
BUILD THE FUSELAGE	11
Preparations	11
Install the Stab, Elevator, Fin & Rudder	11
Attach the Wing & Cabanes	13
Build the Carry Handle	15
Install the Engine & Throttle Servo	17
Install the Cowl & Dummy Radial Engine	18
Install the Fuel Tank	21
Assemble the Nose Weight Box	21
Install the Wheels	22
Install the Radio System	23
Finishing Touches	26
Optional Flying Wire Installation	26
Apply the Decals	29
GET THE MODEL READY TO FLY	30
Check the Control Directions	30
Set the Control Throws	30
Balance the Model (C.G.)	31
Balance the Model Laterally	31
PREFLIGHT	31
Identify Your Model	31
Charge the Batteries	31
Balance the Propellers	32
Ground Check	32
Range Check	32
ENGINE SAFETY PRECAUTIONS	32
AMA SAFETY CODE (excerpts)	32
IMAA SAFETY CODE (excerpts)	33
CHECK LIST	33
FLYING	34
Fuel Mixture Adjustments	34
Take Off	34
Flight	34
Landing	35

INTRODUCTION

The PT-17 Military Stearman ARF has a long and colorful history in both military and civilian use. You will thoroughly enjoy the wide range of capabilities of this plane as well as its good looks. We think you will be pleased with the attention to detail and its flight characteristics. For the latest technical updates or manual corrections to the PT-17 Military Stearman ARF, visit the Great Planes web site at www.greatplanes.com. Open the "Airplanes" link, then select the PT-17 Military Stearman ARF. If there is new technical information or changes to this model a "tech notice" box will appear in the upper left corner of the page.

IMAA

The PT-17 Military Stearman ARF is an excellent sport-scale model and is eligible to fly in IMAA events. The IMAA (International Miniature Aircraft Association) is an organization that promotes non-competitive flying of giant-scale models. If you plan to attend an IMAA event, obtain a copy of the **IMAA Safety Code** by contacting the IMAA at the address or telephone number below, or by logging on to their web site at www.fly-ima.org/ima/sanction.html.

IMAA

205 S. Hilldale Road
Salina, KS 67401
(913) 823-5569

PROTECT YOUR MODEL, YOURSELF & OTHERS...FOLLOW THESE IMPORTANT SAFETY PRECAUTIONS

1. Your PT-17 Military Stearman ARF should not be considered a toy, but rather a sophisticated, working model that functions very much like a full-size airplane. Because of its performance capabilities, the PT-17 Military Stearman ARF, if not assembled and operated correctly, could possibly cause injury to yourself or spectators and damage to property.

2. You must assemble the model **according to the instructions**. Do not alter or modify the model, as doing so may result in an unsafe or unflyable model. In a few cases the instructions may differ slightly from the photos. In those instances the written instructions should be considered as correct.

3. You must take time to **build straight, true and strong**.

4. You must use an R/C radio system that is in first-class condition, and a correctly sized engine and components (fuel tank, wheels, etc.) throughout the building process.

5. You must correctly install all R/C and other components so that the model operates correctly on the ground and in the air.

6. You must check the operation of the model before **every** flight to insure that all equipment is operating and that the model has remained structurally sound. Be sure to check clevises or other connectors often and replace them if they show any signs of wear or fatigue.

7. If you are not already an experienced R/C pilot, you should fly the model only with the help of a competent, experienced R/C pilot.

8. While this kit has been flight tested to exceed normal use, if the plane will be used for extremely high stress flying, such as racing, the modeler is responsible for taking steps to reinforce the high stress points.

9. **WARNING:** The cowl and wing struts included in this kit are made of fiberglass, the fibers of which may cause eye, skin and respiratory tract irritation. Never blow into a part to remove fiberglass dust, as the dust will blow back into your eyes. Always wear safety goggles, a particle mask and rubber gloves when grinding, drilling and sanding fiberglass parts. Vacuum the parts and the work area thoroughly after working with fiberglass parts.

Note: We, as the kit manufacturer, provide you with a top quality kit and great instructions, but ultimately the quality of your finished model depends on how you build it; therefore, we cannot in any way guarantee the performance of your completed model, and no representations are expressed or implied as to the performance or safety of your completed model.

Remember: Take your time and follow the instructions to end up with a well-built model that is straight and true.

If you have not flown this type of model before, we recommend that you get the assistance of an experienced pilot in your R/C club for your first flights. If you're not a member of a club, your local hobby shop has information about clubs in your area whose membership includes experienced pilots.

In addition to joining an R/C club, we strongly recommend you join the AMA (Academy of Model Aeronautics). AMA membership is required to fly at AMA sanctioned clubs. There are over 2,500 AMA chartered clubs across the country. Among other benefits, the AMA provides insurance to its members who fly at sanctioned sites and events. Additionally, training programs and instructors are available at AMA club sites to help you get started the right way. Contact the AMA at the address or toll-free phone number that follows.



Academy of Model Aeronautics
5151 East Memorial Drive
Muncie, IN 47302
Tele: (800) 435-9262
Fax (765) 741-0057
Or via the Internet at:
<http://www.modelaircraft.org>

ADDITIONAL ITEMS REQUIRED

Hardware & Accessories

This is the list of hardware and accessories required to finish the PT-17 Military Stearman ARF. Order numbers are provided in parentheses.

Engine (refer to the engine size requirements on the cover of the manual)

4-Channel radio

- (1) standard servo (throttle)
- (4) servos with minimum of 54 oz/in torque (2-ailerons, 1-elevator, 1-rudder)
- (2) 12" [300mm] servo extensions (for aileron servos, HCAM2711 for Futaba®)
- (1) Y-harness (for aileron servos, HCAM2751 or Futaba)
- (1) minimum 1,000mAh receiver battery

Propeller and spare propellers (refer to your engine manufacturer's recommendations)

- 2" [600mm] large, silicone fuel tubing (GPMQ4133)

Adhesives & Building Supplies

In addition to common household tools and hobby tools, this is the "short list" of the most important items required to build the PT-17 Military Stearman ARF. **Great Planes Pro™ CA and Epoxy glue are recommended.**

- R/C foam rubber (1/4" [6mm] – HCAQ1000, or 1/2" [13mm] – HCAQ1050)
- 1 oz. [30g] Thin Pro CA (GPMR6002)
- 1 oz. [30g] Medium Pro CA+ (GPMR6008)
- Pro 30-minute epoxy (GPMR6047)
- Pro 6-minute epoxy (GPMR6045)
- Drill bits: 1/16" [1.6mm], 5/64" [2mm], 3/32" [2.4mm], 1/8" [3mm], #29 or 9/64" [3.6mm], 3/16" [4.8mm],
- 3 pkgs Stick-on segmented lead weights (GPMQ4485)
- #1 Hobby knife (HCAR0105)
- #11 Blades (5-pack, HCAR0211)
- Small T-pins (100, HCAR5100)
- R/C-56 canopy glue (JOZR5007)
- CA applicator tips (HCAR3780)
- Denatured alcohol (for epoxy cleanup)

- Flat black fuelproof paint (for cockpit)
- 8-32 Tap (GPMR8103)
- 8-32 Tap Handle (GPMR8120)

Optional Supplies & Tools

Here is a list of optional tools mentioned in the manual that will help you build the PT-17 Military Stearman ARF.

- 2 oz. [57g] spray CA activator (GPMR6035)
- or -
- 4 oz. [113g] aerosol CA activator (GPMR634)
- Epoxy brushes (6, GPMR8060)
- Mixing sticks (50, GPMR8055)
- Mixing cups (GPMR8056)
- Builder's Triangle Set (HCAR0480)
- Curved-tip canopy scissors for trimming plastic parts (HCAR0667)
- Pliers with wire cutter (HCAR0630)
- Robart Super Stand II (ROBP1402)
- Hobbico® Duster™ can of compressed air (HCAR5500)
- Masking tape (TOPR8018)
- Microballoons (TOPR1090)
- Threadlocker™ thread-locking cement (GPMR6060)
- Denatured alcohol (for epoxy clean up)
- Rotary tool such as Dremel®
- Rotary tool reinforced cut-off wheel (GPMR8200)
- Servo horn drill (HCAR0698)
- Dead Center™ Engine Mount Hole Locator (GPMR8130)
- AccuThrow™ Deflection Gauge (GPMR2405)
- CG Machine™ (GPMR2400)
- Precision Magnetic Prop Balancer™ (TOPQ5700)
- Fuel filler valve for glow fuel (GPMQ4160)

IMPORTANT BUILDING NOTES

There are two types of screws used in this kit:

Sheet metal screws are designated by a number and a length.



This is a number six screw that is 3/4" long.

Machine screws are designated by a number, **threads per inch**, and a length – for example, 4-40 x 3/4".



This is a number four screw that is 3/4" long with forty threads per inch.

- When you see the term **test fit** in the instructions, it means that you should first position the part on the

assembly **without using any glue**, then slightly modify or *custom fit* the part as necessary for the best fit.

- Whenever the term **glue** is written you should rely upon your experience to decide what type of glue to use. When a specific type of adhesive works best for that step, the instructions will make a recommendation.
- Whenever just **epoxy** is specified you may use **either** 30-minute (or 45-minute) epoxy **or** 6-minute epoxy. When 30-minute epoxy is specified it is **highly** recommended that you use only 30-minute (or 45-minute) epoxy, because you will need the working time and/or the additional strength.
- **Photos** and **sketches** are placed **before** the step they refer to. Frequently you can study photos in following steps to get another view of the same parts.
- The PT-17 Military Stearman ARF is factory-covered with Top Flite® MonoKote® film. Should repairs ever be required, MonoKote can be patched with additional MonoKote purchased separately. MonoKote is packaged in six-foot rolls, but some hobby shops also sell it by the foot. If only a small piece of MonoKote is needed for a minor patch, perhaps a fellow modeler would give you some. MonoKote is applied with a model airplane covering iron, but in an emergency a regular iron could be used. A roll of MonoKote includes full instructions for application. Following are the colors used on this model and order numbers for six foot rolls.

Cub Yellow – TOPQ0220
 Dove Gray – TOPQ0211
 Sky Blue – TOPQ0206
 True Red – TOPQ0227

- The stabilizer and wing incidences and engine thrust angles have been factory-built into this model. However, some technically minded modelers may wish to check these measurements anyway. To view this information visit the web site at www.greatplanes.com and click on "Technical Data." Due to manufacturing tolerances which will have little or no effect on the way your model will fly, please expect slight deviations between your model and the published values.

KIT INSPECTION

Before starting to build, take an inventory of this kit to make sure it is complete, and inspect the parts to make sure they are of acceptable quality. If any parts are missing or are not of acceptable quality, or if you need assistance with assembly, contact **Great Planes Product Support**. When reporting defective or missing parts, use the part names exactly as they are written in the Kit Contents list on this page.

Great Planes Product Support:
Telephone: (217) 398-8970, ext. 5
Fax: (217) 398-7721
E-mail: airsupport@greatplanes.com

Parts Layout

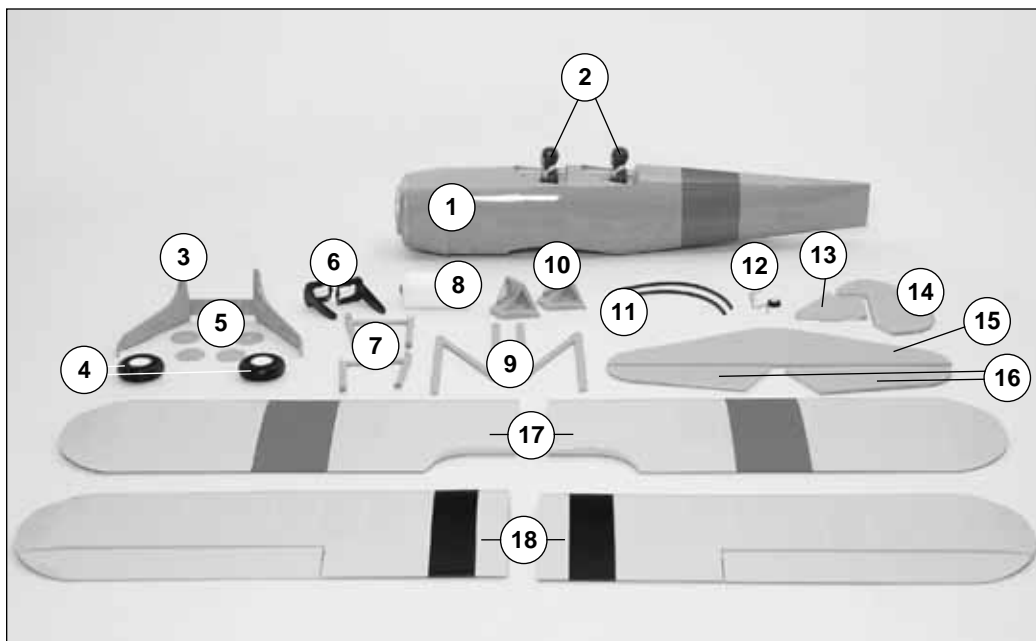

Kit Contents

1. Fuselage
2. Pilots (2)
3. Main Landing Gear
4. Wheels (2)
5. Wheel Covers (4)
6. Engine Mount
7. Center Cabanes (2)
8. Fuel Tank
9. "N" Struts (2)
10. Windscreens (2)
11. Cockpit Coaming (2 pcs)
12. Tail Wheel Assembly
13. Vertical Fin
14. Rudder
15. Horizontal Stab
16. Elevator
17. Top Wing Panels (L&R)
18. Bottom Wing Panels (L&R w/Ailerons)

Parts Not Photographed

	Qty		Qty		Qty
4-40 Threaded Metal Clevis	4	#4 x 1/2" SMS	4	.074 x 17-1/2" Pushrod Wire	1
3/16" x 2" Axle	2	6-32 x 1/4" SHCS	6	.074 x 36" Pushrod Wire.....	3
Screw-Lock Pushrod Connector	1	4-40 x 1/8" Set Screw.....	1	.074 x 6" Pushrod Wire.....	4
4-40 Blind Nuts	20	4-40 x 1/4" SHCS	1	#4 Lock Washers	16
4-40 Nuts	4	#2 x 3/8" SMS	28	#4 Flat Washer	24
8-32 Blind Nuts	9	8-32 x 3/4" SHCS	5	#2 Flat Washer	10
5/16-24 Axle Nut.....	2	4-40 x 1/2" SHCS	16	#8 Lock Washers	8
1/4-20 Blind Nut	2	4-40 x 1/2" Phillips Head M/S	8	#8 Flat Washer	8
4-40 Nylon Lock Nuts	8	#2 x 3/8" Wood Screw	8	4-40 x 3/4" SHCS	4
Large Nylon Control Horn	7	8-32 x 1-1/4" SHCS	4	Dummy Radial Engine	1
Small Nylon Control Horn.....	4	8-32 x 1" SHCS	4		
1/4-20 Nylon Bolt	2	#2 x 1/2" SMS	4		
Nylon Clevis	7	#4 x 1" MS	4		
Nylon Retainer	1	3/32" Wheel Collar	1		
2" x 9" Hinge Material.....	1	5/32" Wheel Collar	2		
FasLink	7	3/16" Wheel Collar	4		
Clevis Retainer	11	1-1/4" Tail Wheel.....	1		

METRIC CONVERSIONS

1" = 25.4mm (conversion factor)

1/64" = .4 mm	3/4" = 19.0 mm
1/32" = .8 mm	1" = 25.4 mm
1/16" = 1.6 mm	2" = 50.8 mm
3/32" = 2.4 mm	3" = 76.2 mm
1/8" = 3.2 mm	6" = 152.4 mm
5/32" = 4.0 mm	12" = 304.8 mm
3/16" = 4.8 mm	18" = 457.2 mm
1/4" = 6.4 mm	21" = 533.4 mm
3/8" = 9.5 mm	24" = 609.6 mm
1/2" = 12.7 mm	30" = 762.0 mm
5/8" = 15.9 mm	36" = 914.4 mm

ORDERING REPLACEMENT PARTS

Replacement parts for the PT-17 Military Stearman ARF are available using the order numbers in the Replacement Parts List that follows. The fastest, most economical service can be provided by your hobby dealer or mail-order company. Parts may also be ordered directly from Hobby Services, but full retail prices and shipping and handling charges will apply. Illinois and Nevada residents will also be charged sales tax.

To locate a hobby dealer, visit the Great Planes web site at www.greatplanes.com. Choose "Where to Buy" at the bottom of the menu on the left side of the page. Follow the instructions provided on the page to locate a U.S., Canadian or International dealer. If a hobby shop is not available, replacement parts may also be ordered from Tower Hobbies at www.towerhobbies.com, or by calling toll free (800) 637-6050, or from Hobby Services by calling (217) 398-0007, or via facsimile at (217) 398-7721. If ordering via fax, include a Visa® or MasterCard® number and expiration date for payment.

Mail parts orders and payments by personal check to:

Hobby Services
3002 N Apollo Drive, Suite 1
Champaign IL 61822

Be certain to specify the order number exactly as listed in the **Replacement Parts List**. Payment by credit card or personal check only; no C.O.D.

If additional assistance is required for any reason, contact the appropriate Product Support by e-mail or by telephone at (217) 398-8970.

productsupport@greatplanes.com

REPLACEMENT PARTS LIST

Order Number	Description	How to Purchase
GPMA2800	Top Wing Set	Hobby Supplier
GPMA2801	Bottom Wing Set	Hobby Supplier
GPMA2802	Fuselage Kit	Hobby Supplier
GPMA2803	Tail Surface Set	Hobby Supplier
GPMA2804	Landing Gear	Hobby Supplier
GPMA2805	Cowl	Hobby Supplier
GPMA2806	Dummy Radial Eng.	Hobby Supplier
GPMA2807	Pilot	Hobby Supplier
GPMA2808	Wheel Covers	Hobby Supplier
GPMA2809	Windscreens	Hobby Supplier
GPMA2810	Cabane Set	Hobby Supplier
GPMA2811	Interplane Strut Set	Hobby Supplier
GPMA2812	Decal Sheets	Hobby Supplier
GPMA2473	Metal Brackets	Hobby Supplier
GPMZ0198	Instruction Manual	Product Support
	Missing pieces	Product Support
	Full-size plans	Not Available

IMPORTANT INFORMATION ABOUT WORKING WITH FIBERGLASS

If you have never worked with fiberglass there are a few basic things you should be aware of.

1. When you are cutting into fiberglass, be sure you are cutting the correct place. Unlike wood, you are not able to go back and easily fix a mistake.
2. Whenever you are gluing a part to the inside of fiberglass it is important to roughen the inside surface of the fiberglass with 220-grit sandpaper, then wipe the area with alcohol. The molding process leaves a waxy residue that can prevent a good bond between the glue and the parts being glued.
3. If you do not have a high-speed rotary tool such as a Dremel tool, you should consider purchasing one or borrowing one from a fellow modeler. This combined with a fiberglass cut-off wheel is going to be extremely helpful in the assembly process.

WARNING: The cowl included in this kit is made of fiberglass, the fibers of which may cause eye, skin and respiratory tract irritation. Never blow into a part to remove fiberglass dust, as the dust will blow back into your eyes. Always wear safety goggles, a particle mask and rubber gloves when grinding, drilling and sanding fiberglass parts. Vacuum the parts and the work area thoroughly after working with fiberglass parts.

PREPARATIONS

1. If you have not done so already, remove the major parts of the kit from the box and inspect for damage. If any parts are damaged or missing, contact Product Support at the address or telephone number listed in the “*Kit Inspection*” section on page 5.
2. Remove the tape and separate the ailerons and flaps from the wing and the elevators from the stab. Use a covering iron with a covering sock on high heat to tighten the covering if necessary. Apply pressure over sheeted areas to **thoroughly** bond the covering to the wood.

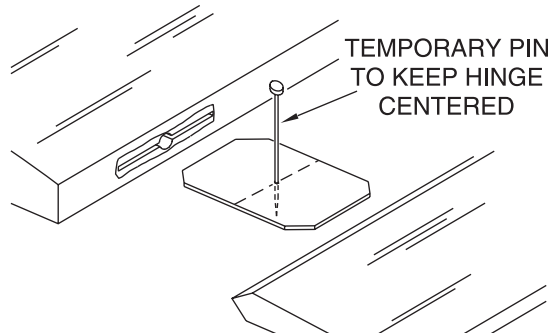

4. Test fit the ailerons to the wing with the hinges. If the hinges don't remain centered, stick a pin through the middle of the hinge to hold it in position.
5. Remove any pins you may have inserted into the hinges. Adjust the aileron so there is a small gap between the LE of the aileron and the wing. The gap should be small, just enough to see light through or to slip a piece of paper through.



6. Apply six drops of thin CA to the top and bottom of each hinge. Do not use CA accelerator. After the CA has fully cured, test the hinges by pulling on the aileron.
7. Repeat steps 1- 6 for the **left bottom wing panel**.

BUILD THE WING

Installing the Ailerons

Do the right bottom wing first so your work matches the photos the first time through. You can do one wing at a time, or work on them together.

1. On the **right bottom wing panel**, drill a 3/32" [2.4mm] hole, 1/2" [13mm] deep in the center of each hinge slot to allow the CA to “wick” in. Follow-up with a #11 blade to clean out the slots. **Hint:** If you have one, use a high-speed rotary tool to drill the holes.

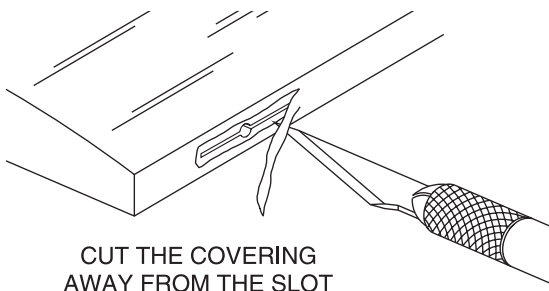

2. Use a sharp #11 blade to cut a strip of covering from the hinge slots in the **wing** and **aileron**.
3. Cut seventeen 3/4" x 1" [19 x 25mm] **hinges** from the **CA hinge strip**. Snip off the corners so they go in easier.

Join the Wing



1. Cut away the covering from the servo bay in the bottom of the **right bottom wing panel**.

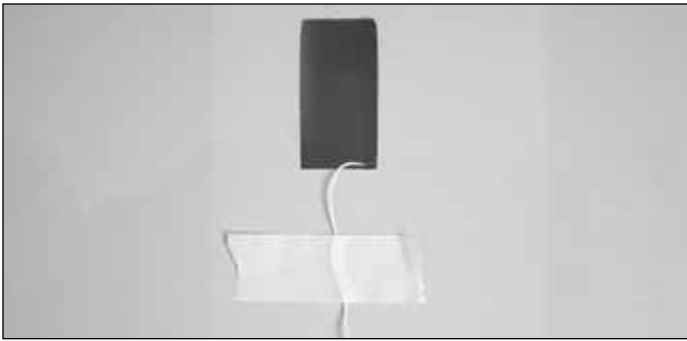

2. A string is taped inside the servo bay. Carefully remove the string from the servo bay and tape it to the outside of the wing to prevent it from dropping back into the wing. The other end of the string is taped to the root rib. Remove the tape, thread the string through the small hole in the top of the wing and tape it to the wing.

3. Repeat steps 1 and 2 for the **left bottom wing panel**.

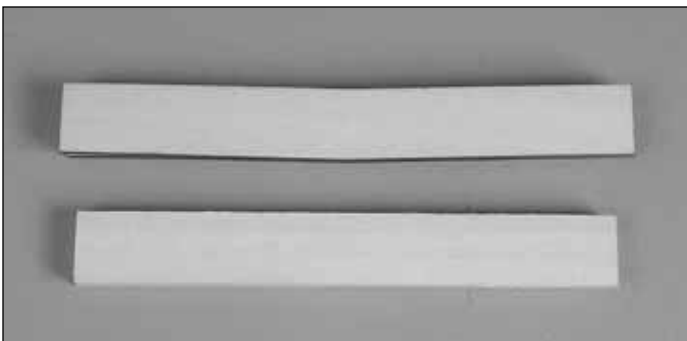
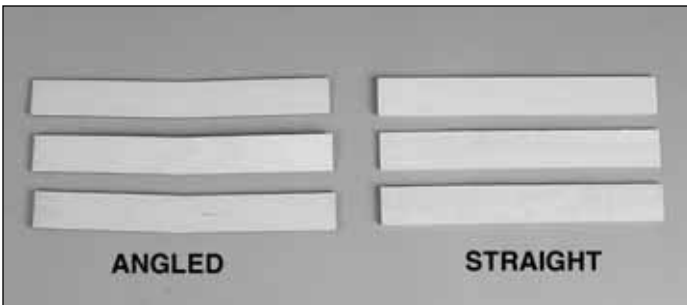

4. Locate three 1/8" [3mm] **straight plywood wing joiners** and three 1/8" [3mm] **angled plywood wing joiners**. Using 6-minute epoxy, glue the straight ones together to form one 3/8" [9.5mm] **straight wing joiner** and glue the three angled ones together forming the 3/8" [9.5mm] **angled wing joiner**.

5. After the glue has cured, test fit the angled wing joiner into the bottom wing panels and the straight wing joiner into the top wing panels. Sand the joiners as needed to get a good fit.

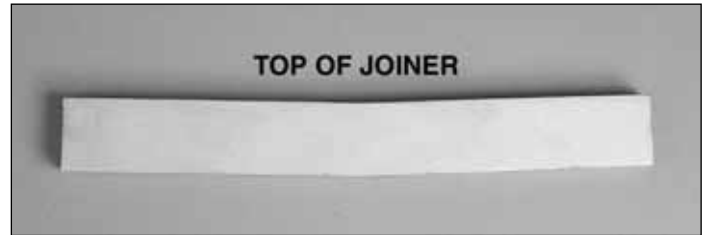

6. When you are satisfied with the fit of the joiners, glue the angled joiner into the bottom wing panels with 30-minute epoxy. Be sure that the top of the joiner is towards the top of the wing. When gluing the wing panels together be sure to get glue into the joiner pockets in the wing. This can be done by applying the glue into the pocket with a small stick. Apply glue to the pocket, the joiner and the root rib of the wing.

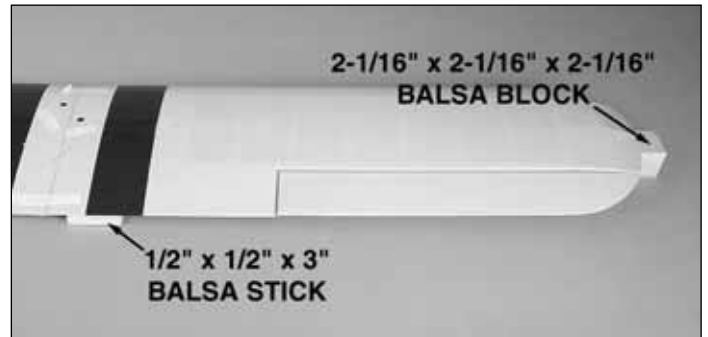

Before the glue cures, set one wing half flat on your bench. Insert the 1/2" x 1/2" x 3" [13 x 13 x 76mm] balsa **block** under the **trailing edge** of the wing that sits flat on the workbench. Block up the **wing tip** of the other wing half with the 2-1/16" x 2-1/16" x 2-1/16" [52 x 52 x 52mm] balsa **block** included in the kit. Put small weights on the wing half that is flat on the bench to keep it lying flat and leave the block under the wing tip of the other wing half while the glue cures.

7. Hold the wing together with masking tape while the glue is curing. Excess epoxy can be cleaned away with denatured alcohol and a paper towel.

8. Glue the top wing together using the straight wing joiner and following the same gluing procedure used on the bottom wing. **Note:** There is no dihedral on the top wing. After gluing the wing together be sure it remains flat on the workbench while the glue cures.

Install the Aileron Servos & Pushrods

1. On the right lower wing, install a 12" [305mm] **servo extension** onto the servo lead. Secure the extension to the lead with tape, a piece of heat-shrink tube or some other method to keep them from coming unplugged.

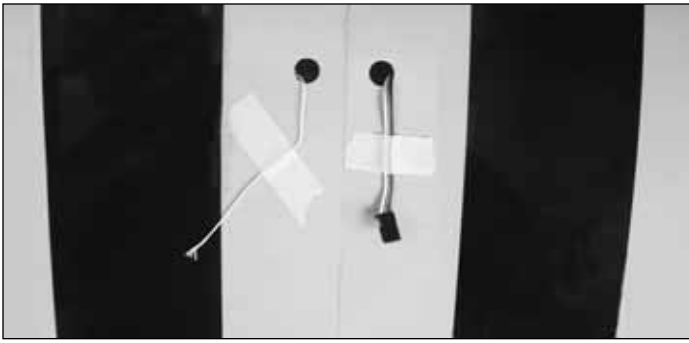

2. Tie the string to the servo extension. At the root of the wing the other end of the string is taped. Pull the string and the servo lead through the wing. Untie the string from the lead and insert the lead through the small hole you cut the covering from. Tape the lead to the wing to prevent it from falling back into the wing.



3. Install the **servo** into the servo opening. Drill through the servo mounting holes with a 1/16" [1.6mm] drill bit. Remove the servo from the servo opening. Install and then remove a servo mounting screw into each of the holes you have drilled. Apply a drop of thin CA into the holes to harden the threads. Once the glue has cured, install the servo into the servo opening using the hardware included with your servo. Center the servo, then install a **servo arm** as shown. The arm should be pointing towards the wing tip.

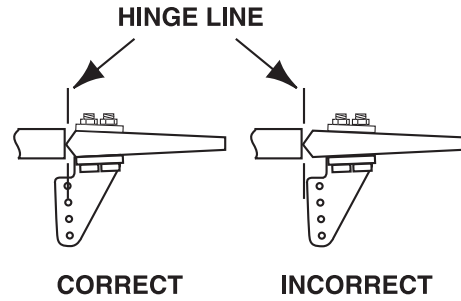
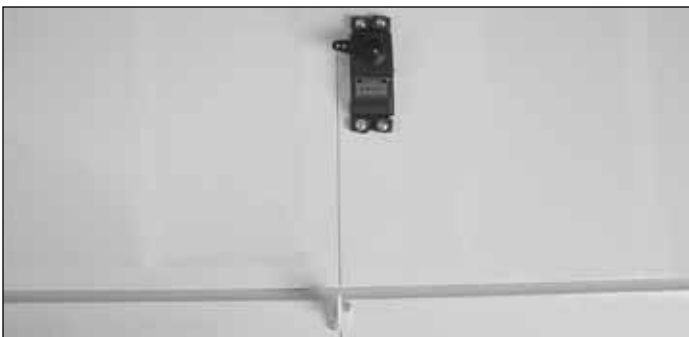

4. Place a nylon **clevis** in line with the last hole in the servo arm. When positioned properly the **control horn** will rest on a plywood **plate** in the aileron. Mark the location of the mounting holes onto the aileron. Drill a 1/16" [1.6mm] hole on the marks, drilling through the plywood plate but not through the top of the aileron. Insert and remove a #2 x 3/8" [9.5mm] screw into each of the holes. Apply a couple drops of thin CA into the holes to harden the threads. Once the glue has cured attach the horn to the aileron with two #2 x 3/8" [9.5mm] screws.

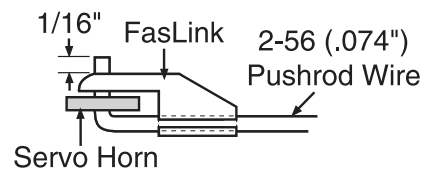
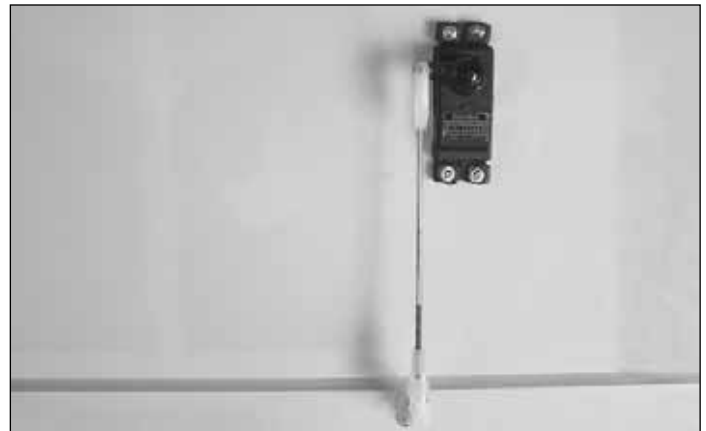

5. Thread a nylon clevis onto a .074 x 6" [152mm] threaded wire 20 turns. Slide a silicone **clevis retainer** onto the clevis. Install the clevis into the second hole from the end of the control horn, then slide the silicone retainer over the clevis. Drill a 5/64" [2mm] hole in the outer hole of the servo arm. Center the servo and the aileron. With a fine-tip marker, mark the wire where it aligns with the outer hole of the servo arm. Make a 90° bend on the mark. Cut the wire so the wire is 3/8" [9.5mm] in length after the bend. Insert the wire into the servo arm and lock it in place with a nylon **FasLink**.

6. Repeat steps 1-5 for the left wing panel.

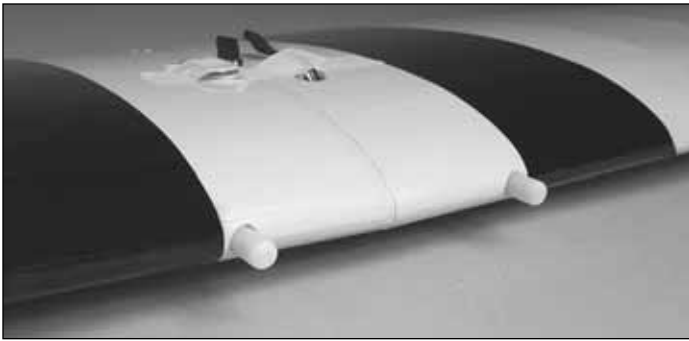

7. On the bottom wing, cut the covering away from the holes in the leading edge of the wing for the nylon **wing dowels**. Glue them in place with 6-minute epoxy. Wipe any excess epoxy away with denatured alcohol. When properly positioned the wing dowels should extend approximately 3/8" [9.5mm] beyond the leading edge of the wing.

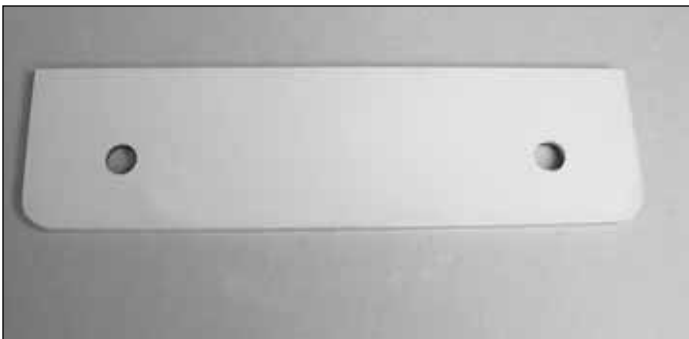

8. Cut the covering from the holes on the plywood **wing bolt plate**.



9. Cut the covering from the holes at the wing trailing edge on both the **top** and **bottom** of the wing.

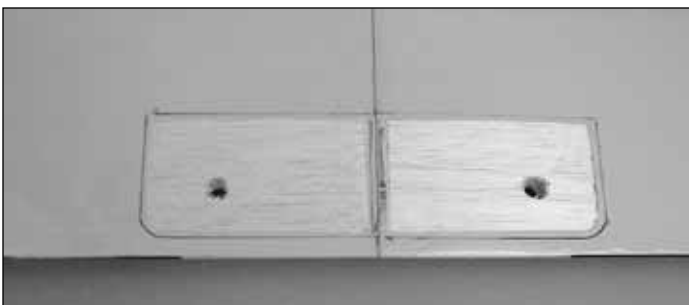

10. Place the wing bolt plate in position over the holes in the bottom wing. Use the nylon **wing bolts** to help you align the holes in the plate with the holes in the wing. Trace the outline of the plate onto the covering with a felt-tip pen. Use a sharp #11

blade and refer the "**Expert Tip**" that follows to cut the covering inside the lines you have drawn. Use caution not to cut through the surface of the wing skin. Remove the covering.



HOW TO CUT COVERING FROM Balsa



Use a soldering iron to cut the covering from the stab. The tip of the soldering iron doesn't have to be sharp, but a fine-tip does work best. Allow the iron to heat fully. Use a straightedge to guide the soldering iron at a rate that will just melt the covering and not burn into the wood. The hotter the soldering iron, the faster it must travel to melt a fine cut. Peel off the covering.



11. Glue the wing bolt plate to the wing using epoxy. Use small clamps to hold the wing bolt plate in position while the glue cures.

BUILD THE FUSELAGE

Preparations

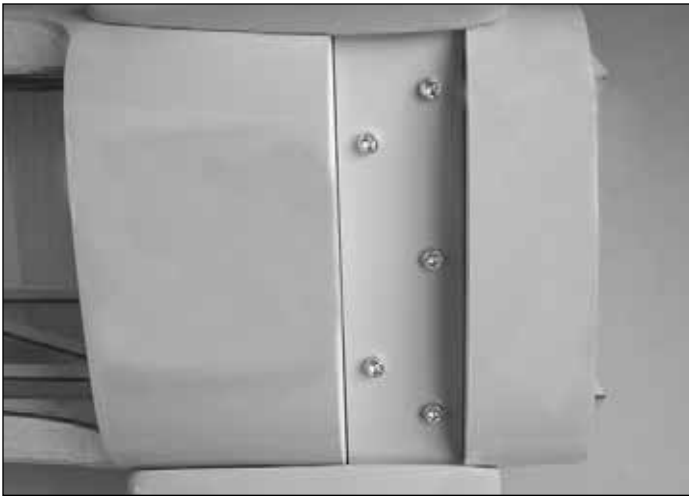

1. Remove the **belly pan** from the bottom of the **fuselage**. Install the **landing gear** to the fuselage with five 8-32 x 3/4" [19mm] socket head cap screws. Apply a drop of Threadlocker to each bolt before installing them.

2. Glue the belly pan back in place with a few dabs of silicone glue. Using silicone will allow you to remove the belly pan easily should you ever have to get access to the landing gear bolts.

We will come back and do the installation of the wheels later. Having the landing gear installed at this time will make it easier to handle the fuselage on the workbench.

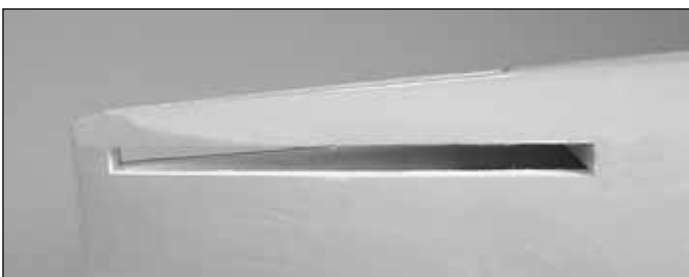

3. Cut the covering from the fuselage where the **horizontal stabilizer** fits into the fuselage.



4. Cut the covering and the wood **block** from the back of the **horizontal stabilizer saddle**.

Install the Stab, Elevator, Fin & Rudder

1. Temporarily attach the lower wing to the fuselage with the 1/4-20 nylon bolts. Slide the horizontal stabilizer into the slot in the fuselage. Stand back and look at the stab in relation to the wing. The stab should be parallel with the wing. If not, sand the stab saddle until the stab and wing are aligned.

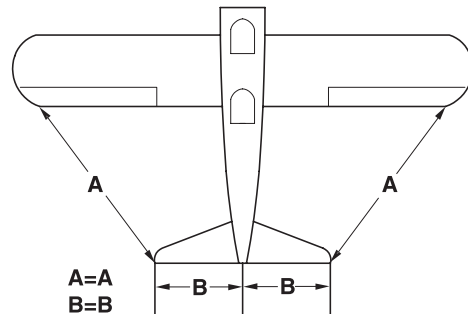
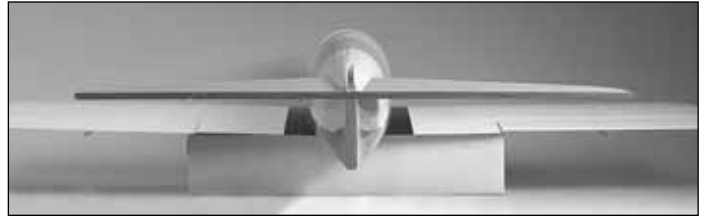

2. Measure the distance from the tip of the stab to the tip of each wing. Adjust the position of the stab until they are equal.



3. Using a felt-tip pen, mark the outline of the fuselage on the top and the bottom of the stab.



4. Cut the covering on the top and bottom of the stab inside the lines you have drawn. Use the same technique for removing the covering from the wing.

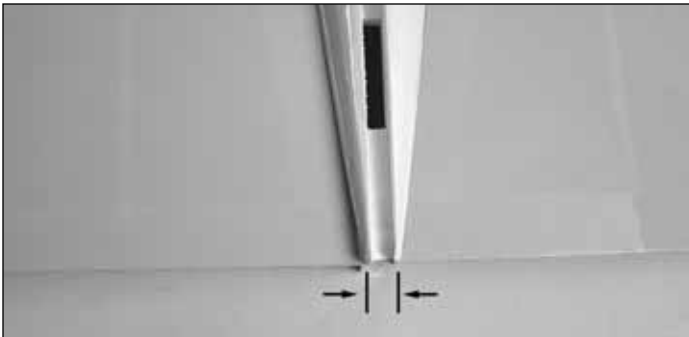
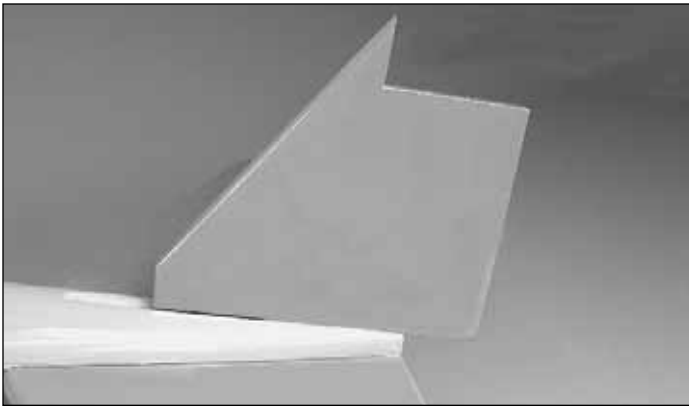

❑ 5. Glue the stab in place with 30-minute epoxy. Excess epoxy can be cleaned away with a paper towel and denatured alcohol. After the stab is positioned and all excess epoxy has been cleaned away, temporarily install the **vertical fin** part of the way into the slot. Just put it into place enough to verify that you have not pushed the wood **fuselage fairings** too close together and that the slot in the stab is aligned with the opening for the fin. Remove the fin and allow the glue to cure. If any glue has gotten on the fin, remove it with denatured alcohol.

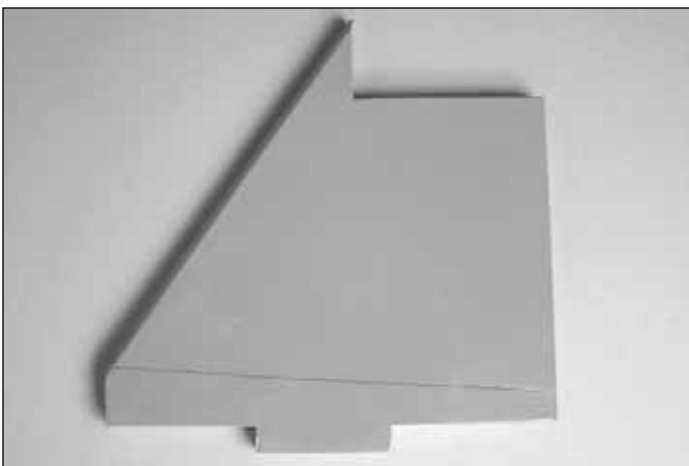

❑ 6. Remove the bottom wing from the fuselage. Temporarily install the fin into the slot in the top of the fuselage. Using a fine-point felt-tip pen, mark the outline of the fuselage onto the fin. Cut the covering from the fin using the same method described earlier.

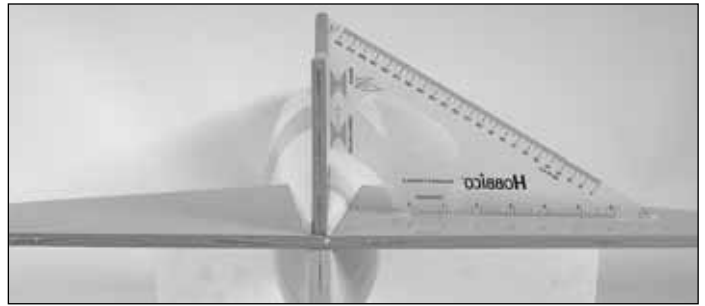

❑ 7. Test fit the fin into the fuselage. Check to be sure the fin is perpendicular to the stab. If it is not, sand the side of the fin to make minor adjustments. Once you are satisfied with the fit, glue the fin to the fuselage with epoxy.

❑ 8. Using the same installation method used previously, install three hinges into each **elevator half**. Then install the **elevators** into the stab. Glue the hinges using thin CA.

***Did you know?...**Built as a private venture by the Stearman Aircraft Company of Wichita (bought by Boeing in 1934), this two-seat biplane was of mixed construction. The wings were of wood with fabric covering while the fuselage had a tough, welded steel framework, also fabric covered. In 1936, the Army tentatively bought 26 airframes from Boeing (the Model 75), which the Army named the PT-13. With war on the horizon, this trickle of acquisition soon turned into a torrent; 3519 were delivered in 1940 alone.*

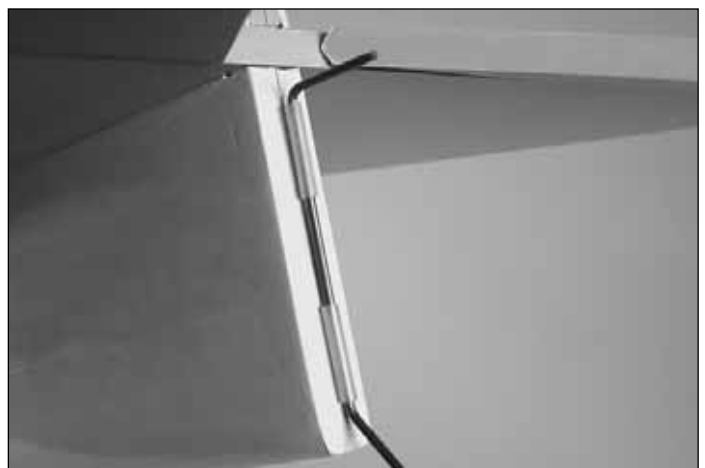
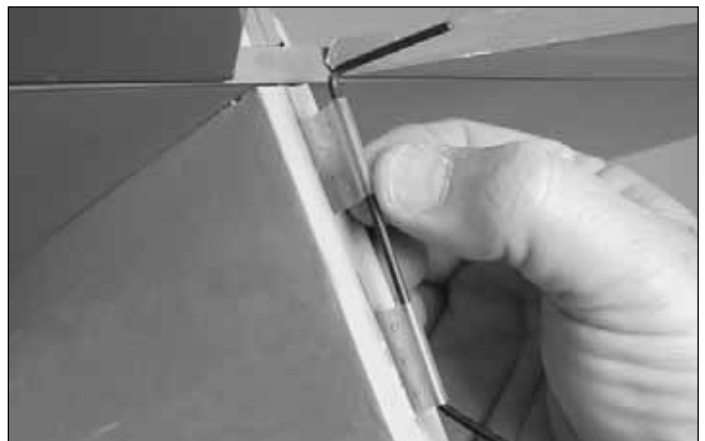

❑ 9. Locate the **tailwheel wire**. Test fit it into the two slots in the back of the fuselage. Use your hobby knife to clean

out the slots if it is too tight. Once satisfied with the fit, remove the wire from the slots. Apply a couple of drops of oil to the wire where it passes through the nylon bearings. This will prevent glue from getting onto the wire. Apply epoxy to the nylon tabs and then install the tailwheel wire into the fuselage.

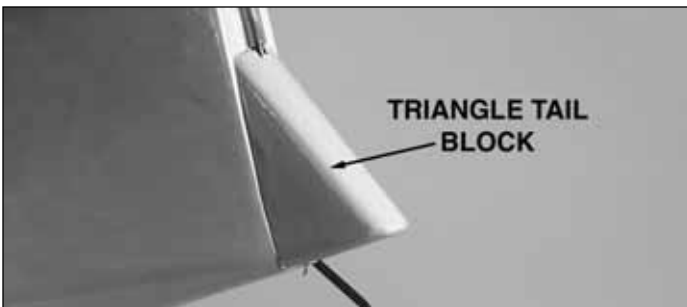
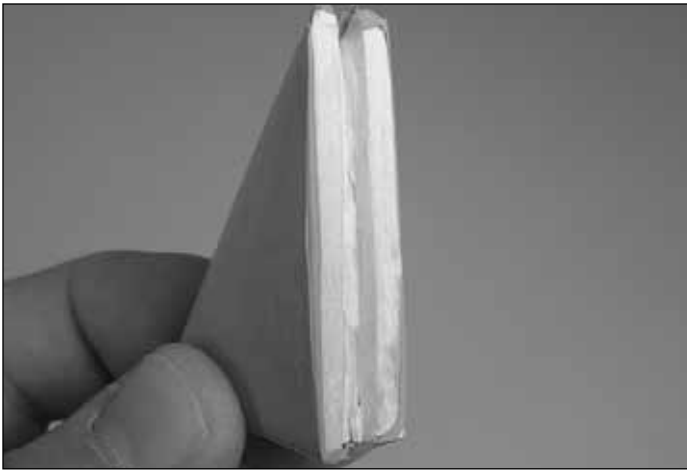

10. Cut the covering from the front of the balsa **triangle tail block**. Cut the covering from the back of the fuselage where the block will be glued to the fuselage. Test fit the block over the landing gear wire. Make adjustments to the slot in the block as needed. Glue the block to the fuselage. Be careful not to get glue on the wire.



11. Cut the covering from the hole on the leading edge, bottom of the **rudder**. Test fit the hinges into the rudder and

then fit the rudder to the fin and fuselage. Make any adjustments that may be needed to the slot in the rudder. When you are satisfied everything fits well, put a small amount of epoxy into the hole in the rudder, install the hinges in the rudder and install the rudder to the fin.

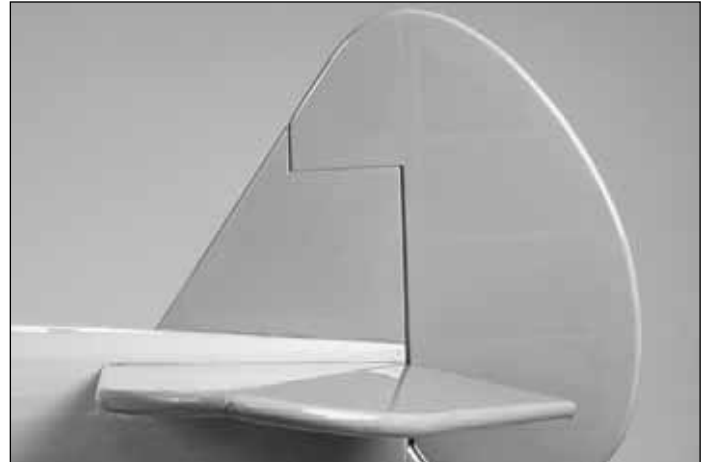

12. Glue the hinges to the fin and rudder with thin CA.

Attach the Wing & Cabanes

1. Attach the lower wing to the fuselage with the 1/4-20 nylon bolts.

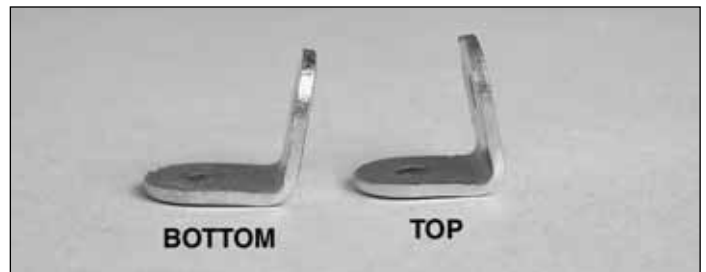

2. Locate eight metal **cabane mounting brackets**. The photograph identifies the correct bracket for the top and bottom wing. Set the four brackets for the top wing to the side. We will be installing the brackets on the bottom wing first.

Do the right wing first so your work matches the photos the first time through.



3. Look closely on the top of the bottom wing and you will find a small pin hole locating the blind nuts for the cabane mounting bolts. Cut the covering from each of the

holes. **Note:** 4-40 Blind nuts have been installed in the wing for all of the cabane mounting bolts. All of the blind nuts are glued into the wing and have a small wood **plate** backing them up. It is possible that a blind nut could have a bit of glue in the threads. In most cases the installation of the bolt should free the glue. If not, run a 4-40 tap through the threads to clear the glue.

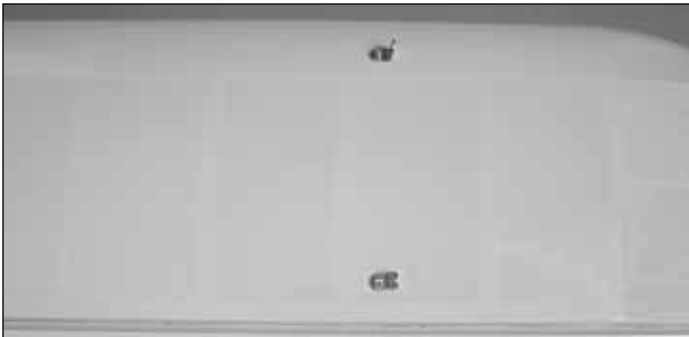

4. Mount the **bottom wing cabane brackets** in each of the holes in the right wing panel with a 4-40 x 1/2" [13mm] socket head cap screw and a #4 lock washer. Do not fully tighten the bracket to the wing yet.

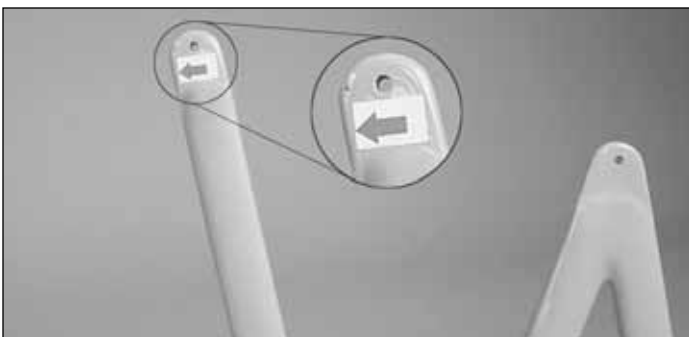

5. Position the "N" **strut** to the bracket. Located on the strut is a piece of masking tape with an arrow that indicates the top, front of the strut.

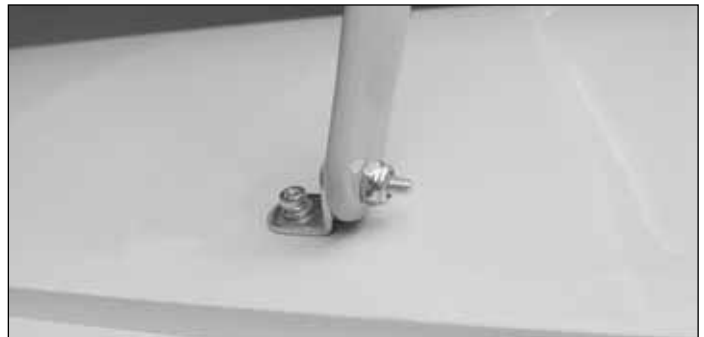

6. Attach the strut to the bracket as shown with a 4-40 x 1/2" [13mm] phillips head screw, a #4 washer and a 4-40 nylon lock nut.

7. If you have not been doing the bracket installation on both the right and left wing, go back and repeat steps 3-6 for the left wing panel.

8. Locate the pin holes and cut the covering from the blind nuts in the bottom of the top wing. Four are located in the center of the wing and two are located at each end of the wing.

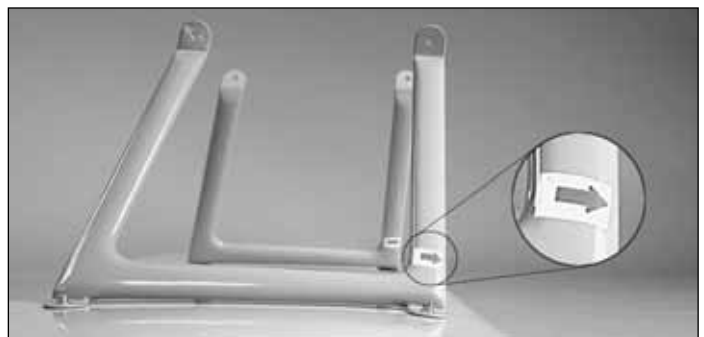
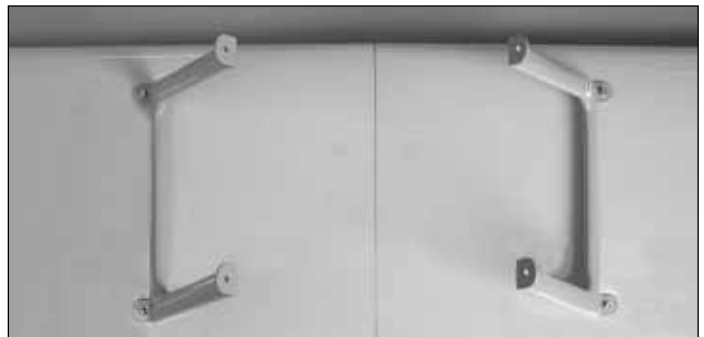

9. Install the **center cabanes** with 4-40 x 1/2" [13mm] socket head cap screws and #4 lock washers. Be sure you mount the cabanes as shown with the arrows pointed towards the wing leading edge.

❑ 10. Install the four remaining brackets in the blind nuts at the ends of the wing.

❑ 11. Place the top wing onto the "N" struts. Attach the top wing to the "N" struts with 4-40 x 1/2" [13mm] phillips head screws, #4 washers and 4-40 nylon lock nuts the same way you installed the strut to the lower brackets.



❑ 12. Set the fuselage on the firewall. Look at the relation of the top wing to the bottom wing. Be sure the top wing is parallel with bottom wing. Adjust the top wing as needed. Then carefully set the fuselage back on the landing gear.

❑ 13. Without disturbing the top wing, push a T-pin into the fuselage through each of the cabane mounting holes. Push the pin hard to verify that the mounting holes are positioned over the **hardwood rails**. If you do not find hardwood and only hit balsa wood, check to see if you have mounted the center cabanes properly. If you have the center cabanes backwards they will not align over the hardwood rails.

❑ 14. Drill a 5/64" [2mm] hole through each of the four mounting holes in the center cabanes. When you drill these holes you must be drilling into the hardwood rails located in the fuselage.

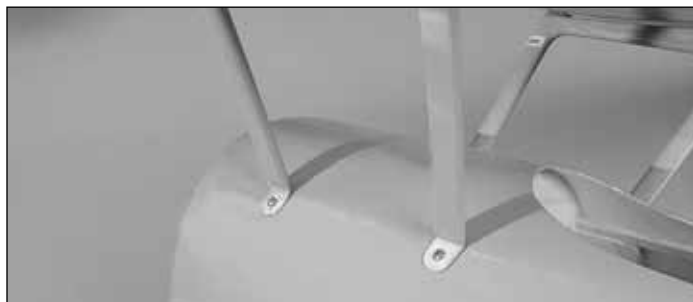

❑ 15. Install and then remove a #4 x 1/2" [13mm] sheet metal screw into each of the four holes. Apply a couple drops of thin CA into each of the holes to harden the threads. After the glue has cured, permanently install the screws into the fuselage.

Did you know?...*The PT-17 Military Stearman gained a reputation as a rugged airplane and a good teacher. Officially named the Boeing Model 75, the plane was (and still is) persistently known as the "Stearman" by many who flew them. It was called the "PT" by the Army, "N2S" by the Navy and "Kaydet" by Canadian forces. By whatever name, more than 10,000 were built by the end of 1945 and at least 1,000 are still flying today worldwide.*

Build the Carry Handle

This kit comes with a convenient **carrying handle** for the fuselage and the struts. It is also useful during the remainder of the construction process because, when installed, it will allow you to turn the plane upside-down on the workbench without flexing or bending the center cabanes.

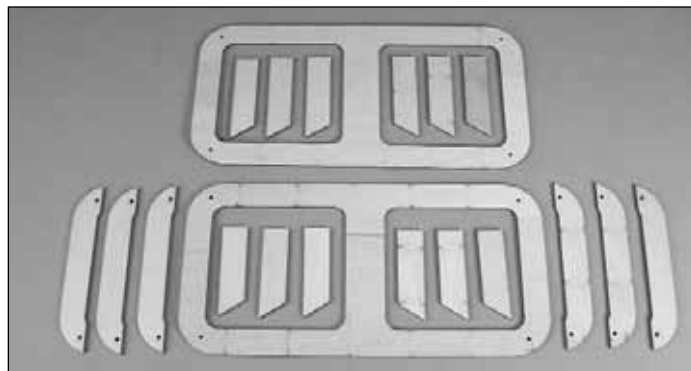

❑ 1. Locate all of the 1/8" [3mm] plywood parts of the carrying handle.

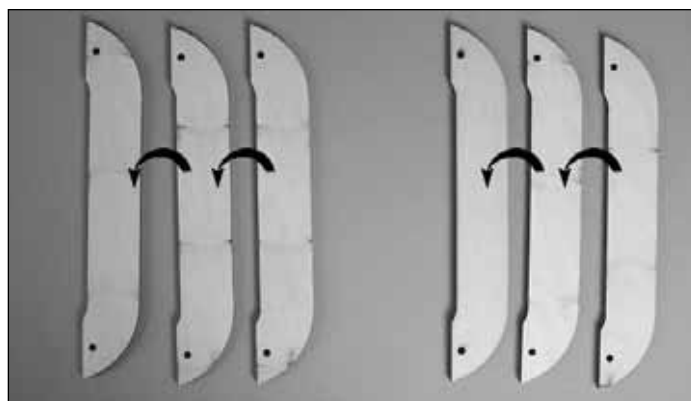

❑ 2. Glue the three parts of each set together as shown to make a pair 3/8" [9.5mm] thick.

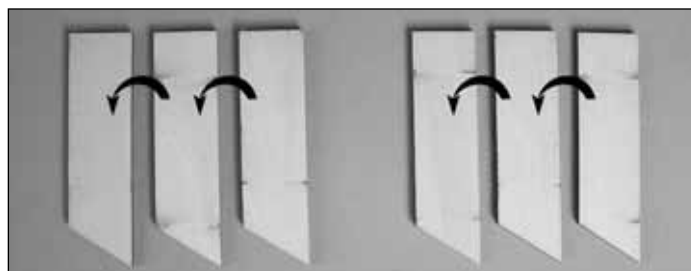

❑ 3. Do the same with the remaining six parts, making two pairs of each.

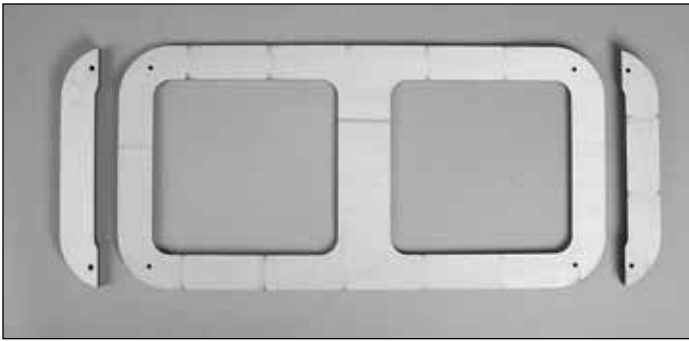

4. Glue the two parts shown onto one of the plywood carrying handle parts.

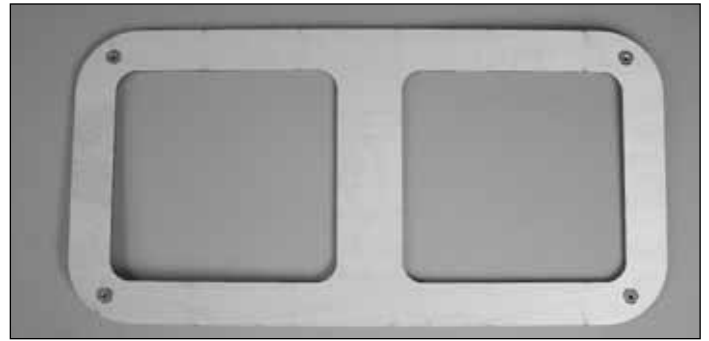

7. On the remaining handle part, install a 4-40 blind nut into each of the corner holes.

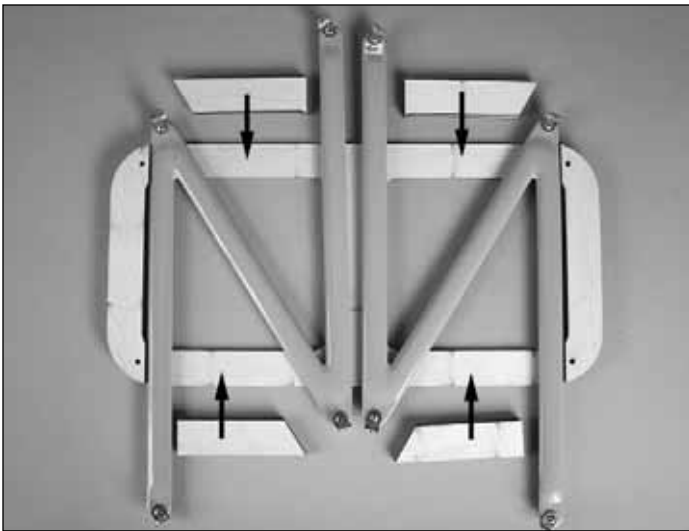

5. Place the "N" struts into the handle, leaving space between the struts in the center of the handle as shown. The remaining parts you glued together should fit between the "N" struts. Once you are sure the struts and the remaining pieces fit properly, glue the plywood parts to the handle.



8. Place the two "N" struts into the handle. Put the handle top onto the part of the handle holding the struts and place the completed handle on top of the cabanes. Secure the handle to the cabanes with four 4-40 x 3/4" [19mm] socket head cap screws and #4 flat washers. This is how the completed handle looks when you are storing the parts or taking the plane to the field.



6. Glue the 1/4" x 3/8" x 7" [6.4 x 9.5 x 178mm] balsa stick to the handle, between the struts.



9. For the following building steps it will be better to remove everything from the handle. Do this now and secure the empty handle to the cabanes.

Install the Engine & Throttle Servo

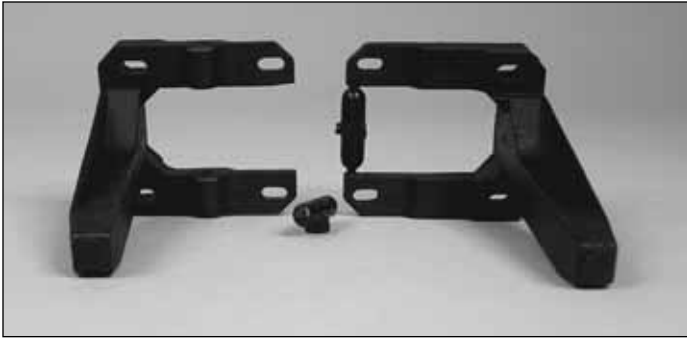

1. Cut the tabs from the **engine mount**. Install the engine mount (inverted) to the **firewall** with four 8-32 x 1-1/4" [32mm] socket head cap screws, #8 flat washers and #8 lock washers.

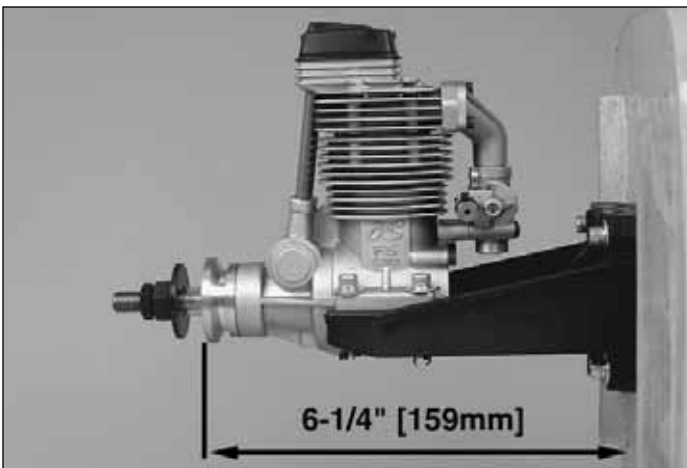

2. Position the engine on the mount so the distance from the firewall to the front of the thrust washer measures 6-1/4" [159mm]. Mark the location of the engine on the mount. The Great Planes Dead Center™ Hole Locator (GPMR8130) works well for this. Drill through the marks you have made on the engine mount with a #29 or 9/64" [3.6mm] drill bit. Tap each of the holes with an 8-32 tap.

3. Install the engine onto the mount with four each, 8-32 x 1" [25mm] socket head cap screws, #8 flat washers and #8 lock washers.



4. Drill a 3/16" [4.8mm] hole through the firewall in line with the **throttle arm** on the **carburetor**.

5. Locate the 24" [610mm] gray plastic **pushrod tube** and cut it 12-3/4" [324mm] in length. Sand one end of the tube with 220-grit sandpaper. Insert the tube into the firewall. Glue the roughened end of the tube flush to the firewall.



6. Place your **throttle servo** into the **servo tray** as shown. Drill a 1/16" [1.6mm] hole through each of the mounting holes. Remove the servo. Then install and remove a servo mounting screw into each hole. Apply a couple drops of thin CA into the holes to harden the threads. When the glue has cured permanently, mount the servo to the servo tray.



7. Cut the 1" [25mm] threaded end from the .074" x 17-1/2" [445mm] **throttle pushrod wire**. Install the wire into the tube and attach it to the servo horn arm with a FasLink. Use the same technique used for the ailerons.

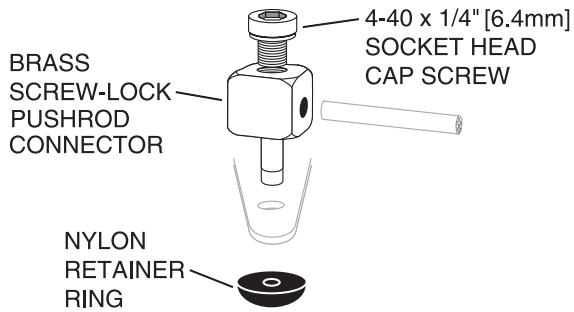

8. Attach the pushrod wire to the throttle arm with a **brass screw-lock pushrod connector**, **nylon retainer ring** and a **4-40 x 1/4" [6.4mm] socket head cap screw**.

Install the Cowl & Dummy Radial Engine



1. Glue four 1/4" x 1/4" x 1/4" [6.4 x 6.4 x 6.4mm] **hardwood blocks** to the firewall. Locate the blocks on the marks making certain that the side of the block is flush with the side of the fuselage.



2. Slide the fiberglass **cowl** onto the front of the fuselage. Cut the cowl as needed to allow the cowl to fit over the engine.

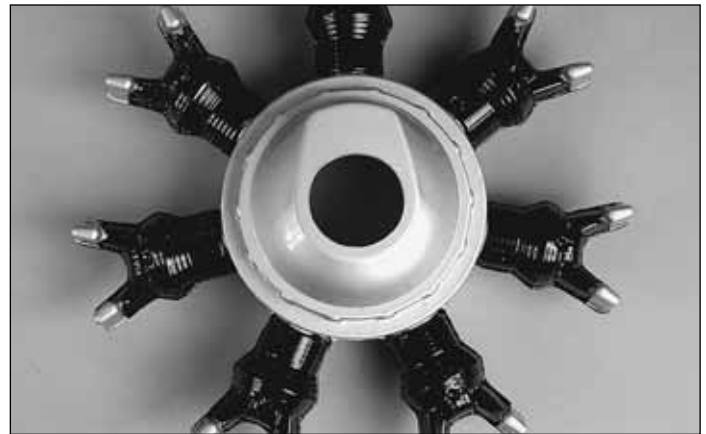
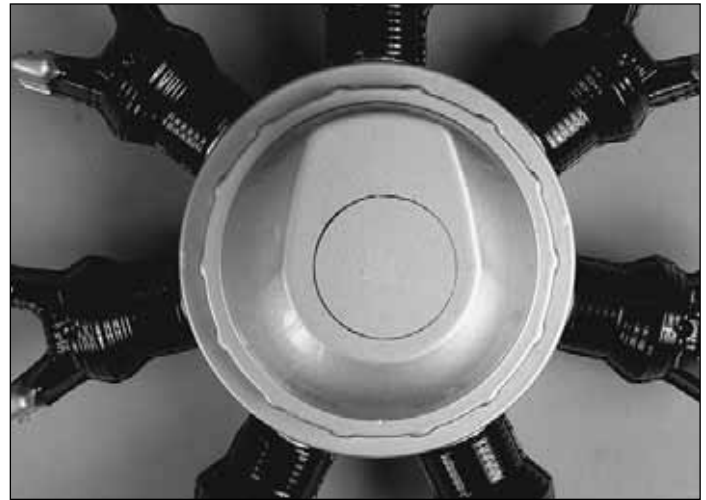

3. On the front of the **dummy radial engine** draw a circle approximately 1/16" [1.6mm] larger than the diameter of the thrust washer on the front of the engine. Be sure the hole is centered on the dummy radial engine. Cut out the circle.



4. Cut out the back of the dummy radial engine.

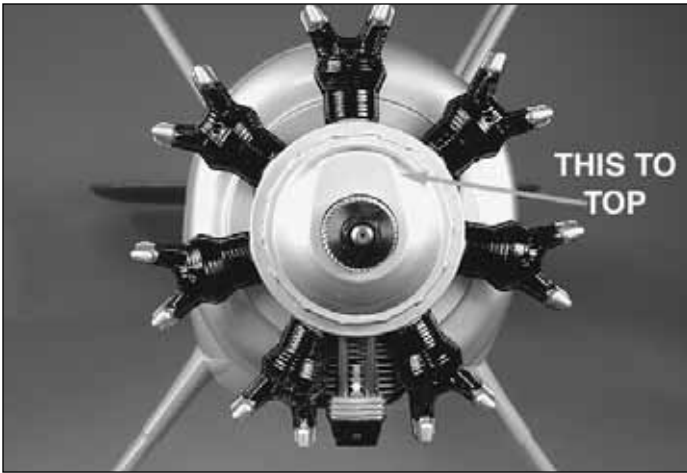

5. Slide the cowl over the engine followed by the dummy radial engine. **Note:** Position the dummy radial engine so that the top of the elongated shape of the front of the cowl is at the twelve o'clock position. Cut the dummy radial engine as needed until the engine fits into the cowl and the thrust washer on the engine extends through the front of the dummy radial engine. Cut small amounts of the dummy radial engine at a time. When complete there will only be a small amount of the back of the dummy radial engine that needs to be cut away.

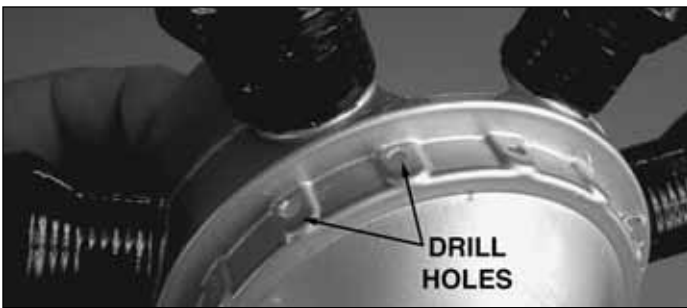

6. Drill two 1/8" [3mm] holes into the base of the **cylinder** and a hole into each **rocker cover**.

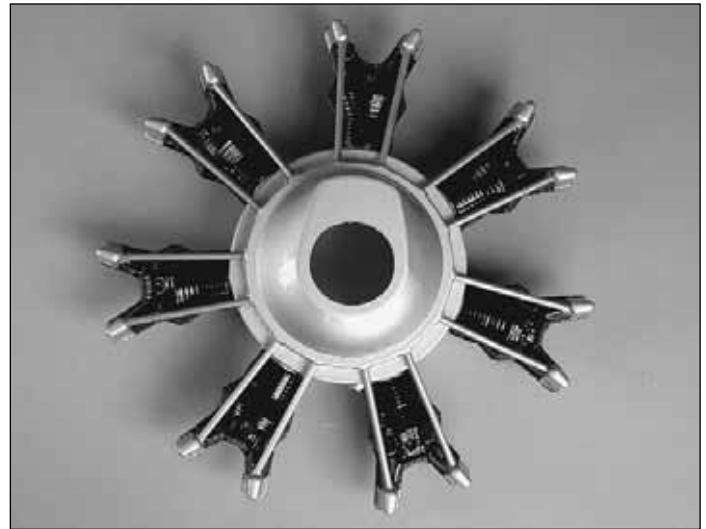

7. Insert an aluminum tube into each of the holes.

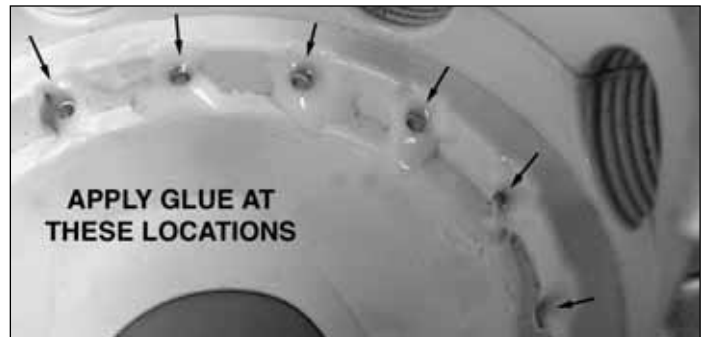

8. Turn the dummy radial engine over. Check to be sure that the tubes extend into the inside of the dummy radial engine. Glue the tubes to the dummy radial engine with a mixture of microballon filler and 6-minute epoxy.



□ 9. Drill a 1/16" [1.6mm] hole in the center of the **cylinder head** and at the base of the cylinder. Cut the included red wire into seven 1-3/4" [44mm] lengths. Insert the wire into the holes of each cylinder. Glue them in place with a small amount of CA glue.

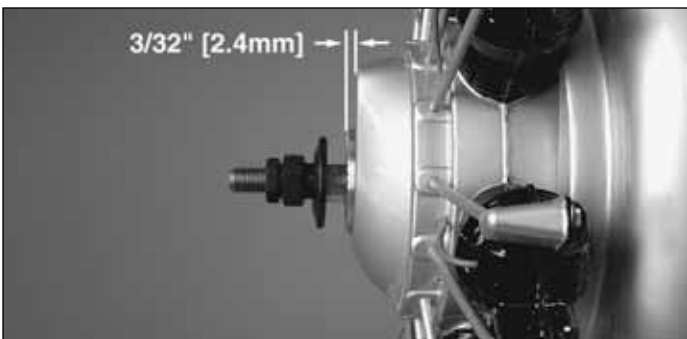

□ 10. Slide the cowl and the dummy radial engine onto the front of the fuselage. Position the cowl so that the front of the thrust washer of the engine extends beyond the front of the dummy radial engine 3/32" [2.4mm]. Once you are satisfied with the position of the dummy radial engine, apply a couple of drops of thin CA to the joint between the dummy radial engine and the cowl to tack glue the parts together. **Note:** There is no need to put excessive amounts of CA onto the joint. We will more securely glue the two parts together in the next step.

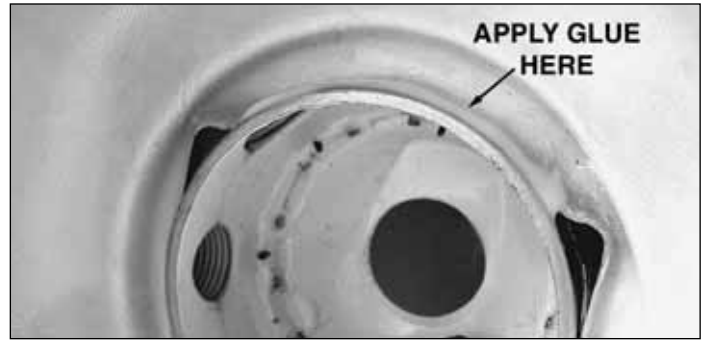

□ 11. Apply a mixture of microballoons and 6-minute epoxy to the inside of the cowl and dummy radial engine. This will securely attach the two parts.

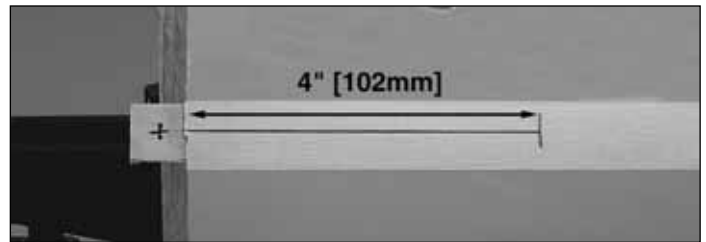

□ 12. Apply a piece of masking tape to the fuselage in line with the **cowl mounting blocks**. From the center of the mounting block draw a line back 4" [102mm] from the center of the block. Do this for all four cowl mounting blocks.



□ 13. Install the cowl to the fuselage, making sure that you center the engine in the hole in the front of the dummy radial engine and maintain the 3/32" [2.4mm] clearance for the engine thrust washer. When satisfied with the position of the cowl, measure forward from the end of the line 4" [102mm]. Make a mark on the cowl, then drill a 3/32" [2.4mm] hole through the cowl and into the cowl mounting block. Screw a #4 x 1/2" [13mm] sheet metal screw and #4 flat washer into the cowl and mounting block. Do this for all four of the cowl mounting blocks. Remove each of the screws and the cowl. Apply a couple of drops into the holes in the cowl mounting blocks to harden the threads.



- 14. Make any additional needed cut outs in the cowl for the **muffler**, **glow driver**, **needle valve**, etc.

Install the Fuel Tank

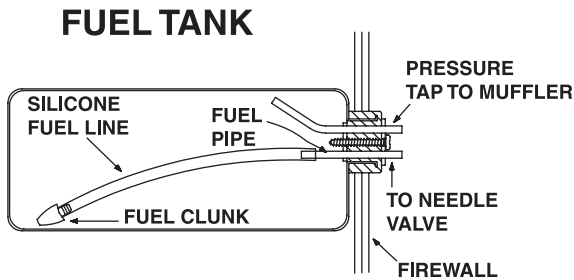

- 1. Assemble the **fuel tank** as shown in the sketch. When tightening the center screw be sure not to overtighten it. You just want it snug enough to pull the rubber stopper tight against the tank.
- 2. Install the tank into the fuselage with the neck of the tank through the firewall. The tank should fit snug enough to stay in place during the construction process. The tank will be permanently held in place when the **battery/receiver tray** is installed later.
- 3. Install silicone **fuel tubing** onto the aluminum tubes from the fuel tank. The line with the **fuel clunk** will feed to the **fuel inlet** at the needle valve and the other will attach to the **pressure tap** on the muffler. If you choose to use some kind of an external fuel valve, follow the instructions with your particular brand of fuel valve. You can also install a third line to the tank and use it for filling the tank. The method you use is your choice.

Assemble the Nose Weight Box

Our prototype model required the addition of nose weight with engines at the bottom end of the recommended range. This is not uncommon for short-coupled airplanes such as the PT-17 Military Stearman ARF. We have included a

location for you to easily add the weight that most likely will be needed.

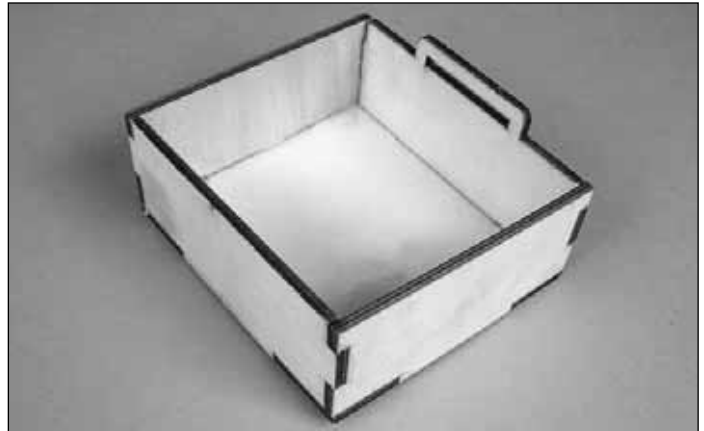
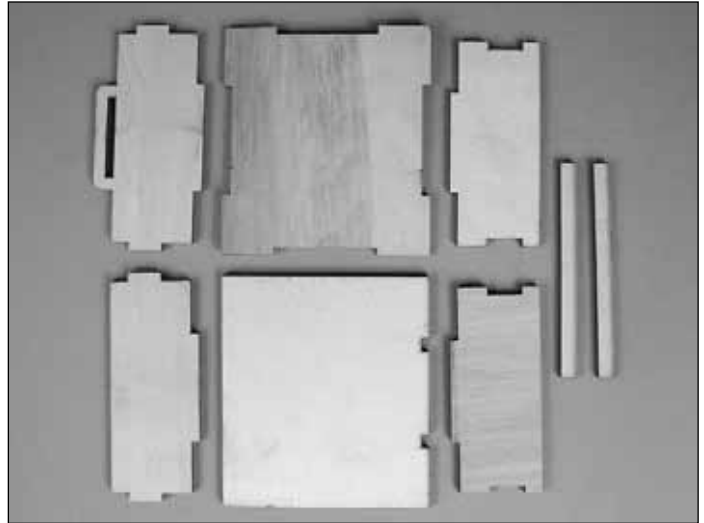

- 1. Locate the plywood parts that make up the **nose weight box**. Glue the box together as shown. The box will be exposed to engine vibration so be sure you have good glue joints.



- 2. Glue the two 1/8" x 1/4" x 3-1/4" [3 x 6.4 x 83mm] plywood **sticks** together. Then glue them to the front of the box.

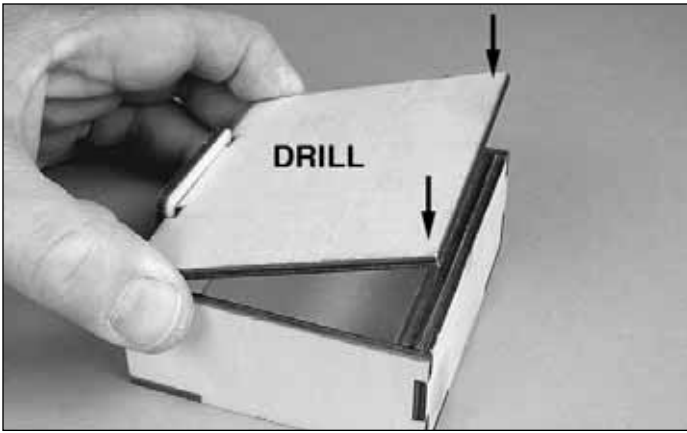

❑ 3. Fit the box cover to the box. Drill a 1/16" [1.6mm] hole at the locations shown. Install and then remove a #2 x 3/8" [9.5mm] sheet metal screw into each hole. Remove the cover, and then apply a couple of drops of thin CA into the holes in the box to harden the threads.

❑ 4. Referring to the photo on the following page, locate two 1/2" x 11/16" x 2-1/2" [13 x 18 x 64mm] hardwood **blocks**. Position one of the blocks on the bottom of the engine mount. The block should be resting against the engine mount rail and the socket head cap screw that holds the engine mount to the firewall. You will see that the block cannot sit on the rail because one of the engine mount bolts is extending through the rail. Mark the location of this screw on the block. Where you have marked the block, cut away enough of the wood to provide clearance for the screw, allowing the block to rest against the rail. Repeat this for the remaining block.

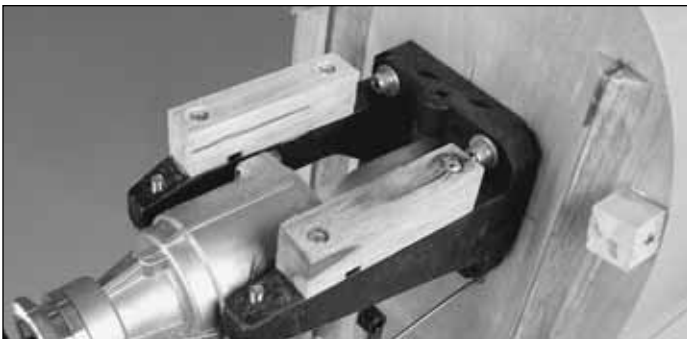

❑ 5. Glue the blocks to the engine mount rails with CA. Drill two 3/32" [2.4mm] holes through each of the blocks and the engine mount. **Drill a 1/8" [3mm] clearance hole through the block only! Do not drill into the engine mount with the 1/8" [3mm] bit!** Countersink the top of each of the holes you have drilled so that the screw heads will sit flush with the top of the hardwood blocks. Install a #4 x 1" [25mm] screw into each of the four holes, making sure that the head of the screw is flush or slightly below the top of the wood block.

❑ 6. Place the box on top of the rails and between the triangle stock located on the firewall. Drill four 1/16" [1.6mm] holes through the inside of the box and into the hardwood rails. Install and then remove a #2 x 3/8" [9.5mm] wood screw into each of the holes. Remove the box. Apply a couple of drops of thin CA into each of the holes to harden the threads. Allow the glue to cure.

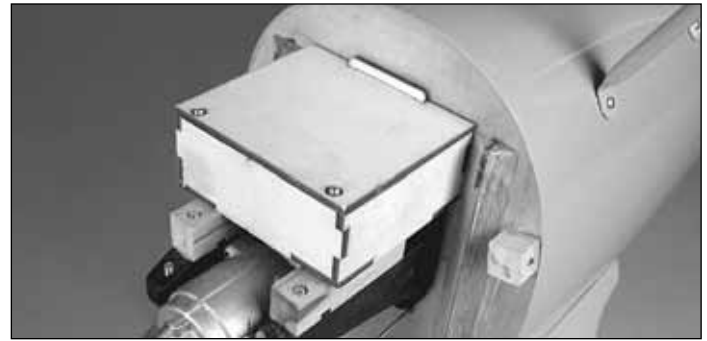

❑ 7. Attach the box to the hardwood blocks. Secure the top of the box with two #2 x 3/8" [9.5mm] screws and a two #2 washers. Fuelproof the box and rails.

That's it for now for our box for lead. When you get the plane ready for flight you will install the appropriate amount of ballast to balance the plane. **Hint:** You may wish to consider using the receiver battery for additional weight instead of mounting the battery in the fuselage.

***Did you know?...**Over the years the PT-17 Military Stearman has seen duty as a primary trainer, a reconnaissance plane, a crop duster, and an air show performer. In 1934 Argentina, Brazil and the Philippines used Stearmans featuring wing-mounted .30 caliber machine guns, a bomb rack between the landing struts and a single machine gun for the rear!*

Install the Wheels

❑ 1. Install the tailwheel onto the tailwheel wire, securing it with a 3/32" [2.4mm] wheel collar and a 4-40 set screw.

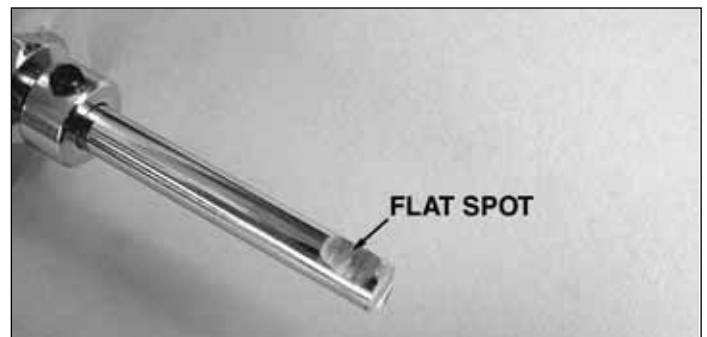

❑ ❑ 2. Cut the 2" [51mm] axles to a length of 1-1/2" [38mm]. Install the axle and axle nut onto both sides of the landing gear. File a flat spot at the end of the axle as shown.



□ □ 3. Look closely at the **wheels**. You will find that one side of the wheel has four screw holes drilled in the rim. The other side does not. Using silicone or 6-minute epoxy, glue one of the flat **wheel covers** onto the side of the wheel that does not have the holes in the rim.



□ □ 4. Screw a 6-32 set screw into a 3/16" [4.8mm] wheel collar. Slide the wheel collar onto the axle, positioning it as shown. Tighten the set screw against the axle.



□ □ 5. Slide the wheel onto the axle with the flat wheel cover to the inside. Screw a 6-32 x 1/4" [6.4mm] socket head cap screw into a 3/16" [4.8mm] wheel collar. Slide the wheel collar onto the axle and then tighten the screw against the flat spot on the axle.



□ □ 6. Attach the **cup-shaped outer wheel cover** to the wheel with four #2 x 3/8" [9.5mm] screws. The holes in the wheel cover align with the holes that are pre-drilled in the wheel. **Note:** Tighten the screws snugly to the wheel cover. Do not try to tighten the screws and the cover to the wheel.

□ 7. Repeat steps 2-6 for the left wheel.

Install the Radio System

□ 1. Cut the covering from the **pushrod tube openings** at the rear of the fuselage. There are two located on the right side and one located on the left. If you have trouble finding the openings, slide a .074" x 36" [914mm] pushrod wire into the tubes from inside of the fuselage, sliding it into the tube until it pushes the covering away from the fuselage slightly. This is where you should cut the covering away from the tubes.

□ 2. Locate three .074" x 36" [914mm] pushrod wires threaded on one end. Thread a nylon clevis onto the threaded end of each wire 20 full turns. Install a silicone clevis retainer onto the clevis.

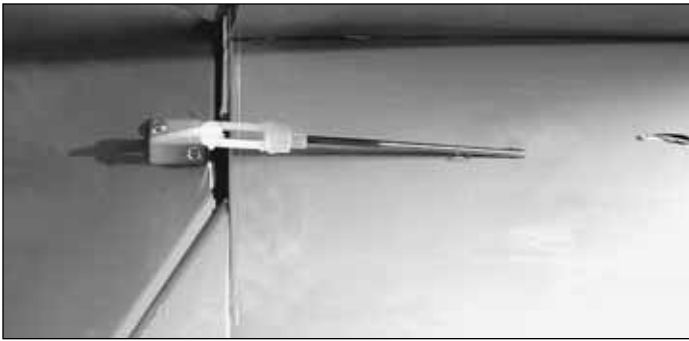

3. On the right side of the fuselage, slide one wire into the opening closest to the back of the fuselage. Install a nylon control horn onto the clevis. Position the control horn on the rudder, positioning it the same way you did with the ailerons. Mark the location for the screw holes. Drill through the marks you made with a 1/16" [1.6mm] drill bit, drilling only into the plywood plate. **Do not drill through the rudder!** Install and then remove two 2-56 x 5/8" [16mm] machine screws. Apply a couple drops of thin CA into the holes. Once the glue has cured, mount the horn and the nylon mounting plate to the rudder with the screws.



4. Install the two **elevator pushrods** using the same procedure used for the rudder. Be sure when installing the control horn on the **right elevator** that you install it so it does not conflict with the **rudder control horn**.



5. Place your **rudder servo** into the servo tray as shown, positioning the last hole of the servo arm over the pushrod wire. Drill a 1/16" [1.6mm] hole through each of the mounting holes. Remove the servo, then install and remove a servo mounting screw into each hole. Apply a couple drops of thin CA into the holes to harden the threads. When the glue has cured, permanently mount the servo to the servo tray.

6. Center the rudder and the rudder servo, then install the servo arm. At the point the pushrod wire intersects the

last hole in the servo arm make a mark. Bend the wire 90 degrees on that mark. Install a nylon FasLink and cut off the excess wire the same as was done with the throttle servo.

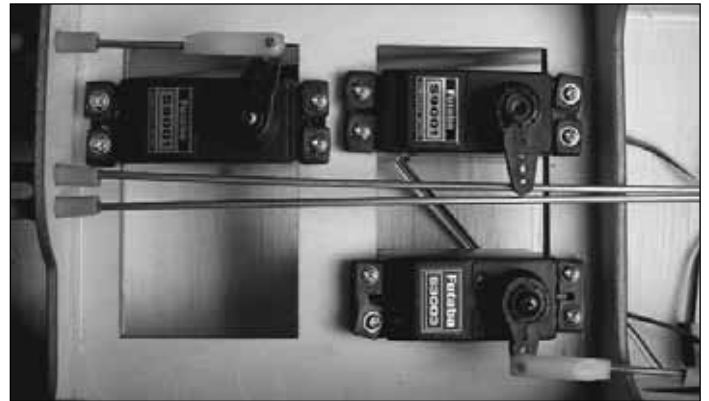

7. Place your **elevator servo** into the servo tray as shown, positioning the last hole of the servo arm over the inside pushrod wire. Drill a 1/16" [1.6mm] hole through each of the mounting holes. Remove the servo, then install and remove a servo mounting screw into each hole. Apply a couple drops of thin CA into the holes to harden the threads. When the glue has cured permanently, mount the servo to the servo tray.

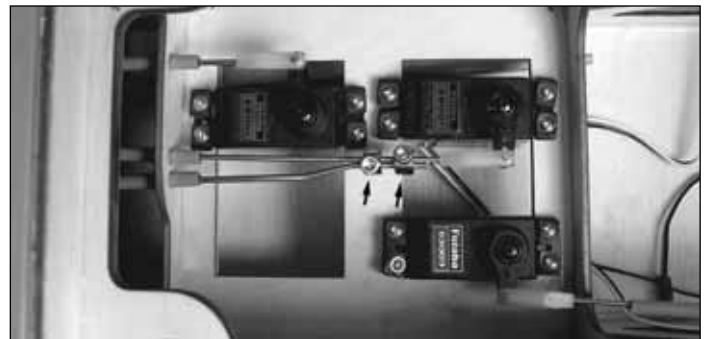

8. Bend the **outer elevator pushrod** as shown. Cut off the excess wire. Center both of the elevators, then center the elevator servo. Secure the two pushrod wires with two 5/32" [4mm] wheel collars and 6-32 x 1/4" [6.4mm] socket head cap screw. Attach the elevator pushrod to the servo arm with a nylon FasLink using the same technique used on the rudder and throttle.

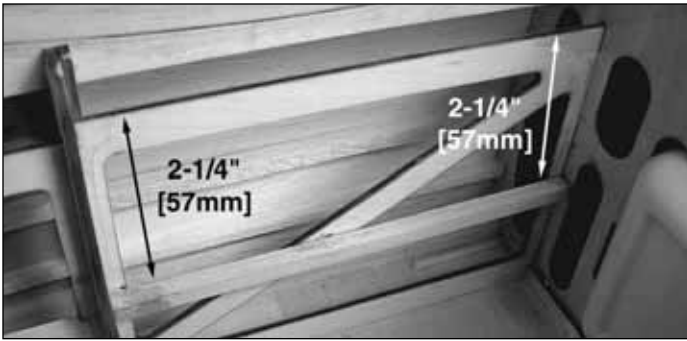

9. Measure down 2-1/4" [57mm] from the top of the **fuselage former** and make a line on the former. Do this on both sides of the fuselage. Locate two 1/4" x 1/4" x 6" [6.4 x 6.4 x 152mm] hardwood **sticks**. Securely glue them to the former, aligning the top of the stick with the lines you marked on the formers.

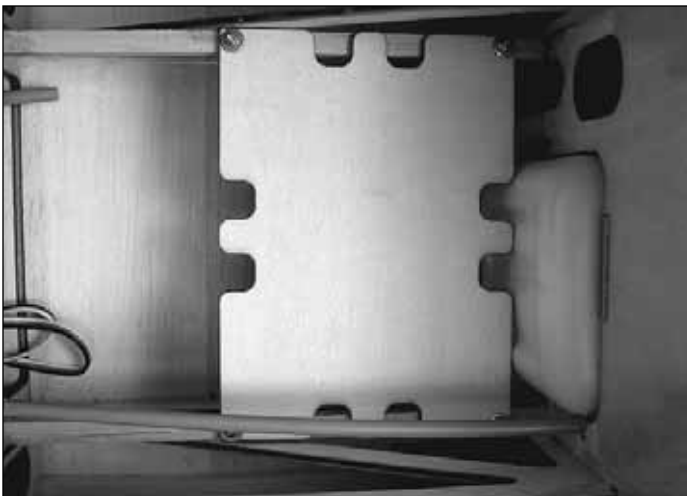

10. Locate the 1/8" [3mm] plywood receiver/battery tray. Place it on top of the hardwood sticks you glued in and place the tray against the fuel tank to keep the fuel tank in position. Drill a 1/16" [1.6mm] hole through the mounting holes in the tray and into the hardwood sticks. Insert and then remove a #2 x 3/8" [9.5mm] screw into each of the holes. Then apply a couple of drops of thin CA into the holes to harden the threads. Once the glue has cured the tray can

be mounted with four #2 x 3/8" [9.5mm] sheet metal screws and #2 washers. Do not install the tray at this time.

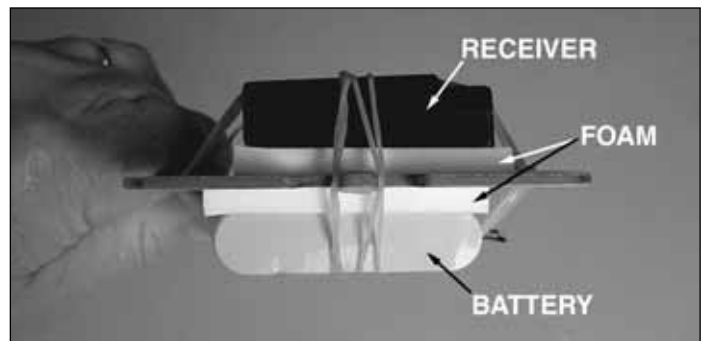
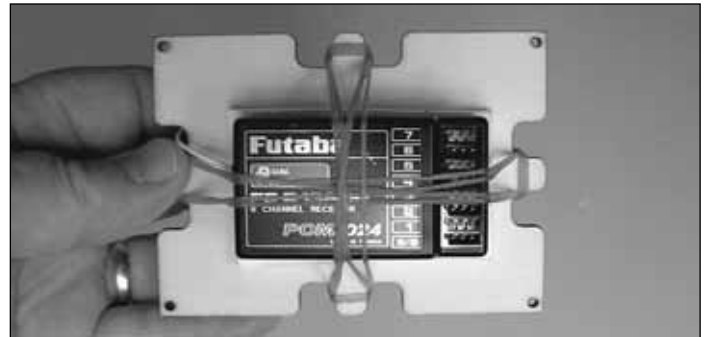

11. On one side of the tray, place 1/4" [6.4mm] **foam** between the receiver and the tray. On the other side place 1/4" [6.4mm] foam between the tray and the **battery pack**. Use #64 rubber bands to hold the receiver and battery to the tray.

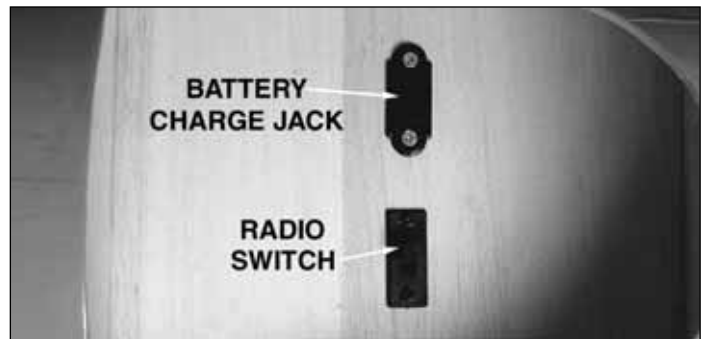

12. We installed the **radio switch** and the **battery charge jack** inside the front **cockpit**. Place a pilot in the cockpit as your guide for positioning the switch and charge jack.

13. Connect the battery to the radio switch and secure the ends of the leads with heat-shrink tubing, tape or some other method for securing the leads.

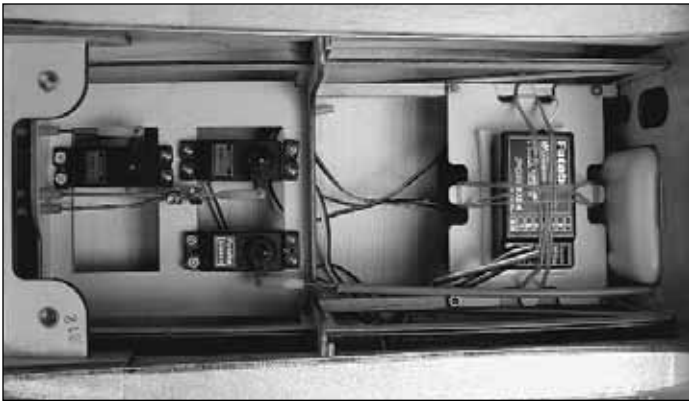

□ 14. Install the tray as shown and secure it to the rails with the #2 x 3/8" [9.5mm] sheet metal screws and #2 washers. Plug your servos and battery into the receiver. Route the **receiver antenna** into the **antenna tube** located under the servo tray. Slide the antenna completely into the tube. The fuselage and antenna tube are long enough that the antenna will not exit the fuselage.

Finishing Touches

□ 1. Paint the **cockpits** flat black.

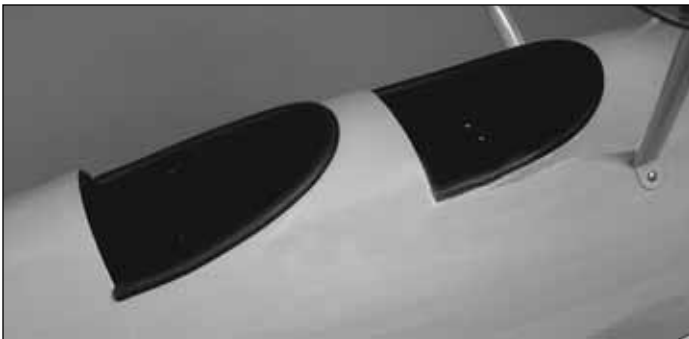

□ 2. Locate two pieces of black **cockpit coaming**. Look closely and you will see that there is a slit in it. Slide the coaming onto the edge of the cockpits. Glue it in place with R/C 56 canopy glue. This glue sticks well to MonoKote, eliminating the need to cut any covering in order to expose wood for a good bond.



□ 3. Cut the **windcreens** on the cut lines. Glue them in place with R/C 56 canopy glue.



□ 4. Your kit includes two **pilots**. Make a bottom for the pilots from balsa or other scrap you may have. Glue the pilot base to the pilots. Glue one pilot in each cockpit with 6-minute epoxy.

Optional Flying Wire Installation

The photos on the box show optional flying wires installed on the plane. The materials we used for this are not included in the kit but are readily available at any fabric store for less than \$10.00. The wires are made from an elastic cord typically used for sewing an elastic cuff in a sleeve. The material is commonly called, "Beading Cord Elastic."



You will need approximately seven yards, two small packages. The method described here will provide a

reasonably scale appearance without the hassles typically associated with flying wires. Because they are made from elastic there is no need to tension them each time you put the plane together. These wires will add approximately two minutes to the overall assembly time of the plane at the flying field.

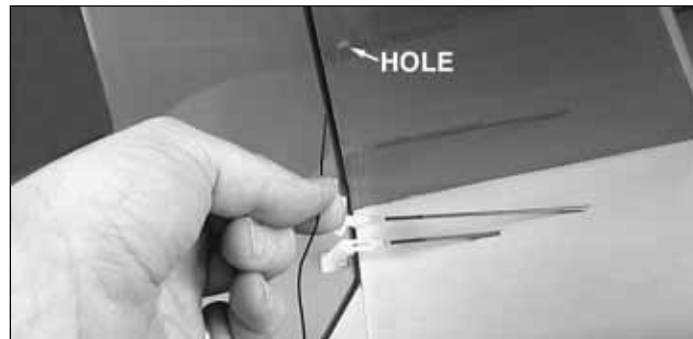

4. Cut a piece of the elastic cord 50" [1270mm] long. This length should be relaxed, not stretched. In order to feed the elastic cord through the holes you have drilled, apply a few drops of thin CA to one end of the elastic cord, covering approximately 1" [25mm] of the cord. On the opposite end of the cord put a small drop of CA, just enough to make the end of the cord hard. On this end of the cord, apply a small drop of CA to the end and insert it into the hole in the block. Hold the cord in place until the glue cures. Thread the opposite end of the cord through the hole in the leading edge of the stab as shown.

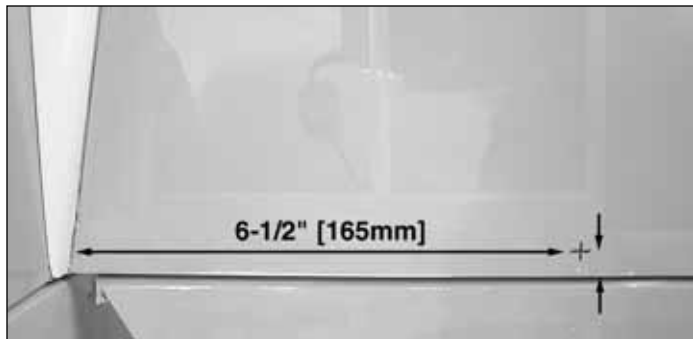

1. Measure from the fillet at the trailing edge of the stab out toward the tip of the stab 6-1/2" [165mm] and make a mark with a felt-tip pen. Measure in from the trailing edge of the stab 1/4" [6.4mm] and make a crossing mark. Do the same on the leading edge of the stab. Do this on both sides of the stab.



5. Thread the cord through the hole in the leading edge of the fin.

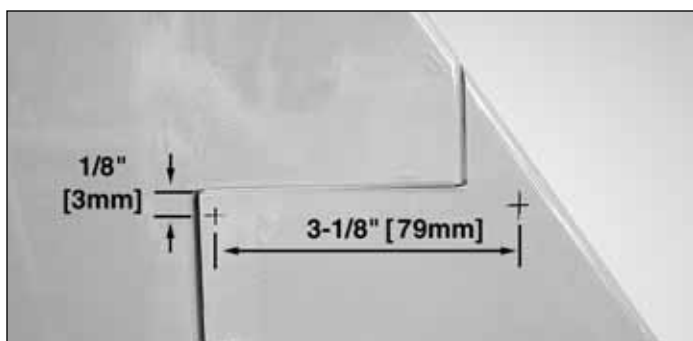

2. At the rear corner of the fin, measure down and in 1/8" [3mm]. From the intersection of those lines make a mark on the front of the fin 3-1/8" [79mm]. On the marks, drill a hole through the fin with a 5/64" [2mm] drill.



3. Drill a 5/64" [2mm] hole through the block at the back of the fuselage.



6. Continue threading the cord through the hole in the leading edge of the stab on the opposite side of the fuselage.

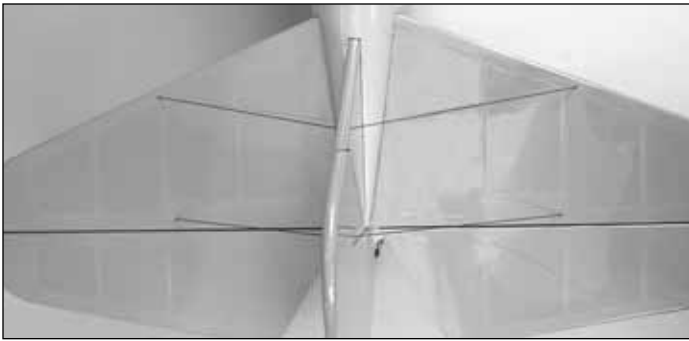

7. At this point you will have to start stretching the elastic to complete the positioning of the elastic cord. Pull the cord around the tailwheel wire, then thread the cord through the trailing edge of the stab and fin back to the hole you drilled through in the block at the back of the fuselage.



8. Make two marks $1/2$ " [13mm] apart $1/4$ " [6.4mm] above the landing gear. Drill partially into the fuselage on each of the four marks $5/64$ " [2mm].



9. Put a small drop of CA on the cord, then insert it into the hole shown.

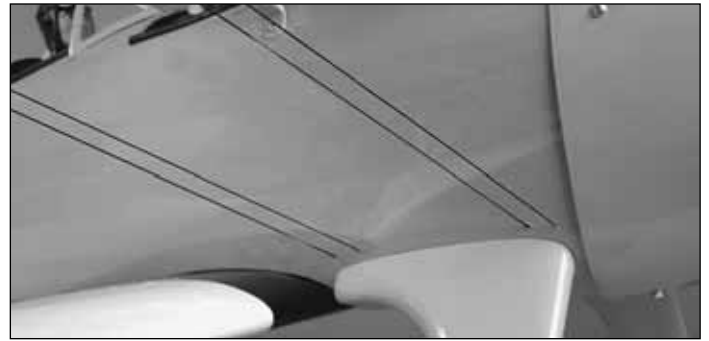

10. Bring the elastic cord around the top of the forward strut and pull it back toward the fuselage. Glue the cord into the hole next to the hole you started with.



11. On the end of a piece of elastic cord at least 40" [1016mm] long make a loop using CA glue to glue the cord together. This loop must be large enough for a 4-40 bolt to go through.



12. Install the 4-40 bolt through the loop and tighten the bolt against the cabane.



13. Pull the cord down around the bottom of the forward strut and back up to the front cabane. Make a loop on the end of the cord and attach it to the front cabane bolt.



14. This completes the wires for the right side. Repeat steps 1-13 for the opposite side.

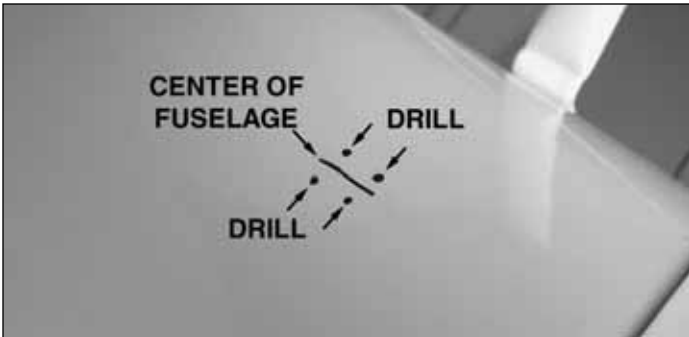

15. Make a mark identifying the top center of the fuselage. Mark four holes as shown. Drill partially into the fuselage with a 5/64" [2mm] drill on each of the four marks.



16. Cut four pieces of elastic cord 4-1/4" [108mm] long. Glue a cord into each of the four holes. Stretch the cord to the top of the cabane and glue the cord to the cabane with a small drop of CA.

Apply the Decals

The Stearman was primarily a fabric-covered aircraft, but there were some panel lines along the top of the fuselage. In addition to the photographs on the box, the following pictures should help you in the placement of the decals.



1. Use scissors or a sharp hobby knife to cut the decals from the sheet.

2. Be certain the model is clean and free from oily fingerprints and dust. Prepare a dishpan or small bucket with a mixture of liquid dish soap and warm water-about one teaspoon of soap per gallon of water. Submerge the decal in the soap and water and peel off the paper backing.

Note: Even though the decals have a "sticky-back" and are not the water transfer type, submersing them in soap & water allows accurate positioning and reduces air bubbles underneath.

3. Position decals on the model as shown on the box cover. Holding the decal down, use a paper towel to wipe most of the water away.

- 4. Use a piece of soft balsa or something similar to squeegee remaining water from under the decal. Apply the rest of the decals the same way.

GET THE MODEL READY TO FLY

Check the Control Directions

- 1. Turn on the transmitter and receiver and center the trims. If necessary, remove the servo arms from the servos and reposition them so they are centered. Reinstall the screws that hold on the servo arms.
- 2. With the transmitter and receiver still on, check all the control surfaces to see if they are centered. If necessary, adjust the clevises on the pushrods to center the control surfaces.

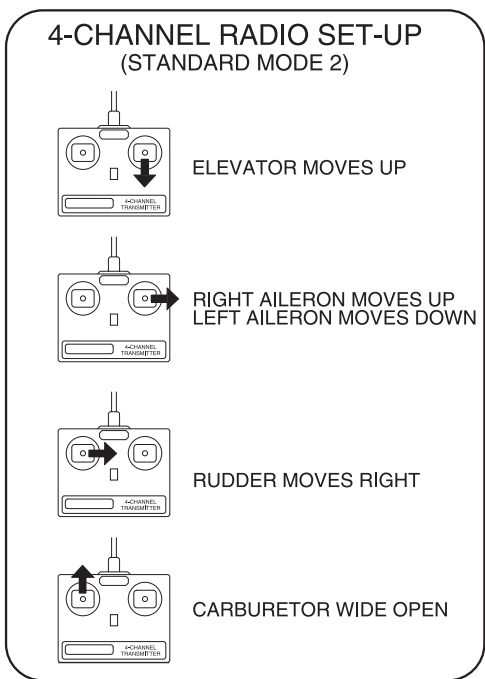

- 3. Make certain that the control surfaces and the carburetor respond in the correct direction as shown in the diagram. If any of the controls respond in the wrong direction, use the servo reversing in the transmitter to reverse the servos connected to those controls. Be certain the control surfaces have remained centered. Adjust if necessary.

Set the Control Throws



Use a Great Planes AccuThrow (or a ruler) to accurately measure and set the control throw of each control surface as indicated in the chart that follows. If your radio does not have dual rates, we recommend setting the throws at the low rate setting.

Note: The throws are measured at the **widest part** of the elevators, rudder and ailerons.

These are the recommended control surface throws:		
	High Rate	Low Rate
ELEVATOR:	1" [25mm] up 1" [25mm] down	7/8" [22mm] up 7/8" [22mm] down
AILERONS:	1-1/2" [38mm] up 1-1/2" [38mm] down	1" [25mm] up 1" [25mm] down
RUDDER:	1-1/2" [38mm] up 1-1/2" [38mm] down	1" [25mm] up 1" [25mm] down

IMPORTANT: The PT-17 Military Stearman ARF has been **extensively** flown and tested to arrive at the throws at which it flies best. Flying your model at these throws will provide you with the greatest chance for successful first flights. If, after you have become accustomed to the way the PT-17 Military Stearman ARF flies, you would like to change the throws to suit your taste, that is fine. However, too much control throw could make the model difficult to control, so remember, "more is not always better."

Balance the Model (C.G.)

More than any other factor, the **C.G.** (balance point) can have the **greatest** effect on how a model flies, and may determine whether or not your first flight will be successful. If you value this model and wish to enjoy it for many flights, **DO NOT OVERLOOK THIS IMPORTANT PROCEDURE.** A model that is not properly balanced will be unstable and possibly unflyable.

At this stage the model should be in ready-to-fly condition with all of the systems in place including the engine, landing gear, covering, and the radio system. The PT-17 Military Stearman ARF is a short-coupled airplane, making it nearly impossible to balance without the addition of some nose weight. Earlier you installed a box to hold lead. Remove the spinner and cowl. Remove the cover from the box and install lead. Great Planes (GPMQ4485) "stick-on" lead works well. All of our prototypes had an O.S.[®] .91 four-stroke engine and required approximately 18 oz. of lead. This should be a good starting point for balancing your plane too. After putting the lead in the box be sure to re-install the cowl, spinner and propeller. After you install nose weight, pack the inside of the box tight with foam rubber to prevent any lead from coming loose and rattling around inside the box.

This is where your model should balance for the first flights. Later, you may wish to experiment by shifting the C.G. up to 1/8" [3mm] forward or 1/8" [3mm] back to change the flying characteristics. Moving the C.G. forward may improve the smoothness and stability, but the model may then require more speed for takeoff and make it more difficult to slow for landing. Moving the C.G. aft makes the model more maneuverable, but could also cause it to become too difficult to control. In any case, **start at the recommended balance point** and do not at any time balance the model outside the specified range.

1. Use a felt-tip pen or 1/8" [3mm] wide tape to accurately mark the C.G. on the bottom of the top wing (on both sides of the fuselage.) The C.G. is located 5-1/2" [140mm] back from the leading edge of the top wing.
2. With the wing attached to the fuselage, all parts of the model installed (ready to fly) and an empty fuel tank, lift it at the balance point you marked.
3. If the tail drops, the model is "tail heavy" and the battery pack and/or receiver must be shifted forward or weight must be added to the nose to balance. If the nose drops, the model is "nose heavy" and the battery pack and/or receiver must be shifted aft or weight must be added to the tail (or removed from the weight box) to balance.
4. **IMPORTANT:** If you found it necessary to add any weight, recheck the C.G. after the weight has been installed.

Balance the Model Laterally

1. With the wings level, have an assistant help you lift the model by the engine propeller shaft and the bottom of the fuse under the TE of the fin. Do this several times.
2. If one wing always drops when you lift the model, it means that side is heavy. Balance the airplane by adding weight to the other wing tip. **An airplane that has been laterally balanced will track better in loops and other maneuvers.**

PREFLIGHT

Identify Your Model

No matter if you fly at an AMA sanctioned R/C club site or if you fly somewhere on your own, you should always have your name, address, telephone number and AMA number on or inside your model. It is required at all AMA R/C club flying sites and AMA sanctioned flying events. Fill out the identification tag on the decal sheet and place it on or inside your model.

Change the Batteries

Follow the battery charging instructions that came with your radio control system to charge the batteries. You should always charge your transmitter and receiver batteries the night before you go flying, and at other times as recommended by the radio manufacturer.

Note: Checking the condition of your receiver battery pack is **highly recommended.** All battery packs, whether it's a trusty pack you've just taken out of another model, or a new battery pack you just purchased, should be cycled, noting the discharge capacity. Oftentimes, a weak battery pack can be identified (and a valuable model saved!) by comparing its actual capacity to its rated capacity. Refer to the instructions and recommendations that come with your cycler. If you don't own a battery cycler, perhaps you can have a friend cycle your pack and note the capacity for you.

Balance the Propellers

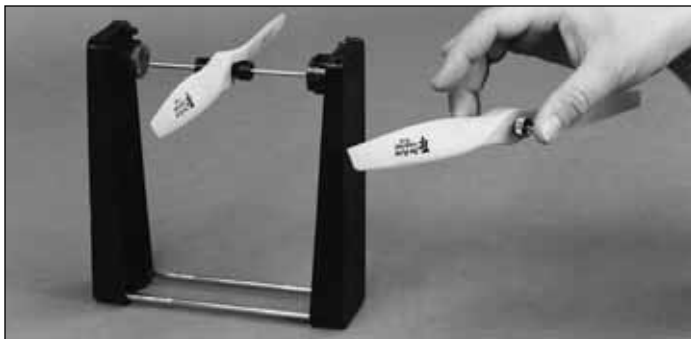

Carefully balance your propeller and spare propellers before you fly. An unbalanced prop can be the single most significant cause of vibration that can damage your model. Not only will engine mounting screws and bolts loosen, possibly with disastrous effect, but vibration may also damage your radio receiver and battery. Vibration can also cause your fuel to foam, which will, in turn, cause your engine to run hot or quit.

We use a Top Flite Precision Magnetic Prop Balancer™ (TOPQ5700) in the workshop and keep a Great Planes Fingertip Prop Balancer (GPMQ5000) in our flight box.

Ground Check

If the engine is new, follow the engine manufacturer's instructions to break-in the engine. After break-in, confirm that the engine idles reliably, transitions smoothly and rapidly to full power and maintains full power indefinitely. After you run the engine on the model, inspect the model closely to make sure all screws remained tight, the hinges are secure, the prop is secure and all pushrods and connectors are secure.

Range Check

Ground check the operational range of your radio before the first flight of the day. With the transmitter antenna collapsed and the receiver and transmitter on, you should be able to walk at least 100 feet away from the model and still have control. Have an assistant stand by your model and, while you work the controls, tell you what the control surfaces are doing. Repeat this test **with the engine running** at various speeds with an assistant holding the model, using hand signals to show you what is happening. If the control surfaces do not respond correctly, **do not fly!** Find and correct the problem first. Look for loose servo connections or broken wires, corroded wires on old servo connectors, poor solder joints in your battery pack or a defective cell, or a damaged receiver crystal from a previous crash.

ENGINE SAFETY PRECAUTIONS

Failure to follow these safety precautions may result in severe injury to yourself and others.

Keep all engine fuel in a safe place, away from high heat, sparks or flames, as fuel is very flammable. Do not smoke near the engine or fuel; and remember that engine exhaust gives off a great deal of deadly carbon monoxide. Therefore, **do not run the engine in a closed room or garage.**

Get help from an experienced pilot when learning to operate engines.

Use safety glasses when starting or running engines.

Do not run the engine in an area of loose gravel or sand; the propeller may throw such material in your face or eyes.

Keep your face and body as well as all spectators away from the plane of rotation of the propeller as you start and run the engine.

Keep these items away from the prop: loose clothing, shirt sleeves, ties, scarfs, long hair or loose objects such as pencils or screwdrivers that may fall out of shirt or jacket pockets into the prop.

Use a "chicken stick" or electric starter to start the engine. Do not use your fingers to flip the propeller. Make certain the glow plug clip or connector is secure so that it will not pop off or otherwise get into the running propeller.

Make all engine adjustments from behind the rotating propeller.

The engine gets hot! Do not touch it during or right after operation. Make sure fuel lines are in good condition so fuel will not leak onto a hot engine, causing a fire.

To stop a glow engine, cut off the fuel supply by closing off the fuel line or following the engine manufacturer's recommendations. Do not use hands, fingers or any other body part to try to stop the engine. To stop a gasoline powered engine an on/off switch should be connected to the engine coil. Do not throw anything into the propeller of a running engine.

AMA SAFETY CODE (excerpts)

Read and abide by the following excerpts from the Academy of Model Aeronautics Safety Code. For the complete Safety Code refer to *Model Aviation* magazine, the AMA web site or the Code that came with your AMA license.

GENERAL

1. I will not fly my model aircraft in sanctioned events, air shows, or model flying demonstrations until it has been proven to be airworthy by having been previously successfully flight tested.

2. I will not fly my model aircraft higher than approximately 400 feet within 3 miles of an airport without notifying the airport operator. I will give right of way to, and avoid flying in the proximity of full-scale aircraft. Where necessary an observer shall be used to supervise flying to avoid having models fly in the proximity of full-scale aircraft.

3. Where established, I will abide by the safety rules for the flying site I use, and I will not willfully and deliberately fly my models in a careless, reckless and/or dangerous manner.

7. I will not fly my model unless it is identified with my name and address or AMA number, on or in the model.

9. I will not operate models with pyrotechnics (any device that explodes, burns, or propels a projectile of any kind).

RADIO CONTROL

1. I will have completed a successful radio equipment ground check before the first flight of a new or repaired model.

2. I will not fly my model aircraft in the presence of spectators until I become a qualified flier, unless assisted by an experienced helper.

3. I will perform my initial turn after takeoff away from the pit or spectator areas, and I will not thereafter fly over pit or spectator areas, unless beyond my control.

4. I will operate my model using only radio control frequencies currently allowed by the Federal Communications Commission.

IMAA SAFETY CODE (excerpts)

Since the PT-17 Military Stearman ARF qualifies as a “giant-scale” model and is therefore eligible to fly in IMAA events, we’ve included excerpts from the IMAA Safety Code.

Definition: For the purpose of the following IMAA Safety Code, the term “Giant-Scale” shall refer to radio controlled model aircraft, either scale or non-scale, which have a wingspan of 80 inches or more for monoplanes and 60 inches or more for multi-winged model aircraft and have a ramp weight (fueled and ready to fly) of 55 lbs. or less.

Section 1.0: SAFETY STANDARD

1.1 Adherence to Code: This safety code is to be strictly followed

1.2 The most current AMA Safety Code in effect is to be observed. However, the competition sections of the code may be disregarded.

Section 3.0: SAFETY CHECK

3.4 Flight Testing: All Giant-Scale R/C aircraft are to have been flight-tested and flight trimmed with a minimum of six flights before the model is allowed to fly at an IMAA Sanctioned event.

3.5 Proof of Flight: The completing and signing of the Declaration section of the Safety Inspection form by the pilot (or owner) shall document as fact that each aircraft has been successfully flight-tested and proven airworthy prior to an IMAA event.

Section 5.0: EMERGENCY ENGINE SHUT OFF (kill switch)

5.1 All magneto spark ignition engines must have a coil grounding switch on the aircraft to stop the engine. This will also prevent accidental starting of the engine. This switch shall be readily available to both pilot and helper. This switch is to be operated manually and without the use of the radio system.

5.2 Engines with battery power ignition systems must have a switch to turn off the power from the battery pack to disable the engine from firing. This will also prevent accidental starting of the engine. This switch shall be readily available to both pilot and helper. This switch shall be operated manually and without the use of the Radio System.

5.3 There must also be a means to stop the engine from the transmitter. The most common method is to close the carburetor throat completely using throttle trim; however, other methods are acceptable. This requirement applies to all glow/gas ignition engines regardless of size.

Section 6.0: RADIO REQUIREMENTS

6.1 All transmitters must be FCC type certified.

6.2 FCC Technician or higher-class license required for 6 meter band operation only.

CHECK LIST

- 1. Fuelproof all areas exposed to fuel or exhaust residue such as the cowl mounting blocks, wing saddle area, etc.
- 2. Check the C.G. according to the measurements provided in the manual.
- 3. Be certain the battery and receiver are securely mounted in the fuse. Simply stuffing them into place with foam rubber is not sufficient.
- 4. Extend your receiver antenna and make sure it is in the antenna tube.
- 5. Balance your model *laterally*.
- 6. Use thread-locking compound to secure critical fasteners such as the set screws that hold the wheel axles to the struts, screws that hold the carburetor arm (if applicable), screw-lock pushrod connectors, etc.
- 7. Add a drop of oil to the wheel axles.
- 8. Make sure all hinges are **securely** glued in place.

- 9. Reinforce holes for wood screws with thin CA where appropriate (servo mounting screws, cowl mounting screws, etc.).
- 10. Confirm that all controls operate in the correct direction and the throws are set up according to the manual.
- 11. Make sure there are silicone retainers on all the clevises and that all servo arms are secured to the servos with the screws included with your radio.
- 12. Secure connections between servo wires and Y-connectors or servo extensions, and the connection between your battery pack and the on/off switch with vinyl tape, heat-shrink tubing or special clips suitable for that purpose.
- 13. Make sure any servo extension cords you may have used do not interfere with other systems (servo arms, pushrods, etc.).
- 14. Secure the pressure tap (if used) to the muffler with high temp RTV silicone, thread-locking compound or J.B. Weld.
- 15. Make sure the fuel lines are connected and not kinked.
- 16. Balance your propeller (and spare propellers).
- 17. Tighten the propeller nut and spinner.
- 18. Place your name, address, AMA number and telephone number on or inside your model.
- 19. Cycle your receiver battery pack (if necessary) and make sure it is fully charged.
- 20. If you wish to photograph your model, do so before your first flight.
- 21. Range check your radio when you get to the flying field.
- 22. Make sure all wing attachment bolts and screws are securely tightened.

FLYING

Fuel Mixture Adjustments

A fully cowled engine may run at a higher temperature than an un-cowled engine. For this reason, the fuel mixture should be richened so the engine runs at about 200 RPM below peak speed. By running the engine slightly rich, you will help prevent dead-stick landings caused by overheating.

CAUTION (THIS APPLIES TO ALL R/C AIRPLANES): If, while flying, you notice an alarming or unusual sound such as a low-pitched “buzz,” this may indicate control surface *flutter*. Flutter occurs when a control surface (such as an aileron or elevator) or a flying surface (such as a wing or stab) rapidly vibrates up and down (thus causing the noise). In extreme cases, if not detected immediately, flutter can actually cause the control surface to detach or the flying surface to fail, thus causing loss of control followed by an impending crash. The best thing to do when flutter is detected is to slow the model **immediately** by reducing power, then land as soon as safely possible. Identify which surface fluttered (so the problem may be resolved) by checking all the servo grommets for deterioration or signs of vibration. Make certain all pushrod linkages are secure and free of play. If it fluttered once, under similar circumstances it will probably flutter again unless the problem is fixed. Some things which can cause flutter are; Excessive hinge gap; Not mounting control horns solidly; Poor fit of clevis pin in horn; Side-play of wire pushrods caused by large bends; Excessive free play in servo gears; Insecure servo mounting; and one of the most prevalent causes of flutter; Flying an over-powered model at excessive speeds.

Take Off

Before you get ready to take off, see how the model handles on the ground by doing a few practice runs at **low speeds** on the runway. Hold “up” elevator to keep the tailwheel on the ground. If necessary, adjust the tailwheel so the model will roll straight down the runway. If you need to calm your nerves before the maiden flight, shut the engine down and bring the model back into the pits. Top off the fuel, then check all fasteners and control linkages for peace of mind.

Remember to take off into the wind. When you're ready, point the model straight down the runway, hold a bit of up elevator to keep the tail on the ground to maintain tailwheel steering, and then gradually advance the throttle. As the model gains speed, decrease up elevator, allowing the tail to come off the ground. One of the most important things to remember with a tail dragger is to always be ready to apply **right** rudder to counteract engine torque. Gain as much speed as your runway and flying site will practically allow before gently applying up elevator, lifting the model into the air. At this moment it is likely that you will need to apply more right rudder to counteract engine torque. Be smooth on the elevator stick, allowing the model to establish a **gentle** climb to a safe altitude before turning into the traffic pattern.

Flight

For reassurance and to keep an eye on other traffic, it is a good idea to have an assistant on the flight line with you. Tell him to remind you to throttle back once the plane gets to a comfortable

altitude. While full throttle is usually desirable for take off, most models fly more smoothly at reduced speeds.

Take it easy with the PT-17 Military Stearman ARF for the first few flights, gradually getting acquainted with it as you gain confidence. Adjust the trims to maintain straight and level flight. After flying around for a while, and while still at a safe altitude with plenty of fuel, practice slow flight and execute practice landing approaches by reducing the throttle to see how the model handles at slower speeds. Add power to see how she climbs as well. Continue to fly around, executing various maneuvers and making mental notes (or having your assistant write them down) of what trim or C.G. changes may be required to fine tune the model so it flies the way you like. Mind your fuel level, but use this first flight to become familiar with your model before landing.

Landing

To initiate a landing approach, lower the throttle while on the downwind leg. Allow the nose of the model to pitch downward to gradually bleed off altitude. Continue to lose altitude, but maintain airspeed by keeping the nose down as you turn onto the crosswind leg. Make your final turn toward the runway (into the wind) keeping the nose down to maintain airspeed and control. Level the attitude when the model reaches the runway threshold, modulating the throttle as necessary to maintain your glide path and airspeed. If you are going to overshoot, smoothly advance the throttle (always ready on the right rudder to counteract torque) and climb out to make another attempt. When you're ready to make your landing flare and the model is a foot or so off the deck, smoothly increase up elevator until it gently touches down. Once the model is on the runway and has lost flying speed, hold up elevator to place the tail on the ground, regaining tailwheel control.

One final note about flying your model. Have a goal or flight plan in mind for **every** flight. This can be learning a new maneuver(s), improving a maneuver(s) you already know, or learning how the model behaves in certain conditions (such as on high or low rates). This is not necessarily to improve your skills (*though it is never a bad idea!*), but more importantly so you do not surprise yourself by impulsively attempting a maneuver and suddenly finding that you've run out of time, altitude or airspeed. Every maneuver should be deliberate, not impulsive. For example, if you're going to do a loop, check your altitude, mind the wind direction (anticipating rudder corrections that will be required to maintain heading), remember to throttle back at the top, and make certain you are on the desired rates (high/low rates). A flight plan greatly reduces the chances of crashing your model just because of poor planning and impulsive moves. **Remember to think.**

Have a ball! But always stay in control and fly in a safe manner.

GOOD LUCK AND GREAT FLYING!

OTHER ITEMS AVAILABLE FROM GREAT PLANES



Great Planes Giant Super Chipmunk 1.20 ARF

Art Scholl performed airshow magic with his Super Chipmunk for over 25 years. And with the help of Great Planes' magic, you can have this scale replica ready to perform in just 12-15 hours. The trim scheme is authentic, provided by MonoKote on the built-up wings and stab and paint on the fiberglass fuselage, cowl, wheel pants and landing gear fairings. Instrument panel decals and a pilot figure provide extra "eye candy" without extra work. Routing tubes for pushrods, a 3-piece wing and a steerable tailwheel offer added ease on the ground. Dual servos on each flap, aileron and elevator half put the power to dazzle a crowd at your fingertips. **GPMA1303**

PENNZOIL® LOGO Manufactured under license by Pennzoil-Quaker State Company, 2004. Hobbico, Inc., 2904 Research Rd, Champaign, IL 61826



Futaba® 6EXA 6-Channel FM Computer Radio

The 6-channel 6EXA keeps setup simple – programming requires just 2 buttons and a data input lever. It's all-digital, so you can lock in precise settings for everything. That includes the digital trims, which offer 241 discrete settings for super-fine tuning performance. Besides essentials such as servo reversing, EPA on all six channels, a trainer system, and easy-to-read LCD screen, the 6EXA also boasts 6-model memory with reset, program mixing, throttle cut-off switch, retract switch, flap knob, audible battery power alarm, adjustable stick length, a dual-conversion, 7-channel R127DF receiver and four S3004 ball bearing servos. 72MHz. **FUTK55****

