

Matt Chapman **EAGLE 580**



Giant Scale 85–100 cc Aerobatic/3D ARF

TECHNICAL NOTICE

Page 18, Step 2

Install the canister muffler on the **right side first**. The canister muffler must be inserted into the fuselage as far back as possible. The exhaust outlet should be positioned so that it is in front of the wood former approximately 1/8" [3.2mm]. **The exhaust outlet must not touch the wood former.** The heat from the exhaust outlet may damage the wood former if it touches.

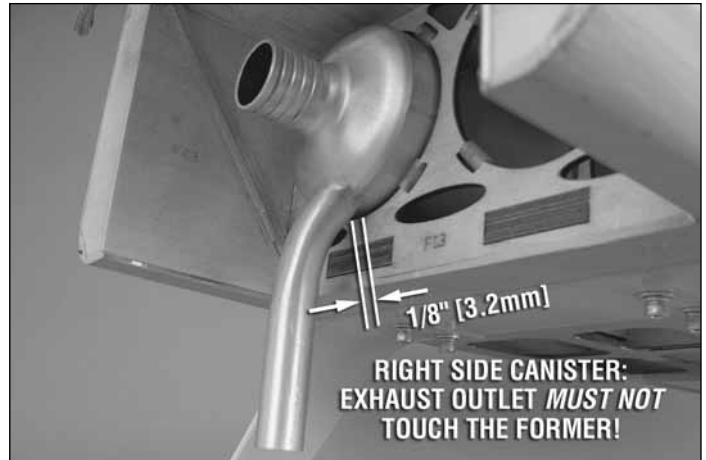

Page 19, Steps 3, 4, and 6

Step 3: Position one of the exhaust header pipes over the right cylinder's exhaust port and mark the pipe approximately 1/8" [3.2mm] forward of the canister muffler inlet pipe. Use a felt tip pen to label this as the right exhaust header pipe.

Step 4: After cutting the pipe to length, lay the right exhaust header pipe over the second exhaust header pipe, mark and cut it the same length. **Both header pipes must be the same length for the engine to operate properly.**

Step 6: Note when installing the left header pipe that the canister muffler will not be inserted as far back in the fuselage. It's more important that the header pipes **are the same length**.

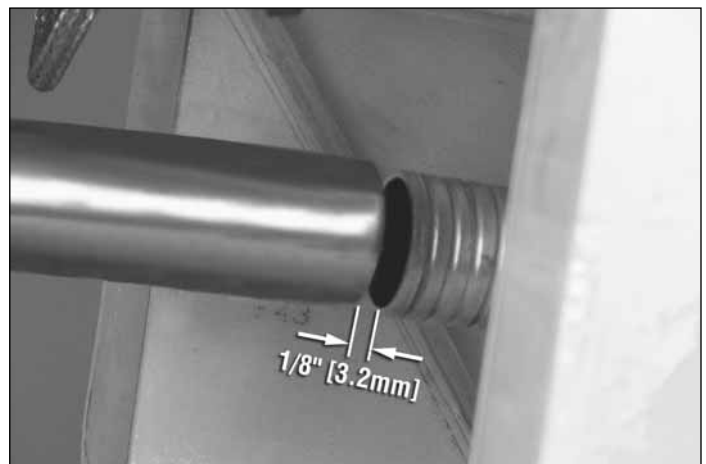

Page 21, Step 8

Before installing the spinner, check that the head of the spinner bolt fits in the end of the spinner. If it is tight, use a metal cutting file or coarse sandpaper to remove some of the knurl on the head of the bolt.

