

# U-Can-Do 3D™

## INSTRUCTION MANUAL

**A. R. F.**  
*Almost Ready to Fly*



**Wingspan:** 65 in [1651mm]  
**Wing Area:** 1072 sq in [69 dm<sup>2</sup>]  
**Weight:** 7 lbs - 7 lbs 6 oz [3175 - 3345g]  
**Wing Loading:** 15 - 15.9 oz/sq ft [46 - 48 g/dm<sup>2</sup>]  
**Length:** 69.5 in [1765mm]  
**Engine:** .61 - .91 cu in [10 - 15cc] two-stroke, .70 - .91 cu in [11 - 15cc] four-stroke

### WARRANTY

**Great Planes® Model Manufacturing Co.** guarantees this kit to be free from defects in both material and workmanship at the date of purchase. This warranty does not cover any component parts damaged by use or modification. **In no case shall Great Planes' liability exceed the original cost of the purchased kit.** Further, Great Planes reserves the right to change or modify this warranty without notice.

In that Great Planes has no control over the final assembly or material used for final assembly, no liability shall be assumed nor accepted for any damage resulting from the use by the user of the final user-assembled product. By the act of using the user-assembled product, the user accepts all resulting liability.

If the buyer is not prepared to accept the liability associated with the use of this product, the buyer is advised to return this kit immediately in new and unused condition to the place of purchase.

**READ THROUGH THIS MANUAL BEFORE STARTING CONSTRUCTION. IT CONTAINS IMPORTANT WARNINGS AND INSTRUCTIONS CONCERNING THE ASSEMBLY AND USE OF THIS MODEL.**



1610 Interstate Drive Champaign, IL 61822  
(217) 398-8970, Ext 2  
airsupport@greatplanes.com

## TABLE OF CONTENTS

<b>INTRODUCTION</b> .....	<b>2</b>
<b>SAFETY PRECAUTIONS</b> .....	<b>2</b>
<b>DECISIONS YOU MUST MAKE</b> .....	<b>3</b>
Radio Equipment.....	3
Engine Recommendations .....	3
<b>ADDITIONAL ITEMS REQUIRED</b> .....	<b>3</b>
Hardware and Accessories .....	3
Covering Accessories.....	4
Adhesives and Building Supplies .....	4
Optional Supplies and Tools.....	4
<b>IMPORTANT BUILDING NOTES</b> .....	<b>4</b>
<b>KIT CONTENTS</b> .....	<b>5</b>
<b>ORDERING REPLACEMENT PARTS</b> .....	<b>6</b>
<b>PREPARATIONS</b> .....	<b>7</b>
<b>BUILD THE WING</b> .....	<b>7</b>
Mount the Ailerons .....	7
Install the Aileron Servos and Pushrods .....	8
Mount the Wing to the Fuselage .....	10
<b>BUILD THE FUSELAGE</b> .....	<b>11</b>
Mount the Stab and Fin.....	11
Mount the Wheel Pants & Landing Gear.....	13
Mount the Engine .....	15
Mount the Cowl .....	15
Install the Tank .....	17
<b>FINAL ASSEMBLY</b> .....	<b>18</b>
Install the Remaining Servos .....	18
Mount the Canopy .....	20
Apply the Decals .....	21
<b>GET THE MODEL READY TO FLY</b> .....	<b>21</b>
Check the Control Directions .....	21
Set the Control Throws.....	21
Balance the Model (C.G.).....	21
Balance the Model Laterally.....	22
<b>PREFLIGHT</b> .....	<b>22</b>
Identify Your Model .....	22
Charge the Batteries .....	22
Balance Propellers .....	23
Ground Check .....	23
Range Check.....	23
<b>ENGINE SAFETY PRECAUTIONS</b> .....	<b>23</b>
<b>AMA SAFETY CODE</b> .....	<b>23</b>
General.....	23
Radio Control .....	24
<b>CHECKLIST</b> .....	<b>24</b>
<b>FLYING</b> .....	<b>24</b>
Takeoff .....	25
Flight.....	25
Landing.....	25
<b>PERFORMANCE SETTINGS</b> .....	<b>26</b>

## INTRODUCTION

Whether you're just learning to do basic aerobatics or are looking for a quick practice plane as a backup to your \$10,000 Unlimited aerobatic machine, U-CAN-DO 3D is just the bird you're looking for.

Large control surfaces, light wing loading and an all around performance design work together to put a fun-to-fly do-it-all 3D aerobatic machine in your hands. With the U-CAN-DO 3D on low rates, it is a perfect choice for learning to do basic aerobatics or for great Sunday fun flying. With a powerful, high torque 4-stroke such as an OS .91, the U-CAN-DO 3D provides exceptional slow speed and below-stall-speed (3D) aerobatic performance.

For the latest technical updates or manual corrections to the U-CAN-DO 3D, visit the web site listed below and select the Great Planes U-CAN-DO 3D ARF. If there is new technical information or changes to this model, a "tech notice" box will appear in the upper left corner of the page.

<http://www.greatplanes.com/airplanes/index.html>

### **PROTECT YOUR MODEL, YOURSELF & OTHERS...FOLLOW THESE IMPORTANT SAFETY PRECAUTIONS**

1. Your U-CAN-DO 3D should not be considered a toy, but rather a sophisticated, working model that functions very much like a full-size airplane. Because of its performance capabilities, the U-CAN-DO 3D 60, if not assembled and operated correctly, could possibly cause injury to yourself or spectators and damage to property.
2. You must assemble the model **according to the instructions**. Do not alter or modify the model, as doing so may result in an unsafe or unflyable model. In a few cases the instructions may differ slightly from the photos. In those instances the written instructions should be considered as correct.
3. You must take time to **build straight, true and strong**.
4. You must use an R/C radio system that is in first-class condition and a correctly sized engine and components (fuel tank, wheels, etc.) throughout the building process.
5. You must correctly install all R/C and other components so that the model operates correctly on the ground and in the air.
6. You must check the operation of the model before **every** flight to insure that all equipment is operating and that the model has remained structurally sound. Be sure to check clevises or other connectors often and replace them if they show any signs of wear or fatigue.

7. If you are not already an experienced R/C pilot, you should fly the model only with the help of a competent, experienced R/C pilot.

**8. WARNING:** The cowl and wheel pants included in this kit are made of fiberglass, the fibers of which may cause eye, skin and respiratory tract irritation. Never blow into a part to remove fiberglass dust, as the dust will blow back into your eyes. Always wear safety goggles, a particle mask and rubber gloves when grinding, drilling and sanding fiberglass parts. Vacuum the parts and work area thoroughly after working with fiberglass parts.

We, as the kit manufacturer, provide you with a top quality kit and instructions, but ultimately the quality and flyability of your finished model depends on how you build it; therefore, we cannot in any way guarantee the performance of your completed model and no representations are expressed or implied as to the performance or safety of your completed model.

**Remember: Take your time and follow the instructions to end up with a well-built model that is straight and true.**

If you have not flown this type of model before, we recommend that you get the assistance of an experienced pilot in your R/C club for your first flights. If you're not a member of a club, your local hobby shop has information about clubs in your area whose membership includes experienced pilots.

In addition to joining an R/C club, we strongly recommend you join the AMA (Academy of Model Aeronautics). AMA membership is required to fly at AMA sanctioned clubs. There are over 2,500 AMA chartered clubs across the country. Among other benefits, the AMA provides insurance to its members who fly at sanctioned sites and events. Additionally, training programs and instructors are available at AMA club sites to help you get started the right way. Contact the AMA at the address or toll-free phone number below:



**Academy of Model Aeronautics**  
5151 East Memorial Drive  
Muncie, IN 47302-9252  
Tele. (800) 435-9262  
Fax (765) 741-0057

Or via the Internet at: <http://www.modelaircraft.org>

## DECISIONS YOU MUST MAKE

This is a partial list of items required to finish the U-CAN-DO 3D that may require planning or decision-making before starting to build. Order numbers are provided in parentheses.

## Radio Equipment

4+ channel radio with 6 standard-sized servos as noted below. Note that a 6+ channel, fully computerized radio system is highly recommended for maximum flexibility and performance.

### Ailerons:

- Two ball bearing servos (50+ in oz: HCAM0170)
- One 24" y-harness (HCAM2751)

OR

- Two 6" extensions (HCAM2701) and one y-harness (HCAM2500)

### Rudder:

- One high torque servo (90+ in oz: HCAM0191)
- One 24" servo extension (HCAM2200)

### Elevator:

- Two ball bearing servos (50+ in oz: HCAM0170)
- If using a computerized radio two 24" servo extensions (HCAM2200)
- If not using a computerized radio with Ailevator programming, then a servo reversing harness is required (FUTM4150)

### Throttle:

- One servo, standard (HCAM0150)

## Engine Recommendations

.61 to .91 2-stroke, .70 to .91 4-stroke  
Appropriate props, fuel, glow plugs, etc. for your engine.

**Engine notes:** The U-Can-Do 3D will hover on all of the recommended engines. The engines on the lower end of the range will hover nicely without over-speeding the airframe in level flight. The engines on the higher end of the range will hover and give the added power to recover from unwanted attitudes, but throttle management needs to be used to keep the speed down. Whatever engine you choose, a 6 pitch prop or less is recommended.

## ADDITIONAL ITEMS REQUIRED

### Hardware and Accessories

In addition to the items listed in the "Decisions You Must Make" section, following is the list of hardware and accessories required to finish the U-CAN-DO 3D 60. Order numbers are provided in parentheses.

- Hook & Loop Velcro (GPMQ4480)
- 3' Medium fuel tubing (GPMQ4131)
- Easy Fueler™ fuel filling valve for glow fuel (GPMQ4160)
- Handy Mounts air valve, fuel filler mounts (GPMQ6000)

## Covering Accessories

- 21st Century® sealing iron (COVR2700)
- 21st Century trim seal iron (COVR2750)
- 21st Century iron cover (COVR2702)

## Adhesives and Building Supplies

In addition to common household tools and hobby tools, this is the “short list” of the most important items required to build the U-CAN-DO 3D 60. **Great Planes Pro™ CA and Epoxy glue are recommended.**

- 1/2 oz. Thin Pro CA (GPMR6001)
- 1/2 oz. Medium Pro CA+ (GPMR6007)
- 6-Minute Epoxy (GPMR6045)
- 30-Minute Epoxy (GPMR6047)
- Small T-pins (HCAR5100)
- Electric drill
- Drill bit set including (1/16" 3/32" 1/8" 5/64" and 1/2" bits)
- Small Phillips and flat blade screwdrivers (HCAR1040)
- Pliers with wire cutter (HCAR0630)
- Standard Hex wrench set (HCAR0520)

## Optional Supplies and Tools

Here is a list of optional tools mentioned in the manual that will help you build the U-CAN-DO 3D 60.

- Great Planes CG Machine™ (GPMR2400)
- Top Flite® Precision Magnetic Prop Balancer™ (TOPQ5700)
- Straightedge with scale (HCAR0475)
- Cutting mat (HCAR0456)
- Masking Tape (TOPR8018)
- CA Applicator Tips (GPMR6033)
- CA Debonder (GPMR6039)
- CA Accelerator (GPMR6034)
- Milled Fiberglass (GPMR6165)
- Microballoons (TOPR1090)
- R/C-56 Canopy Glue (JOZR5007)
- Epoxy Brushes (GPMR8060)
- Mixing Sticks (GPMR8055)
- Threadlocker (GPMR6060)
- Denatured Alcohol (for epoxy clean up)
- Hobby Knife (HCAR0105), #11 Blades (HCAR0211)
- Non-elastic monofilament or Kevlar fishing line (for stab alignment)
- Builders Triangle Set (HCAR0480) (for fin alignment)
- Easy-Touch™ Bar Sander (GPMR6170, or similar)
- Felt-Tip Marker (TOPQ2510)
- Small metal file
- Rotary tool such as Dremel®
- Rotary tool reinforced cut-off wheel (GPMR8200)
- Curved Tip Canopy Scissors for trimming plastic parts (HCAR0667)

- Dead Center™ Engine Mount Hole Locator (GPMR8130)
- Great Planes AccuThrow™ Deflection Gauge (for measuring control throws, GPMR2405)

## IMPORTANT BUILDING NOTES

- There are two types of screws used in this kit:

**Sheet metal screws** are designated by a number and a length. For example #6 x 3/4" [19mm]



*This is a number six screw that is 3/4" [19mm] long.*

**Machine screws** are designated by a number, threads per inch and a length. For example 4-40 x 3/4" [19mm]

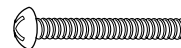

*This is a number four screw that is 3/4" [19mm] long with forty threads per inch.*

- When you see the term **test fit** in the instructions, it means that you should first position the part on the assembly **without using any glue**, then slightly modify or **custom fit** the part as necessary for the best fit.

- Whenever the term **glue** is written you should rely upon your experience to decide what type of glue to use. When a specific type of adhesive works best for that step, the instructions will make a recommendation.

- Whenever just **epoxy** is specified you may use **either** 30-minute (or 45-minute) epoxy **or** 6-minute epoxy.

- **Photos** and **sketches** are placed **before** the step they refer to. Frequently you can study photos in following steps to get another view of the same parts.

- The U-CAN-DO 3D is factory-covered with Top Flite MonoKote® film. Should repairs ever be required, MonoKote can be patched with additional MonoKote purchased separately. MonoKote is packaged in six-foot rolls, but some hobby shops also sell it by the foot. If only a small piece of MonoKote is needed for a minor patch, perhaps a fellow modeler would give you some. MonoKote is applied with a model airplane covering iron, but in an emergency a regular iron could be used. A roll of MonoKote includes full instructions for application. Following are the colors used on this model and order numbers for six foot rolls.

Jet White (TOPQ0204)  
True Red (TOPQ0227)  
Sky Blue (TOPQ0206)  
Sapphire Blue (TOPQ0226)  
Black (TOPQ0208)

## KIT CONTENTS

Before starting to build, use the **Kit Contents** list to take an inventory of this kit to make sure it is complete and inspect the parts to make sure they are of acceptable quality. If any parts are missing or are not of acceptable quality, or if you need assistance with assembly, contact **Great Planes Product Support**. When reporting defective or missing parts, use the part names exactly as they are written in the Kit Contents list on this page.

**Great Planes Product Support:**  
**Phone: (217) 398-8970**  
**Fax: (217) 398-7721**  
**E-mail: [airsupport@greatplanes.com](mailto:airsupport@greatplanes.com)**

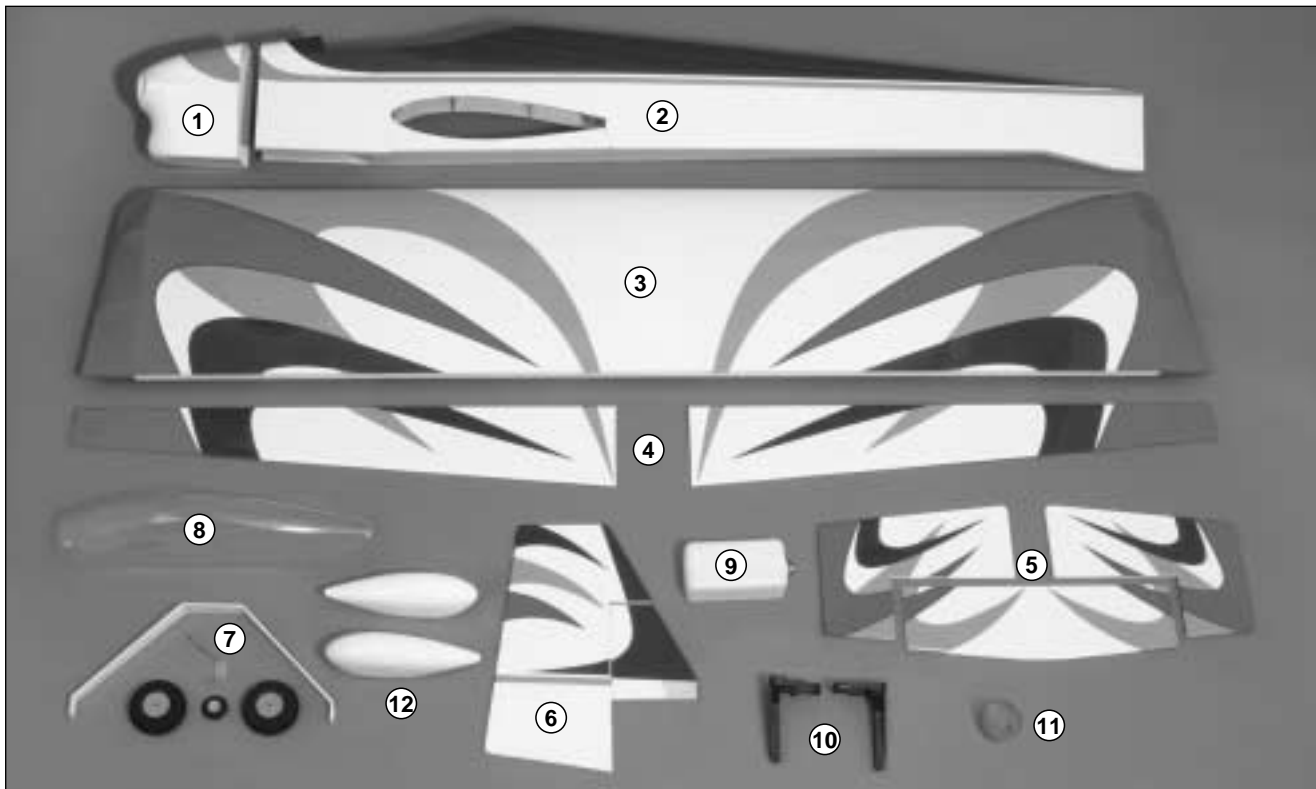

### Kit Contents (Photographed)

- |   |  |   |
|---|--|---|
| <ul style="list-style-type: none"> <li>1 Fiberglass Cowl</li> <li>2 Fuselage</li> <li>3 Wing</li> <li>4 Ailerons</li> </ul> | <ul style="list-style-type: none"> <li>5 Stab and Elevators</li> <li>6 Fin and Rudder</li> <li>7 Landing Gear</li> <li>8 Canopy</li> </ul> | <ul style="list-style-type: none"> <li>9 Fuel Tank with Hardware</li> <li>10 Adjustable Engine Mount</li> <li>11 Spinner</li> <li>12 Wheel Pants</li> </ul> |
|---|--|---|

### Kit Contents (Not Photographed)

- |   |   |  |
|---|---|--|
| <ul style="list-style-type: none"> <li>(1) 17-1/2 .074 wire (throttle pushrod)</li> <li>(2) 1/4 - 20 Blind Nuts (pre-installed in fuse)</li> <li>(1) 11-3/4" Gray plastic outer pushrod tube (throttle)</li> <li>(5) 12" .074 wire threaded one end (ailerons)</li> <li>(1) 2" x 9" hinge material</li> <li>(6) Nylon clevis (rudder, elevator, ailerons, throttle)</li> <li>(5) Faslink (rudder, elevator, ailerons)</li> <li>(2) Nylon 1/4 - 20 wing bolt (wing)</li> <li>(5) Large nylon control horn (aileron, rudder, elevator)</li> <li>(7) Silicone clevis keepers (rudder, elevator, ailerons, throttle)</li> <li>(4) 6-32 x 3/4" socket head cap screw (main gear and stab)</li> </ul> | <ul style="list-style-type: none"> <li>(4) #6 lock washers (main gear and stab)</li> <li>(4) #6 flat washers (main gear and stab)</li> <li>(4) 6-32 blind nuts (main gear and stab)</li> <li>(14) #2 x 3/8" screws (cowl, canopy, wheel pants)</li> <li>(4) #2 washers (for mounting the cowl)</li> <li>(4) 8-32 blind nuts (engine mount to firewall)</li> <li>(4) 8-32 x 3/4" socket head screws (engine to engine mount)</li> <li>(4) 8-32 x 1" socket head screws (engine mount to firewall)</li> <li>(8) #8 flat washers (mounting engine and engine mount)</li> <li>(8) #8 lock washers (mounting engine and engine mount)</li> <li>(4) 5/32" wheel collar (main wheels)</li> </ul> | <ul style="list-style-type: none"> <li>(4) 6-32 x 1/8" socket head screw (main wheels)</li> <li>(6) 2-56 x 1/2" socket head screw (rudder, elevator, ailerons)</li> <li>(4) 2-56 x 3/4" socket head screw (aileron control horns)</li> <li>(1) Brass quick connect body (throttle connection)</li> <li>(1) Nylon retainer (Throttle connection)</li> <li>(1) 4-40 x 1/4" SHCS (Throttle connection)</li> <li>(1) 3/32 wheel collar (tail wheel)</li> <li>(1) 4-40 set screw (tail wheel)</li> <li>(2) Axles</li> <li>(2) Nuts for the axles</li> </ul> |
|---|---|--|

## ORDERING REPLACEMENT PARTS

To order replacement parts for the Great Planes U-CAN-DO 3D ARF, use the order numbers in the **Replacement Parts List** that follows. Replacement parts are available only as listed. Not all parts are available separately (an aileron cannot be purchased separately, but is only available with the wing kit). Replacement parts are not available from Product Support, but can be purchased from hobby shops or mail order/Internet order firms. Hardware items (screws, nuts, bolts) are also available from these outlets. If you need assistance locating a dealer to purchase parts, visit [www.greatplanes.com](http://www.greatplanes.com) and click on "Where to Buy." If this kit is missing parts, contact **Product Support**.

### Replacement Parts List

<u>Order Number</u>	<u>Description</u>	<u>How to Purchase</u>
	Missing pieces .....	Contact Product Support
	Instruction manual.....	Contact Product Support
	Full-size plans .....	Not available
	Kit parts listed below.....	Hobby Supplier
<b>GPMA2300</b> .....	<b>Wing Kit</b> (one piece wing, ailerons, dowels and hinge material)	
<b>GPMA2301</b> .....	<b>Fuselage Kit</b> (Fuse, belly pan, (2) balsa tank holders, stab fillet, (4) cowl mounting blocks and servo tray)	
<b>GPMA2302</b> .....	<b>Tail Set</b> (stab, elevators, fin, rudder and hinge material)	
<b>GPMA2303</b> .....	<b>Landing Gear</b>	
<b>GPMA2304</b> .....	<b>Fiberglass Cowl</b>	
<b>GPMA2305</b> .....	<b>Canopy</b>	
<b>GPMA2306</b> .....	<b>Wheel Pants</b> (left and right wheel pant, (4) mounting plates)	
<b>GPMA2307</b> .....	<b>Decal Sheet</b>	
<b>GPMA2308</b> .....	<b>Tailwheel Assembly</b> (tail gear and tail wheel)	

### Metric Conversions

1/64" = .4mm	3/16" = 4.8mm	1" = 25.4mm	18" = 457.2mm
1/32" = .8mm	1/4" = 6.4mm	2" = 50.8mm	21" = 533.4mm
1/16" = 1.6mm	3/8" = 9.5mm	3" = 76.2mm	24" = 609.6mm
3/32" = 2.4mm	1/2" = 12.7mm	6" = 152.4mm	30" = 762mm
1/8" = 3.2mm	5/8" = 15.9mm	12" = 304.8mm	36" = 914.4mm
5/32" = 4mm	3/4" = 19mm	15" = 381mm	

**To convert inches to millimeters, multiply inches by 25.4**

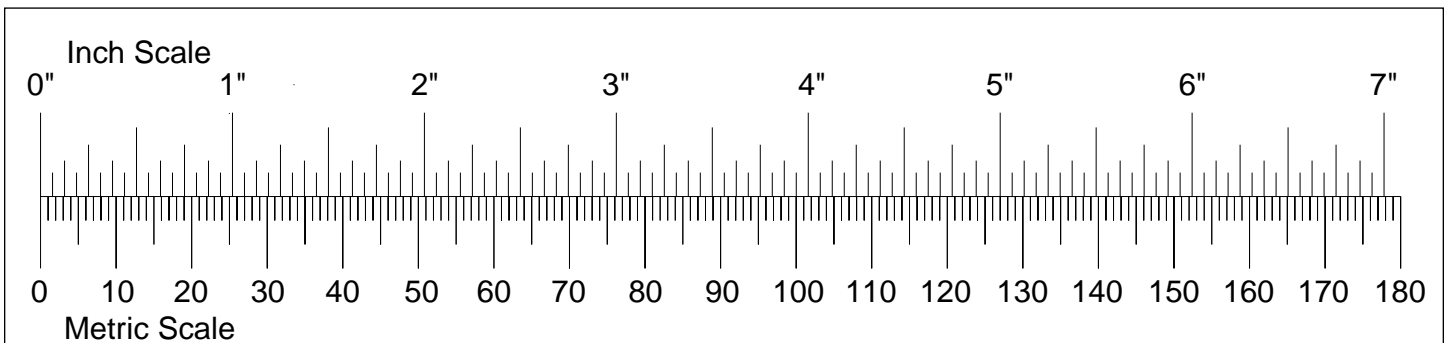

## PREPARATIONS

1. If you have not yet done so already, remove the major parts of the kit from the box (wings, fuse, wheel pants, cowl, tail parts, etc.) and inspect them for damage. If any parts are damaged or missing, contact Product Support at the address or telephone number on page 5.



2. Remove the masking tape and separate the ailerons from the wing, the rudder from the fin and the elevators from the stab. Where necessary, use a covering iron with a covering sock to tighten the covering that may have loosened during storage or from removing the masking tape. Apply pressure over sheeted areas and the servo openings to **thoroughly** bond the covering to the wood.

## BUILD THE WING

### Mount the Ailerons

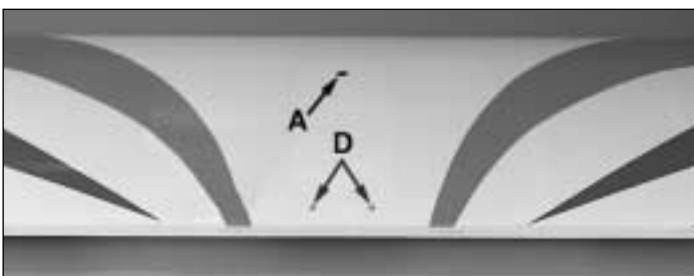

1. Trim the covering on the wing from
- A) The servo wire hole in the top center of the wing;
  - B) Both servo openings;
  - C) Both dowel holes;
  - D) Top and Bottom wing-bolt holes.

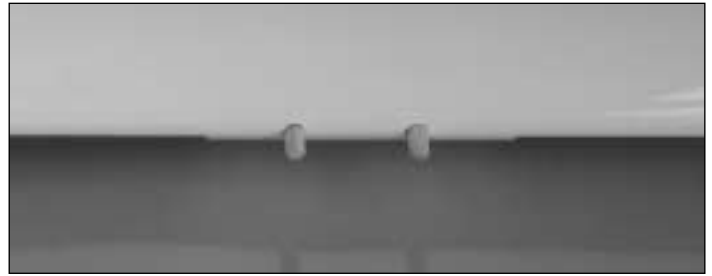

2. Use your sanding bar to round one end of each of the 5/16" x 1-3/4" [8 x 70mm] wing dowels. Use epoxy to glue the two wing dowels into the wing, with the non-rounded end in the wing.

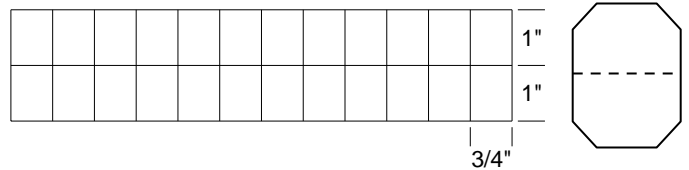

3. Cut eight 3/4" x 1" [19 x 25mm] hinges from the 2" x 9" [50 x 230mm] CA hinge strip. Snip the corners off so they go in easier.



4. Test fit the hinges in the hinge slots of the aileron and the wing. If you have difficulty inserting the hinges, insert a #11 blade into the slot and **carefully** move it back and forth to slightly widen the slot.



5. Test fit the ailerons to the wing with the hinges. Use a fine-point ballpoint pen to mark the wing and ailerons at the middle of each hinge.

- ❑ 6. Separate the ailerons from the wing and take out all the hinges.



- ❑ 7. Drill a  $\frac{3}{32}$ " [2.4mm] hole,  $\frac{1}{2}$ " [13mm] deep at the marks you made in the center of each hinge slot. This space will allow the CA to "wick" in. Follow with a #11 blade to clean out the slots. **Hint:** If available, use a high-speed rotary tool to drill the holes.

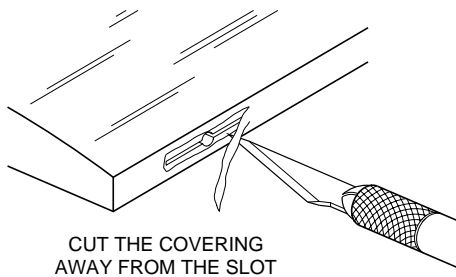

- ❑ 8. Cut a small strip of covering from both sides of each hinge slot. If this is not done the covering may interfere with the penetration of the CA into the slot and may also interfere with the free movement of the aileron.

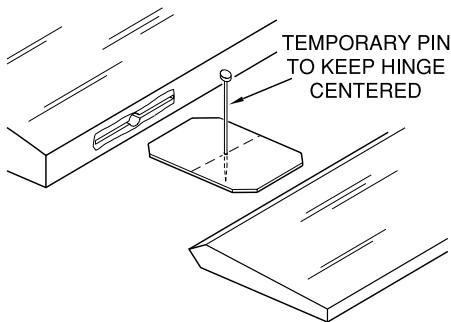

- ❑ 9. Stick a pin through the center of each hinge. Fit the ailerons to the wing with the hinges. The pin will keep the hinge centered. Remove the pins from the hinges. Adjust the ailerons so there is a small gap—just enough to see light through or to slip a piece of paper through—between the aileron and the wing.

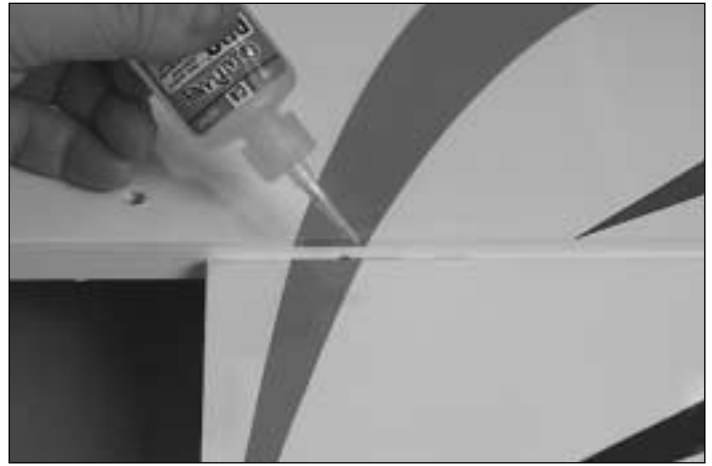

- ❑ 10. Apply six drops of thin CA to the top and bottom of each hinge. **Do not** use CA accelerator. After the CA has fully hardened, test the hinges by pulling on the ailerons.

### *Install the Aileron Servos and Pushrods*

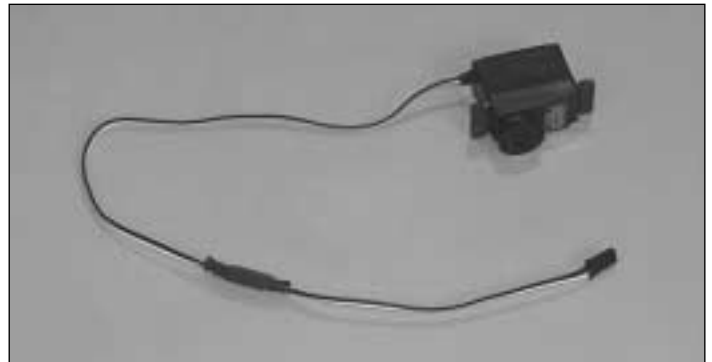

- ❑ 1. Add servo extensions to the two aileron servos, so that the total length of the leads will be at least 18" [460mm] from the servo to the end of the extension. Using tape or heat shrink tubing, securely attach the servo extension to the servo. **Note:** If you are using Futaba® servos, a 6" [150mm] lead is perfect.

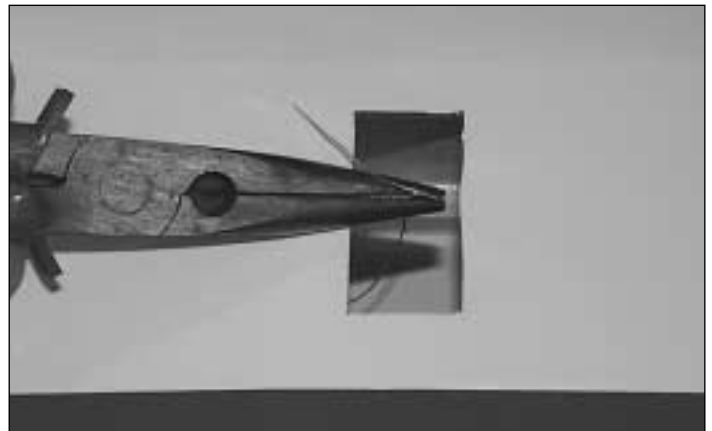

- ❑ 2. Using needle nose pliers, pull the string out of the right wing's servo hole. Tie the string to the end of the servo lead. **Note:** Take care not to pull the string loose from the other side of the wing.



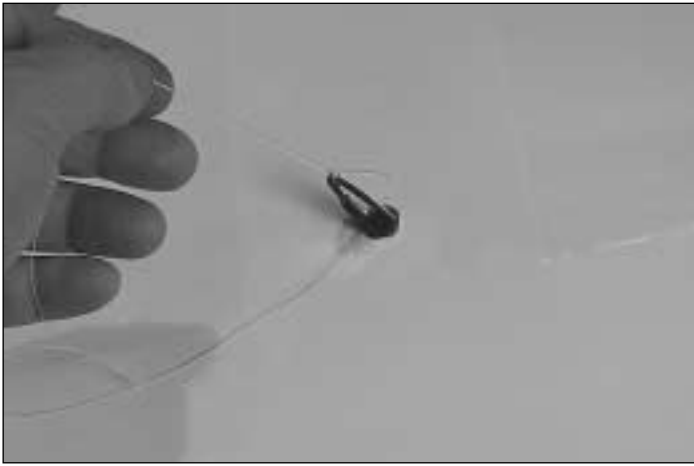

3. Pull the center of the string out of the servo hole in the wing. It might take a little fishing to get it out. Take your time. Use the string to pull the servo wire through the wing, being careful to not pull the string loose from the other end taped in the wing. Fit the servo in the wing.

4. Drill 1/16" [1.6mm] holes through the servo mount for the servo screws. Add a few drops of thin CA to the holes and allow to fully harden. Mount the aileron servo using the hardware that came with the servo.

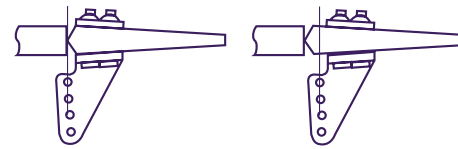
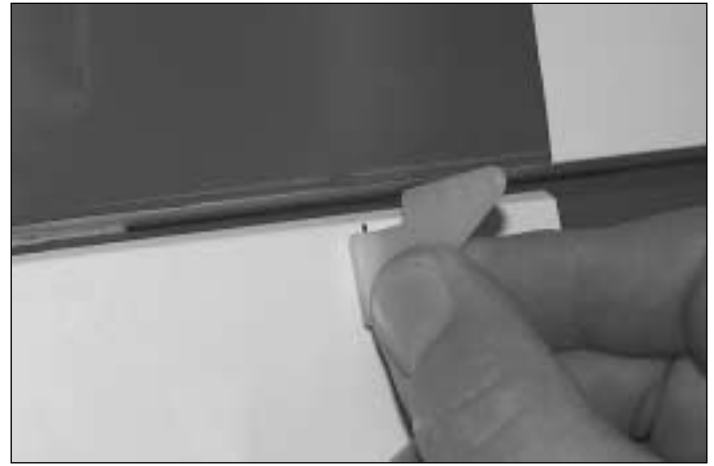

Correct

Incorrect

6. Center a control horn on the mark you made. Drill two 1/16" [1.6mm] holes through the aileron for mounting the control horn. Mount the control horn using the 2-56 x 3/4" [19mm] socket head cap screws (SHCS) with the nylon backing plate on the top-side of the aileron. **Note:** Turning a 2-56 tap through the back plate holes makes it easier to get the SHCS to thread into them.

7. Thread a clevis 25 turns onto the end of one 12" [305mm] pushrod. Slip a silicone retainer over the pushrod down to the clevis.

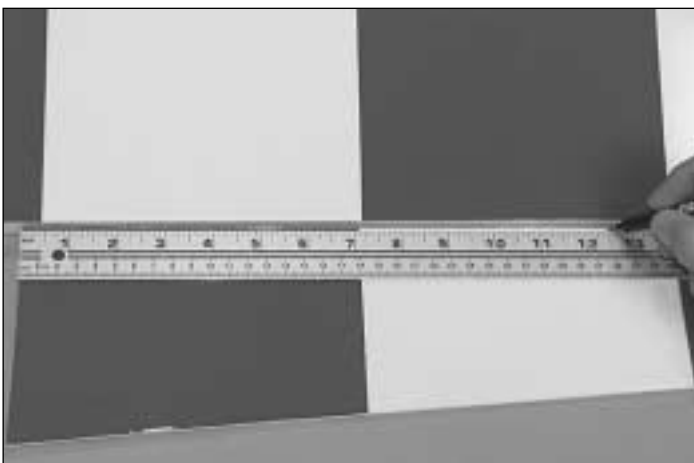

5. Make a mark on the bottom L.E. of the right aileron 12-1/2" [315mm] from the inboard end of the aileron.

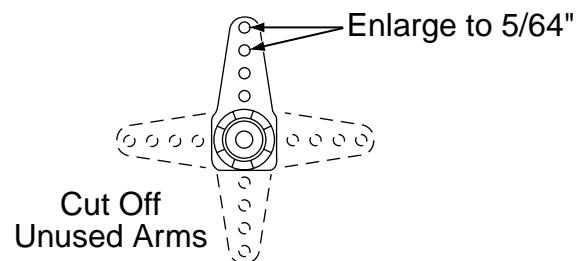

8. Make a one-arm servo arm by cutting three arms off a four-arm servo arm. Enlarge the holes in the arm with a Hobbico® Servo Horn Drill (or a #48 or 5/64" [2mm] drill bit) so the pushrod will fit. Connect the servo lead to the receiver. Turn on the transmitter and receiver to center the servo. Place the servo arm on the servo so it is pointing straight towards the wing tip.

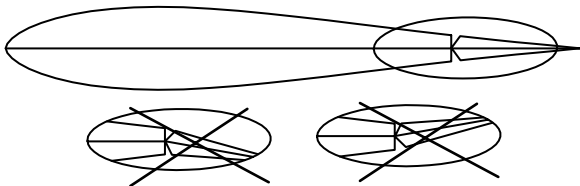
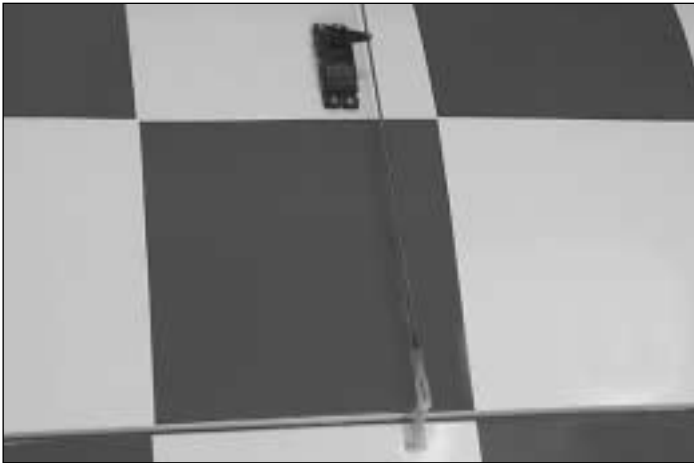
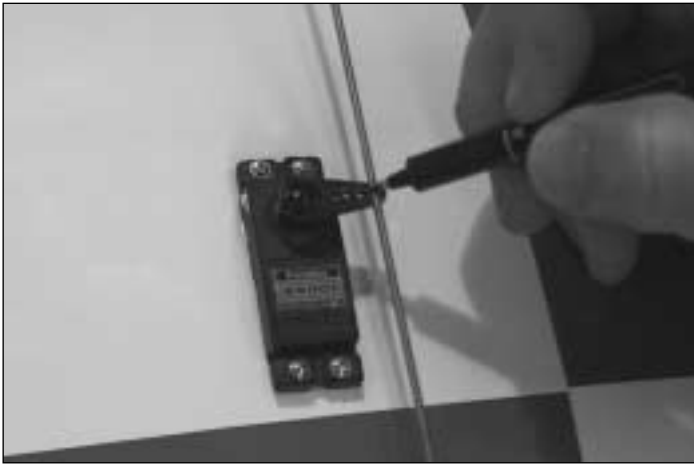

9. Attach the clevis with pushrod to the outer hole of the control horn. Hold the aileron straight with the wing and mark the pushrod where it crosses the servo arm. Bend the pushrod 90 degrees away from the wing on the mark you made.

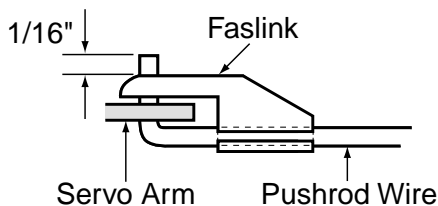

10. Attach the pushrod to the control horn as shown in the sketch. Cut off the excess pushrod. Be certain to leave 1/16" [1.6mm] of wire protruding from the Faslink as shown in the sketch.

11. Repeat steps 2-10 for the other left side of the wing.



12. Slide a silicone retainer over the two servo wires so they won't fall back into the wing.

### Mount the Wing to the Fuselage

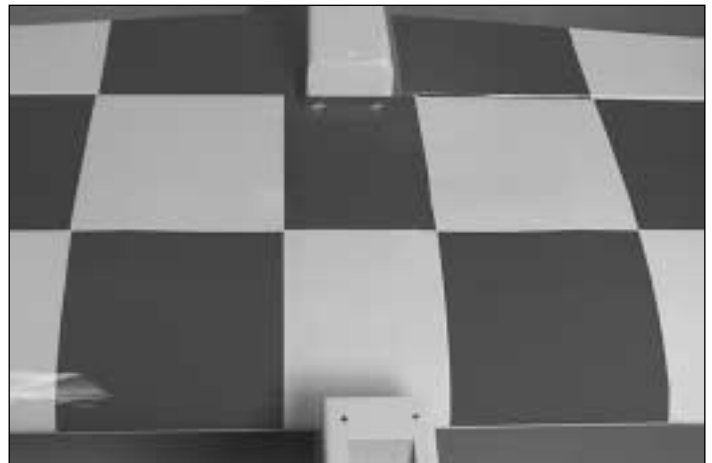

1. Mount the wing to the fuse with the two 1/4-20 x 2" [51mm] nylon bolts.

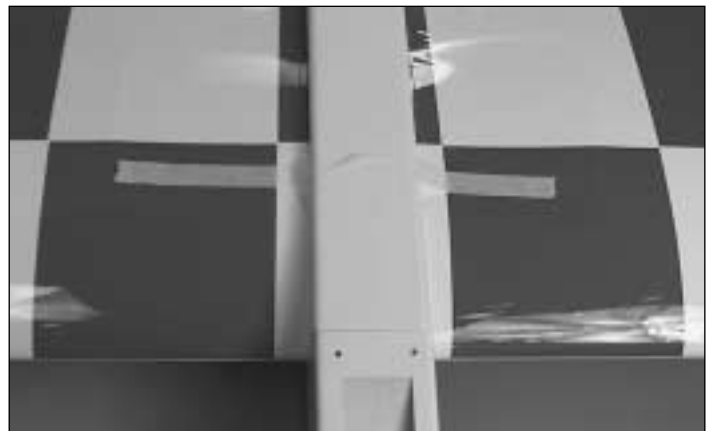

2. Trim the two bolt holes in the belly pan. Using 6-minute epoxy, glue the belly pan to the wing, being careful not to glue the belly pan or wing to the fuse. Tape the belly pan to the wing until the epoxy has cured.

3. Remove the two 1/4-20 x 2" [51mm] nylon bolts. Remove the wing. **Note:** The wing might press out of the fuse a little hard the first few times.

## BUILD THE FUSELAGE

### Mount the Stab and Fin

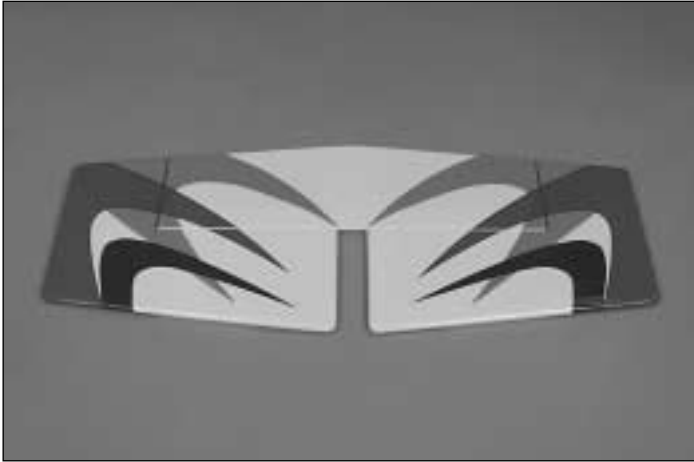

- 1. Attach the elevators to the stab with the same hinging technique used for the ailerons.

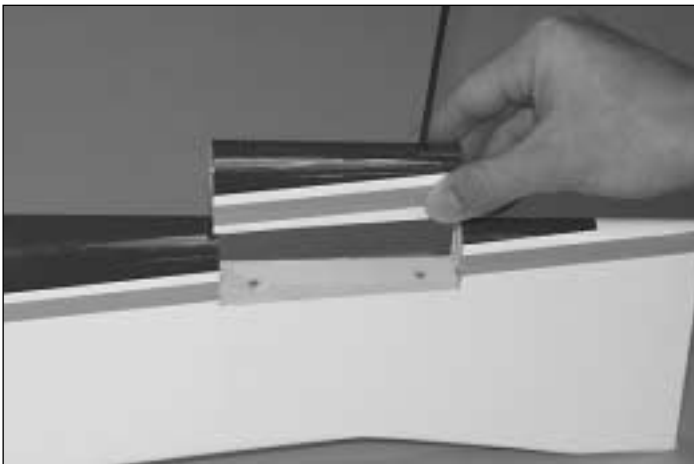

- 2. Using a 7/64" hex wrench, remove the two 6-32 x 3/4" [19mm] socket head cap screws from the stab fillet.

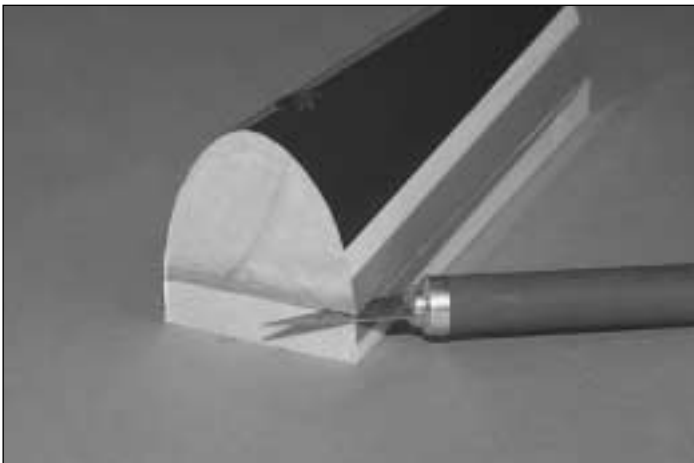

- 3. Use a #11 blade to cut between the false stab and the stab fillet. **Note:** The false stab is used in building the fuse. It can also be used for transport to keep the stab fillet in place.

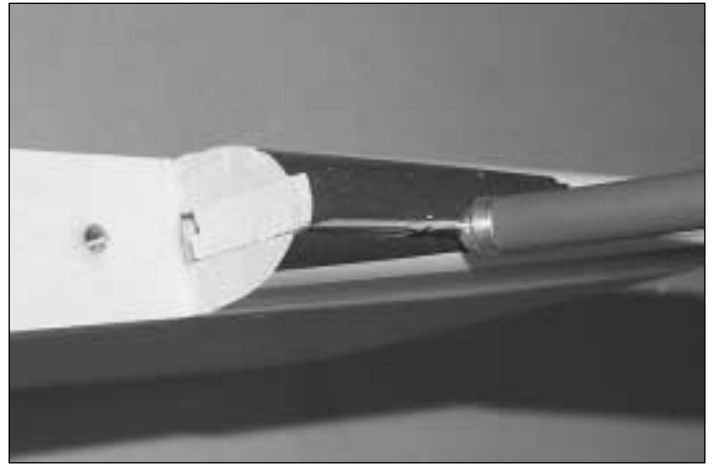

- 4. Use a #11 blade to remove the false fin from the fin slot. **Note:** It may be necessary to pry up slightly on the front of the fin fillet to remove it.



- 5. Fit the fin in place and mark the covering on the fin where it contacts the fuse.

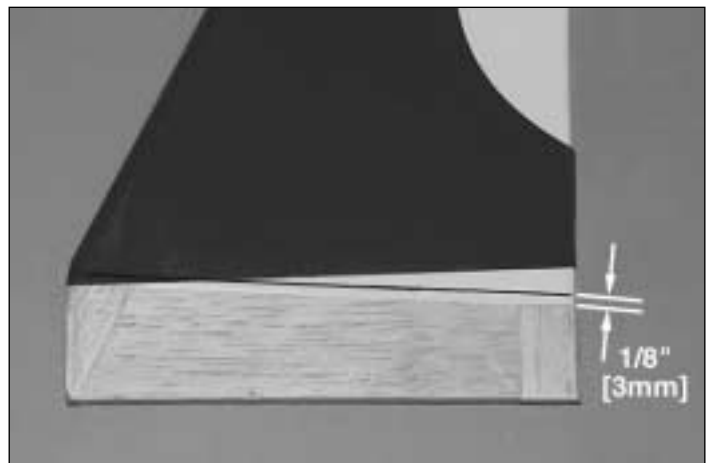

- 6. Trim the covering 1/8" [3mm] below the lines you made on the fin. Be very careful not to cut into the fin itself. Wipe away the marks on the fin you made in the previous step. The epoxy used in the next step will make removing those lines difficult.



### How to cut covering from balsa.



To avoid cutting into the balsa, use a soldering iron instead of a hobby knife to cut the covering. The tip of the soldering iron doesn't have to be sharp, but a fine tip does work best. Allow the iron to heat fully. Use a straightedge to guide the soldering iron at a rate that will just melt the covering and not burn into the wood. The hotter the soldering iron, the faster it must move to melt a fine cut.

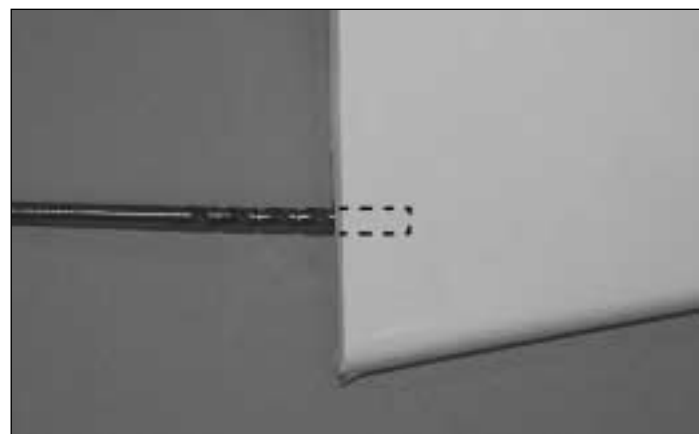

7. Apply 6-minute epoxy to all joining surfaces of the fin. Fit the fin in place, aligning the TE of the fin with the TE of the fuse.

9. Use a hobby knife or a 5/32" [4mm] brass tube sharpened on the end to cut a groove in the leading edge of the rudder to accommodate the nylon tail gear bearing. Drill a 1/8" [3.2mm] hole into the rudder for the "arm" portion of the tail gear wire.

10. Carefully apply a small dab of petroleum jelly to the top and bottom of the tail gear bearing where the tail gear wire goes through the bearing to keep glue from entering. Apply 30-minute epoxy inside the slot in the fuselage for the tail gear bearing and to the hinge of the tail gear bearing. Install the tail gear bearing and wipe away any excess epoxy.

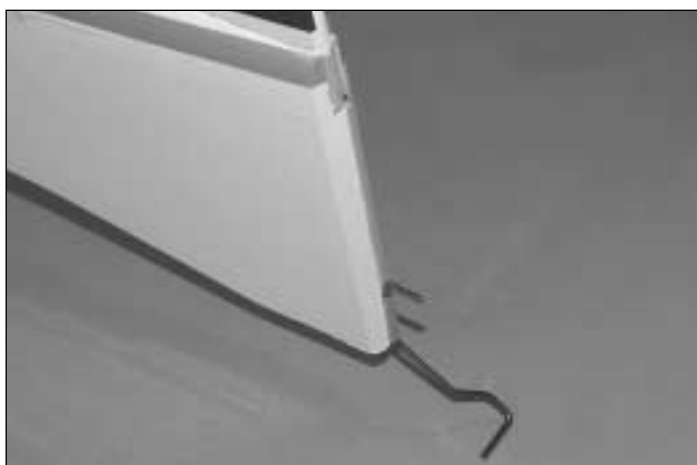

8. Test fit the nylon tail gear bearing with the tail gear wire into the slot in the rear of the fuse.



11. Test fit the rudder to the tail gear and the fin using three CA hinges. Repeat until you are satisfied that the rudder fits properly. Apply epoxy in the rudder for the tail gear wire. Fit the rudder with hinges to the fuse and wipe away residual epoxy. Apply 6 drops of thin CA to both sides of each hinge.



12. Trim the two bolt holes in the stab covering. Bolt the stab and stab fillet in place, using the two 6-32 x 3/4" [19mm] SHCS. **NOTE: If you don't plan on removing the stab, glue the bolts in with medium CA. If you do plan on removing it, make sure to check the tightness of the screws often.**

13. Attach the 1-1/4" [32mm] tail wheel with the 3/32" wheel collar and the 4-40 set screw.

### Mount the Wheel Pants & Landing Gear

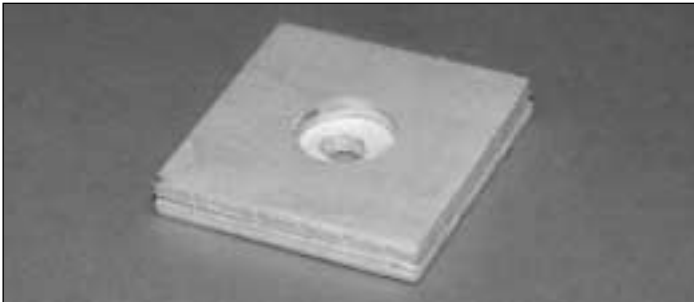

1. Glue one 3/32" x 1-1/8" x 1-1/8" [2.4 x 28 x 28mm] plywood wheel pant mount with a 3/16" [4.8mm] hole to a 3/32" x 1-1/8" x 1-1/8" [2.4 x 28 x 28mm] plywood wheel pant mount with a 1/2" [13mm] hole. Make two sets of these.

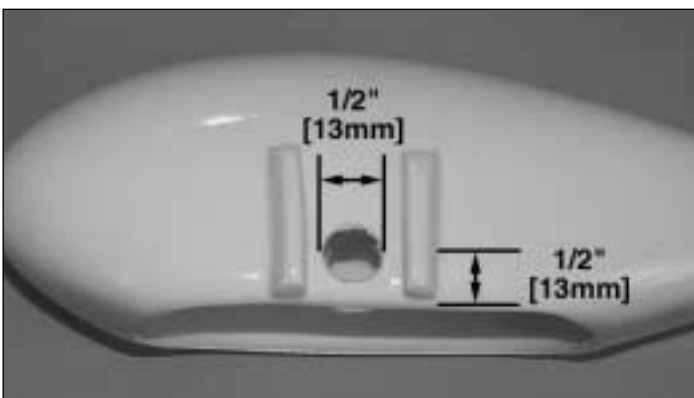

2. Make a mark on the right wheel pant centered between the wheel pant supports and 1/2" [13mm] up from

the bottom edge. Use a high-speed rotary tool with a cutting bit or a hobby knife to cut a 1/2" [13mm] hole centered on the mark.



3. Round the bottom edge of the wheel pant so it fits in the pant when the 1/2" [13mm] hole in the mount is centered over the hole in the pant. Glue the mount to the pant with 30-minute epoxy. The inside of the wheel pant mount has the 1/2" [13mm] hole. **Hint:** for the most secure bond, add microballoons (TOPR1090) or milled glass fibers (GPMR6165) to the epoxy.



4. Use a metal saw or a high-speed rotary tool with a reinforced cut-off wheel to cut 5/16" [8mm] from one of the bolt-on axles. Mount the axle to the landing gear with the nut.

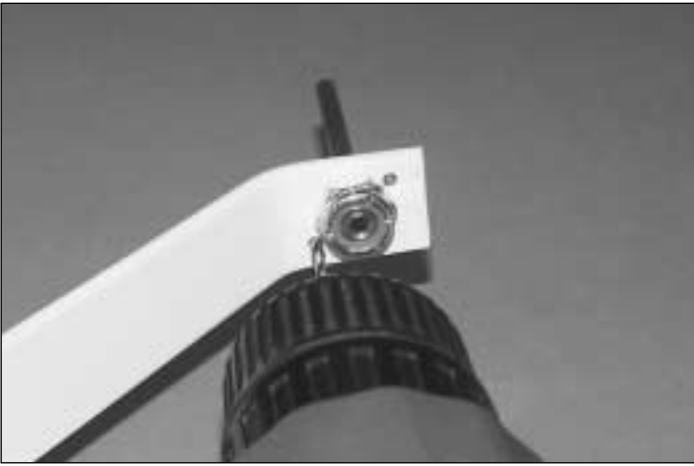

5. Drill 3/32" [2.4mm] holes through the landing gear diagonally on both sides of the axle nut.

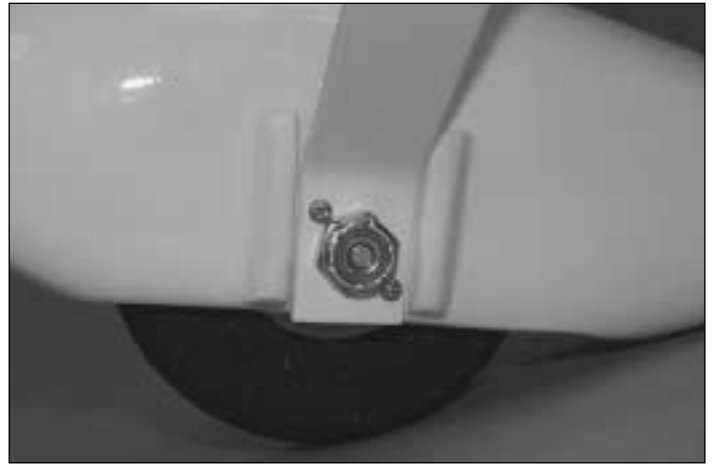

8. Drill two 1/16" [1.6mm] holes through the pant using the holes in the gear as a guide.



9. Fasten the wheel pants to the landing gear with two #2 x 3/8" screws. Remove the set screws in the wheel collars and add a drop of oil to the axle and the wheel. Add a drop of threadlocker to the set screws, install them into the wheel collars and securely tighten. **Note:** Double check that the wheel spins freely.

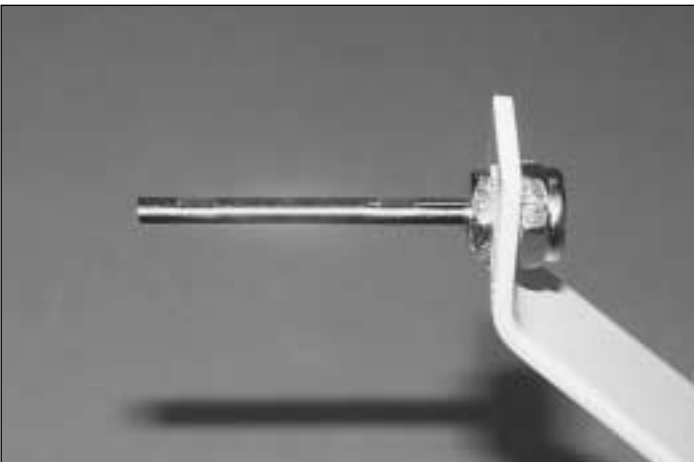

6. Temporarily slide the wheel pant, a wheel collar, wheel and second wheel collar onto the axle. Determine where the set screws for the wheel collars will be positioned on the axle. Remove the wheel and pant, and then file flat spots on the bottom of the axle for the set screws in the wheel collars.

10. Return to step 2 and mount the other wheel and pant to the left landing gear the same way.

7. Mount the wheel to the axle and tighten the set screws.

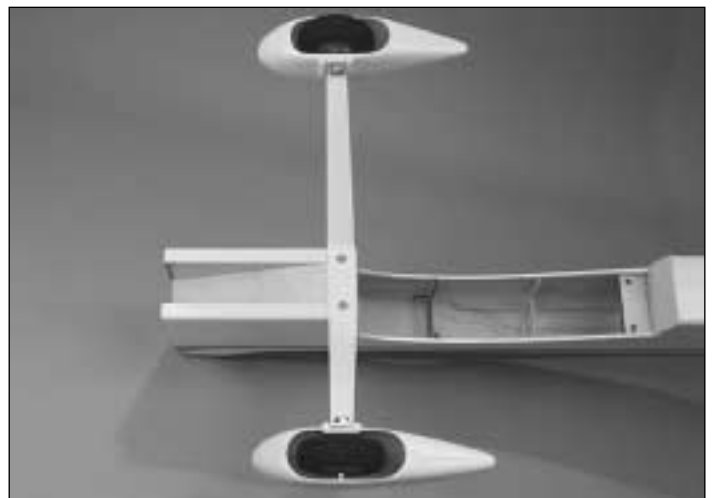

11. Mount the landing gear to the fuse with two 6-32 x 3/4" SHCS, #6 flat washers and #6 lock washers.

## Mount the Engine



- ❑ 1. Draw a vertical line on the firewall using the embossed lines as a guide. **Note:** This line is offset to the left side of the fuse so that the spinner will be on the center-line of the fuse.

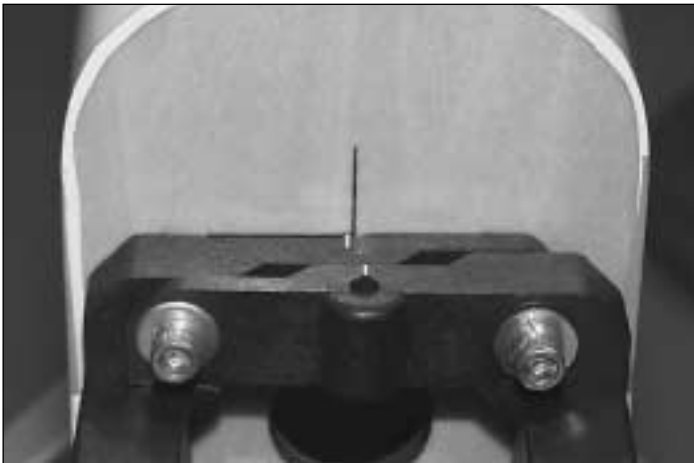

- ❑ 2. Trim the spreader bars from both halves of the engine mount. Mount the engine mount to the firewall with four 8-32 x 1" [25mm] SHCS, #8 flat washers and #8 lock washers, but do not fully tighten the bolts.

- ❑ 3. Adjust the width of the mount to fit the engine. Center the molded-in "tick" marks on the engine mount equally to the left and right of the vertical line on the firewall. Tighten the mounting bolts.

- ❑ 4. Place the back plate of the spinner on the engine. **Note:** Depending on your engine choice, it may be necessary to enlarge the hole in the back plate.

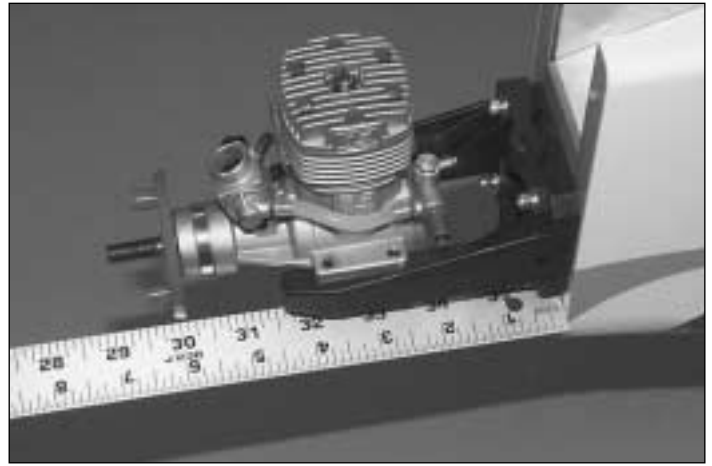

- ❑ 5. Use small clamps or another method to temporarily secure the engine to the mount with the back plate of the spinner 5-7/8" [150mm] from the firewall. Use the Great Planes Dead Center™ Engine Mount Hole Locator (GPMR8130) or your preferred method to mark the engine mount holes onto the engine mount.

- ❑ 6. Remove the engine from the mount. Drill #29 holes through the mount at the marks you made. Tap 8-32 threads into the mount. Mount the engine to the mount with four 8-32 x 3/4" [19mm] SHCS, #8 flat washers and #8 lock washers.

## Mount the Cowl

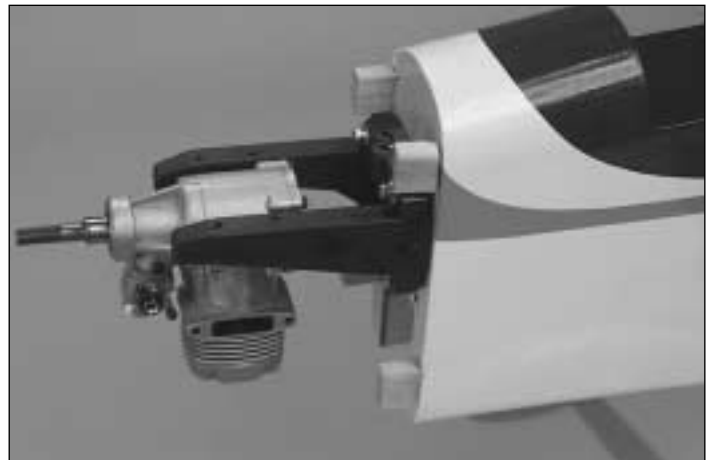

- ❑ 1. Use epoxy to glue the four 3/8" x 3/4" x 3/4" [9.5 x 19 x 19mm] maple cowl mounting blocks to the firewall in approximately the locations shown.

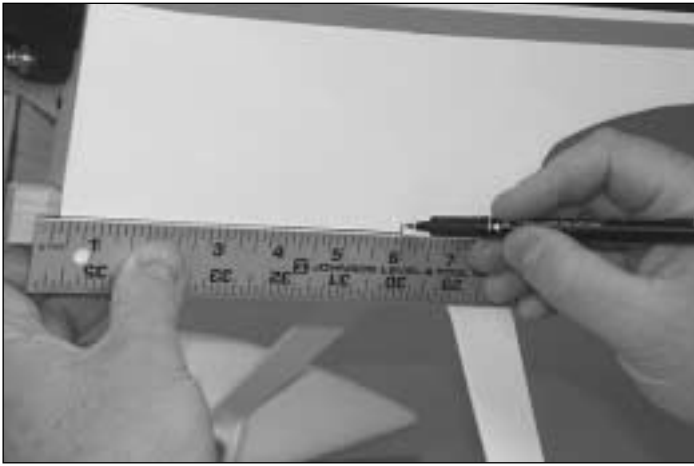

❑ 2. Hold a ruler to the fuse centered on one of the cowl mounting blocks. Use a felt-tip pen to draw a line directly onto the fuse along the straightedge.

❑ 3. Mark a reference point on the end of the line exactly 6" [152mm] from the center of the cowl mounting block.

❑ 4. Mark the location of the remaining three cowl mounting blocks the same way.

❑ 5. Place the cowl on the fuse. Mount the spinner and prop to the engine. Position the cowl on the fuse so it is in alignment with the spinner. Be certain there is at least a 3/32" [2.5mm] gap between the front of the cowl and the back plate of the spinner. It may be helpful to have an assistant hold the cowl for you.

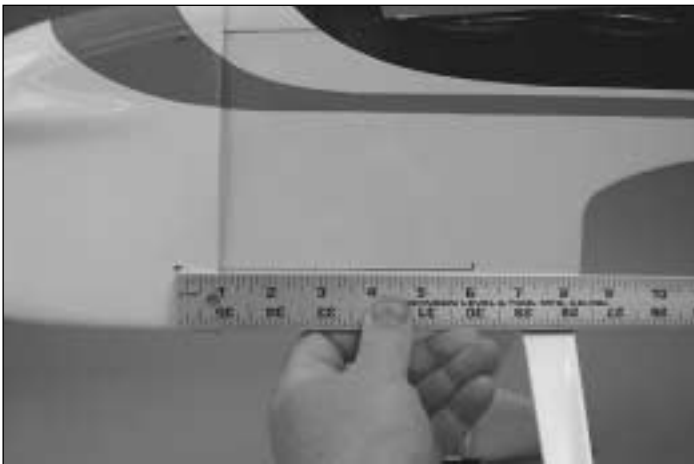

❑ 6. Align the ruler with the line on the fuselage. Mark the center of the cowl mounting block on the cowl 6" from the reference point. Drill a 1/16" [1.6mm] hole through the cowl and the mounting block at the mark. Enlarge the hole in the **cowl only** with a 3/32" [2.4mm] drill. Mount the cowl to the block with a #2 x 3/8" [9.5mm] screw and a #2 washer

❑ 7. With your assistant holding the cowl in position, mark, drill and mount the cowl to the three remaining cowl mounting blocks the same way

❑ 8. Remove the cowl. Clean the reference marks off the fuse.



9. Use the filler valve mount from a Great Planes Handy Mounts set (GPMQ6000), or fashion a mount from 1/8" [3mm] plywood (not included) for the fuel filler valve. A Great Planes Easy-Fueler for glow fuel was used on this model (GPMQ4160, not included with this kit). Use epoxy to securely glue the filler valve mount to the firewall in a location where the filler valve will be accessible outside the cowl when it's time to fuel the engine.



❑ 10. Use thin cardboard or plastic to make templates for the muffler, mixture screw, filler valve and glow plug cutouts in the cowl. Tape the template(s) to the fuselage accurately indicating the positions. **Note:** With this engine installation we installed the muffler bolts through two 1/4" [6mm] holes in the right side of the cowl. This is the time to decide how you are going to mount your muffler.



❑ 11. Remount the cowl under the templates. Use a felt-tip pen to transfer the holes in the template onto the cowl. Remove the templates and the cowl.



- 12. Cut out the holes in the cowl with a high-speed rotary tool and a small cutting bit.

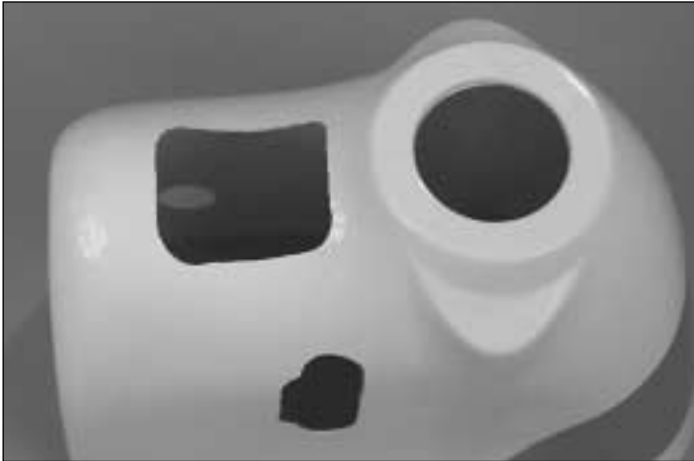

- 13. Cut the air opening in the front of the cowl as shown. **Note:** Do not remount the cowl. The tank, fuel line and throttle pushrod still need to be installed.

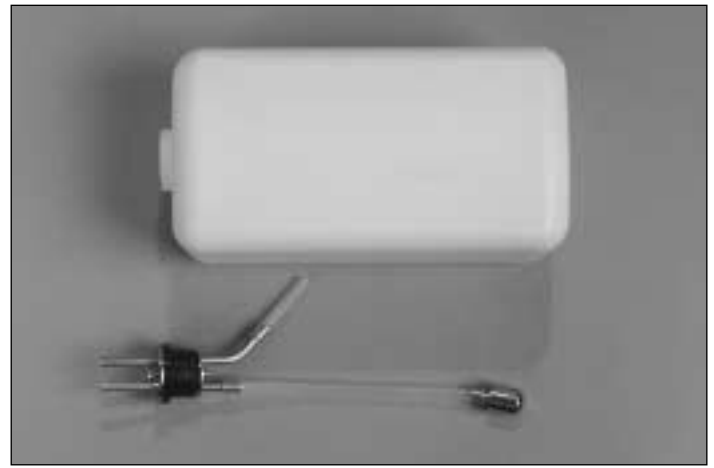

- 2. Arrange the stopper and tubes as shown in the photo, then insert them into the tank. Tighten the screw to expand the stopper, thus sealing the tank. Be certain the fuel line weight (clunk) at the end of the fuel line inside the tank does not contact the rear of the tank. Otherwise, the line may become stuck above the fuel level and discontinue fuel flow. Remember (or use a felt-tip pen to mark) which tube is the fuel pick-up tube and which tube is the vent (that will be connected to the pressure fitting on the engine's muffler).

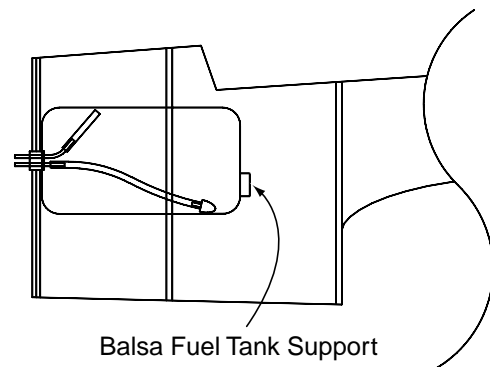

### Install the Tank

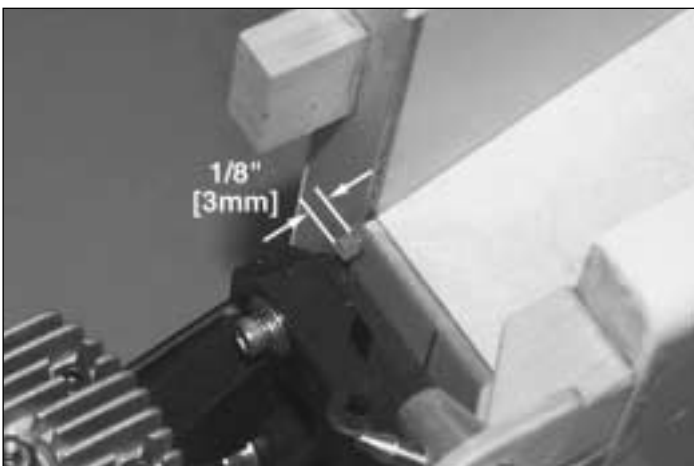

- 1. Roughen the outside of the 11-3/4" [300mm] gray pushrod outer tube with coarse sand paper. Fit the tube through the firewall and the second former leaving 1/8" [3mm] protruding from the firewall. Glue the tube to the firewall and the second former in the fuse with thin CA.

- 3. Install the tank in the fuse. Fit the neck through the hole in the firewall. Be certain the vent tube inside the tank is pointing upward.



- 4. Glue a 5/16" x 3/4" x 3" [8 x 19 x 80mm] balsa block to the fuse to hold the tank in place.

## FINAL ASSEMBLY

### Install the Remaining Servos

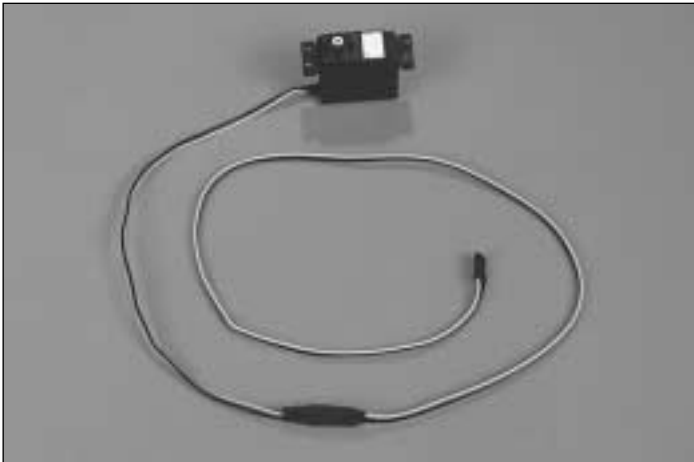

1. Add servo extensions to the three tail servos so that the total length of each lead will be at least 36" (914mm) from the servo to the end of the extension. Using tape or heat shrink tubing, securely attach the servo extension to the servo. **Note:** Use 24" [600mm] extensions with Futaba servos to get the 36" [914mm] length.

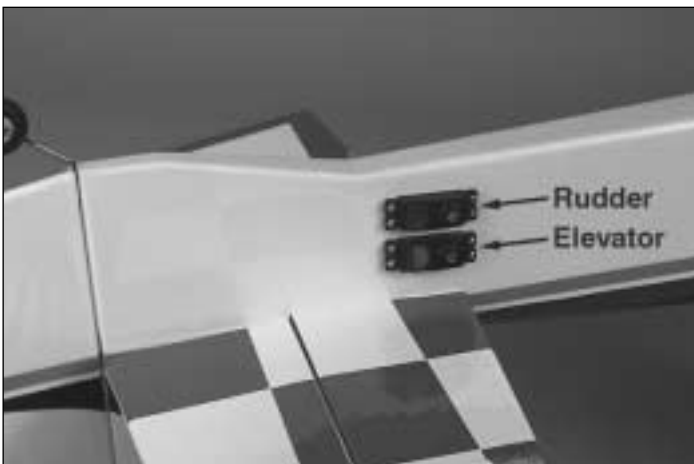

2. Trim the covering from the three tail servo holes. Fit the servos in place. **Note:** The servo leads need to go forward in the fuse to the wing opening.

3. Drill 1/16" [1.6mm] holes through the servo mount for the servo screws. Add a few drops of thin CA to the holes and allow to fully harden. Mount the tail servos using the hardware that came with the servo.



4. Make a mark on the bottom L.E. of each elevator 1/2" [13mm] from the inboard edge of each elevator. Position the control horn centered over the mark. Mark the hole locations on the elevator.

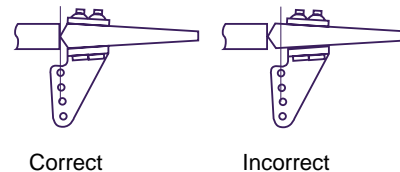
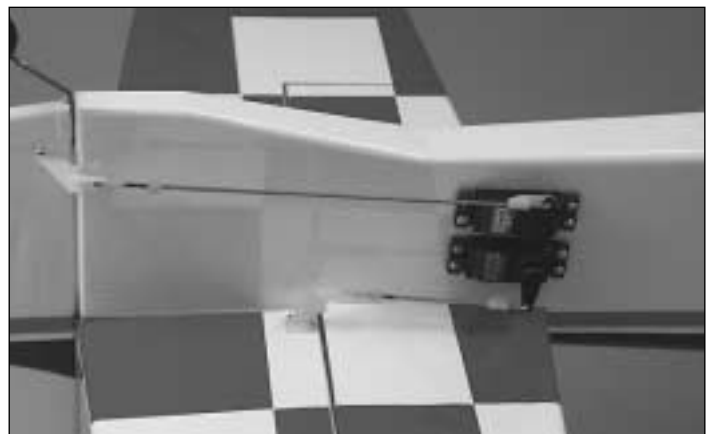

5. Drill 1/16" [1.6mm] holes through the elevators for mounting the control horns with 2-56 x 1/2" SHCS [socket head cap screws], then mount the control horn using the screws and the nylon backing plate on the top-side of the elevators. **Note:** Turning a 2-56 tap through the back plate holes makes it easier to get the socket head cap screws to thread into them.

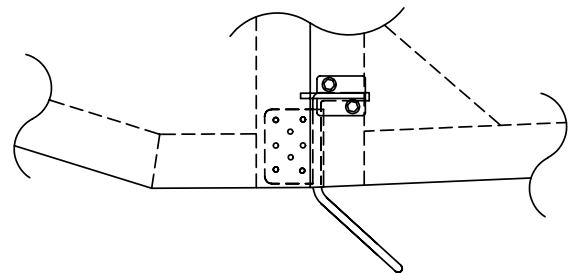

6. Mount the rudder control horn the same as the elevators', positioning it so that it captures the tail gear wire in the rudder.

❑ 7. Thread a clevis 25 turns onto one end of each of the three 12" [305mm] pushrods. Slip a silicone retainer over the clevises.

❑ 8. Make three one-arm servo arms. Enlarge the holes in the arm with a Hobbico Servo Horn Drill (or a #48 or 5/64" (2mm) drill bit) so the pushrod will fit.

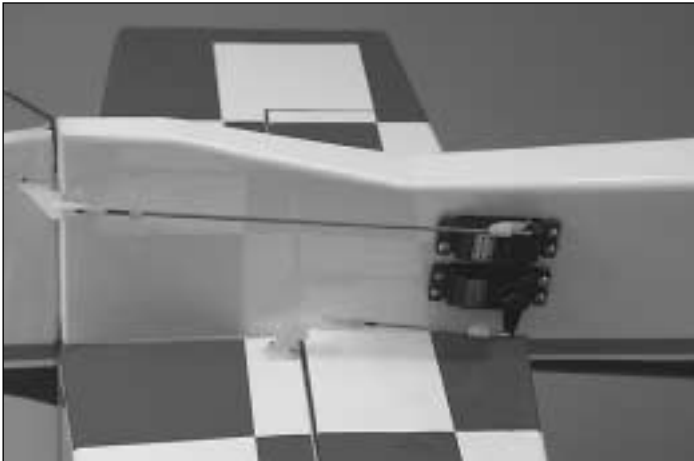

Use these photos for the next three steps. **NOTE:** The photos depict a radio setup that does not have mixing. If your radio has twin elevator mixing, mount both servo arms towards the stab.

❑ 9. Connect the servo leads to the receiver. Turn on the transmitter and receiver to center the servos. Attach the servo arms to the servos 90 degrees to the servo.

❑ 10. Attach the clevises with pushrods to the control horns. Hold the control surfaces straight and mark the pushrods where they cross the servo arms. Bend the pushrods 90 degrees away from the fuse on the marks you made. Turn the receiver and transmitter off.

❑ 11. Attach the pushrods to the control horns as shown. Trim the pushrod, being certain to leave 1/16" [1.6mm] of wire protruding from the Faslinks.



❑ 12. Screw a clevis 10 turns onto the end of the 17-1/2" [445mm] throttle pushrod. Bend the pushrod as necessary for a smooth action.



❑ 13. Glue the servo tray in place with medium CA, as shown in the photo. Fit the throttle servo in the tray but do not screw it in place at this time.



❑ 14. Connect the throttle pushrod to the throttle servo with the screw-lock connector.

❑ 15. Let the pushrod locate the servo in the tray. Mount the servo to the servo tray with the hardware provided with your servo.

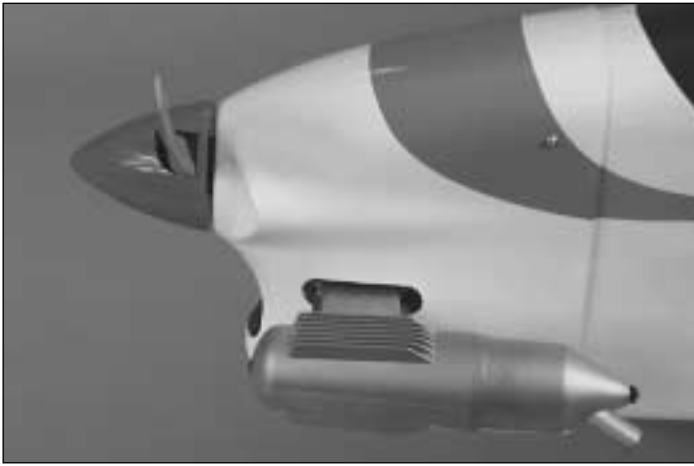

❑ 16. Route the fuel lines as needed and mount the cowl, prop, muffler and spinner.



❑ 17. Wrap the battery pack and receiver in at least 1/4" [6mm] of R/C foam rubber and install them in the fuselage. On our model with the O.S. MAX .61 FX, the battery and receiver were mounted where shown in the photo to minimize the amount of tail weight required to balance the model at the correct C.G. Securely hold the battery pack and receiver in position with the 5/16" x 3/4" x 3" [8 x 19 x 80mm] balsa block glued between the fuse sides. Simply stuffing the receiver and battery pack in place with additional foam rubber is not a secure method of holding them in place.

❑ 18. Mount the receiver on/off switch. A Great Planes Switch & Charge Jack Mounting Set (GPMM1000), not included, was used on this model. Be certain it is in a location away from the engine exhaust.

❑ 19. Extend the receiver antenna and guide it out of the fuselage. Connect it to a pin pressed into the bottom of the fuse. Be certain there is a strain relief on the antenna to keep stress off the solder joint inside the receiver. On our prototype we drilled a 3/32" [2.4mm] hole through the bottom sheeting aft of the wing opening and routed the antenna through the hole. The end of the antenna was connected to a hook made from a cut-off servo arm connected to a small rubber band and the tail gear.

## Mount the Canopy

❑ 1. Use curved-tip scissors to cut out the canopy along the cut line. True the edges by sanding with medium-grit sandpaper.



❑ 2. Place the canopy on the cockpit. Use a fine-point felt-tip pen to lightly trace the outline of the canopy onto the fuse. **Option:** Four #2 x 3/8" [9.5mm] screws are provided if you prefer to make the canopy removable.

❑ 3. Remove the canopy. Use a pin to poke several holes through the covering all the way around the cockpit 3/32" [2.4mm] inside the line you marked. These holes will help the glue adhere to the cockpit when it's time to glue the canopy on. Use a tissue dampened with alcohol to wipe away the ink line.



❑ 4. Wash the canopy in warm, soapy water. Glue the canopy to the fuse with R/C-56 Canopy Glue (JOZR5007). CA could be used, but great care must be taken not to fog the canopy or use too much CA which could run onto the canopy or the covering. Canopy glue provides working time and can be wiped away with a damp tissue before it dries. Use rubber bands, weights, tape or whatever method appropriate to hold the canopy to the cockpit until the glue dries.

## Apply the Decals

1. Use scissors or a sharp hobby knife to cut the decals from the sheet.
2. Be certain the model is clean and free from oily fingerprints and dust. Prepare a dishpan or small bucket with a mixture of liquid dish soap and warm water—about one teaspoon of soap per gallon of water. Submerge the decal in the soap and water and peel off the paper backing. **Note:** Even though the decals have a “sticky-back” and are not the water transfer type, submersing them in soap & water allows accurate positioning and reduces air bubbles underneath.
3. Position decal on the model where desired. Holding the decal down, use a paper towel to wipe most of the water away.
4. Use a piece of soft balsa or something similar to squeegee remaining water from under the decal. Apply the rest of the decals the same way.

## GET THE MODEL READY TO FLY

### Check the Control Directions

1. Turn on the transmitter and receiver and center the trims. If necessary, remove the servo arms from the servos and reposition them so they are centered. Reinstall the screws that hold on the servo arms.
2. With the transmitter and receiver still on, check all the control surfaces to see if they are centered. If necessary, adjust the clevises on the pushrods to center the control surfaces.

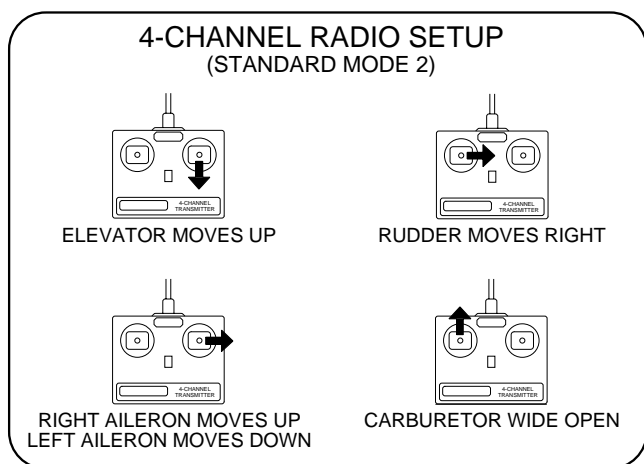

3. Make certain that the control surfaces and the carburetor respond in the correct direction as shown in the diagram. If any of the controls respond in the wrong direction, use the servo reversing in the transmitter to reverse the servos connected to those controls. Be certain the control surfaces have remained centered. Adjust if necessary.

## Set the Control Throws

Use a ruler to accurately measure and set the control throw of each control surface as indicated in the chart that follows. If your radio does not have dual rates, we recommend setting the throws at the low rate settings. **NOTE:** The throws are measured at the widest part of the elevators, rudder and ailerons.

### We recommend the following control surface throws:

	High Rate	Low Rate
<b>ELEVATOR:</b>	1-1/8" [28mm] up 1-1/8" [28mm] down	3/4" [19mm] up 3/4" [19mm] down
<b>RUDDER:</b>	2-1/4" [57mm] right 2-1/4" [57mm] left	1-1/4" [31mm] right 1-1/4" [31mm] left
<b>AILERONS:</b>	1-3/8" [35mm] up 1-3/8" [35mm] down	7/8" [22mm] up 7/8" [22mm] down

### 3D Control Throws

**NOTE:** The 3D control throws are only meant to be used for extreme aerobatics. These are not meant for normal flying. Be confident using your dual rate switches before utilizing these rates.

<b>ELEVATOR:</b>	3" [75mm] up 3" [75mm] down
<b>RUDDER:</b>	4" [100mm] right 4" [100mm] left
<b>AILERONS:</b>	2-1/8" [55mm] up 2-1/8" [55mm] down

**IMPORTANT:** The U-CAN-DO 3D has been **extensively** flown and tested to arrive at the throws at which it flies best. Flying your model at these throws will provide you with the greatest chance for successful first flights. If, after you have become accustomed to the way the U-CAN-DO 3D flies, you would like to change the throws to suit your taste, that is fine. However, too much control throw could make the model difficult to control, so remember, “more is not always better.”

## Balance the Model (C.G.)

More than any other factor, the **C.G.** (balance point) can have the **greatest** effect on how a model flies and may determine whether or not your first flight will be successful. If you value this model and wish to enjoy it for many flights, **DO NOT OVERLOOK THIS IMPORTANT PROCEDURE.** A model that is not properly balanced will be unstable and possibly unflyable.

At this stage the model should be in ready-to-fly condition with all of the systems in place including the engine, landing gear, covering and the radio system.

- ❑ 1. Use a felt-tip pen or 1/8"-wide tape to accurately mark the C.G. on the top of the wing. **The C.G. is located 4-7/8" [124mm] back from the leading edge of the wing.**

This is where your model should balance for your first flights. Later, you may wish to experiment by shifting the C.G. up to 3/8" [9mm] forward or 1/2" [13mm] back to change the flying characteristics. Moving the C.G. forward may improve the smoothness and stability, but it may then require more speed for takeoff and make it more difficult to slow for landing. Moving the C.G. aft makes the model more maneuverable, but could also cause it to become too difficult for you to control. In any case, start at the location we recommend and do not at any time balance your model outside the recommended range.

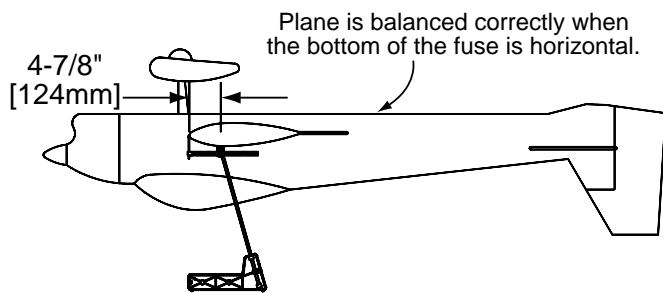

- ❑ 2. With the wing attached to the fuselage, all parts of the model installed (ready to fly) and an empty fuel tank, place the model upside-down on a Great Planes CG Machine, or lift it upside-down at the balance point you marked.

- ❑ 3. If the tail drops, the model is "tail heavy" and the battery pack and/or receiver must be shifted forward or weight must be added to the nose to balance. If the nose drops, the model is "nose heavy" and the battery pack and/or receiver must be shifted aft or weight must be added to the tail to balance. If possible, relocate the battery pack and receiver to minimize or eliminate any additional ballast required. If additional weight is required, nose weight may be easily added by using a "spinner weight" (GPMQ4645 for the 1 oz. weight, or GPMQ4646 for the 2 oz. weight). If spinner weight is not practical or is not enough, use Great Planes (GPMQ4485) "stick-on" lead. A good place to add stick-on nose weight is to the firewall (don't attach weight to the cowl—it is not intended to support weight). Begin by placing incrementally increasing amounts of weight on the bottom of the fuse over the firewall until the model balances. Once you have determined the amount of weight required, it can be permanently attached. If required, tail weight may be added by cutting open the bottom of the fuse and gluing it permanently inside.

**Note:** Do not rely upon the adhesive on the back of the lead weight to permanently hold it in place. Over time, fuel and exhaust residue may soften the adhesive and cause the weight to fall off. Use #2 sheet metal screws, RTV silicone or epoxy to permanently hold the weight in place.

- ❑ 4. **IMPORTANT:** If you found it necessary to add any weight, recheck the C.G. after the weight has been installed.

### ***Balance the Model Laterally***

- ❑ 1. With the wing level, have an assistant help you lift the model by the engine propeller shaft and the bottom of the fuse under the TE of the fin. Do this several times.
- ❑ 2. If one wing always drops when you lift the model, it means that side is heavy. Balance the airplane by adding weight to the other wing tip. **An airplane that has been laterally balanced will track better in loops and other maneuvers.**

## ***PREFLIGHT***

### ***Identify Your Model***

No matter if you fly at an AMA sanctioned R/C club site or if you fly somewhere on your own, you should always have your name, address, telephone number and AMA number on or inside your model. It is **required** at all AMA R/C club flying sites and AMA sanctioned flying events. Fill out the identification tag on the decal sheet and place it on or inside your model.

### ***Charge the Batteries***

Follow the battery charging instructions that came with your radio control system to charge the batteries. You should always charge your transmitter and receiver batteries the night before you go flying and at other times as recommended by the radio manufacturer.

**NOTE:** Checking the condition of your receiver battery pack is **highly recommended**. All battery packs, whether it's a trusty pack you've just taken out of another model, or a new battery pack you just purchased, should be cycled, noting the discharge capacity. Oftentimes, a weak battery pack can be identified (and a valuable model saved!) by comparing its actual capacity to its rated capacity. Refer to the instructions and recommendations that come with your cycler. If you don't own a battery cycler, perhaps you can have a friend cycle your pack and note the capacity for you.

## Balance Propellers

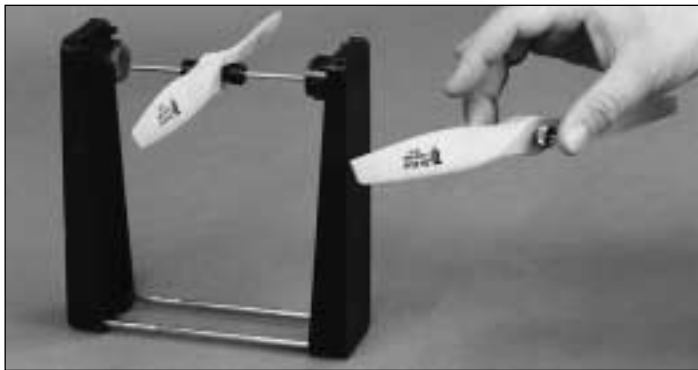

Carefully balance your propeller and spare propellers before you fly. An unbalanced prop can be the single most significant cause of vibration that can damage your model. Not only will engine mounting screws and bolts loosen, possibly with disastrous effect, but vibration may also damage your radio receiver and battery. Vibration can also cause your fuel to foam, which will, in turn, cause your engine to run hot or quit.

We use a Top Flite® Precision Magnetic Prop Balancer™ (TOPQ5700) in the workshop and keep a Great Planes Fingertip Prop Balancer (GPMQ5000) in our flight box.

## Ground Check

**If the engine is new, follow the engine manufacturer's instructions to break-in the engine.** After break-in, confirm that the engine idles reliably, transitions smoothly and rapidly to full power and maintains full power indefinitely. After you run the engine on the model, inspect the model closely to make sure all screws remained tight, the hinges are secure, the prop is secure and all pushrods and connectors are secure.

## Range Check

Ground check the operational range of your radio before the first flight of the day. With the transmitter antenna collapsed and the receiver and transmitter on, you should be able to walk at least 100 feet away from the model and still have control. Have an assistant stand by your model and, while you work the controls, tell you what the control surfaces are doing. Repeat this test **with the engine running** at various speeds with an assistant holding the model, using hand signals to show you what is happening. If the control surfaces do not respond correctly, **do not fly!** Find and correct the problem first. Look for loose servo connections or broken wires, corroded wires on old servo connectors, poor solder joints in your battery pack or a defective cell, or a damaged receiver crystal from a previous crash.

## ENGINE SAFETY PRECAUTIONS

**Failure to follow these safety precautions may result in severe injury to yourself and others.**

Keep all engine fuel in a safe place, away from high heat, sparks or flames, as fuel is very flammable. Do not smoke near the engine or fuel; and remember that engine exhaust gives off a great deal of deadly carbon monoxide. Therefore **do not run the engine in a closed room or garage.**

Get help from an experienced pilot when learning to operate engines.

Use safety glasses when starting or running engines.

Do not run the engine in an area of loose gravel or sand; the propeller may throw such material in your face or eyes.

Keep your face and body as well as all spectators away from the plane of rotation of the propeller as you start and run the engine.

Keep these items away from the prop: loose clothing, shirt sleeves, ties, scarfs, long hair or loose objects such as pencils or screwdrivers that may fall out of shirt or jacket pockets into the prop.

Use a "chicken stick" or electric starter to start the engine. Do not use your fingers to flip the propeller. Make certain the glow plug clip or connector is secure so that it will not pop off or otherwise get into the running propeller.

Make all engine adjustments from behind the rotating propeller.

The engine gets hot! Do not touch it during or right after operation. Make sure fuel lines are in good condition so fuel will not leak onto a hot engine, causing a fire.

To stop a glow engine, cut off the fuel supply by closing off the fuel line or following the engine manufacturer's recommendations. Do not use hands, fingers or any other body part to try to stop the engine. Do not throw anything into the propeller of a running engine.

## AMA SAFETY CODE (EXCERPT)

Read and abide by the following Academy of Model Aeronautics Official Safety Code:

### General

1. I will not fly my model aircraft in sanctioned events, air shows, or model flying demonstrations until it has been proven to be airworthy by having been previously successfully flight tested.

2. I will not fly my model aircraft higher than approximately 400 feet within 3 miles of an airport without notifying the airport operator. I will give right of way to and avoid flying in the proximity of full scale aircraft. Where necessary an observer shall be used to supervise flying to avoid having models fly in the proximity of full scale aircraft.

3. Where established, I will abide by the safety rules for the flying site I use and I will not willfully and deliberately fly my models in a careless, reckless and/or dangerous manner.

7. I will not fly my model unless it is identified with my name and address or AMA number, on or in the model.

9. I will not operate models with pyrotechnics (any device that explodes, burns, or propels a projectile of any kind).

## Radio Control

1. I will have completed a successful radio equipment ground check before the first flight of a new or repaired model.

2. I will not fly my model aircraft in the presence of spectators until I become a qualified flier, unless assisted by an experienced helper.

3. I will perform my initial turn after takeoff away from the pit or spectator areas and I will not thereafter fly over pit or spectator areas, unless beyond my control.

4. I will operate my model using only radio control frequencies currently allowed by the Federal Communications Commission.

## CHECK LIST

During the last few moments of preparation your mind may be elsewhere anticipating the excitement of the first flight. Because of this, you may be more likely to overlook certain checks and procedures that should be performed before the model is flown. To help avoid this, a checklist is provided to make sure these important areas are not overlooked. Many are covered in the instruction manual, so where appropriate, refer to the manual for complete instructions. Be sure to check the items off as they are completed (that's why it's called a *check list!*).

1. Fuelproof all areas exposed to fuel or exhaust residue such as the cowl ring, cowl mounting blocks, wing saddle area, etc.

2. Check the C.G. according to the measurements provided in the manual.

3. Be certain the battery and receiver are securely mounted in the fuse. Simply stuffing them into place with foam rubber is not sufficient.

4. Extend your receiver antenna and make sure it has a strain relief inside the fuselage to keep tension off the solder joint inside the receiver.

5. Balance your model *laterally* as explained in the instructions.

6. Use threadlocking compound to secure critical fasteners such as the set screws that hold the wheel axles to the struts, screws that hold the carburetor arm (if applicable), screw-lock pushrod connectors, etc.

7. Add a drop of oil to the axles so the wheels will turn freely.

8. Make sure all hinges are **securely** glued in place.

9. Reinforce holes for wood screws with thin CA where appropriate (servo mounting screws, cowl mounting screws, etc.).

10. Confirm that all controls operate in the correct direction and the throws are set up according to the manual.

11. Make sure there are silicone retainers on all the clevises and that all servo arms are secured to the servos with the screws included with your radio.

12. Secure connections between servo wires and Y-connectors or servo extensions and the connection between your battery pack and the on/off switch with vinyl tape, heat shrink tubing or special clips suitable for that purpose.

13. Make sure any servo extension cords you may have used do not interfere with other systems (servo arms, pushrods, etc.).

14. Secure the pressure tap (if used) to the muffler with high temp RTV silicone, thread locking compound or J.B. Weld.

15. Make sure the fuel lines are connected and are not kinked.

16. Balance your propeller (and spare propellers).

17. Tighten the propeller nut and spinner.

18. Place your name, address, AMA number and telephone number on or inside your model.

19. Cycle your receiver battery pack (if necessary) and make sure it is fully charged.

20. If you wish to photograph your model, do so before your first flight.

21. Range check your radio when you get to the flying field.

## FLYING

The U-Can-Do 3D is a great-flying model that flies smoothly and predictably. The U-Can-Do 3D does not, however, possess the self-recovery characteristics of a primary R/C trainer and should be flown only by experienced R/C pilots.

Whether you are looking to practice new 3D maneuvers and don't want to risk your competition aircraft, or are just starting to learn the most basic aerobatics, the U-Can-Do 3D is a great choice. Regardless of your skill level, be sure your first flight begins with low rates (yes, even in a crosswind) and that you gradually expand your flight, adding one new maneuver at a time.

Take offs, landings and most of your normal flights should be flown on low rates. (If your radio does not have dual rates, be sure to set the model up on the low rates provided.) The high rates on this model are meant **ONLY** for use when doing 3D aerobatics – maneuvers performed while the model is flying slower than its normal stall speed. That includes maneuvers as simple as a stall turn, or as complex as harrier rolls.



Don't get spoiled by how incredibly well the U-Can-Do 3D hangs and torque rolls! Most models take an enormous amount of work to keep the model stationary in a hanger, but the unique design of U-Can-Do 3D helps lock it solid in position and torque roll and hang with relative ease.

### Fuel Mixture Adjustments

A fully cowled engine may run at a higher temperature than an un-cowled engine. For this reason, the fuel mixture should be richened so the engine runs at about 200 rpm below peak speed. By running the engine slightly rich, you will help prevent dead-stick landings caused by overheating.

**CAUTION** (THIS APPLIES TO ALL R/C AIRPLANES): If, while flying, you notice any unusual sounds, such as a low-pitched "buzz," this may indicate control surface *flutter*. Because flutter can quickly destroy components of your airplane, any time you detect flutter you must **immediately** cut the throttle and land the airplane! Check all servo grommets for deterioration (this may indicate which surface fluttered) and make sure all pushrod linkages are secure and free of play. If the control surface fluttered once, it probably will flutter again under similar circumstances unless you can eliminate the free-play or flexing in the linkages. Here are some things which can cause flutter: Excessive hinge gap; Not mounting control horns solidly; Poor fit of clevis pin in horn; Side-play of pushrod in guide tube caused by tight bends; Poor fit of Z-bend in servo arm; Insufficient glue used when gluing in the elevator joiner wire; Excessive *play* or *backlash* in servo gears; and Insecure servo mounting.

## Takeoff

Before you get ready to takeoff, see how the model handles on the ground by doing a few practice runs at **low speeds** on the runway. Hold "up" elevator to keep the tail wheel on the ground. If necessary, adjust the tail wheel so the model will roll straight down the runway. If you need to calm your nerves before the maiden flight, shut the engine down and bring the model back into the pits. Top off the fuel, then check all fasteners and control linkages for peace of mind.

Remember to takeoff into the wind. When you're ready, point the model straight down the runway, hold a bit of up elevator to keep the tail on the ground to maintain tail wheel steering, then gradually advance the throttle. As the model gains speed decrease up elevator, allowing the tail to come off the ground. One of the most important things to remember with a tail dragger is to always be ready to apply **right** rudder to counteract engine torque. Gain as much speed as your runway and flying site will practically allow before gently applying up elevator, lifting the model into the air. At this moment it is likely that you will need to apply more right rudder to counteract engine torque. Be smooth on the elevator stick, allowing the model to establish a **gentle** climb to a safe altitude before turning into the traffic pattern.

## Flight

For reassurance and to keep an eye on other traffic, it is a good idea to have an assistant on the flight line with you. Tell him to remind you to throttle back once the plane gets to a comfortable altitude. While full throttle is usually desirable for takeoff, most models fly more smoothly at reduced speeds.

Take it easy with the U-CAN-DO-3D for the first few flights, gradually getting acquainted with it as you gain confidence. Adjust the trims to maintain straight and level flight. After flying around for a while and while still at a safe altitude with plenty of fuel, practice slow flight and execute practice landing approaches by reducing the throttle to see how the model handles at slower speeds. Add power to see how she climbs as well. Continue to fly around, executing various maneuvers and making mental notes (or having your assistant write them down) of what trim or C.G. changes may be required to fine tune the model so it flies the way you like. Mind your fuel level, but use this first flight to become familiar with your model before landing.

## Landing

To initiate a landing approach, lower the throttle while on the downwind leg. Allow the nose of the model to pitch downward to gradually bleed off altitude. Continue to lose altitude, but maintain airspeed by keeping the nose down as you turn onto the crosswind leg. Make your final turn toward the runway (into the wind) keeping the nose down to maintain airspeed and control. Level the attitude when the model reaches the runway threshold, modulating the throttle as necessary to maintain your glide path and airspeed. If you are going to overshoot, smoothly advance the throttle (always ready on the right rudder to counteract torque) and climb out to make another attempt. When you're ready to make your landing flare and the model is a foot or so off the deck, smoothly increase up elevator until it gently touches down. Once the model is on the runway and has lost flying speed, hold up elevator to place the tail on the ground, regaining tail wheel control.

One final note about flying your model. Have a goal or flight plan in mind for **every** flight. This can be learning a new maneuver(s), improving a maneuver(s) you already know, or learning how the model behaves in certain conditions (such as on high or low rates). This is not necessarily to improve your skills (*though it is never a bad idea!*), but more importantly so you do not surprise yourself by impulsively attempting a maneuver and suddenly finding that you've run out of time, altitude or airspeed. Every maneuver should be deliberate, not impulsive. For example, if you're going to do a loop, check your altitude, mind the wind direction (anticipating rudder corrections that will be required to maintain heading), remember to throttle back at the top and make certain you are on the desired rates (high/low rates). A flight plan greatly reduces the chances of crashing your model just because of poor planning and impulsive moves. **Remember to think. Have a ball! But always stay in control and fly in a safe manner.**

**GOOD LUCK AND GREAT FLYING!**

## PERFORMANCE SETTINGS FOR THE U-CAN-DO 3D

After testing this plane with several different engines, props, CG locations and countless different control throw settings, I found the following setup to be ideal for **my** particular style of flying 3D.

*Mike Cross, Two Time US National Freestyle IMAC Champion*

### C.G.

4-7/8" back from the LE of the wing. This is the normal recommended CG and is perfect for the aircraft to hover. Going forward or aft creates a small amount of coupling between the rudder and elevators while hovering. This CG is also very responsive but still has a comfortable "feel" in flight.

### Engine

O.S. .91FS pumped (**OSMG0890**), 15x6 APC (**APCQ1506**), Wildcat 15% nitro (**CATP1105**).

The .61FX hovers pretty well but is a little lacking when things get out of shape.

The .91FX (**OSMG0591**) hovers almost as well as the .91FS with the same 15x6 APC prop. It is not quite as steady as the .91FS.

**NOTE:** Flying on the OS 1.20FS caused more tail weight to be needed, made it so the plane would not sit still on the runway and made it difficult to maintain a hover. The hovering was hindered by using such a low throttle setting that the poor throttle resolution made it very difficult to stay in one spot. I do not recommend a 120 4-stroke or larger engine if performance aerobatics are desired.

### Spinner

Spinner 2-1/4" True Turn (**TRUQ1065**) and True Turn lock nut (**TRUQ3063**).

**Note:** A 2-1/4" nylon spinner is included with the U-Can-Do 3D but with the larger engines it requires extensive trimming of the spinner. If you have to trim the spinner, I strongly suggest using an aluminum spinner instead.

### Servos

Elevators: Futaba 9250 digital (**FUTM0220**)  
Ailerons: Futaba 9250 digital  
Rudder: Futaba 9151 digital (**FUTM0211**)  
Throttle: Futaba 9001 (**FUTM0075**)

The large control throws require a servo with great centering. The digital servos are second to none in this department. You can NOT expect this aircraft to give you optimum performance on non-ball-bearing standard servos such as Futaba S148.

### 3D Control Throws

**ELEVATOR:** 3" [75mm] up  
3" [75mm] down

**RUDDER:** 4" [100mm] right  
4" [100mm] left

**AILERONS:** 2-1/8" [55mm] up  
2-1/8" [55mm] down

**FLAPERONS:** 2" [50mm] up  
2" [50mm] down  
(assigned to a switch,  
not mixed to the elevator)

**Expo for 3D rates (no mixing other than expo):**

Elevators: -20%  
Rudder: -20%  
Ailerons: -20%

### Servo Arms

Larger than stock servo arms are highly recommended for getting the 3D throws from the U-Can-Do 3D. Do not move the pushrods in on the control horns to get the increased throw, as doing this intensifies any play in the system.

**Dubro Super Strength Arms set (**DUBM6670**):**

- The longest single sided arm was used on the rudder.
- The mid sized single sided arms were used on the elevators.
- The double-sided arms were made into single sided aileron servo arms.

## OTHER ITEMS AVAILABLE FROM GREAT PLANES

**Stock #** FUTJ85\*\*  
**Tx** 9CAF  
**Rx** R148DF  
**Servos** (4) S3004  
**Tx NiCd** 700mAh  
**Rx NiCd** 600mAh  
**Band** 50, 72  
**Modulation** FM



**Stock #** FUTJ87\*\*  
**Tx** 9CAP  
**Rx** R149DP  
**Servos** (4) S3001  
**Tx NiCd** 700mAh  
**Rx NiCd** 600mAh  
**Band** 50, 72  
**Modulation** PCM

### Futaba® 9C 9-Channel Radio Systems

The 9C radios include such popular Futaba system features as governor mixing (a Futaba exclusive), switch assignability, factory programming for airplanes, helis and sailplanes, Mode 1-4 selection and expandable CAMPac model memory...PLUS 8-character model naming, improved graphics displays, 2 slider switches, a larger LCD — and Futaba's most user-friendly programming ever! The top left button pulls up the home page, basic and expanded menus; the bottom button finalizes settings. Right buttons move the cursor up and down to the values you want...and the dial does the rest. Rotate the dial to find functions; press to select. Your choices appear on the LCD. 700mAh Tx and 600mAh Rx NiCds add value. 1-year warranty.

### Futaba® S9151 Digital Rudder Servo (FUTM0211)

Length: 1.5 in  
 Width: 0.75 in  
 Height: 1.4 in  
 Weight: 1.75 oz  
 Torque: 131.9 oz/in (4.8V)  
 Speed: 0.19 sec @ 60° (4.8V)



The S9151 delivers high-torque rudder operation for precision aerobatic aircraft. Its digitally enhanced microprocessors reduce response time by about half, allowing the servo to reach full power immediately and maintain torque longer. Other features include a coreless motor, dual ball bearings on the output shaft and high-capacity, high-current wire with low resistance. Futaba J connector. 1-year warranty.

### Futaba® S9001 Aircraft Coreless BB Servo (FUTM0075)

Length: 1.59 in  
 Width: 0.78 in  
 Height: 1.42 in  
 Weight: 1.69 oz  
 Torque: 54.2 oz/in (4.8V)  
 Speed: 0.22 sec. @ 60 degrees (4.8V)

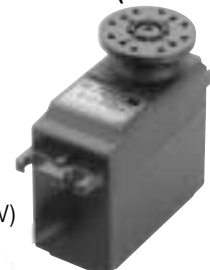

Ideal for airplanes -- as well as sailplanes, helicopters, and nitro- or electric-powered boats -- Futaba's S9001 servo features a coreless motor that reduces weight for smoother, faster response. Dual bearings in the final gear speed transit time. Comes with J connector, one attached servo horn, three extra servo horns and mounting hardware. 1-year warranty.

### O.S. Engines® .91 FX Ringed Engine w/Muffler (OSMG0591)

Displacement: 0.912 cu in (14.95cc)  
 Bore: 1.090 in (27.7mm)  
 Stroke: 0.976 in (24.8mm)  
 Practical RPM: 2,000-16,000  
 Output: 2.8 bhp @ 15,000 rpm  
 Weight: 19.3 oz (550g)

Includes: Muffler, glow plug & safety propeller locknut assembly

Requires: fuel, mount & prop

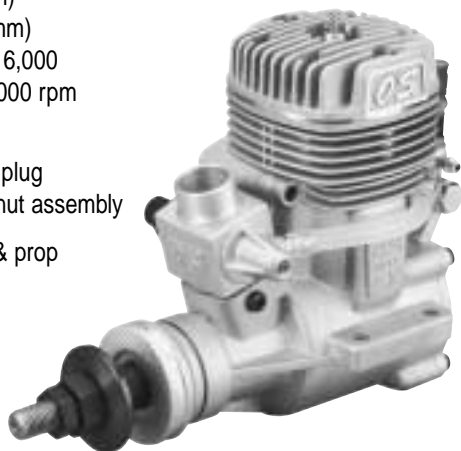

Features dual ball bearings for durability and smooth operation. Its low crankcase profile allows for a taller, semi-squared head with increased cooling fin area. The remote needle valve offers protection and has coarse threads that hold settings securely. Comes with 2-year warranty and muffler with built-in pressure tap.

### O.S. Engines® FS-91 Surpass(tm) II Engine w/Pump (OSMG0890)

Displacement: 0.912 cu in (14.95cc)  
 Bore: 1.09 in (27.7mm)  
 Stroke: 0.976 in (24.8mm)  
 Practical RPM: 2,000-12,000  
 Output: 1.6 bhp @ 11,000 rpm  
 Weight (w/o muffler) : 22.2 oz (678g)  
 Weight (w/muffler): 23.8 oz (630g)

Includes: muffler, manifold & glow plug; PD-07 pump

Requires: glow fuel; prop

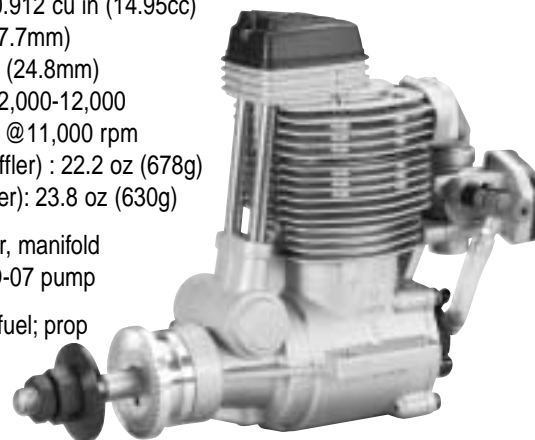

For 4-stroke realism, the pumped FS-91 Surpass II with electronic fuel injection offers optimal flight performance at any attitude. Features include an improved, easy-to-adjust reversible carb; corrosion-resistant plating on the crankshaft, camshaft and piston; a permanently lubricated, rubber-sealed rear bearing for easy maintenance and operation; and muffler that produces a quieter exhaust sound without reducing performance. 2-year warranty.

