



# Sport Fighter Mustang Addendum

The removable canopy is a great asset to the modeler who uses an electric motor installation due to the ease of changing the battery. If you will be flying the Mustang with a glow engine you may find that when you hold the airplane and then use an electric starter to start the engine, the canopy top slips out of position. Because there is no need for the modeler who installs the glow engine to have quick or regular access into the top of the fuselage we recommend that you consider doing the following additional steps. This will firmly secure the canopy to the fuselage and still allow it to be removed later if you should have a need to access the fuel tank.

The steps illustrated should be completed any time after “**COMPLETE THE RADIO INSTALLATION**” on page 18 of the manual.

**Step 1.** With the canopy removed from the airplane, measure forward from the rear of the canopy 3" [76 mm]. Make a mark in the center of the plywood on both sides of the fuselage.

**Step 2.** Drill a 1/16" [1.6 mm] hole on both of the marks.

**Step 3.** Install the canopy to the fuselage. Secure the canopy by installing a 2x6 mm self-tapping washer head screw through the holes you drilled, screwing them into the canopy.

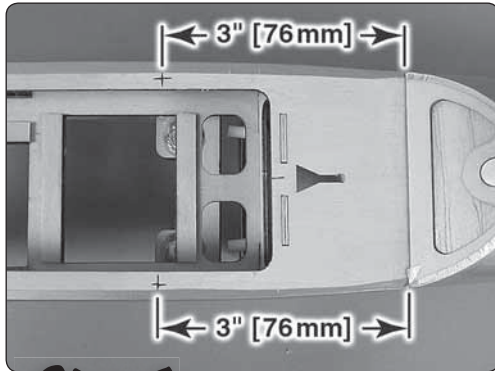

**Step 1**

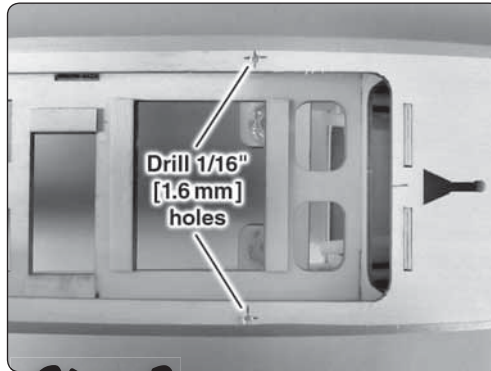

**Step 2**



**Step 3**