

# Dazzler

.40-size Almost-Ready-to-Fly Aerobatic Model

ARF

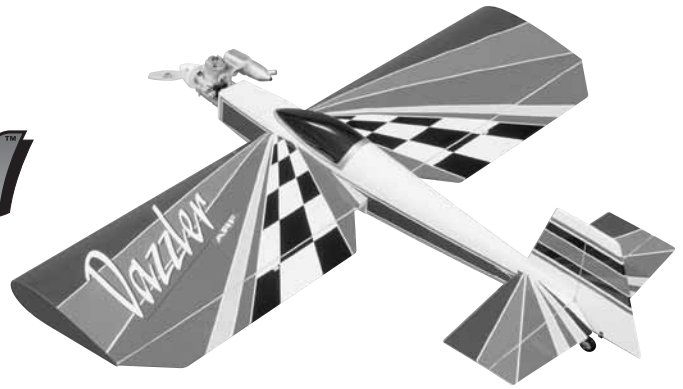

Great Planes has upgraded the Dazzler ARF to a lighter glass filled nylon engine mount.

Please follow these additional instructions to install the engine after completing step 3 on page number 9.

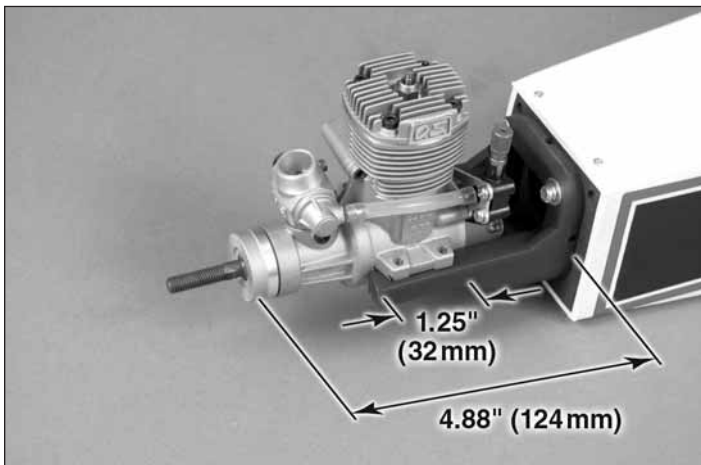

1. Place the engine on the mount so that the propeller washer is 4.88" (124mm) from the firewall and so the mounting flanges on the engine are within 1.25" (32mm) from the ends of the mount.

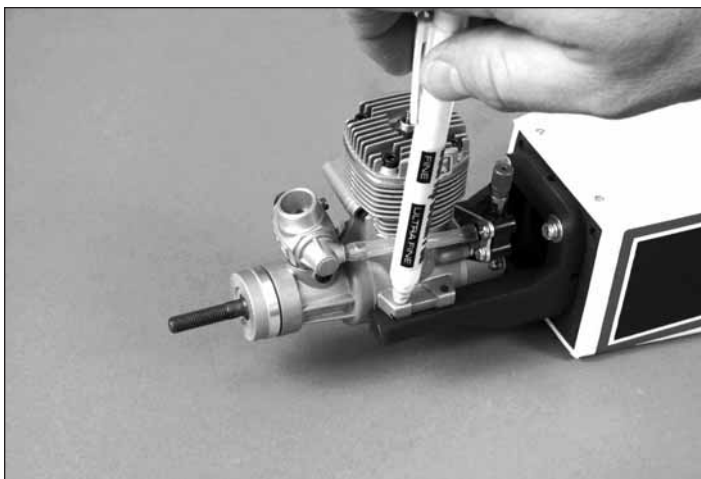

2. Mark the position of the four mounting holes on the engine mount through the engine mounting flanges with a felt tip pen.



3. Remove the engine and drill the four mounting holes with a 9/64" (3.5mm) drill bit.

4. Place the engine back on the mount and resume construction by following step 5 on page 9 of the manual. Be sure to use threadlocker during construction.

 **GREAT PLANES**<sup>®</sup>  
MODEL MANUFACTURING COMPANY