

EXTRA 300S

Aerobatic .40-Size Sport-Scale Kit

INSTRUCTION MANUAL



WARRANTY

Great Planes Model Manufacturing Co. guarantees this kit to be free from defects in both material and workmanship at the date of purchase. This warranty does not cover any component parts damaged by use or modification. **In no case shall Great Planes' liability exceed the original cost of the purchased kit.** Further, Great Planes reserves the right to change or modify this warranty without notice.

In that Great Planes has no control over the final assembly or material used for final assembly, no liability shall be assumed nor accepted for any damage resulting from the use by the user of the final user-assembled product. By the act of using the user-assembled product, the user accepts all resulting liability.

If the buyers are not prepared to accept the liability associated with the use of this product, they are advised to return this kit immediately in new and unused condition to the place of purchase.

READ THROUGH THIS INSTRUCTION MANUAL FIRST. IT CONTAINS IMPORTANT INSTRUCTIONS AND WARNINGS CONCERNING THE ASSEMBLY AND USE OF THIS MODEL.



P.O. Box 788

Urbana, IL 61801 (217) 398-8970

TABLE OF CONTENTS

INTRODUCTION	2
PRECAUTIONS	2
DECISIONS YOU MUST MAKE	3
Engine Selection	3
Exhaust System	3
PREPARATIONS	3
Required Accessories	3
DIE-CUT PATTERNS	4,5
Building Supplies and Tools	6
Optional Supplies and Tools	6
Types of Wood.....	6
Common Abbreviations.....	6
Building Notes.....	7
Get Ready to Build.....	7
BUILD THE TAIL SURFACES.....	7
Make the Stab Leading Edge Doubler	7
Build the Stab.....	7
Recommended Elevator Building Sequence.....	9
Recommended Fin Building Sequence.....	9
Recommended Ruder Building Sequence.....	9
Hinge the Tail Surfaces	9
Finish the Tail Surfaces	10
BUILD THE WING.....	12
Build the Wing Panels	12
Join the Wing Panels.....	15
Sheet the Wing.....	15
Build the Ailerons	17
BUILD THE FUSELAGE.....	20
Assemble the Fuselage Sides.....	20
Mount the Wing to the Fuselage	23
Finish the Bottom of the Fuselage	26
Build the Front Fuselage Deck.....	27
Mount the Stab and Fin to the Fuselage.....	28
Build the Turtle Deck	29
Mount the Engine.....	31
Install the Servos and Make the Pushrods.....	31
Assemble the Wheel Pants	34
Assemble the Cowl	35
PREPARE THE MODEL FOR COVERING	37
COVER ING	38
Covering Technique.....	38
Suggested Covering Sequence	38
PAINTING	39
FINAL HOOK-UPS AND CHECKS	39
Join the Control Surfaces.....	39
Install the Hardware	40
Attach the Canopy.....	41
Set the Control Throws.....	41
Balance Your Model.....	42
PREFLIGHT.....	42
Charge the Batteries	42
Balance the Propeller.....	43
Find a Safe Place to Fly	43
Ground Check the Model	43
Range Check the Radio.....	43
Engine Safety Precautions.....	43

AMA Safety Code	44
General	44
Radio Control	44
FLYING	44
Takeoff.....	44
Flight	45
Landing	45
APPENDIX.....	45
TRIM CHART.....	45
TWO VIEW DRAWING.....	BACK COVER

PROTECT YOUR MODEL, YOURSELF & OTHERS...FOLLOW THIS IMPORTANT SAFETY PRECAUTION

Your Extra 300 is not a toy, but rather a sophisticated, working model that functions very much like an actual airplane. Because of its realistic performance, the Extra, if not assembled and operated correctly, could possibly cause injury to yourself or spectators and damage property.

If this is your first low wing sport model we recommend that you get help from an experienced, knowledgeable modeler with your first flights. You'll learn faster and avoid risking your model before you're truly ready to solo. Your local hobby shop has information about flying clubs in your area whose membership includes qualified instructors.

You may also contact the national Academy of Model Aeronautics (AMA), which has more than 2,300 chartered clubs across the country.



Academy of Model Aeronautics

5151 East Memorial Drive
Muncie, IN 47302-9252
Tele. (800) 435-9262
Fax (317) 741-0057

INTRODUCTION

Congratulations and thank you for purchasing the Great Planes Extra 300. For the record, the model we have chosen to replicate is the Extra 300S.

The Extra is a rather "square" airplane with well defined lines. Coincidentally, this makes it exceptionally easy to build and cover—especially for a semi-scale sport model. Framing the model is very straightforward as most of the structure features interlocking balsa and lite-ply. The Turtle deck sheeting may look a little intimidating but in actuality it is quite easy to apply if you follow the instructions and use the template provided to cut the sheeting.

Flying the Extra 300 is a thrilling experience—as it should be for such an aerobatic model! It doesn't take much elevator

or aileron throw to put the Extra through its paces. Of course, the throws can be decreased to low rates (illustrated in the instructions) if you'd just like to take it easy and poke holes in the sky. The Extra performs surprisingly well on a ball bearing schnurle ported .40 2-stroke but seasoned experts will surely want to get the most out of the Extra by strapping on a .46 2-stroke or a .70 4-stroke.

We hope you enjoy building and flying your Great Planes Extra 300S as much as we did the prototypes.

Please inspect all parts carefully before starting to build! If any parts are missing, broken or defective, or if you have any questions about building or flying this airplane, please call us at (217) 398-8970. If you are calling for replacement parts, please reference the part numbers and the kit identification number (stamped on the end of the carton) and have them ready when calling.

PRECAUTIONS

1. Build the plane according to the plans and instructions. Do not alter or modify the model, as doing so may result in an unsafe or unflyable model. In a few cases the plans and instructions may differ slightly from the photos. In those instances the plans and written instructions are correct.
2. Take time to build straight, true and strong.
3. Use an R/C radio system that is in first-class condition, and a correctly-sized engine and components (fuel tank, wheels, etc.) throughout your building process.
4. You must properly install all components so that the model operates properly on the ground and in the air.
5. You must check the operation of the model before **every** flight to ensure that all equipment is operating, and that the model has remained structurally sound. Be sure to check nylon clevises or other connectors often and replace them if they show signs of wear or fatigue.
6. If you are not already an experienced R/C pilot you must fly the model only with the help of a competent, well experienced R/C pilot.

NOTE: We, as the kit manufacturer, provide you with a top quality kit and great instructions, but ultimately the quality of your finished model depends on how **you** build it; therefore, we cannot in any way guarantee the performance of your completed model, and no representations are expressed or implied as to the performance or safety of your completed model.

Remember: Take your time and follow directions to end up with a well-built model that is straight and true.

DECISIONS YOU MUST MAKE

Engine Selection

There are several engines that will work well in your Extra 300, but for unlimited performance we recommend a *hot* 2-stroke such as an O.S.® .46FX or SuperTigre™ G45. If you prefer a 4-stroke, an O.S. .70 Surpass is the ticket. Your choice of 2-stroke or 4-stroke will determine the location of the throttle servo and throttle pushrod exit on the firewall so plan ahead.

Exhaust System

If you choose to use a 2-stroke engine we suggest an in-cowl muffler for the best appearance. On our prototype Extra 300 with the O.S. .46SF we used the Slimline #3218 Pitts Muffler (SLIG2218) without the exhaust extension kit. If you prefer to use the exhaust extension kit purchase #8012 (SLIG5012).

PREPARATIONS

Required Accessories

Items in parenthesis (OSMG2691) are suggested part numbers recognized by distributors and hobby shops and are listed for your ordering convenience. GPM is the Great Planes brand, TOP is the Top Flite brand, and HCA is the Hobbico brand.

- 4 Channel Radio with 4 Servos
- Engine - See **Engine Selection** above
- Muffler - See **Exhaust System** above
- Spare Glow Plugs (O.S. #8 for most 2-stroke engines, OSMG2691)
- Propeller (Top Flite® Power Point™); Refer to your engine's instructions for proper size
- Top Flite MonoKote® covering (Approximately 2 rolls)
- Fuelproof paint - See **Painting** (page 39)
- Medium Fuel Tubing (GPMQ4131)
- 1/4" Latex Foam Rubber Padding (HCAQ1000)
- 1/16" Foam Wing Seating Tape (GPMQ4422)
- 10 oz. Fuel Tank (GPMQ4104)
- (2) 2-1/2" Wheels (GPMQ4223)
- (1) 3/32" Wheel Collar (GPMQ4302)
- 2-1/4" Spinner (GPMQ4517 – red)
- Pilot (Williams Bros. 1/5 Scale Sportsman Pilot used in prototype, WBRQ2485)
- Fueling System (Top Fueler, GPMQ4160)
- (1) 1" Tail wheel (GPMQ4241)

DIE-CUT PATTERNS

EXT4F01

2 REQ.

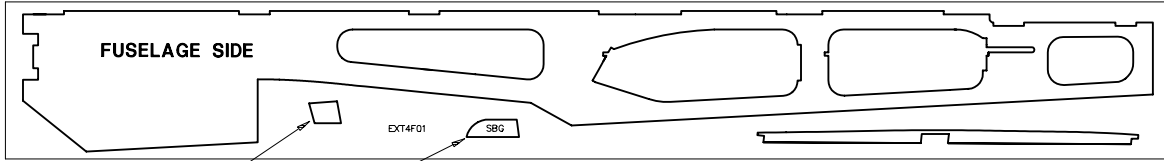

FUSELAGE SIDE
WHEEL PANT REINFORCEMENT
STAB GAUGE
EXT4F01
SBC
1/8" X 5-1/8" X 38" PLY

EXT4F02

1 REQ.

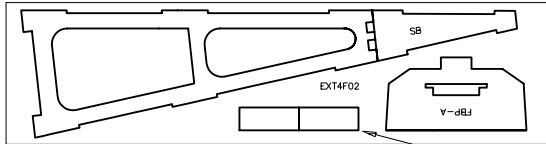

1/8" X 5-3/4" X 17-3/4" PLY
TANK HATCH DOUBLERS

EXT4F04

1 REQ.

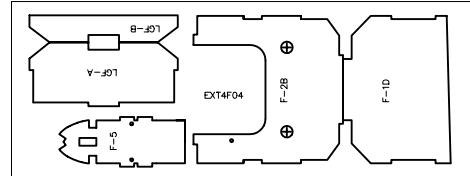

1/8" X 5-3/4" X 15" PLY

EXT4F0F3

1 REQ.

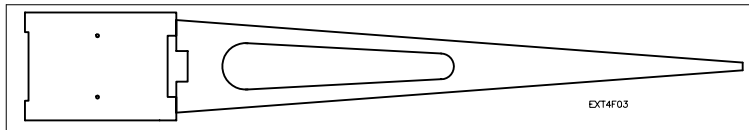

1/8" X 4-1/8" X 24-1/2" PLY

EXT4F05

1 REQ.

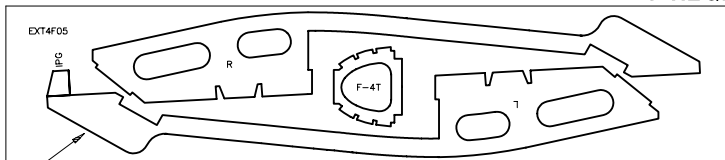

FUSELAGE DOUBLERS
1/8" X 5-1/8" X 23-3/4" PLY

EXT4F08

1 REQ.

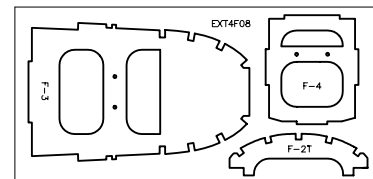

1/8" X 5-3/4" X 11-3/4" PLY

EXT4F06

1 REQ.

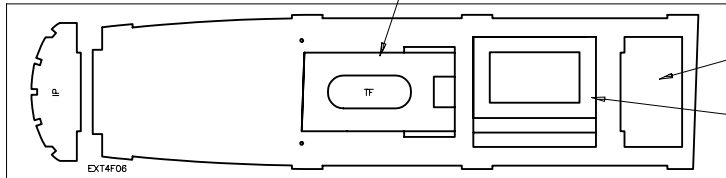

1/8" X 5-3/4" X 23-3/4" PLY

TANK FLOOR

TANK HATCH

SERVO TRAY

EXT4F07

1 REQ.

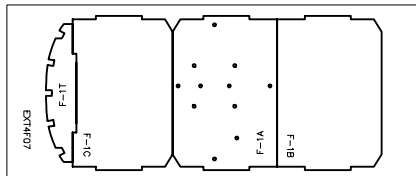

1/8" X 5-3/4" X 13-1/2" PLY

LANDING GEAR PLATES

EXT4F09

1 REQ.

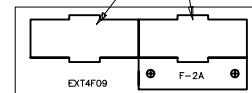

1/8" X 3" X 8" BIRCH PLY

DIE-CUT PATTERNS

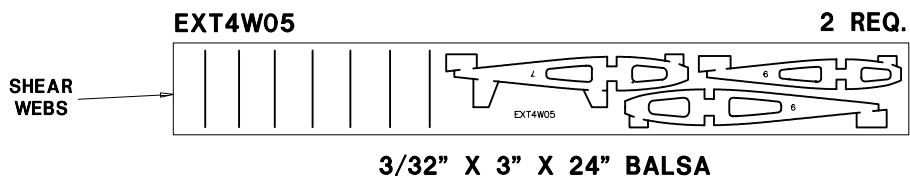
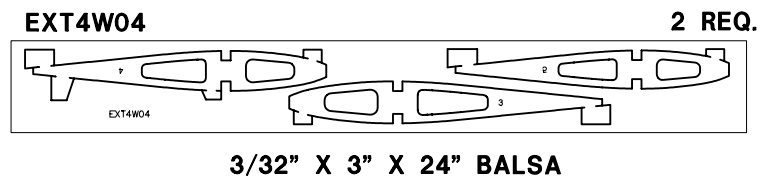
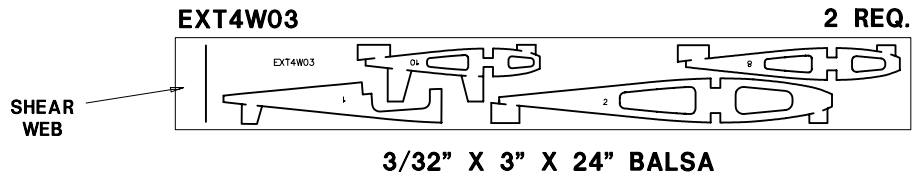
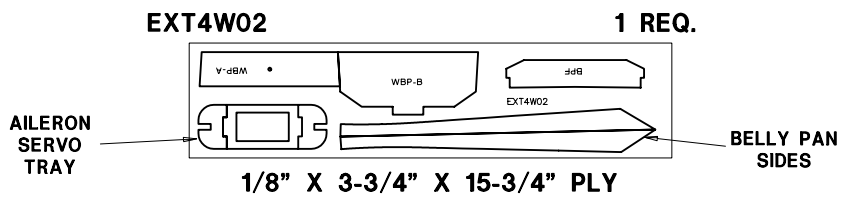
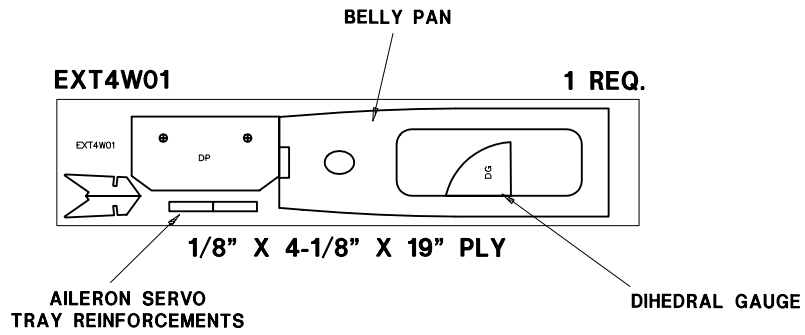

Building Supplies and Tools

These are the building tools, glue, etc. that we recommend and mention in the manual. *We recommended Great Planes Pro™ CA and Epoxy*

- 2 oz. Thin CA (GPMR6003)
- 2 oz. Medium CA+ (GPMR6009)
- CA Accelerator (GPMR6035)
- 30-Minute Pro Epoxy (GPMR6047)
- Pacer Formula 560 Canopy Glue
- #1 Hobby Knife Handle (XACR4305)
- #11 Blades (HCAR0311, 100 qty.)
- Razor Saw
- X-Acto® (or similar) Building Square (XACR7726) or Building Triangle (XACR7725)
- Small T-pins (HCAR5100)
- Medium T-pins (HCAR5150)
- Waxed Paper
- Masking Tape
- Electric Power Drill
- 1/4-20 Tap (GPMR8105, drill bit included)
- Drill Bits: 1/16", 3/32", 7/64", 1/8", 5/32", #18 or 11/64", 3/16", #10 or 13/64" (unless purchased with 1/4-20 Tap listed above), 7/32", 1/4"
- Pliers
- Monofilament String for aligning wing and stabilizer
- Screwdrivers (Phillips and Flat Blade)
- HobbyLite Balsa Filler (HCAR3401)
- Sealing Iron (TOPR2100)
- Bar Sander or Sanding Block and Sandpaper (coarse, medium, fine grit)*



In our busy work shop we use the Great Planes **Easy-Touch Bar Sanders** equipped with Great Planes #80, #150 and #220-grit **Easy-Touch Adhesive-Backed Sandpaper**. Great Planes **Easy-Touch Bar Sanders** are made from lightweight, rigid, extruded aluminum and can be found at most hobby shops.



They are available in three sizes—5-1/2" (GPMR6169) and 11" (GPMR6170) for most general purpose sanding and 22" (GPMR6172) for long surfaces such as wing leading edges. The **Easy-Touch Adhesive-Backed Sandpaper** comes in 2" x 12' rolls of 80-grit (GPMR6180), 150-grit (GPMR6183), 220-grit (GPMR6185) and an assortment

pack of 5-1/2" long strips (GPMR6189) for the short Bar Sander. The adhesive backed sandpaper is easy to apply and remove from your sanding bar when it's time for replacement.

This setup is all that is required for almost any sanding task. Custom sanders can be made from balsa or hardwood blocks and sticks for sanding difficult to reach spots. We also keep some #320-grit wet-or-dry sandpaper for finish sanding just before covering.

Optional Supplies and Tools

- 1 oz. Thick CA- (GPMR6014)
- 6-Minute Pro Epoxy (GPMR6045)
- CA Applicator Tips (HCAR3780)
- Epoxy Brushes (GPMR8060)
- Epoxy Mixing Sticks (GPMR8055, qty. 50)
- CA Debonder (GPMR6039)
- Hot Sock (TOPR2175)
- Trim Seal Tool (TOPR2200)
- Heat Gun (TOPR2000)
- Single Edge Razor Blades (HCAR0312, 100 qty.)
- Razor Plane (MASR1510)
- Straightedge (Fourmost Non Slip, FORR2149)
- 1/8" Brass Tube, see page 11, step 7
- 5/32" Brass Tube, see page 33, step 18
- Denatured or Isopropyl Alcohol (for epoxy clean-up)
- Dremel MultiPro™ or similar w/Sanding Drum, Cutting Burr, Cut-off Wheel
- Kyosho Curved Scissors for trimming Cowl, Wheel Pants, and Canopy (KYOR1010)

Types of Wood

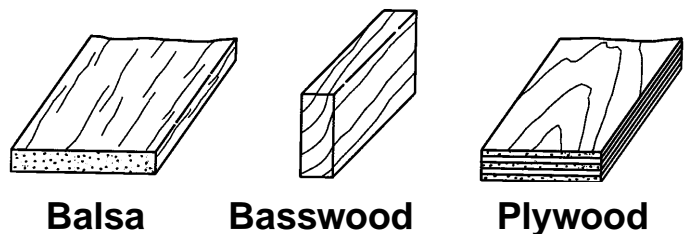

Balsa

Basswood

Plywood

Common Abbreviations

Elev = Elevator
LE = Leading Edge (front)
Lt = Left
Rt = Right
TE = Trailing Edge (rear)

Fuse = Fuselage
LG = Landing Gear
Ply = Plywood
Stab = Stabilizer
" = Inches

Building Notes

There are two types of screws used in this kit:

Sheet metal screws are designated by a number and a length.

For example #6 x 3/4"

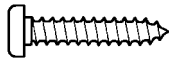

Machine screws are designated by a number, threads per inch and a length.

For example 4-40 x 3/4"



When you see the term "**test fit**" in the instructions, it means you should first position the part on the assembly **without using any glue**, then slightly modify the part as necessary for the best fit.

Whenever just "**epoxy**" is specified you may use **either** 30-minute epoxy **or** 6-minute epoxy. When 30-minute epoxy is **specified** it is **highly recommended** that you use only 30-minute (or slower) epoxy because you will need either the working time and/or the additional strength.

Several times during construction we refer to the "top" or "bottom" of the model or a part of the model. For example, during wing construction we tell you to "glue the top main spar" or "trim the bottom of the former." It is understood that the "top" or "bottom" of the model is as it would be when the airplane is right side up and will be referred to as the "top" even if the model is being worked on upside down. I.E. the "top" main spar is always the "top" main spar even when the wing is being built upside down.

Get Ready to Build

1. Unroll the plan sheets. Reroll the plans inside out to make them lie flat.

2. Remove all parts from the box. As you do, figure out the name of each part by comparing it with the plans and the parts list included with this kit. Using a felt-tip or ballpoint pen, lightly write the part **name** or **size** on each piece to avoid confusion later. Use the die-cut patterns shown on pages 4 and 5 to identify the die-cut parts and mark them **before** removing them from the sheet. **Save all scraps**. If any of the die-cut parts are difficult to punch out, do not force them! Instead, cut around the parts with a hobby knife. After punching out the die-cut parts, use your bar sander or sanding block to **lightly** sand the edges to remove any die-cutting irregularities or slivers.

3. As you identify and mark the parts, separate them into groups, such as **fuse** (fuselage), **wing**, **fin**, **stab** (stabilizer) and **hardware**.

BUILD THE TAIL SURFACES

Make the Stab Leading Edge Doubler

You may remove the stabilizer and elevator drawing from the wing plan by cutting along the dotted line. Don't forget to cover the plans with waxed paper so the glue won't stick to them.

1. Begin making the **stab leading edge doubler** by *accurately* cutting the 1/4" x 1-1/2" x 15" balsa sheet so it is 13-3/4" long.

2. Use a ballpoint pen and a drafting square to *accurately* mark the centerline of the stab doubler (6-7/8" from the end). Use your pen to mark another line on both ends of the doubler 7/8" from one edge. The following photo shows the locations of these marks.

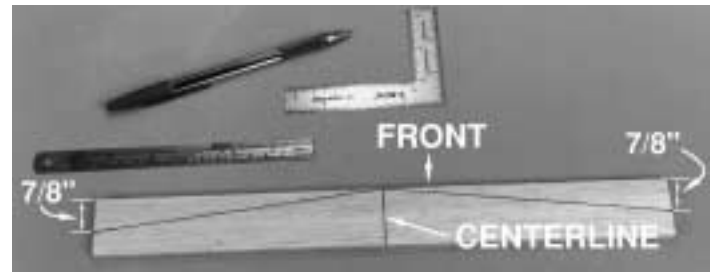

3. Use a straightedge to draw a line connecting the centerline of the stab doubler with the marks on the ends as shown in the photo.

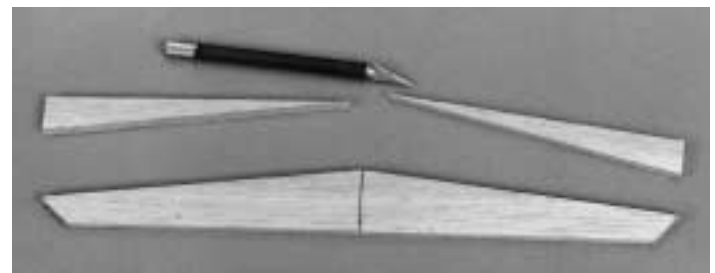

4. Use a hobby knife with a sharp #11 blade to cut along the lines you drew. If necessary, use a bar sander to true the leading edges you just cut. Use the plan as a guide to mark and cut the bevel on both ends of the stab doubler.

Build the Stab

1. Pin the stab LE doubler in position over the plan. Cut the **stab center** from the 1/4" x 2" x 6" balsa sheet and save the small piece you cut off. Add a bead of medium CA to the front of the stab center, then glue it to the LE doubler and pin it in position. Wipe away excess CA before it cures.

Note: Refrain from using excessive accelerator. Even hours after it's sprayed on, residual accelerator can prematurely and unexpectedly cure the CA you use later on nearby glue joints. Unless you must handle or remove the part from your building board right away, we recommend using no accelerator at all.

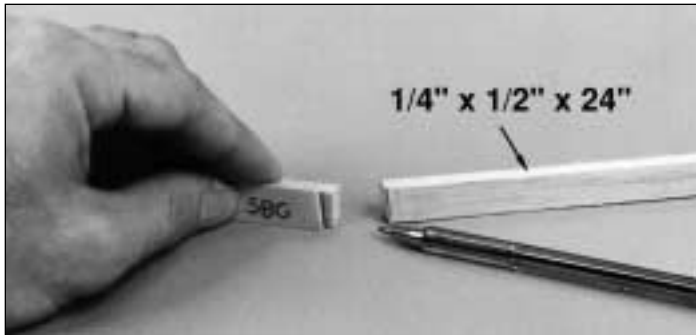

❑ 2. Cut a 1/4" x 1/2" x 24" balsa stick (**do not use the 30" long stick**—it's for the fuse turtle deck) into two 12" long pieces to make the **stab leading edges**. Use the die-cut 1/8" plywood **stab bevel gauge (SBG)** to mark, then cut one end of both sticks. Don't cut the **tips** of the LE's yet. Cut and "square them up" with the end of the stab **after** you remove it from the plan at step 7. Glue the stab LE's to the LE doubler with medium CA and pin them in position over the plan.

❑ 3. Glue a 1/4" x 1/2" x 24" balsa stick to the stab center and pin it in position over the plan for the **stab trailing edge**. Use the plans or a straightedge as a guide to make sure the stab trailing edge is **straight** as you pin it in position.

Hint: If possible, choose one of the softer pieces of wood for the stab trailing edge. This will make cutting the hinge slots easier than if you were to use a harder piece of wood.

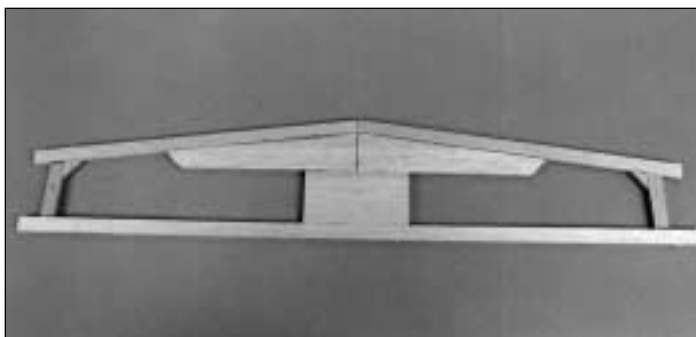

❑ 4. Cut the ends of the stab from another 1/4" x 1/2" x 24" balsa stick using the stab bevel gauge to cut them at the correct angle. Glue the ends of the stab to the leading and trailing edges and pin them in position. Make the **gussets** from the 1/4" x 1/2" stick and glue them in position (you can use the stab bevel gauge to make the gussets too).

❑ 5. Make the **1/4" tail ribs** from a 1/4" x 1/4" x 24" balsa stick, then glue them in position. You can use the stab bevel gauge for two of the ribs and the 2" wide piece you cut off the stab center as a gauge to cut the remaining four 1/4" ribs to exact length.

Hint: Use a sharp single edge razor blade to cut the tail ribs.

❑ 6. Make the **1/8" tail ribs** from a 1/8" x 1/4" x 24" balsa stick, then glue them in position. We recommend cutting these tail ribs with a single edge razor blade too. *Sorry, no gauges for these. You'll just have to rely on pure skill!*



❑ 7. Remove the stab from your building board. Inspect all the glue joints and add CA to any joints that don't look strong. Cut the ends of the leading and trailing edges so they extend past the end of the stab by about 1/16". Use your bar sander to finish the job by sanding the ends of the LE's and TE so they are flush with the end of the stab. Cut the 1/8" x 1/4" tips, then glue them to the end of the stab.

❑ 8. Use your bar sander or a large sanding block and 220-grit sandpaper to sand the entire top and bottom surface of the stab until it is flat and even. **Be careful** while sanding so you do not over-thin any one particular area of the stab or gouge the stab ribs by snagging the sandpaper on them.

There, that was kind of fun wasn't it? Let's continue to build the elevators, fin and rudder.

❑ 9. Follow the recommended building sequence that follows to build the elevators, fin and rudder from the same sizes of balsa sticks you used for the stab. Use the die-cut 1/8" plywood **elevator bevel gauge (EBG)** where appropriate. The **elevator root ends** are made from the leftover piece you cut from the 1/4" x 2" x 6" balsa sheet at step 1.

Hint: Cut one of the elevator root ends from the plan and use it as a template to make the balsa part. The **rudder balance tab**, **rudder bottom** and **fin base** are made from the 1/4" x 2" x 10" balsa sheet.

Recommended Elevator Building Sequence

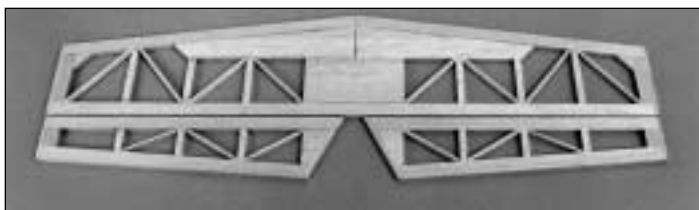

- A. LE (leave 1/16" long at both ends)
- B. Root end
- C. TE (cut 1/16" long at both ends)
- D. 1/4" x 1/2" tip
- E. 1/4" ribs
- F. 1/8" diagonal ribs
- G. Remove the elevator from the plan and inspect all the glue joints. Add CA where necessary. Sand the LE and TE flush with ends
- H. Add 1/8" tips, sand flat and smooth with bar sander and 220-grit sandpaper.
- I. Build the other elevator the same as the first.

Recommended Fin Building Sequence

- A. LE (cut 1/16" long at both ends)
- B. Fin tip (use 1/4" x 3/4" x 24" balsa stick, remainder is saved for front fuse deck sides)
- C. Fin base
- D. TE (cut 1/16" long at both ends)
- E. 1/8" tail ribs
- F. Remove the fin from your building board and inspect all the glue joints. Add CA where necessary. Use your bar sander to sand the top of the leading and trailing edges even with the tip of the fin. Sand the bottom of the leading edge even with the base. Sand the entire fin flat and smooth with your bar sander and 220-grit sandpaper.

Recommended Rudder Building Sequence



- A. LE (cut 1/16" long at both ends)
- B. Rudder tip

- C. Rudder bottom
- D. TE
- E. 1/8" tail ribs (glue the two "straight" ribs before the diagonal ribs)
- G. Inspect all the glue joints and add CA where necessary. Shape the bottom of the rudder as shown on the plan. Sand the entire rudder flat and smooth with your bar sander.

Note: The Balance Tab will be made later.

Hinge the Tail Surfaces

1. Place the stab over its location on the plan and *lightly* mark the **hinge locations** on the trailing edge with a ballpoint pen. Mark the hinge locations on the elevators in the same manner.
2. See the Expert Tip that follows, then mark the locations of the **hinge slots** on the stab and elevators.



HOW TO MARK THE HINGE SLOTS

It's important that the hinge slots are **centered** and **parallel** to the part you are hinging. The best way to start is by accurately marking the hinge slots. We'll start with the stabilizer.

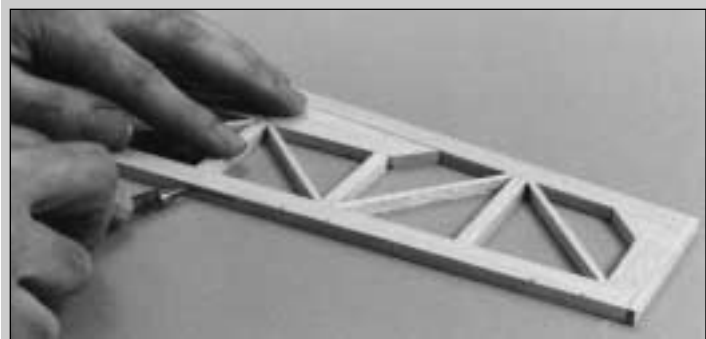

- A. Lay the stabilizer and a ballpoint pen on a flat surface. Mark a "test line" on the trailing edge of the stab away from the hinge locations you marked earlier.

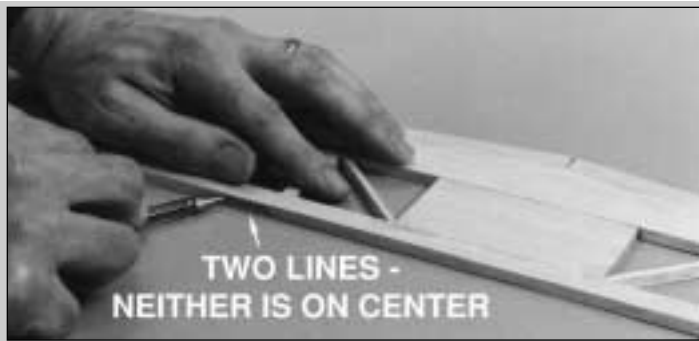

B. Flip the stab over and mark another line in the same location as the first. If you see only one line, then it is on center. Proceed and mark the hinge slots at each hinge location. If you see two lines (as in the photo) you will have to adjust the height of the stab until you can mark the centerline.



C. Use playing cards or business cards to adjust the height of the stabilizer until you can mark the centerline. Mark the hinge slots at each hinge location.

D. Use the same technique to mark the centerline along the **entire length** of both elevators.

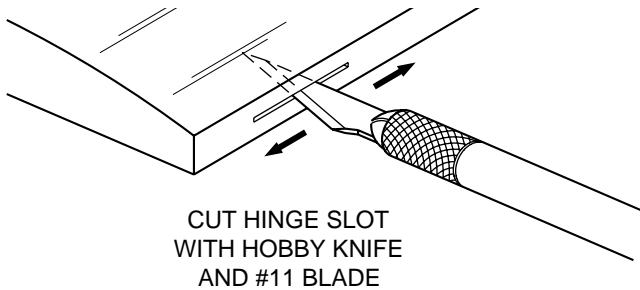
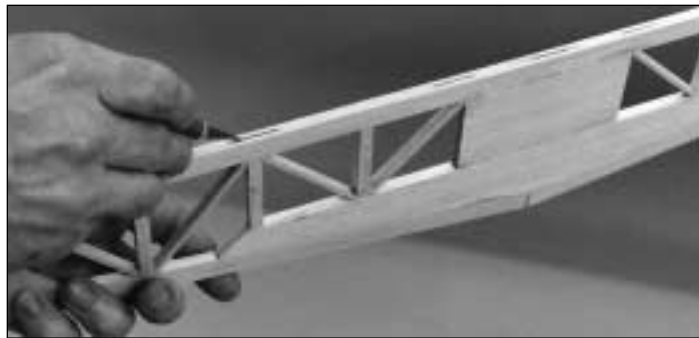

3. Cut the hinge slots in the elevator and stabilizer using a #11 blade. Begin by **carefully** cutting a very shallow slit at the hinge location to accurately establish the hinge slot.

Make three or four more cuts going a little deeper each time. As you cut, slide the knife from side to side until the slot has reached the proper depth and width for the hinge.

4. Cut the hinges for the elevators and rudder from the supplied 2" x 9" **hinge material**, then snip off the corners. **Temporarily** join the elevators to the stab with the hinges adjusting any hinge slots if necessary so they all align. **Do not glue in the hinges until you are instructed to do so.**

5. Return to step 1 and use the same procedures to hinge the rudder and fin.

Finish the Tail Surfaces

1. Refer to the **Expert Tip** that follows and shape the leading edge of the elevators to a "V" as shown on the plans.



HOW TO BEVEL THE LEADING EDGES

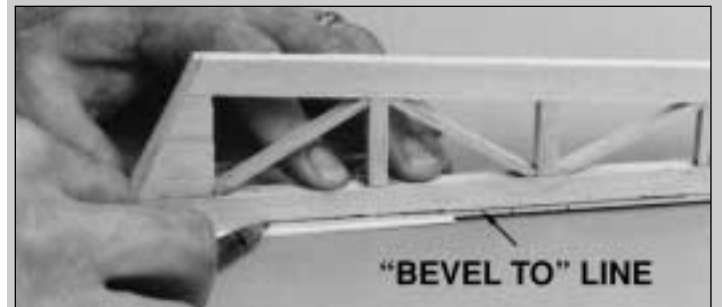

A. Place the leading edge of one of the elevators on your work surface and use your ballpoint pen to mark a "bevel to" line on both sides about 3/32" high.

Note: You will probably have to adjust the height of the elevator with card stock (as you did while marking the hinge slots) so your "bevel to" line is not too high – making too sharp of a "V."



B. Using the bevel to lines and the center line as a guide, make the "V" on the leading edge of the elevators with a razor plane or your bar sander with 150-grit sandpaper.

- ❑ 2. Use the same procedure to bevel the leading edge of the rudder.

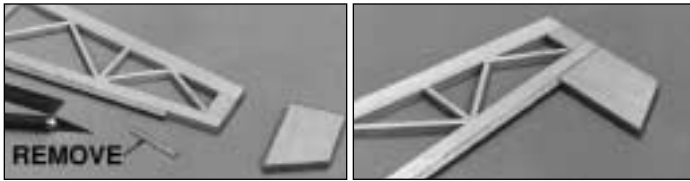

- ❑ 3. Cut a notch in the leading edge of the rudder for the balance tab. The notch should be the same height as the balance tab (1-3/8") and approximately 1/8" deep or, as deep as the "V" on the leading edge. Make the balance tab from the remaining piece of balsa left over from the 1/4" x 2" x 10" sheet. Glue the balance tab to the rudder with medium CA, then glue the 1/8" balsa tip to the top of the rudder.

Let's get back to the elevators.

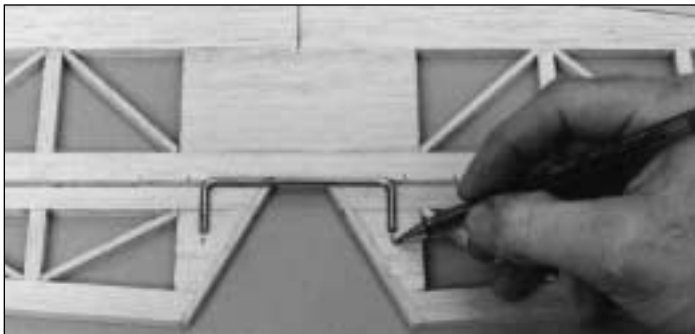

- ❑ 4. Make sure the tips of the elevators are even with the tips of the stab, then lay the **elevator joiner wire** on top of the elevators in the position shown on the plan. Use your ballpoint pen to lightly mark the centerline of the ends of the joiner wire on the stab.

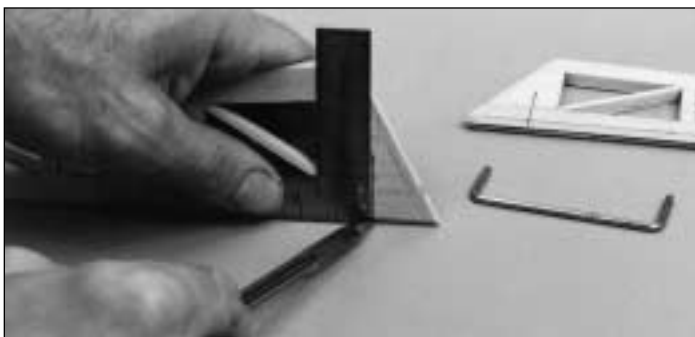

- ❑ 5. Remove the elevators from the stab and use a draftsman's square to extend the line you marked on both elevators to the leading edge.



- ❑ 6. Drill a 3/32" pilot hole into the leading edge of the elevators. As you drill each hole keep the drill aligned with the top and bottom surface of the elevator and the reference line you made in the previous step. Redrill the holes with a 1/8" drill bit.

- ❑ 7. Refer to the Expert Tip that follows, then cut a 1/8" groove in the leading edge of both elevators to recess the joiner wire.



HOW TO CUT A GROOVE FOR THE ELEVATOR JOINER WIRE



- A. Use a #11 knife blade to sharpen the end of a piece of 1/8" brass tube. Roll the tube as you *carve* the end. If you have a file or a cut-off wheel it helps to sharpen the outside of the end of the tube as well.



- B. Use the sharpened tube to *carefully* gouge the leading edge of the elevators. You'll have to make a few cuts to make the recess deep enough for the joiner wire.



❑ 8. Temporarily join the elevators with the joiner wire. The joiner wire will be easier to install if you chamfer (bevel) the ends a little. If necessary, “tweak” the joiner wire so the elevators are parallel and lay flat on your building table when the joiner wire is installed. If you found it necessary to “tweak” the joiner wire use a felt-tip pen to mark it so you can install the joiner wire in the same orientation when you permanently join the elevators.

❑ 9. Use your bar sander and 150-grit sandpaper to round the tail surfaces as shown on the fuse plan. Keep the **ends** of the tail surfaces squared off just like the full size Extra 300.

That's about it for the tail surfaces. They're a little more work than sheet surfaces but they are much lighter, just about as strong and add a nice piece of craftsmanship. Clean off your work bench and get out the wing plan!

BUILD THE WING

Build the Wing Panels

Start by building the right wing panel **upside down** over the left wing panel plan so your progress matches the photos.

Note: Due to the decreasing thickness in the wing towards the tip, the top *main spar* is not pinned directly to the building board. Instead, the *ribs* are securely pinned to the building board. This is done so the ribs of both wing halves will be vertical. You must follow the instructions closely on where to insert the T-pins in the ribs so you do not conceal them under the sheeting therefore making it difficult to remove the wing from the building board.

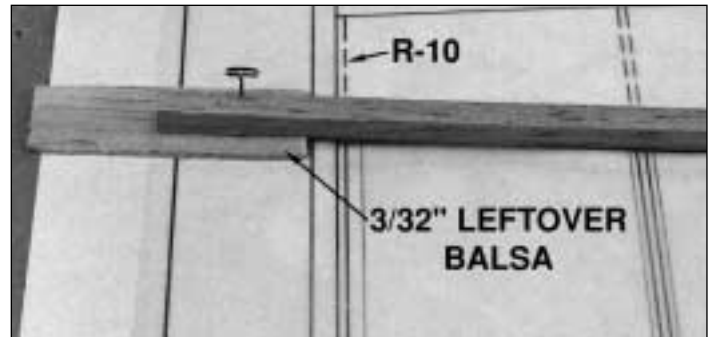
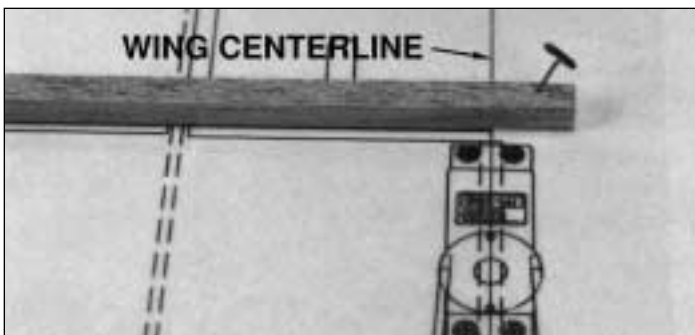

❑ ❶ 1. Use one T-pin to pin the root end of a 5/16" x 5/16" x 30" balsa **main spar** over its location on the plan so approximately 1/2" extends past the wing centerline. This is the **top spar**. Place a piece of 3/32" leftover balsa under the tip of the spar past the location of rib R-10, then pin the tip of the spar to the plan. Insert the T-pin at an angle so it does not interfere with the bottom spar when it is added to the assembly at step 5.

❑ ❷ 2. Place the die-cut 3/32" balsa **wing ribs R-2** through **R-10** on the top spar over their locations on the plan.

Note: The **short** jig tabs, the ones on every rib, should be contacting the plan.

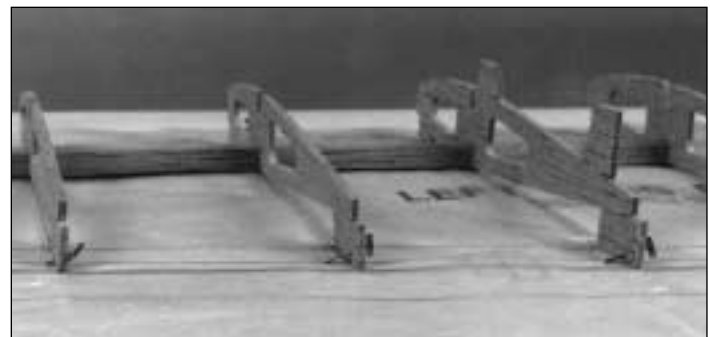

❑ ❸ 3. Using **small** T-pins, pin the **aft jig tab** of ribs R-2 through R-10 to your building board over their location on the plan.

Note: Insert the T-pins at an angle from the rear so they can be removed after the trailing edge and bottom sheeting are glued in position.

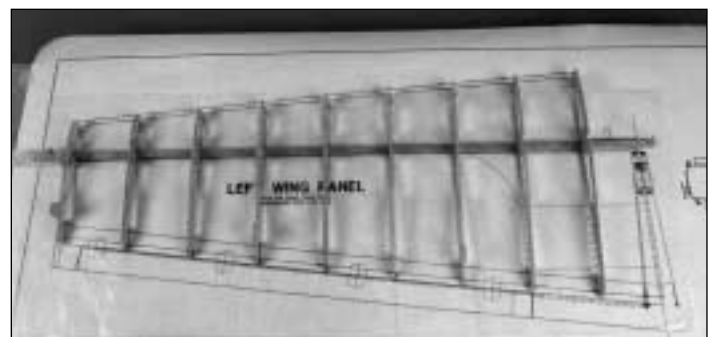

❑ ❹ 4. Use **small** T-pins to pin the **front jig tabs** of ribs R-2 through R-10 to the building board. You may insert the pins into the front jig tabs any way you like because they will be removed **before** the bottom leading sheeting is added.

□ □ 5. Place a 5/16" x 5/16" x 30" **bottom spar** in the notches of the ribs. Approximately 1/2" of the bottom spar should extend past the wing centerline.



□ □ 6. Glue the main spars to the ribs with thin CA. As you glue each rib to the spars, simultaneously *pull* the top spar up into the rib and *push* the bottom spar down into the rib to make sure the spars are fully seated in the notches. Make sure all the jig tabs are contacting the work surface.

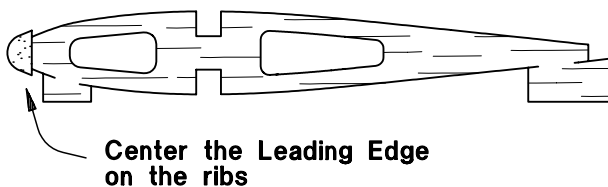

□ □ 7. Position the 27" shaped balsa **leading edge (LE)** on the front of the ribs. The LE should be centered on all the ribs and the root end should extend past rib R-2 by about 1/16". Make sure all the jig tabs are contacting the work surface, then use thin CA to glue the LE to the front of the ribs.

□ □ 8. Use thin CA to glue the shaped 30" balsa **trailing edge (TE)** to the ends of the ribs so approximately 1/2" extends past the centerline of the wing.

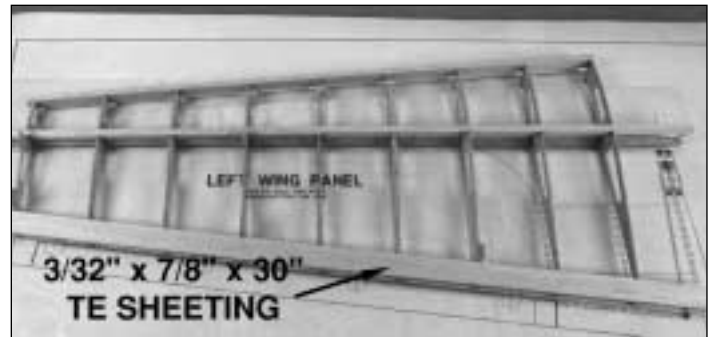

□ □ 9. Use medium CA to glue the 3/32" x 7/8" x 30" balsa **trailing edge sheeting** to the TE and wing ribs so the end extends past the wing centerline by approximately 1/2".



□ □ 10. Starting at ribs R-8 & R-7 test fit, then glue the die-cut 3/32" cross grain balsa **shear webs** to the front of the spars. Note that the shear webs increase in height as they get closer to the root and there are two shear webs that are the same height between ribs 2 & 3 and 3 & 4.

□ □ 11. See the Expert Tip that follows, then glue two 3/32" x 3" x 30" balsa sheets together to make one 6" wide sheet for the top and bottom **leading edge wing sheeting**.

EXPERT TIP

HOW TO MAKE WING SHEETS

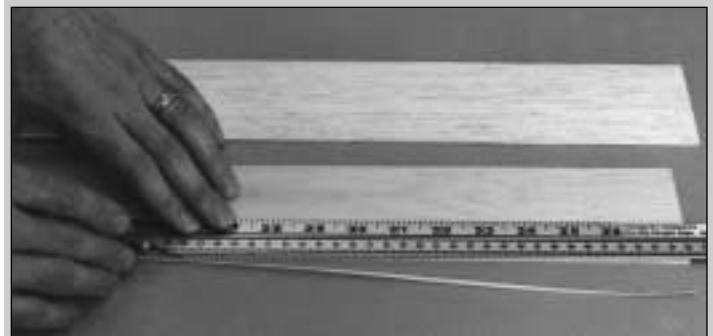

A. Use a metal straightedge as a guide to trim one edge of both sheets.



B. Use masking tape to tightly tape the two sheets together joining the trimmed edges.



C. Turn the sheet over and place weights on top of the sheet to hold it flat. Apply thin CA sparingly to the seam between the two pieces quickly wiping away excess CA with a paper towel as you proceed.

D. Turn the sheet over and remove the masking tape, then apply thin CA to the seam the same way you did for the other side.

E. Sand the sheet flat and smooth with your bar sander and 150-grit sandpaper.

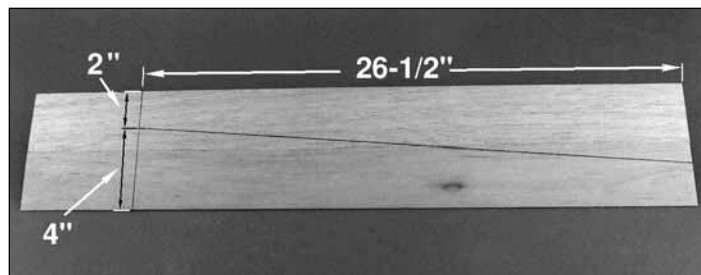

12. Cut the sheet as shown in the photo to make a top and a bottom LE wing sheet.

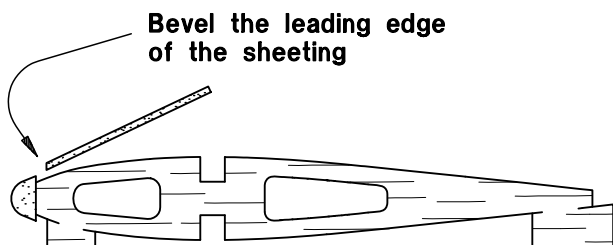

13. Fit one of the leading edge sheets to the bottom of the wing panel by first sanding a bevel on the front edge

of the sheet so it matches the leading edge of the wing, then trim the aft edge of the sheet so it "ends" at about the middle of the main spar.



14. Before you glue the LE sheeting in position, remove the T-pins from the front jig tabs in the wing ribs. Reinstall the T-pins through the top main spar and into your building board.

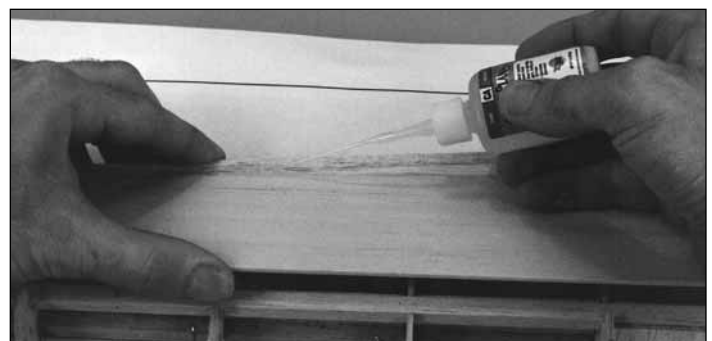

15. Wet the outside of the leading edge so it will bend easier.

Hint: a 50/50 mix of water and alcohol or ammonia helps soften the wood fibers so the sheet is even easier to bend. Position the front of the sheet against the LE and glue it in position with thin CA. Wet the sheet once more.

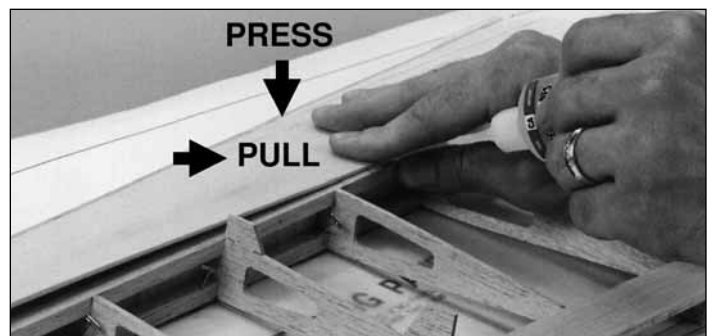

16. Carefully lift the sheeting away from the ribs, then apply a bead of medium or thick CA to the top of each rib.

Working quickly, *pull* the sheeting back toward the main spar as you *press* it down to the ribs and spar, then glue the aft edge of the sheeting to the main spar with thin CA. Use masking tape, T-pins or weights to hold the sheeting to the ribs until the CA cures.

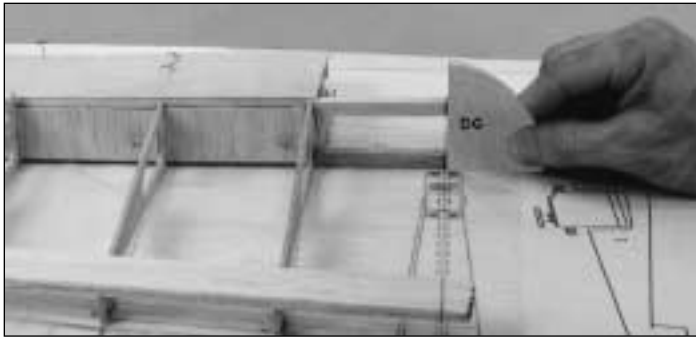

□ □ 17. Use the die-cut 1/8" plywood **dihedral gauge** and a ballpoint pen to **accurately** mark the wing centerline on the spars, TE and bottom TE sheet.

□ □ 18. Remove the T-pins, then take the wing off your building board.

Repeat steps 1 through 18 to build the left wing panel over the **right** wing panel drawing on the plan.



□ 4. Test fit the 1/8" x 1-3/8" x 5-3/8" ply spar joiners on the front and rear of the spars and temporarily clamp them in position.

□ 5. Make sure the ends of the spars and TE's join without any gaps. If there are any gaps, use your bar sander to make small adjustments to the ends of the spars. Whatever adjustments you make, the lengths of the spars and TE's must be identical so you do not build any "sweep" into the wing. In other words, when you temporarily clamp the spar joiners to the spars, you should not have to pull the TE's together, nor should they be pushing against each other.



□ 6. Glue the spar joiners to the spars with 30-minute epoxy by spreading a film of epoxy on both the spars and the spar joiners. Once the C-clamps are tightened wipe away excess epoxy. Place waxed paper under the center of the wing to catch excess epoxy and place weights on top of your wing to hold the jig tabs down. Glue the TE's together with thin or medium CA. Do not disturb the wing until the epoxy cures.

Join the Wing Panels

□ 1. Use a razor saw to accurately cut the spars, TE and bottom TE sheeting of both wing halves along the lines you marked at the wing centerline. At the wing tips, trim the spars, LE and bottom sheeting so they are even with rib R-10.

□ 2. Trim the bottom LE sheeting and the LE so they are even with rib R-2.

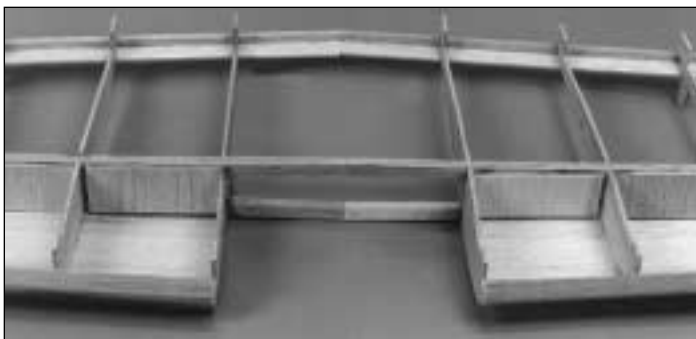

□ 3. Without using any glue, test join the wing panels by laying them upright (on the tall jig tabs on the bottoms of the ribs) on your flat building table and join the ends of the spars and TE.

Sheet the Wing



□ 1. Glue the two R-1 ribs together with medium CA. Fit the laminated R-1 rib between the aft spar joiner and the

TE at the wing centerline as shown on the plan—the bottom of R-1 at the front should align with the bottom spar. Check for proper positioning, then glue the rib in position with thin or medium CA.

❑ 2. Use a hobby knife to remove the top jig tabs (the small ones on every rib), then use your bar sander to sand away any remaining jig tab “stubs.” If needed, use your bar sander to remove any glue blobs and trim the shear webs so they are even with the top spar.



❑ 7. Cut the $3/32"$ x $3"$ x $36"$ balsa sheet into one $17-1/4"$ sheet and one $18-3/4"$ sheet. Cut the $17-1/4"$ sheet in half and use each piece to sheet the forward portion of the top center section of the wing on both sides of the aileron servo tray. Note that the end of the sheets at the front extend approximately $3/32"$ before they reach rib R-4 and the end of the sheets at the rear extend approximately $3/32"$ past rib R-3. Fit the sheets to the wing, then glue them in position with medium CA.

Hint: The “curve” in the sheet doesn't have to match the plan exactly but once you cut the first sheet, use the piece you cut as a pattern to make the curve in the ends of the other sheets.



❑ 3. Replace the wing on your flat building table so it is resting on the bottom jig tabs. Place weights on top of the wing to hold the jig tabs down. Make the left and right top LE sheets by gluing together two $3/32"$ x $3"$ x $30"$ balsa sheets, then glue them to the top of the wing the same as you did for the bottom.

❑ 4. Use two $3/32"$ x $7/8"$ x $30"$ balsa sheets to sheet the top TE of the wing.

❑ 5. Test fit but do not glue the die-cut $1/8"$ plywood aileron servo tray supports and the aileron servo tray in rib R-1. Adjust the cut-out in rib R-1 if needed so the aileron servo will fit.



❑ 6. Use medium CA to glue the aileron servo tray and supports in position, then glue the die-cut $1/8"$ plywood aileron servo tray doublers to the bottom of the aileron servo tray.



❑ 8. Use a $3/32"$ x $3"$ x $30"$ balsa sheet to sheet to the middle portion on the top center section of the wing. Save the rest of the sheet for the middle portion of the bottom center section.

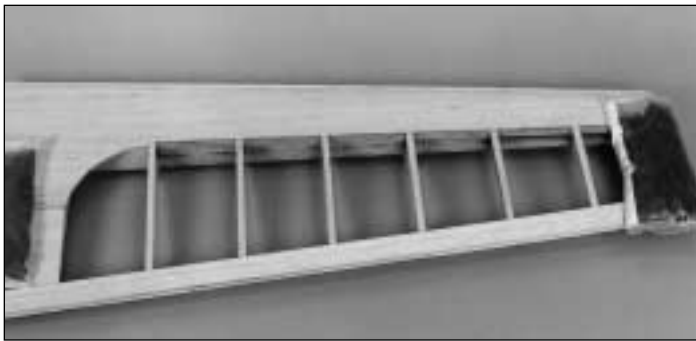

❑ 9. From the 3/32" x 1/4" x 24" balsa sticks cut cap strips, then use medium CA to glue them to the tops of all the ribs of both wing panels.

❑ 10. Remove the weights from the wing then flip it over. Use your hobby knife and a bar sander to remove the bottom jig tabs.

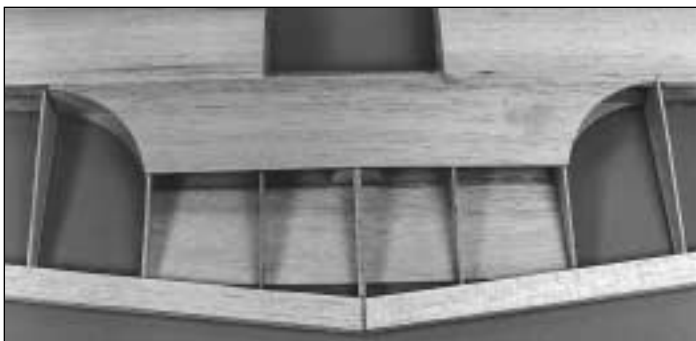

❑ 11. Use the 18-3/4" balsa sheet left over from step 7 to sheet the front portion of the bottom center section. Use your pattern to cut the curve at each end.

Note: Although the wing does have dihedral, it is minimal so you can still sheet the front and middle center sections with two sheets of balsa. This eliminates a glue joint in the center of the wing and adds strength. It also eliminates the need for glass cloth.

❑ 12. Use the remaining approximately 15" long balsa sheet left over from step 8 to sheet the middle portion of the bottom center section the same way you did the top.

❑ 13. From the five sheets of 3/32" x 3" x 24" balsa supplied with the kit, select the softest and clearest sheet. Reserve this sheet for the turtle deck sheeting on the fuselage and separate it from the others.

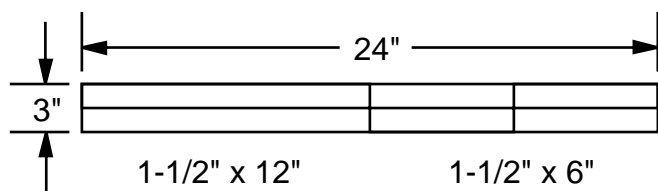

❑ 14. Cut a 3/32" x 3" x 24" balsa sheet into two 1-1/2" x 12" sheets and four 1-1/2" x 6" sheets.

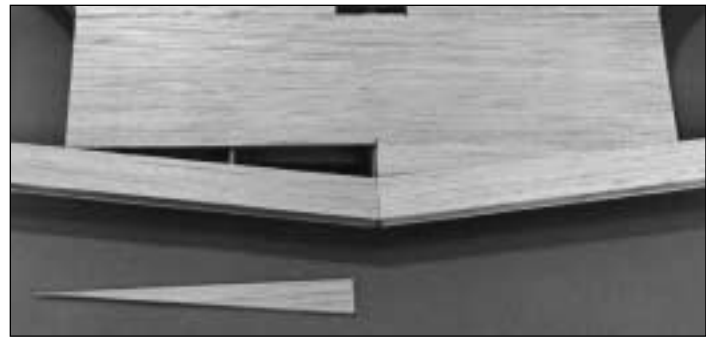

❑ 15. Fit, then glue the four 1-1/2" x 6" sheets to the aft portion of the top and bottom center section of the wing. Save the two 1-1/2" x 12" sheets for the wing belly pan which will be built after the wing is mounted to the fuse.

❑ 16. From the 3/32" x 1/4" x 24" balsa sticks cut cap strips, then use medium CA to glue them to the bottoms of all the ribs of both wing panels. Fill the small space behind the servo tray with leftover 3/32" balsa.

Build the Ailerons

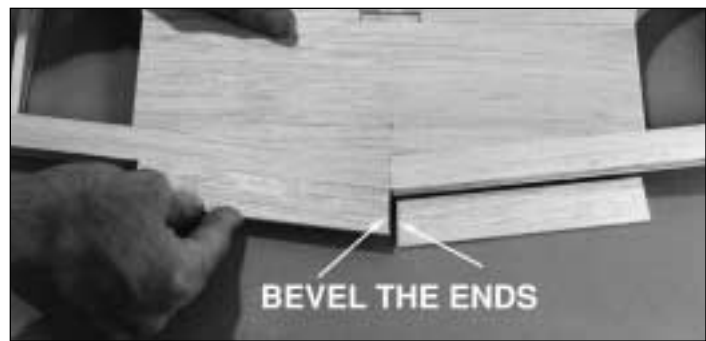

❑ 1. Bevel the ends of the tapered, grooved balsa **center trailing edges** so they join as shown on the plans. Test fit the center TE's on the wing.



❑ 2. Place the center TE's over the wing plan and mark the location of the **aileron torque rods**. Cut notches at the marks to clear the torque rods. Test fit the torque rods to make sure the notches allow enough clearance.

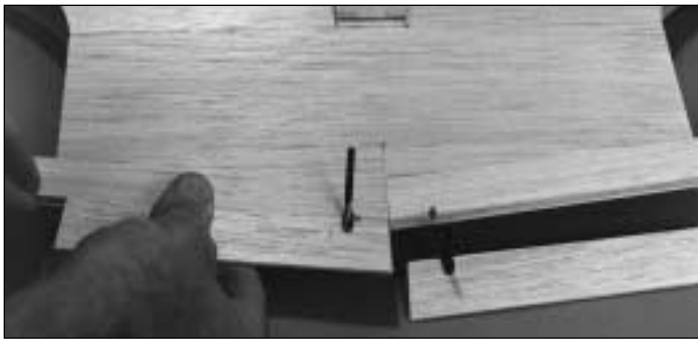

❑ 3. Position the center TE's on the wing TE with the torque rods installed, then mark the location of the notches on the wing TE. Cut the notches in the wing TE at the marks you made. Test fit the center TE's with the torque rods to make sure the notches align and are large enough to allow for proper aileron deflection.

❑ 4. Use coarse sandpaper to scuff the **nylon tube bearings** on the **aileron torque rods** so the glue will stick.

❑ 5. Use 30-minute epoxy to simultaneously glue the nylon bearing tubes in the center TE's and glue the center TE's to the wing. Tape the TE's to the wing until the epoxy cures. Wipe away excess epoxy before it cures and do not let epoxy get into the nylon bearing tubes.

Hint: Before gluing, use a tooth pick to apply a dab of petroleum jelly to the ends of the nylon tubes to keep the epoxy out.

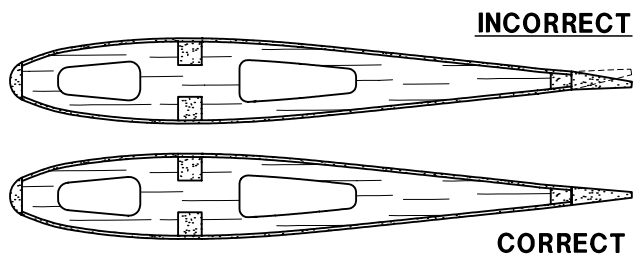

❑ 6. Cut 1" from each shaped 24" aileron. Test fit the 1" **wing tip trailing edges** and make sure they are aligned as shown in the sketch. Make adjustments if necessary, then glue the tip TE's in position with medium CA.

❑ 7. Use a razor plane and your bar sander to shape the LE's of the wing as shown on the plan.



❑ 8. Use your bar sander to sand the ends of the wing flat and even with ribs R-10.



❑ 9. Use a ballpoint pen to trace the outline of both wing tips onto one of the 3/16" x 1-3/4" x 10" balsa sheets.



❑ 10. Cut the wing tips from the sheet slightly oversize, then use medium CA to glue them to the wing. Use your bar sander to shape the wing tips to match the contour of the wing.



torque rod, then cut a groove in the front of the aileron for the torque rod. Use the same 1/8" sharpened brass tube you used for the elevator joiner wire.

- ☐ ☐ 15. Test fit the aileron in the wing to make sure the torque rod fits and there is approximately 1/16" clearance between both ends of the aileron and the wing. Make adjustments if necessary.

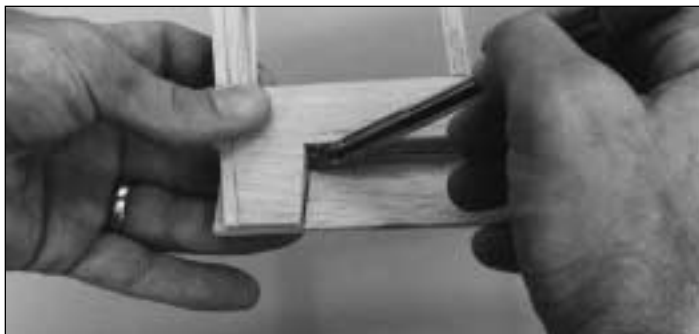

- ☐ ☐ 16. Mark the location of the hinges on the aileron and the wing. Cut the hinge slots, then test fit the aileron to the wing with the hinges.

- ☐ ☐ 17. Remove the aileron from the wing. Mark the "bevel to" lines and shape the leading edge of the aileron to a "V" as shown on the plan the same way you did for the elevator and the rudder.

- ☐ 18. Perform steps 11 through 17 to fit the right aileron to the wing.

- ☐ 19. Use light weight balsa filler such as HobbyLite to fill glue joints or dents in the wing. After the filler has fully dried use your bar sander to sand the wing using progressively finer grades of sandpaper so it is smooth and all the joints are blended.

Nice looking wing! Wait until you join it to an equally aesthetically pleasing fuselage.

- ☐ ☐ 11. Position the left aileron on the trailing edge of the wing, then mark the location of the torque rod and the end of the aileron where it meets the tip trailing edge.

- ☐ ☐ 12. Cut the aileron approximately 1/16" shorter than the mark you made at the tip so it will fit in the wing.

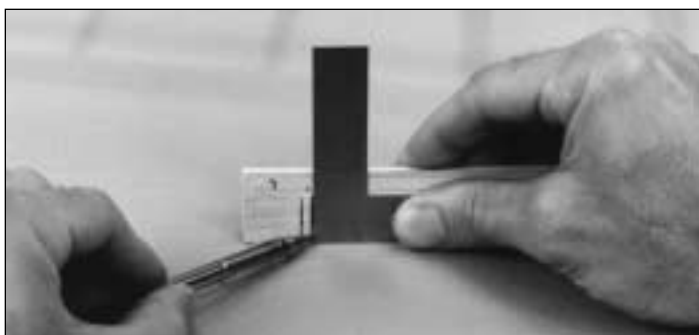

- ☐ ☐ 13. Use a drafting square or triangle to extend the marks to the front of the aileron, then use the "centerline technique" we've shown you before to mark the centerline on the entire leading edge of the aileron.



- ☐ ☐ 14. Use the centerline and the marks you made earlier as a guide to drill a 1/8" hole in the aileron for the

BUILD THE FUSELAGE

Note: All the fuselage parts from step 1 through step 25 are die-cut 1/8" plywood.

Assemble the Fuselage Sides

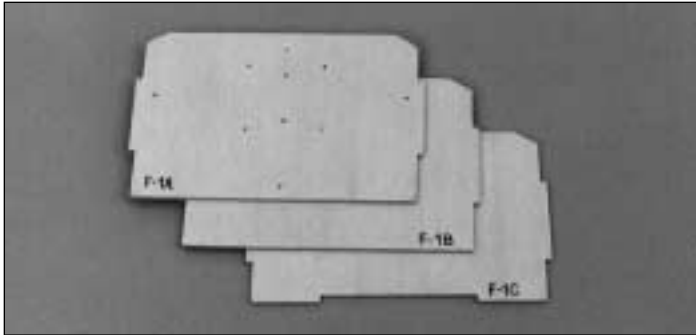

❑ 1. Use 30-minute epoxy to glue the **firewall formers F-1A, F-1B and F-1C** together. Make sure the **embossed label** on each former is facing **forward** and the top edges and notches of each former are aligned. Wipe away excess epoxy before it cures. From now on this assembly will be referred to as the **firewall**.

Note: If the formers are warped, simply clamping them together may not "cancel out" the warps. It is best to clamp the formers to a table or a flat board.

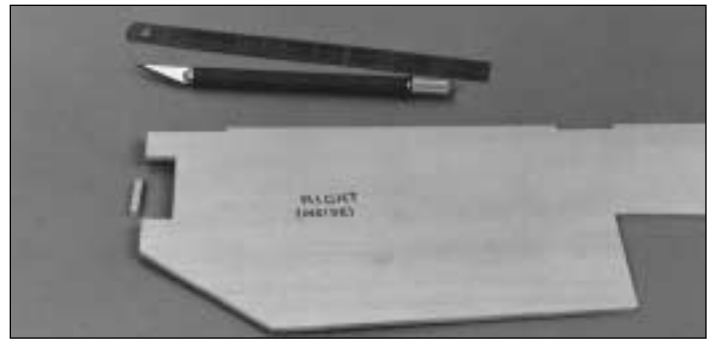
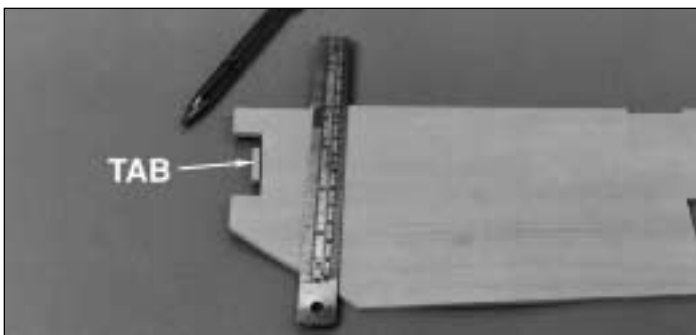

❑ 2. Use a straightedge and a ballpoint pen to draw a line across the **tab** connecting the notches in the front of **one** of the **fuselage sides**. Use the line as a guide to remove the tab with a #11 knife blade. As shown in the photo, label this as the **RIGHT** (inside) fuselage side.

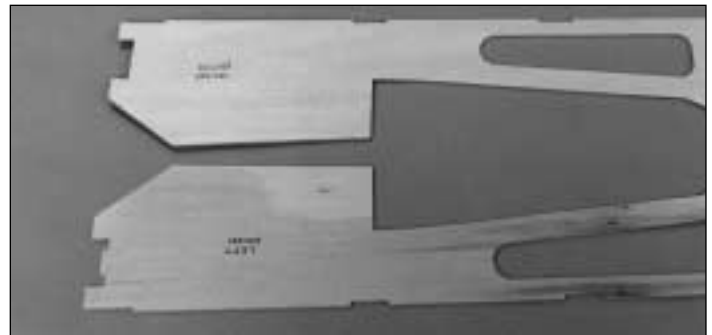

❑ 3. Lay the other **fuselage side** next to the right side **in a mirrored image** and label it on the inside as the **LEFT**. It is important that you lay the fuselage sides in a mirrored image to insure that you build a right and a left.



❑ 4. Use medium CA to **accurately** glue the **RIGHT fuselage doubler** (labeled "R") to the **inside** of the **right** fuselage side. Make sure the doubler aligns with the fuselage side at the points indicated by the arrows in the photo.

❑ 5. Glue the left fuselage doubler to the left fuselage side in the same manner.

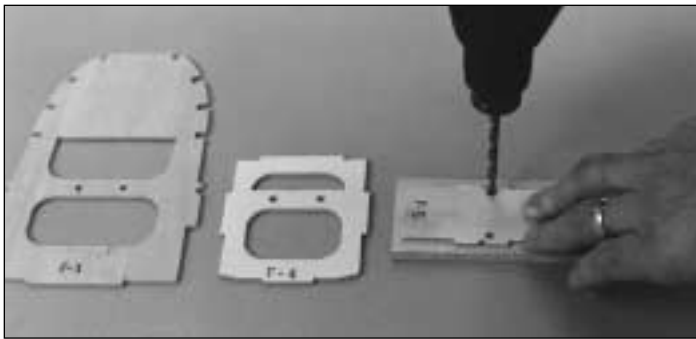

❑ 6. Drill a 3/16" hole through each of the punch marks in formers **F-2B, F-3, F-4** and **F-5**.

Hint: Place the formers on a leftover piece of wood and press down as you drill the hole so the wood does not split when the drill goes through.

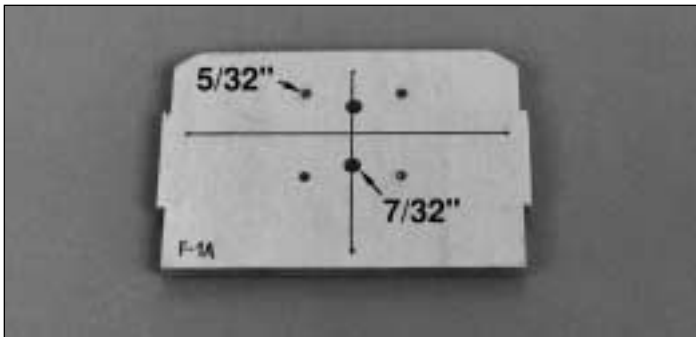

❑ 7. Draw centerlines connecting the outer punch marks on the **firewall**. Drill 5/32" holes for the engine mount bolts at the four engine mount punch marks. Drill 7/32" holes at the fuel line punch marks for the Great Planes 10 oz. fuel tank. If you will be using a fuel tank or engine mount other than Great Planes do not drill the holes in the firewall for the fuel lines until later on in the fuselage construction after the engine is mounted and you have your fuel tank.

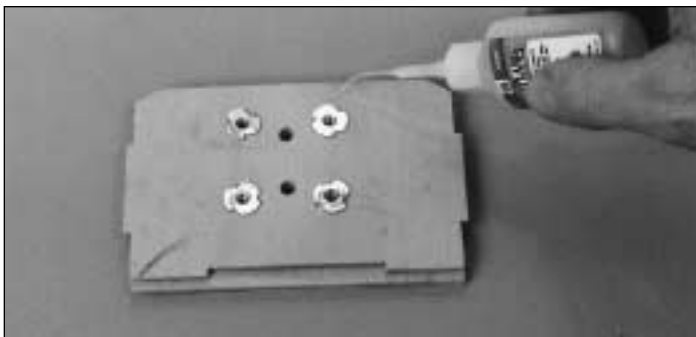

❑ 8. Press four supplied **6-32 blind nuts** into the holes on **back** of the engine mount. Gently tap the blind nuts with a hammer to fully seat them into the firewall, then add a few drops of thin CA around each blind nut to secure them.

The interlocking construction of Great Planes kits allows you to quickly assemble the fuselage while maintaining alignment. You will be fitting nearly all of the die-cut fuselage parts together before applying glue. **Do not use any glue until instructed to do so.**

❑ 9. Place former F-5 over the cross section drawing of F-5 on the plan. Use a ballpoint pen to accurately transfer the marks on the plan that indicate the ends of the turtle deck stringers onto F-5.

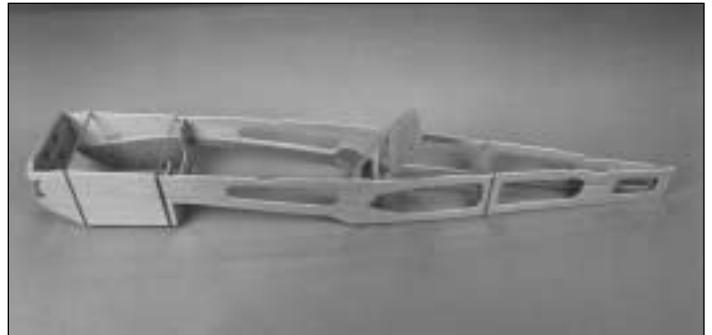

❑ 10. Fit the fuselage sides together, then place three rubber bands around them. **Without using any glue** insert the firewall and formers F-2B and F-3 between the fuselage sides in their prospective locations.

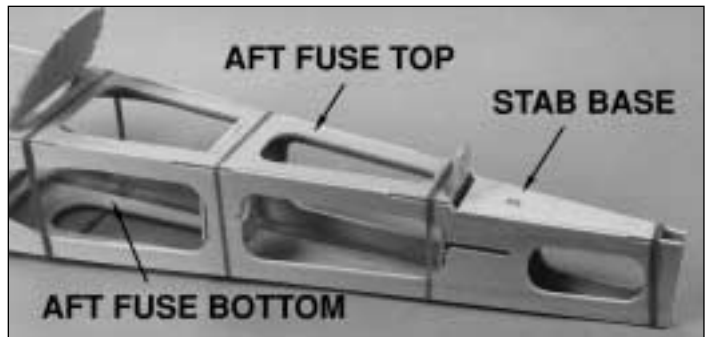

❑ 11. Install the **aft fuselage top**, then formers F-4 and F-5, the **aft fuselage bottom**, then the **stab base**. Add rubber bands as needed.

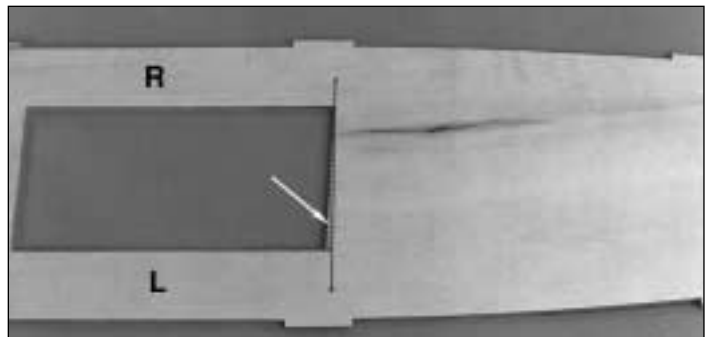

❑ 12. Use a ballpoint pen and a straightedge to draw a line connecting the punchmarks at the aft edge of the opening on the **forward fuselage top**, then remove the shaded area shown. Mark the "R" and "L" on the fuse top as shown in the photo.

❑ 13. Temporarily remove the firewall, then install the forward fuselage top. Make sure the "R" and "L" on the fuselage top are aligned with right and left fuse sides. Reinstall the firewall.

❑ 14. Use medium CA to glue the two die-cut 1/8" birch ply **landing gear plates**, then **without using any glue** fit the landing gear plate to **landing gear formers A (LGF-A)** and **B (LGF-B)**. Fit the assembly into the fuselage as shown on the plan and the following photo.

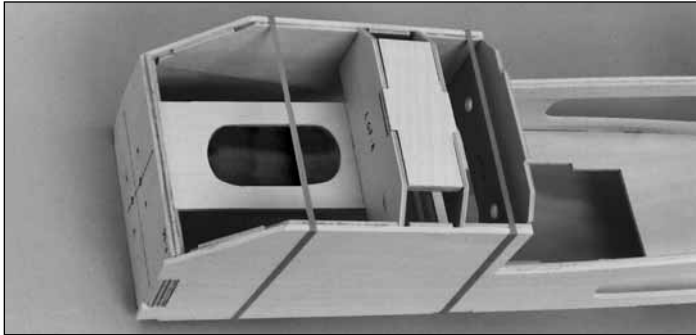

❑ 15. **No gluing yet.** Fit the **tank floor** to the firewall and LGF-A so the angle at the front of the tank floor matches the right thrust angle of the firewall.

❑ 16. Test fit former **F-1D** to the bottom of the fuselage in the location shown on the plan. **Note:** On the left side of the fuselage F-1D fits *behind* the firewall but on the right side of the fuselage F-1D fits **below** the firewall. Bevel the forward edge of F-1D where it contacts the firewall for the best fit. Slip the **forward fuselage bottom** under the rubber bands and position it on the bottom of the fuselage with the punch marks facing outward.

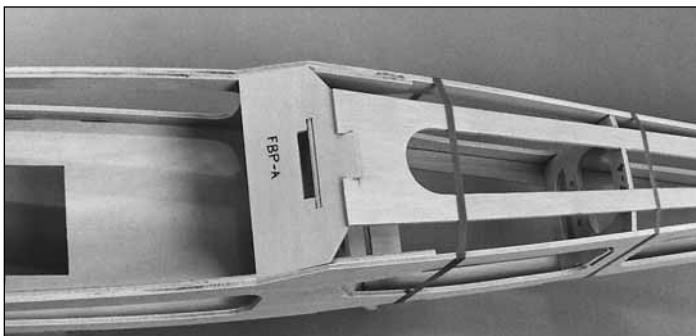

❑ 17. Temporarily fit the **fuselage bolt plate A (FBP-A)** to the aft fuse bottom and F-3.

We're almost ready to start gluing. There's just a few more things to do.

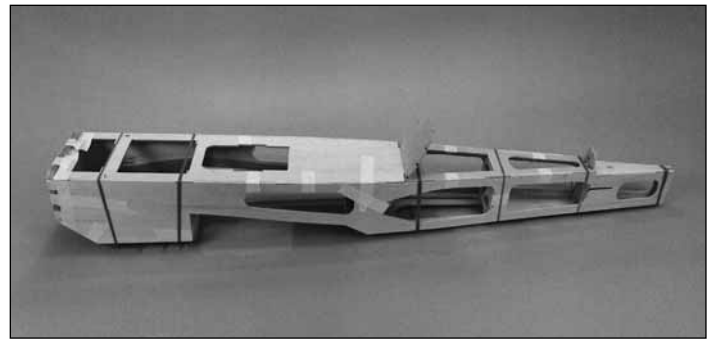

❑ 18. Use masking tape to **securely** hold all the fuselage pieces together. Tape the fuselage sides to the tops and bottoms and the formers to the sides. Not all of the fuselage pieces will be glued together at this stage but are held in position to assure alignment. **Only glue the parts you are instructed to do so in the next step.**

❑ 19. Use thin CA to begin tack gluing the following pieces checking alignment as you go. Glue former F-2B to the fuselage sides but **not the forward fuselage bottom**. Glue the forward fuselage top to the fuselage sides between F-2B and F-3. Glue F-3 to the fuselage sides but **not** to FBP-A. Glue the aft fuselage top to the sides, then glue F-4 and F-5 to the sides, top and bottom. Glue the aft fuselage bottom to the sides at the rear of the fuselage—the bottom fits *between* the fuselage sides not underneath them. Glue the stab base in position with 30-minute epoxy. **Do not apply any glue to FBP-A, LGF-A or B, the forward fuselage bottom, F-1D, or the firewall.**

❑ 20. Remove the masking tape and all the rubber bands. Remove the firewall, F-1D, the forward fuse bottom, the landing gear plates and LGF-A and B. Keep the stab base taped to the fuse sides until the 30-minute epoxy cures.

❑ 21. Use 30-minute epoxy to glue the firewall and F-1D in position. Use masking tape, rubber bands or clamps to hold them until the epoxy cures. Cut two **2-5/8"** pieces from the 1/4"x1/4"x10" balsa stick to reinforce the corners behind the firewall.



❑ 22. Use 30-minute epoxy to glue the landing gear plates to LGF-A and B and LGF-A and B to the fuselage sides. Without using any glue, **temporarily** install the tank floor to set the position of LGF-A.

❑ 23. After the epoxy from the two preceding steps has **fully cured**, remove the tape and rubber bands. Glue the forward fuselage top to the fuselage sides forward of F-2B.

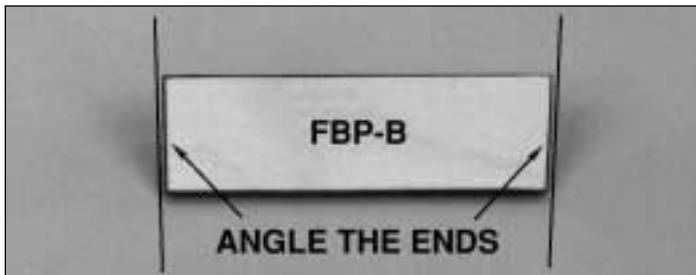

❑ 24. Remove the FBP-A from the aft end of the wing saddle area. Test fit the shaped 1/4" x 1-3/8" x 4-1/2" plywood **fuselage bolt plate B (FBP-B)** between the fuselage sides where shown on the plan. Use your bar sander to angle the ends of the bolt plate so it matches the angle of the fuselage sides.



❑ 25. Use 30-minute epoxy to simultaneously glue FBP-B and FBP-A to each other and the fuselage. After the epoxy cures, glue FBP-A to the aft fuselage bottom by adding a fillet of medium CA to the notches. Use your bar sander to bevel the forward edge of the fuse bottom so it is flush and matches the angle of FBP-A.

❑ 26. Cut both of the 36" **outer pushrod guide tubes** to a length of 24". Carefully (so you don't snap them in two) sand the outside of the tubes with coarse sandpaper so the glue will stick.

❑ 27. Use a round file or a #11 knife to bevel the holes in F-3 so the guide tubes will slide through. Install the guide tubes in the formers. Approximately 1" of the guide tubes should protrude past the slots in the aft end of the fuselage sides.



❑ 28. Glue the pushrod tubes to the slots at the end of the fuselage with microballoons and epoxy. Completely fill the

slot with the microballoons and epoxy so it can be sanded flush later. Glue the pushrod tubes to the formers with medium CA.

Note: Talcum powder may be substituted for microballoons.

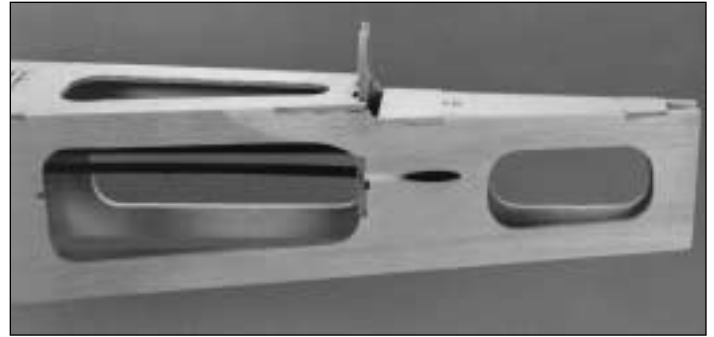

❑ 29. After the epoxy has cured use your bar sander and 150-grit sandpaper to sand the pushrod tubes and epoxy filler flush with the fuselage sides.

This is as much as we can do to the fuselage until we mount the wing. From this point on it helps to have a cradle or a box that you can place the fuselage onto upside down while you mount the wing.

Mount the Wing to the Fuselage

Refer to the fuselage plan often to make sure you understand the location of the parts discussed in the following steps. Unless otherwise noted, all the parts referred to while mounting the wing to the fuselage are die-cut 1/8" plywood.

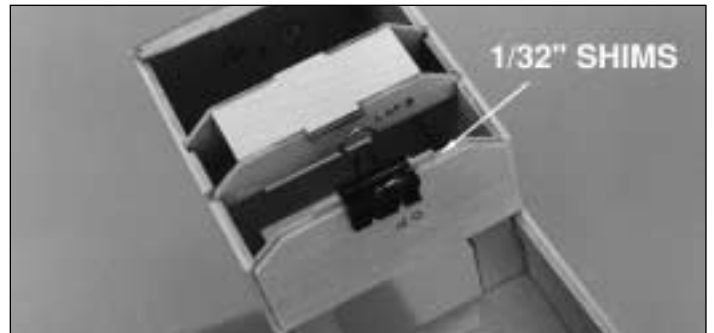

❑ 1. **With the punch marks facing forward**, temporarily clamp the **dowel plate (DP)** to F2-B so the edges align, with an approximately 1/32" shim in between. You may use playing cards, business cards or similar thin card stock for the shim. Place the wing in the fuselage. The wing should be nearly final sanded at this point.

❑ 2. Cut the 3/16" x 1-3/4" x 10" balsa sheet into two 5" long pieces for the **wing root spacers**. Position one of the 3/16" wing root spacers between the wing and the fuselage so the aft edge of the spacer is fully contacting the forward wing joiner. Use a ballpoint pen to mark the position of the spacer on the fuselage.

❑ 3. Perform the same procedure for the remaining 3/16" wing root spacer between the other side of the wing and the fuselage.

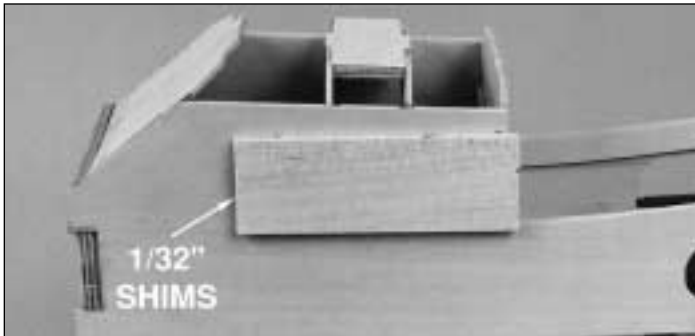

❑ 4. Remove the wing, then tack glue both wing root spacers to the fuselage in the locations you marked with an approximately 1/32" thick shim between the spacers and the fuselage. *After the wing is mounted to the fuselage the wing root spacers will be permanently glued to the wing for a perfect gap between the wing and the fuselage sides.*

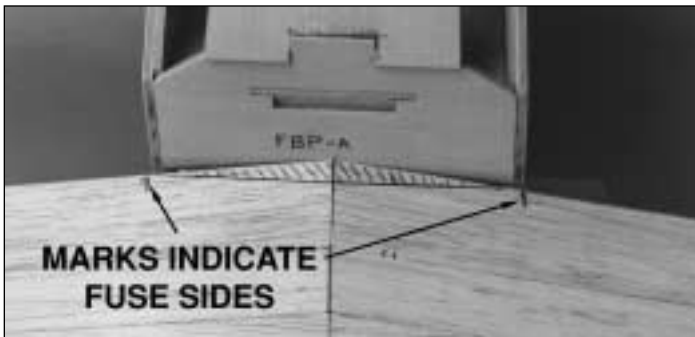

❑ 5. Place the wing back in the fuselage and center it. Use a ballpoint pen to accurately mark the TE of the wing directly above the fuselage sides.



❑ 6. Use a bar sander and a hobby knife to remove material as needed between the marks you made (indicating where the wing meets the fuselage) until the top of the wing fully contacts the fuselage sides and the TE clears FBP-A.

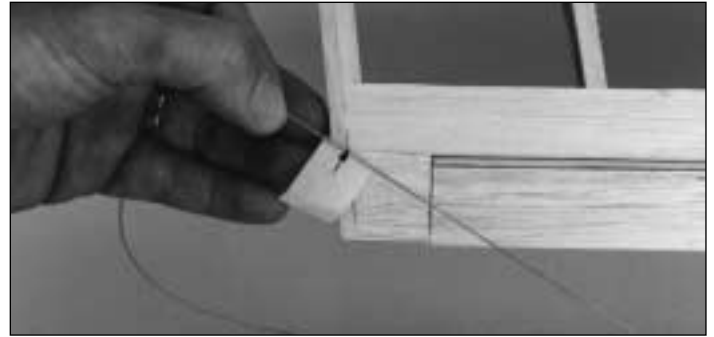
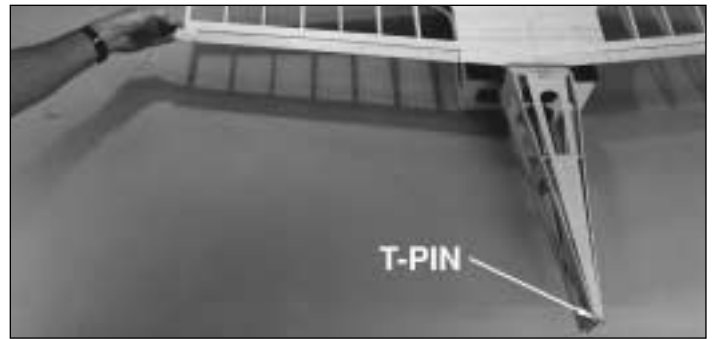

❑ 7. Align the wing by sticking a T-pin through the center of the aft end of the fuselage bottom. Tie a piece of monofilament line to the pin. Pull the line to the wing tip and put a piece of masking tape on the line at the wing tip. Put an arrow on the tape, then slide the tape on the line so the arrow aligns with a reference point, say the end of the trailing edge sheeting. Swing the line over to the other tip and see if it aligns with the same point. If necessary, shift the wing and mark the location of the tip by adjusting the position of the tape on the line. Do this until the arrow on the line aligns with both reference points at both tips.

❑ 8. Now that the wing is accurately aligned, adjust the notch you made at TE if needed so it clears the fuselage sides.

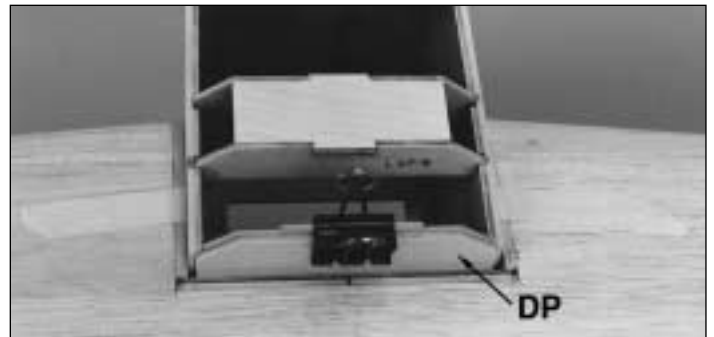

❑ 9. While the DP is clamped to F2-A and the wing is accurately aligned with the fuselage, use medium or thin CA to glue the DP to the wing.

Note: *Disregard the shaped wing root spacers in the following photos. They should still be tack glued to your fuselage and not yet shaped to fit the wing.*

- ❑ 10. Remove the wing from the fuselage and securely glue the DP in position. Using the punch marks in the DP as a guide, drill a 1/4" hole through the DP and only the front wing joiner. **Do not drill through the aft wing joiner.**



- ❑ 11. Slightly round one end of both 1/4" x 1-1/8" **wing dowels**, then use epoxy to securely glue them in position so the rounded ends are facing forward.



- ❑ 12. Drill a 1/4" hole through the punch marks in F-2A. After the epoxy from the previous step has fully cured, test fit F-2A on the wing dowels (it doesn't matter which way the notch faces). Make adjustments to the holes in F-2A if needed.

Hint: Even if the holes align perfectly with the dowels, it may be easier to install the wing for a days flying session if you **slightly** enlarge the holes in F-2A. You want the wing to easily slide into position, but with no free play.

- ❑ 13. Replace the wing into the fuselage. Recheck alignment. Use medium CA to glue F-2A to the front of F-2B. Refrain from allowing CA to contact the wing dowels.

- ❑ 14. Position the **wing bolt plate B (WBP-B)** on top of FBP-A at the trailing edge of the wing with a 1/32" shim between them.

- ❑ 15. Sand a bevel on the aft edge of the **belly pan bottom** to match the angle of FBP- A.

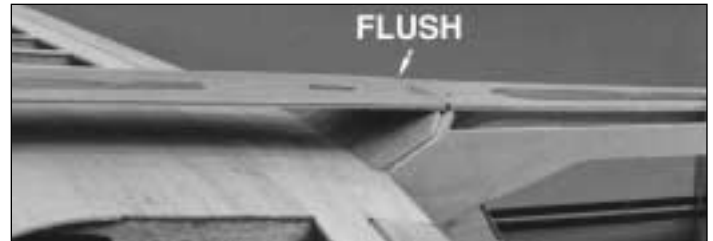
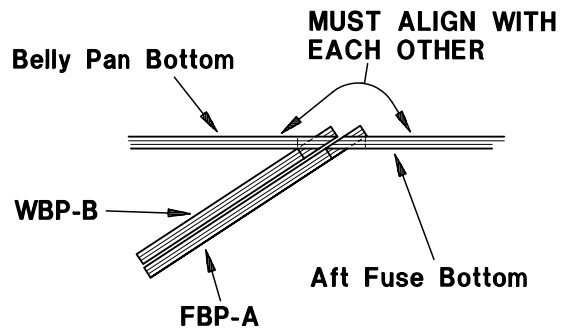

- ❑ 16. Position the aft edge of the belly pan bottom on WBP-B. Adjust the notch in the TE of the wing so that WBP-B can be positioned to allow the belly pan bottom to become flush with the aft fuse bottom.

- ❑ 17. Remove the belly pan bottom. Recheck the alignment of the wing, then carefully glue WBP-B **to the wing only**.

IMPORTANT: Hold the wing in alignment by clamping WBP-B to FBP- A & B until you drill the wing bolt hole (see photo below).

- ❑ 18. Test fit, then glue the **belly pan sides** to the wing sheeting and DP and WBP-B.

- ❑ 19. Test fit, then glue **WBP-A** to WBP-B and the belly pan sides.



- ❑ 20. Drill a #10 or 13/64" hole through the wing bolt plates (A & B) and the fuselage bolt plates (A & B).

- ❑ 21. Remove the wing, then tap the threads into the fuse bolt plates with a 1/4" x 20 tap. After tapping the fuselage bolt plates, saturate the threads with thin CA. **Allow the CA to fully cure**, then re-tap the threads.

- ❑ 22. Drill a 17/64" clearance hole through the wing bolt hole in the wing.

- ❑ 23. Mount the wing to the fuselage with the 1/4-20 nylon **wing bolt**.

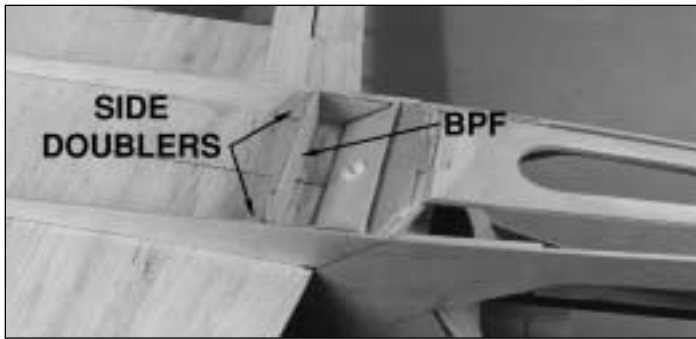

❑ 24. Test fit the **belly pan side doublers** and the **belly pan former (BPF)**. Glue them in position with medium CA.

❑ 25. Remove the wing and use your bar sander to bevel the top of **FBP-A** so it is flush with the fuse bottom. Bolt the wing back onto the fuselage.



❑ 26. Glue the belly pan bottom in position with medium CA.

Hint: fuelproof the wing bolt area and the under side of the belly pan bottom before gluing it into position.

❑ 27. While the wing is still in position, use medium or thick CA to glue the 3/16" balsa wing root spacers to the wing.



❑ 28. If needed, apply filler to the gap between the wing root spacers and the wing.

❑ 29. Remove the wing from the fuselage. You will have to break loose the wing root spacers as they were tack glued to the fuselage. After the filler has fully dried, sand the spacers and the filler to match the contour of the wing.

❑ 30. Fill the center section of the wing aft of DP on the top and bottom with 3/32" leftover balsa. Sand the filler pieces to match the contour of the wing.

Finish the Bottom of the Fuselage

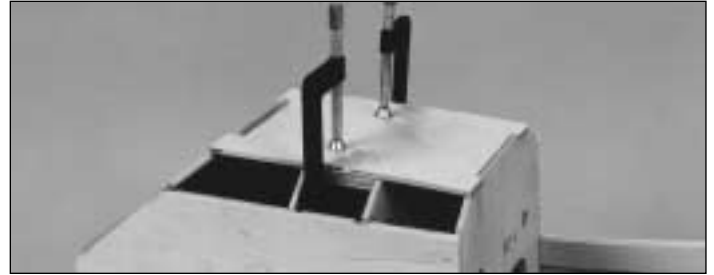

❑ 1. Use epoxy to glue the die-cut 1/8" plywood **forward fuse bottom** in position with the punch marks facing outward.

❑ 2. Drill a 3/32" hole through both punch marks in the forward fuse bottom and the LG plates.

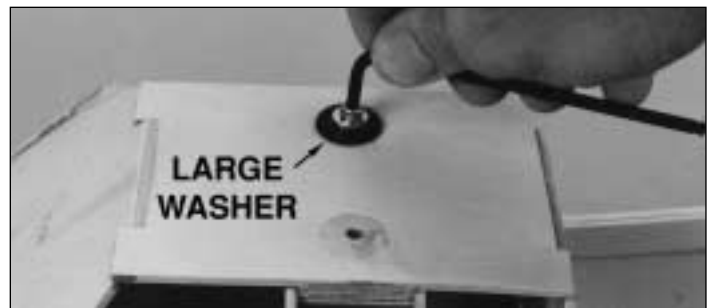

❑ 3. Install **8-32 blind nuts** supplied with this kit into the LG plates from inside the fuselage.

Hint: Draw the blind nuts into the LG plates by placing a large washer on one of the 8-32 x 3/4" socket head cap screws and tighten the screw. Remove the screw and apply thin CA around the nuts to permanently hold them in place.

❑ 4. Use your bar sander to bevel the edges of the fuselage sides, aft and forward bottom and the belly pan sides and bottom.

❑ 5. From the 3/32" x 3" x 30" balsa sheet make two 1-1/2" x 19-1/2" **chine sheets** and two 1-1/2" x 10-1/2" chine sheets.



❑ 6. Place one of the 19-1/2" chine sheets on the aft fuselage bottom "corner" and glue it to the fuse bottom and side with thin CA from the inside.

Hint: First "prime" the inside of the sheet with CA accelerator so the thin CA will cure immediately. Glue the balsa sheet first to the fuselage side, then to the bottom.

- 7. Glue the other chine sheet in position in the same manner.

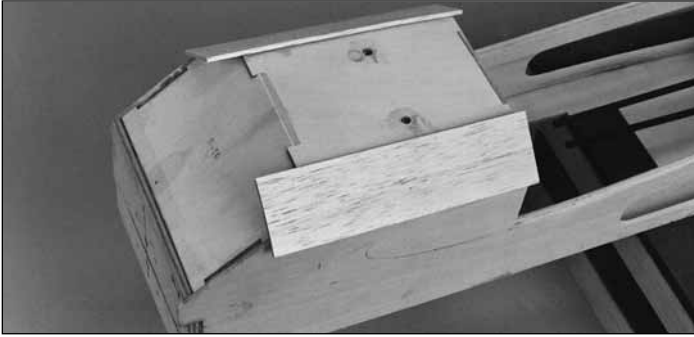

- 8. Glue the 10-1/2" chine sheets to the forward fuse bottom.

- 9. Locate the 3/32" x 1-1/2" x 12" sheets you cut at step 14 on page 17 under **Sheet the Wing**. Glue the sheets to the belly pan in the same manner you glued the other sheets to the fuse bottom.

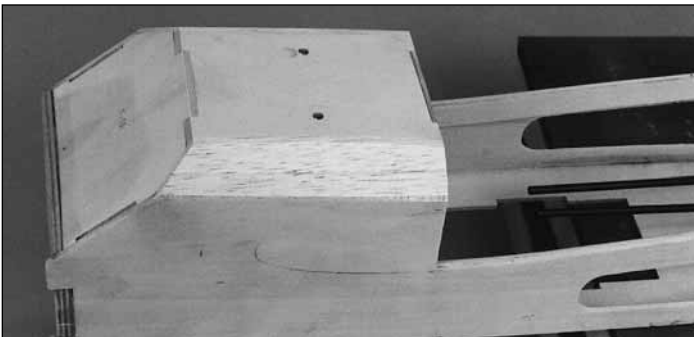
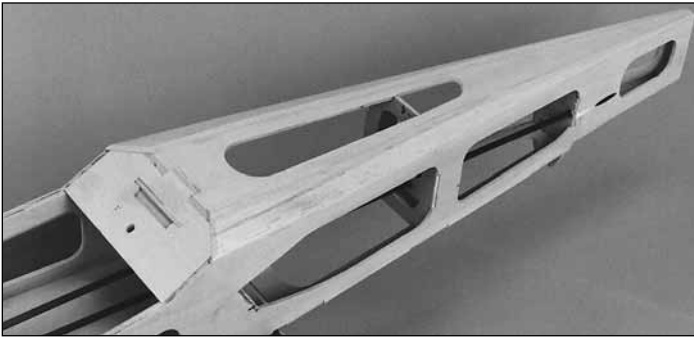

- 10. Use a razor plane and a bar sander to trim, then shape the chine sheets as shown on the cross sections of the fuselage plan. Reinstall the wing to **blend the chines** of the wing and fuselage.

- 11. Brush on a fuelproof coating inside the fuel tank compartment. Use epoxy paint, dope, thinned epoxy resin or finishing resin. Refrain from letting the paint get into the blind nuts.

- 12. Use your bar sander to sand the tabs and notches of the fuse bottom, wing bolt plates, fuselage bolt plates, belly pan and forward and aft fuselage bottom so they are flush and even. Test fit the wing and sand the chine sheets of the forward fuselage, wing belly pan and aft fuselage so they are even.

Build the Front Fuselage Deck

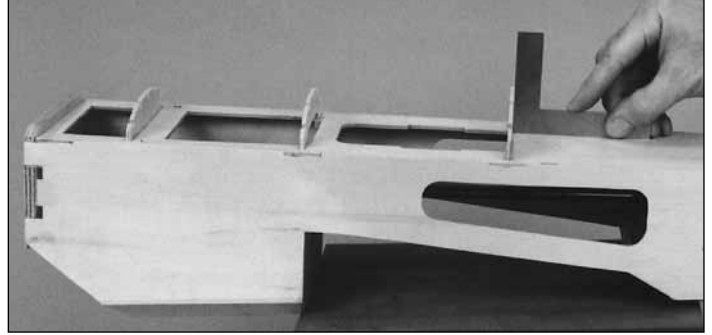

- 1. Use a 90 degree triangle or square to glue the die-cut 1/8" plywood **top formers F-1T, F-2T, IP and F-4T** to the fuselage top.

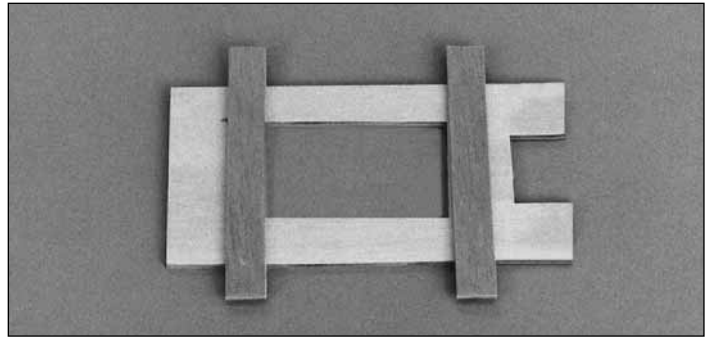

- 2. **Securely** glue two 3-1/2" long sticks cut from leftover 1/8" plywood to the **bottom** of the tank floor. These tabs are for hooking rubber bands onto for securing the fuel tank.

- 3. Glue the fuel tank floor in position, then test fit the fuel tank. The tank floor is positioned so that a Great Planes 10 oz. fuel tank with 1/4" foam rubber underneath, will align with the fuel line holes in the firewall. If you are using a different engine mount or fuel tank, make any necessary modifications now while the fuel tank compartment is still accessible.

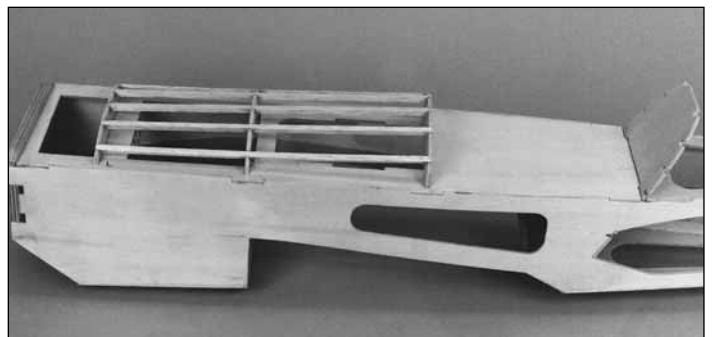

- 4. Glue five 3/16" x 3/16" x 12" balsa stringers in the notches in formers F-1T, F-2T and IP. Cut the ends of the stringers so they are even with the formers.

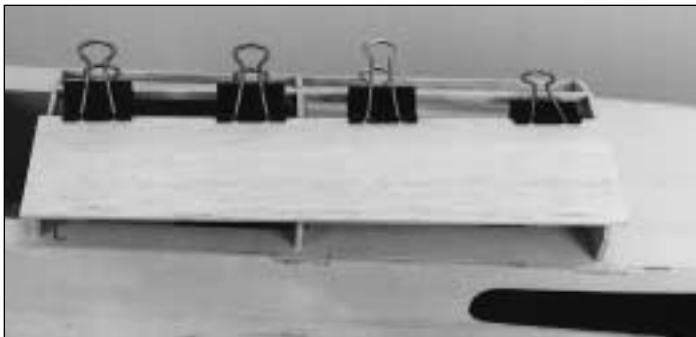

❑ 5. Cut a 3/32" x 3" x 24" balsa sheet into two 12" long pieces. Trim the edge of one of the sheets so it will not meet the fuselage side but will extend past the bottom stringer when it is bent around the formers and stringers. Use thin CA to glue the sheet to the center of the top middle stringer.

❑ 6. Wet the sheet with the water and alcohol solution, then carefully test bend it into position. Apply more water and alcohol if needed to bend the sheet.



❑ 7. Use masking tape to firmly hold the sheet in position, then glue it to the stringers with thin CA from inside the fuselage.

❑ 8. After the water has evaporated remove the tape, then fit and glue the other sheet to the fuselage.

❑ 9. Use your bar sander and 150-grit sandpaper to sand the sides of the front deck sheeting so they are even with the edges of the formers. Trim the ends of the sheeting so they are even with F-1T and IP.

❑ 10. Locate the 1/4" x 3/4" x approximately 22-1/2" balsa stick (it was 24" long but you used a little piece for the fin tip while building the tail surfaces a while back). Cut it into two equal length pieces for the **front deck side stringers**.



❑ 11. Use medium CA to glue one front deck side stringer to each side of the fuselage. Sand the side stringers so they blend the sheeting and fuse sides together as shown on the fuselage plan.

Mount the Stab and Fin to the Fuse

❑ 1. If you have not already done so, make sure the stab and fin are final sanded to a smooth finish as it will be a little more difficult to do so after they are glued to the fuselage.

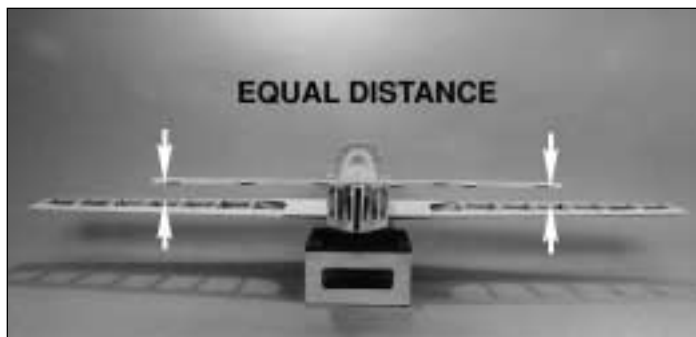

❑ 2. Mount the wing to the fuselage, then position the stab on the fuselage. Stand about six to ten feet behind the model and see if the stab is parallel to the wing. If necessary, use your bar sander to make adjustments by sanding the stab base until the stab is in alignment with the wing.

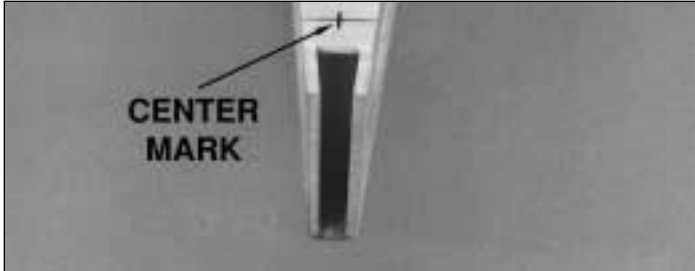

❑ 3. Accurately measure the trailing edge of the stabilizer and use a ballpoint pen to mark the center. Accurately mark the center of the stab base where the trailing edge of the stab contacts it.

❑ 4. Place the stab on the stab base with the center marks aligned, then use a large T-pin to pin **only the trailing edge** of the stab to the stab base.



❑ 5. Stick a T-pin through the forward fuse deck sheeting above F-1T in the center of the middle stringer, then use the "pin and string technique" to accurately align the stab with the fuselage. Once the stab is accurately aligned, pin the LE of the stab to the stab base.

❑ 6. Carefully turn the fuselage over and use a ballpoint pen to **lightly** mark where both of the fuselage sides contact the bottom of the stab.

❑ 7. Remove the stab from the stab base but leave the T-pins in the stab. Apply a film of 30-minute epoxy to the stab base and the stab between the lines you marked indicating the fuselage sides.

❑ 8. Reposition the stab on the stab base and reinsert the T-pins into the same holes. Use the pin and string to confirm the stab alignment, then use weights, more T-pins or clamps to hold the stab in position. Wipe away excess epoxy before it cures, then recheck alignment. Do not disturb the model until the epoxy cures.



❑ 9. If you haven't already done so, final sand the fin. Test fit the fin on the stab with the trailing edge of the fin between the fuselage sides. Adjust the length of the fin trailing edge so the base of the fin fully contacts the stab.

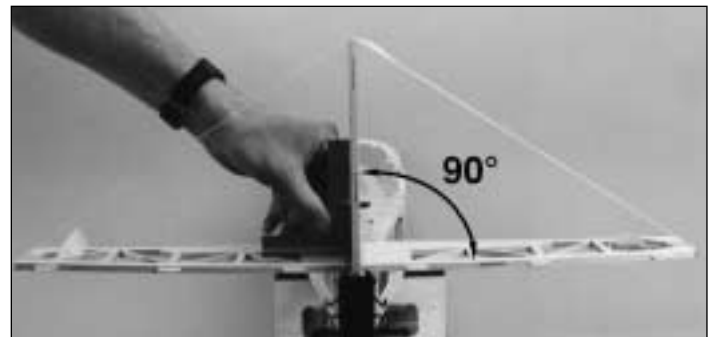

❑ 10. With the fin in position clamp the fuselage sides together and use a drafting triangle or square to check that the fin is perpendicular to the stab. Make adjustments if needed, then glue the fin to the stab and fuselage sides with 30-minute epoxy. Use the square to keep the stab perpendicular to the fin. Use masking tape to hold the fin in position until the epoxy cures.

Build the Turtle Deck

❑ 1. Accurately cut the 1/8" x 1/4" x 30" balsa stick into two 15" pieces for the bottom turtle deck stringers that run along both sides of the aft fuselage top. Glue the stringers in position so the front ends are even with F-3. The aft ends of the stringers should end approximately 1" in front of the trailing edge of the stab.



❑ 2. Use medium CA to glue the rest of the turtle deck stringers cut from the 1/8" x 1/4" x 24" balsa sticks to formers F-3, F-4T and F-5.

❑ 3. Accurately cut the turtle deck sheeting pattern from the fuselage plan. Use the pattern to make two turtle deck sheets from the 3/32" x 3" x 24" balsa sheet you set aside during wing construction.

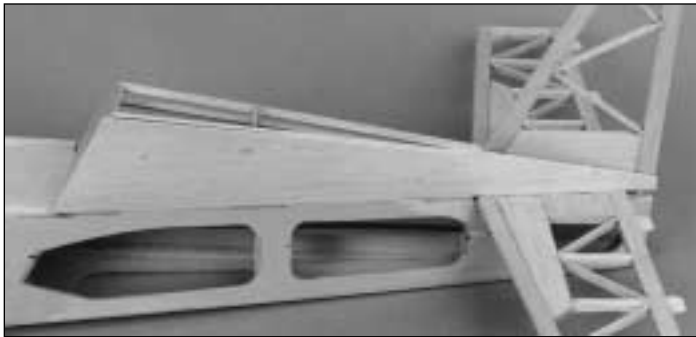

❑ 4. Test fit, then use medium CA to glue the bottom of the left side turtle deck only to the aft fuselage top, the bottom stringer and the stab.

❑ 5. Use a paint brush or paper towel to apply the water and alcohol solution to the outside of the turtle deck sheet. Little by little carefully test bend the sheet around the formers and stringers. If the sheet will not bend enough apply more water and alcohol and carefully keep test bending.



❑ 6. Once you can bend the sheet all the way around the formers and to the top stringer, use a sharp #11 blade to shave a bevel to the top edge of the sheet where it meets the fin. Notice that the angle of the bevel becomes more vertical toward the rear of the fin.

❑ 7. When you have achieved a good fit between the top of the sheet where it contacts the fin, use medium CA to glue the sheet to the fin. Bend the sheet around the stringers and formers, then use masking tape or clamps to hold it in position. Use thin CA to glue the sheet to the stringers and formers from the inside.

❑ 8. Fit, bend and glue the right turtle deck sheet into position the same way you did the left side. Since most of the stringers won't be accessible from the inside you will have to apply medium or thick CA to the stringers and formers **before** you bend and clamp the sheet into position.

❑ 9. Use your bar sander and 150-grit sandpaper to sand the top of the turtle deck fuselage sheeting so it is flat and even with the top stringers.



❑ 10. Use medium or thick CA to glue the 3/8" x 2-3/4" x 10-3/4" **turtle deck top sheet** in position.



❑ 11. Use your razor plane and your bar sander to shape the turtle deck top sheet to match the contour of the turtle deck and the shape shown on the plans. While carving and sanding, be **extremely careful** as you reach the fin so you do not accidentally nick it with your knife or sandpaper.



❑ 12. Fit and glue the cockpit sides from the 1/4" x 1/4" x 24" balsa stick.



❑ 13. Glue the die-cut 1/8" plywood **hatch cover supports** to the underside of the forward fuse top as shown on the plan. Test fit the hatch cover and make adjustments if needed. With the hatch cover in position, drill a 1/16" hole

through the hatch cover and supports where indicated on the plan, then remove the hatch cover and drill a 3/32" clearance hole through the holes **in the hatch cover only**.

Mount the Engine

❑ 1. Cut the "spreader bar" from the supplied Great Planes motor mount, then use a hobby knife to remove any flashing left over from the molding process so the halves fit together well.

❑ 2. Temporarily mount the engine mount to the firewall with four 6-32 x 1" Phillips head machine screws and #6 flat washers. Do not tighten the screws all the way so you can adjust the mount.

❑ 3. Place your engine on the mount and slide the halves in or out so the engine fits. Position the mount so the molded-in "tick marks" are equally spaced on the horizontal center line you drew that connects the punch marks on both sides of the firewall. When the engine mount is adjusted and positioned, tighten the mounting screws.

❑ 4. Position the engine on the mount so the drive washer (or the back of the spinner) is 4-3/4" away from the firewall. Refer to the Expert Tip that follows, then mark and drill the engine mounting holes for the #6 x 3/4" engine mounting screws.



HOW TO ACCURATELY MARK AND DRILL THE ENGINE MOUNTING HOLES ON THE ENGINE MOUNT

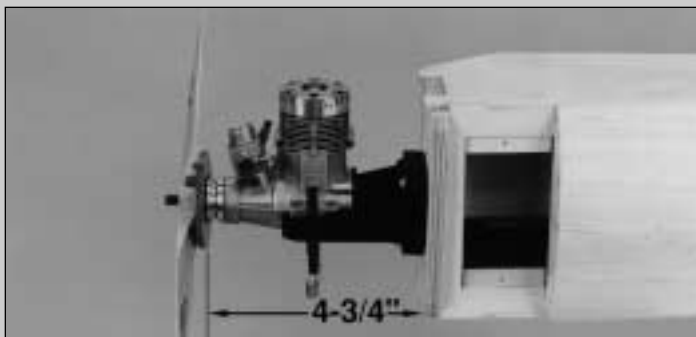

A. Use C-clamps to hold the engine in position.



B. Use a torch or a lighter to heat the end of a sharpened wire rod and mark the center of the engine mount holes. It just takes a little pressure of the heated rod to dimple the plastic.

C. Remove the engine, then use a pin vise or an electric drill to start the holes with a 1/16" drill bit.

D. Remove the engine mount from the fuselage. Use a drill press if you have one to drill the 7/64" holes, or use your hand held electric drill to drill the holes.

Optional: Modelers who prefer to mount their engine with machine screws instead of sheet metal screws should drill the engine mounting holes with a #36 drill, then tap the holes with 6-32 tap. 6-32 x 3/4" Screws (not supplied) are recommended.

❑ 5. Drill a 3/16" hole for the **throttle pushrod guide tube** at the suggested location indicated by the punch mark on the front of the firewall. This location will work for most two-stroke engines but if you are using a four-stroke engine or would like to change the location of the throttle pushrod, plan ahead and make sure you drill the hole so the throttle pushrod will not interfere with the fuel tank.

Install the Servos and Make the Pushrods

Note: The instructions and photos show the radio installation for a two-stroke engine. If you are installing a four-stroke engine, you may have to route the throttle pushrod in a location other than shown in this manual and arrange the elevator and rudder servos and pushrods accordingly. You may still use the following instructions as a guide and building sequence.

❑ 1. Use medium CA to glue the die-cut 1/8" plywood **servo tray** to the forward fuselage top in the location shown on the plan. Trim, then glue a die-cut 1/8" plywood **servo tray doubler** across the aft rail of the servo tray. You can see the servo tray in the photo at step 5.

❑ 2. Cut one of the outer pushrod guide tubes left over from the rudder and elevator guide tubes to a length of 7-3/4". Use coarse sandpaper to roughen the outside of the tube so the glue will stick.

❑ 3. Fit the tube through the hole you drilled in the firewall and former F-2B.

Note: If you are mounting a 4-stroke engine you may have to drill another hole in F-2B to reroute the pushrod.

Use this photo for the next three steps.

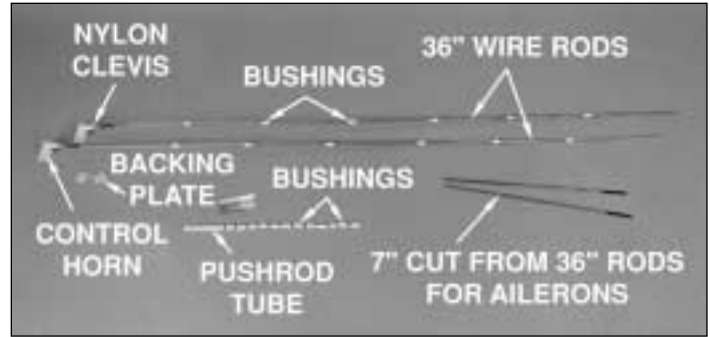

❑ 6. Cut 7" off one end of both 36" wire rods. Set the short pieces aside and save them for the aileron pushrods. Thread a nylon clevis about 20 turns onto the end of one of the long rods, then remove the **backing plate** from a nylon **control horn** and connect the horn to the clevis in the outer hole. Make another pushrod assembly from the other long rod with a clevis and control horn.

❑ 7. Cut twelve 3/8" **bushings** from the 6-1/2" plastic inner pushrod tube. Slide six bushings, evenly spaced, onto each pushrod. Adjust the bushings nearest the ends of the rods so they will not interfere with the ends of the guide tubes and possibly become jammed during flight. If the bushings slide onto the wires without much resistance use a drop of thin CA to hold them in position.

Hint: Before installing the bushings, use a cloth saturated with denatured alcohol or other solvent to wipe off the oil left on the wires from the manufacturing process.

❑ 8. Trim the plastic pushrod guide tubes that are glued into the fuselage so they "end" about 2" aft of the elevator and rudder servo arms. If you've used CA to secure the plastic bushings on the wire pushrods, make sure it has **fully** cured, then slide the pushrods into the guide tubes from the back of the fuselage.

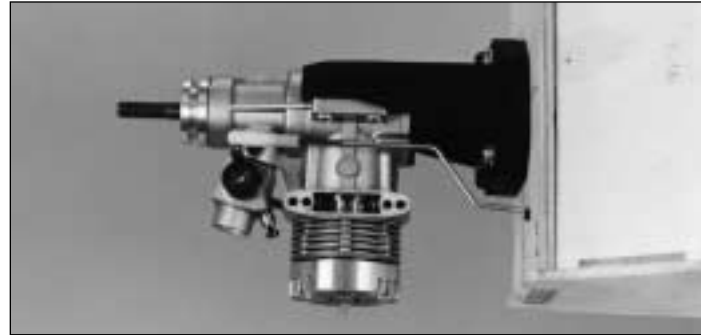

❑ 4. Bend and cut the 17-1/2" throttle pushrod wire to fit your engine installation using the drawing on the fuselage plan as a guide. Install a nylon clevis and insert the pushrod through the guide tube. Make adjustments to the bends in the wire so the pushrod aligns with the carburetor arm on the engine, then temporarily connect the clevis to the carb arm. Temporarily mount the muffler and make sure the throttle pushrod will not interfere with the muffler. Make adjustments to the bends in the wire if necessary.

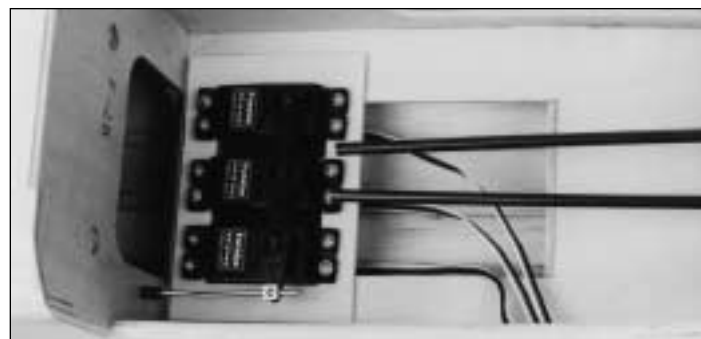

❑ 5. Install the servos in the servo tray spacing them apart as necessary so the servo arms do not interfere with each other. Temporarily install the brass Screw-Lock™ Pushrod connector in the throttle servo arm, then adjust the bend in the throttle pushrod if necessary and fit it into the connector.

Note: Some modelers prefer to install the pushrods and control horns **after** the model is covered. If this is your preference skip ahead to step 15. Return to step 6 after you have covered the model and joined the control surfaces to the model with the hinges.

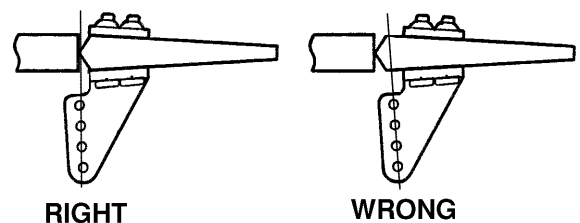



❑ 9. Position the control horns on the elevator and rudder as shown in the sketch and on the plan. Use a ballpoint pen to mark the location of the control horn mounting holes and drill $3/32$ " holes at the marks. Temporarily mount the control horns to the rudder and elevator with the backing plates and 2-56 x $5/8$ " screws.



❑ 10. With the servos centered and the control surfaces in neutral position, use a felt-tip pen to mark where the pushrods cross the mounting holes in the servo arms.



❑ 11. Disconnect the clevises from the control horns, then make a 90 degree bend at the marks you made. Temporarily install a nylon Faslink on each pushrod, then cut the wire so it slightly protrudes out of the Faslink.

Hint: If you prefer to bend and cut the pushrods **out of the fuselage** remove the pushrods, then make the 90 degree bends and cut the wire. Unscrew the clevises and reinstall the pushrods in the guide tubes from the front, then screw the clevises back on.

❑ 12. Connect the pushrods to the servos with the Faslinks.

Note: If necessary, enlarge the holes in the servo arms with a $5/64$ " drill bit (or a #48 drill for precision).

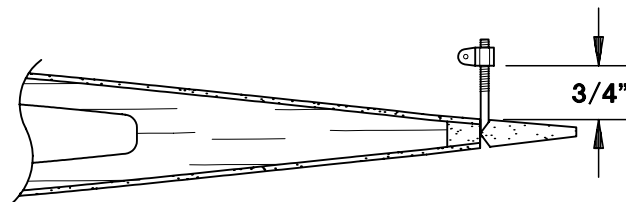

❑ 13. Mount the aileron servo in the wing, then thread the nylon **6-32 torque rod connectors** on the torque rods until they are $3/4$ " from the wing sheeting.

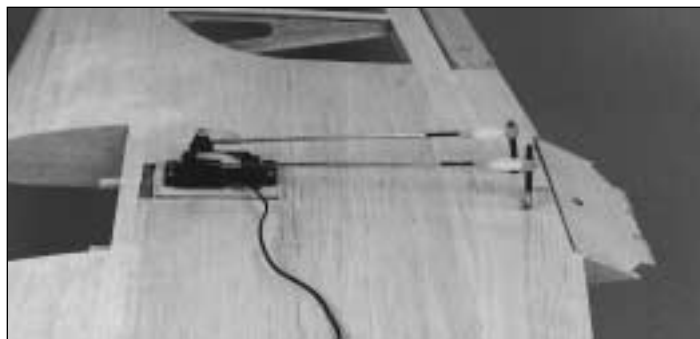

❑ 14. Use the 7" long wire rods cut from the 36" pushrods to make the aileron pushrods. Connect the pushrods the same way you did for the elevator and rudder with the nylon clevises and faslinks.

❑ 15. If you haven't already done so, sand the bottom of the rudder so it is even with the bottom of the fuselage, then round the bottom of the rudder to match the trailing edge. Mark the location of the **tail gear wire** on the rudder and the nylon **tail gear bearing** on the fuselage.



❑ 16. Remove the rudder and drill a $3/32$ " hole in the leading edge at the mark you made for the tail gear wire, then cut a groove for the nylon tail gear bearing (use a $5/32$ " brass tube sharpened at one end to cut the groove the same way we showed you for the elevators.) Test fit the tail gear wire in the rudder.



17. Cut a slot in the trailing edge of the fin at the marks you made for the nylon tail gear bearing. Without using any glue join the rudder to the fin with the tail gear wire.

Hint: Enlarge the slot with a small razor saw so the nylon bearing will fit easier.

Assemble the Wheel Pants



1. Trim one matching set of wheel pant halves along the molded cut lines. Notice that the **top** of the outer pant goes over the lip of the inner pant and the **bottom** of the inner pant goes over the lip of the outer pant. You can use a hobby knife to **carefully** score along the cut lines and flex the plastic until the excess breaks free, or use small scissors to cut along the lines. Kyosho curved Lexan cutting scissors (KYOR1010) work extremely well for this and make the job a cinch. For now, don't worry about accurately cutting out the opening in each wheel pant half – just cut an approximate opening for the wheels.

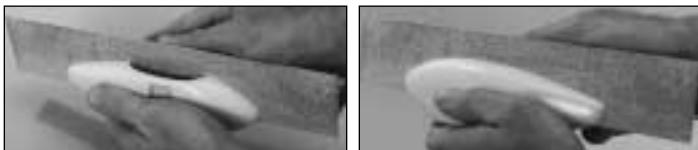

2. Use your bar sander to carefully true the edges of the overlapping pieces of the wheel pant halves so when you glue them together the seam will be as small and straight as possible. Notice that the front and rear of the pant halves do not overlap. Use 150 or 220-grit sandpaper to remove the flashing and **thoroughly** roughen all areas that are to be glued including the indentation on the inside of both inner pant halves.

3. Test fit the wheel pant halves and make adjustments where necessary for the best possible fit.

4. Join two wheel pant halves and carefully spot glue them together in just a few places with thin CA. Start by spot gluing the top, then the front and rear where the two halves just butt together. After the halves are joined, securely glue them along all seams with thin CA.

Note: Do not use CA accelerator on the ABS plastic as it may develop cracks and/or keep the paint from adhering.

5. Use your hobby knife or a MultiPro with a sanding drum to cut out the wheel openings.

Hint: Make the wheel openings wide as this will make installing the wheels and axles easier and cause less interference with the wheels upon landing and takeoff. You can see the size of the wheel openings in the following photo.

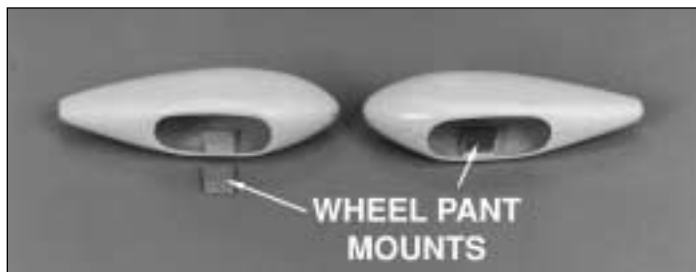

6. Use medium CA to glue the die-cut 1/8" plywood wheel pant mounts to the inside of each wheel pant.

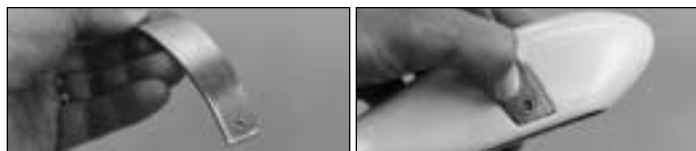

7. Use a metal file to chamfer the edges and corners of the aluminum landing gear so it will neatly fit in the recess of the wheel pant. Position the wheel pant on the aluminum landing gear, then use a felt-tip pen to accurately mark the location of the axle mounting hole.



8. Drill a 3/16" (11/64" or #18 for precision) hole in the wheel pant at the mark. Back up the wheel pant mount with a piece of plywood so you do not split it as the drill goes through.

☐☐ 9. Most 2-1/2" wheels are made to fit 5/32" axles but the 8-32 screws supplied in this kit for the axles require a larger hole. If the wheel does not roll freely on the 8-32 x 1-1/2" SHCS "axle" enlarge the wheel hub with an 11/64" (#18 for perfection) drill.

☐☐ 10. Test fit the wheel in the wheel pant using the following procedure:



A. Install an axle in a wheel, then thread an 8-32 nut on the axle about 1/8".



B. Insert the wheel in the pant with the end of the screw inserted in the plywood wheel pant mount and the head of the screw sticking out of the wheel pant.



C. Use a 9/64" hex wrench to screw the axle through the wheel and the wheel pant until the wheel goes all the way in and the axle goes through the pant mount.

Note: When you reinstall the wheel after the wheel pant has been painted, put masking tape on the bottom of the pant so the screw will not scratch it.

D. Adjust the tightness of the nut with hemostats or needle nose pliers.



☐☐ 11. Temporarily mount the wheel pant to the landing gear with another 8-32 nut on the axle.

☐ 12. Perform the same procedure to assemble and temporarily mount the other wheel pant to the landing gear.

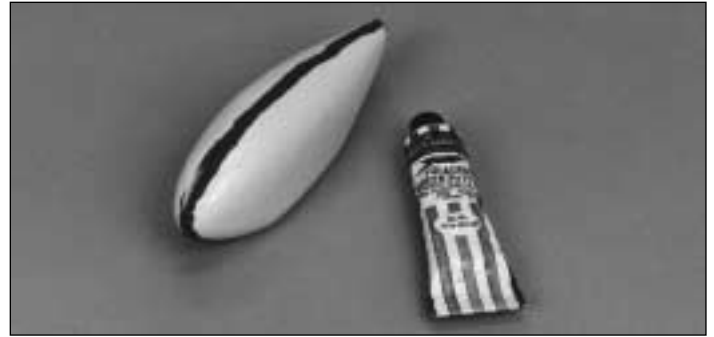

☐ 13. Before painting the wheel pants fill the seams with putty filler such as Squadron White Putty or resin filler such as Bondo. We use Bondo most of the time as it cures quickly and is easy to sand but usually it must be purchased in large quantities. Squadron putty works well but it takes overnight to dry and usually requires at least two applications because it shrinks as it dries.

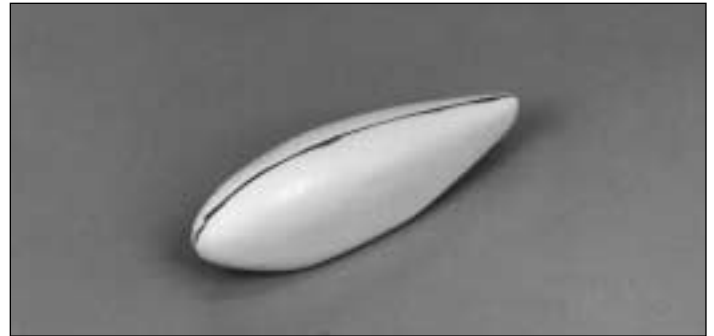

☐ 14. After the filler cures wet sand the wheel pants with 400-grit sandpaper to prepare them for primer.

Assemble the Cowl

☐ 1. The cowl is assembled just the same as the wheel pants. Cut the cowl along the cut lines, then use your bar sander to true all the edges. For now, the opening in the front of each cowl half only needs to be roughly cut out. Use coarse sandpaper to roughen the inside of all the overlapping areas so the glue will stick.

❑ 2. Tape the two pieces together, then wick a small amount of thin CA along the seams of the overlapping joints. After the CA has cured remove the tape and make sure you have thoroughly glued the two pieces together by inspecting the glue joints and adding thin CA if necessary.

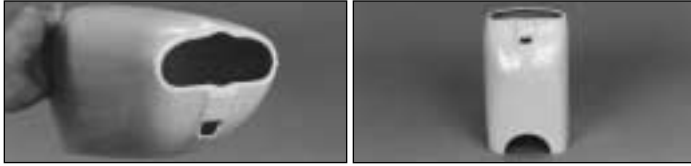

❑ 3. Use a sharp hobby knife or a MultiPro with a sanding drum to accurately cut the engine openings at the front of the cowl and the air exit at the rear of the cowl.

❑ 4. Use coarse sandpaper to thoroughly scuff the inside of the front of the cowl on both sides where there is no overlapping glue joint.

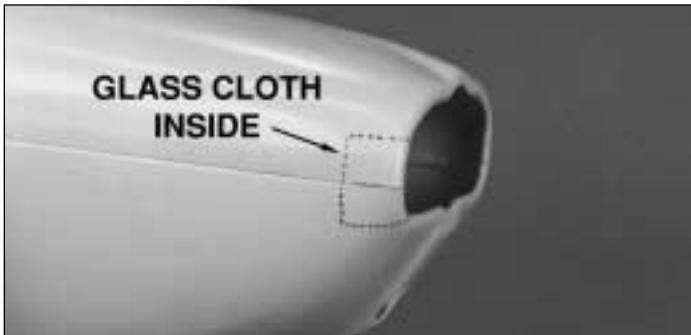

❑ 5. Use 30-minute epoxy to glue a 1" strip of glass cloth across the glue joint inside the front of the cowl on both sides.

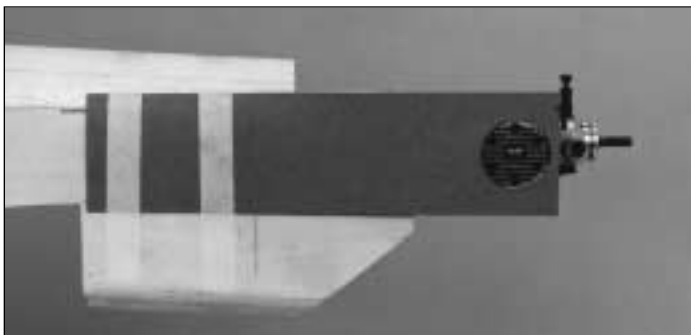

❑ 6. Use a piece of thin cardboard or plastic to make a template for the cutout in the cowl for the head of the engine. Tape the template to the fuselage side accurately indicating the position of the head.



❑ 7. Place the backplate of your spinner on the engine and measure the distance between the firewall and the backplate (it should be 4-3/4"). Remove the engine from the fuselage, then position the cowl on the fuselage so the forward edge is 1/8" aft of the measurement you just made. Use a ballpoint pen to lightly mark the location of the rear of the cowl on the fuselage top.



❑ 8. Align the cowl with the mark you made on the fuselage, then use a felt-tip pen to transfer the hole in the template onto the cowl.

Note: The circle you mark on the cowl may be slightly aft of the **actual position** of the head of the engine due to the upward sweep of the template when the the cowl is in position.

Hint: For the most accuracy, mount the engine to the fuselage and remove only the cylinder head. Position the cowl, then install the spinner backplate on the engine. Align the cowl with the spinner backplate (instead of the reference line you marked on the fuselage top), *then* transfer the hole in the template onto the cowl.

❑ 9. Remove the cowl and template, then remount the engine (or the cylinder head). Cut out the hole in the cowl, then test fit it to the fuselage (you may have to temporarily remove the needle valve so it does not interfere with the cowl.) Adjust the position and size of the hole as needed. The location of the hole determines the clearance between the front of the cowl and the back plate of the spinner.

Hint: Cut the hole in the cowl undersize at first so you can make adjustments to its position without having to oversize it.

❑ 10. Once you have made the hole in the cowl to clear the engine, place the cowl on the fuselage and fit the back plate of your spinner on the engine.



❑ 11. Align the cowl so there is approximately a 1/8" gap between the back plate of the spinner and the cowl, then use a ballpoint pen to mark the fuselage sides at the aft edge of the cowl.

❑ 12. Remove the cowl, then use medium CA to glue the four 5/16" x 3/4" x 7/8" hardwood **cowl mount blocks** to the fuselage sides in the location shown on the plan 1/4" in front of the lines you marked that indicate the sides of the cowl.

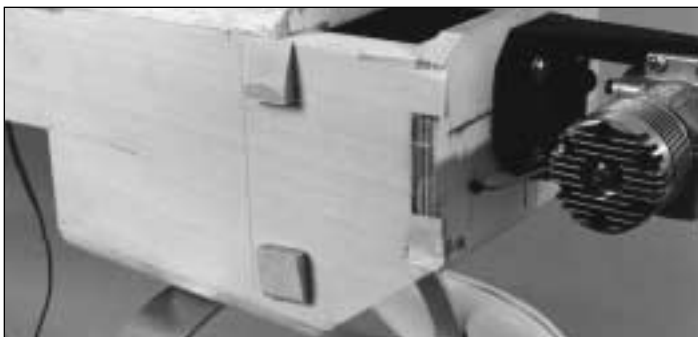

❑ 13. Shape the cowl mount blocks with your bar sander and 150-grit sandpaper so they match the shape of the cowl. Test fit the cowl and make adjustments to the blocks if necessary.



❑ 14. Position the cowl on the fuselage using the backplate of the spinner as a guide, then use a felt-tip pen to mark the cowl where to drill the holes for the cowl mounting screws. Drill a 1/16" hole through only the cowl at each mark. Accurately reposition the cowl and use a ballpoint pen to mark the location of the holes in the cowl on the cowl mount blocks.

❑ 15. Remove the cowl, then drill a 3/32" hole through each cowl mount block at the mark. Enlarge the 1/16" holes in the cowl with a 1/8" drill, then mount the cowl to the fuselage with the four 4-40 x 1/2" screws and #4 washers supplied with this kit.

❑ 16. Use the "template procedure" to determine the location of the hole in the cowl for the needle valve and muffler.

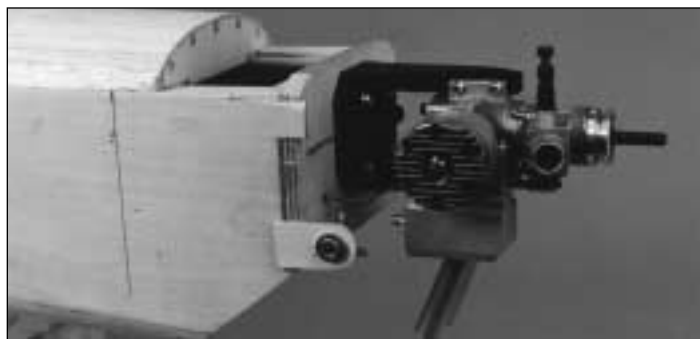

❑ 17. Mount a fueling system. On our prototype we made a mount for the Great Planes Easy Fueler from 1/8" leftover plywood, then securely glued it to the fuse side. Cut an access hole in the cowl for the Fueler.

❑ 18. Cut four 1" pieces of glass cloth, then use 30-minute epoxy to glue one piece to the inside of the cowl at each cowl mount hole. After the epoxy cures, re-drill the holes with a 1/8" drill bit.

❑ 19. Fill the seams or other imperfections in the cowl as described in the preceding Wheel Pants section, then **wet sand** the entire cowl with 400-grit sandpaper to prepare it for priming.

PREPARE THE MODEL FOR COVERING

❑ 1. If you've hooked up the pushrods to the servos before you covered the model, disconnect and remove all the control rods and remove the hinges and control horns from the ailerons, elevators and rudder. Remove the engine mount and any other hardware you may have installed.



❑ 2. Fill in the space between the turtle deck sheeting and aft end of the fuse sides on both sides of the fin with leftover balsa. Leave a space for the elevator joiner wire.



This step is optional but will enhance the scale appearance of your Extra 300.

- ❑ 3. Test fit the die-cut 1/8" plywood **fuselage side stringers** in the fuselage sides as shown on the plans, then use medium CA to glue them into position.
- ❑ 4. Most of the model should be rough-sanded by now with all the tabs and rough edges sanded even. Fill all dents, seams, low spots and notches with HobbyLite balsa colored filler.
- ❑ 5. After the filler has dried use progressively finer grades of sandpaper to even and smooth all the edges, seams and surfaces. Remove all balsa dust from the model with compressed air or a vacuum with a brush and a tack cloth.

COVERING

Covering Technique



Cover the model with **Top Flite MonoKote Film** using the recommended covering sequence that follows. Before you cover the fuselage, first apply 1/4" wide strips of MonoKote film in the corners of the stab and fuse and the fin and the fuse, then proceed to cover the fin and stab with pre-cut pieces that meet in the corners and overlap the 1/4" strips. **Never cut the covering on the stab and fin after it has been applied except around the leading and trailing edges at the tips.** Modelers who do this may cut through the covering and into the stab or fin. This will weaken the structure to a point where it may fail during flight. Since the tips of the elevators and stab are squared off it is easiest to cover the tips before you cover the tops and bottoms. Do the same for the fin, rudder and the wing. Some modelers drill a small hole in each stab rib and the

trailing edge of the stab to allow expanded gas to exit while heating the MonoKote film. This procedure keeps the covering from "ballooning" and allows you to securely bond it to the entire stab. The same thing can be done with the elevators, fin and rudder.

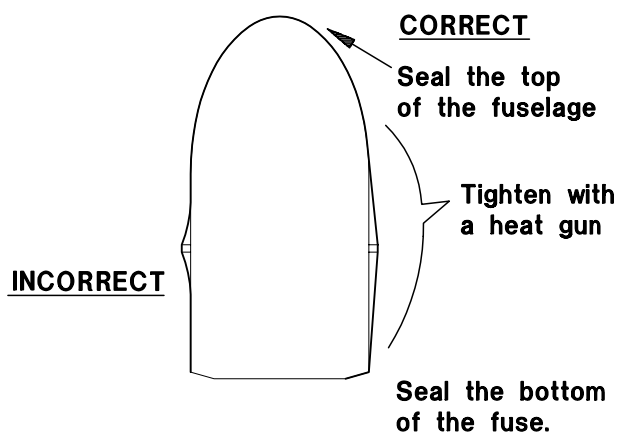

When you cover the fuselage, use your covering iron to seal only the **top of the turtle deck in the center** and the **bottom of the fuse**. Use your heat gun to shrink the rest of the covering on the fuselage, especially near the side stringers. This will provide a realistic, smooth transition from the turtle deck, over the side stringers, down to the fuse bottom.

Since the ailerons are long "strip" ailerons some modelers prefer to cover the top and bottom with one strip of MonoKote film by covering the bottom first, then wrapping it around the leading edge over the top.

Suggested Covering Sequence

Fuselage

1. 1/4" strips at fin and stab as described
2. Aft fuse bottom
3. Forward fuse bottom
4. Fuse right side up to the top center of the turtle deck
5. Fuse left side up to the top center of the turtle deck, overlapping by 1/8"
6. Forward fuse deck top
7. Fin tip, then stab tips
8. Stab bottom, then top
9. Fin right side, then left side
10. Elevator tips and root ends
11. Elevator bottoms, then tops
12. Rudder tip, then right side, then left side

Wing

1. Wing root spacers
2. Wing tips
3. Trailing edges of wing and inboard portion of tips and center leading edges
4. Belly pan bottom, then sides
5. Bottom of right, then left panel
6. Top of right, then left panel
7. Aileron tips, then bottom, then top of aileron

BALANCE THE MODEL Laterally

Do not confuse this procedure with "checking the C.G." which will be discussed later in the manual.

Now that the model is covered and nearly completed, this is the time to balance it laterally (side-to-side). Here's how:

1. With the wing level and attached to the model (and the engine and muffler installed), lift the model by the propeller shaft and the fin. This may require an assistant. Do this several times.
2. The wing that consistently drops indicates the heavy side. Balance the model by adding weight to the other wing tip.

An airplane that is laterally balanced will track better during aerobatic maneuvers.

PAINTING

After the model is covered, use fuelproof model paint, 30-minute epoxy thinned with alcohol or finishing resin to coat areas that may be exposed to raw fuel or exhaust residue. These are areas such as the firewall, front and back of the belly pan (DP and WBP-B), fuse openings for the wing (F-2B and FBP-A) and wing saddle doubler, fuel compartment hatch and the fuse top forward of the sheeting.

Top Flite LustreKote fuelproof paint is recommended for painting all the ABS plastic parts and the aluminum landing gear. The wheel pants should be removed from the landing gear for painting. Use a file to round the corners of the aluminum landing gear before you paint it. At least one coat of LustreKote primer is highly recommended to fill all the small scratches left from sanding as well as small pin holes in the Bondo filler. Wet sand between coats with 400-grit sandpaper and apply a second coat of primer if necessary.

Before painting the canopy use scissors or a hobby knife to trim it along the molded cut lines, then true the edges with your bar sander and 220-grit sandpaper. Use 400-grit sandpaper to scuff the frame portion of the canopy so the paint will stick. We recommend you paint the canopy frame with Pactra Formula-U or Chevron Perfect Paint. Use masking tape to cover the portion of the canopy that is not to be painted. If you are not sure that the paint is compatible with the clear canopy, test the paint on a leftover piece of canopy material.

For painting the pilot we have discovered that acrylic water base paints such as the types found at craft stores work great. The acrylic paints look realistic on the pilot because they are not glossy and best of all, they clean-up with water.

Paint the cockpit interior using your own imagination (or scale documentation) as a guide. We painted the back rest (former F-3), the instrument panel and the 1/4" x 1/4" cockpit sides with flat black brush-on paint, then covered the cockpit floor with 600-grit sandpaper glued in place with 3M 77 spray adhesive.

FINAL HOOKUPS & CHECKS

Join the Control Surfaces

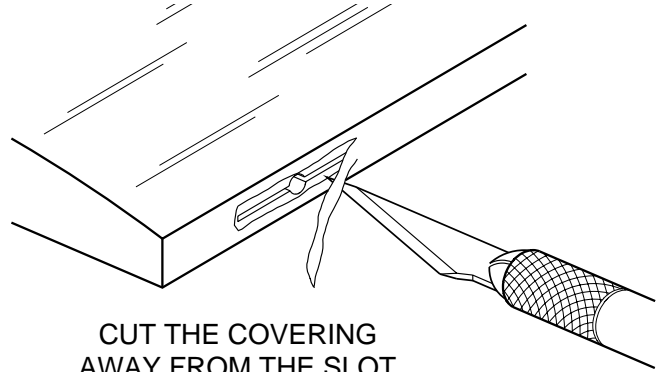

1. Start with the elevators and stab. Cut the covering from the hinge slots—don't just *slit* the covering but remove a small strip the size of the hinge slot.

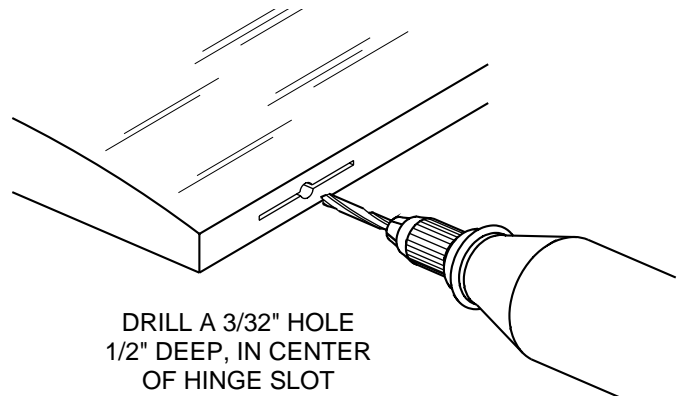

2. Drill a 3/32" hole 1/2" deep in the center of each hinge slot. A high speed Dremel Tool works best for this. If you use a regular drill, clean out the hinge slots with your #11 blade.
3. Use coarse sandpaper to scuff the elevator joiner wire, the tail wheel wire and the aileron torque rods so the glue will stick. Clean the aileron torque rod arms, the elevator joiner wire and the tail wheel wire with rubbing alcohol to remove residue that may keep the glue from sticking. Don't wipe away the marks you made earlier on the elevator joiner wire (so the elevators remain parallel and flat).
4. Fit the elevator joiner wire through the slot in the fuse at the trailing edge of the stab. Make sure the joiner wire will be in the same orientation it was when the elevators were joined so they are flat and parallel.

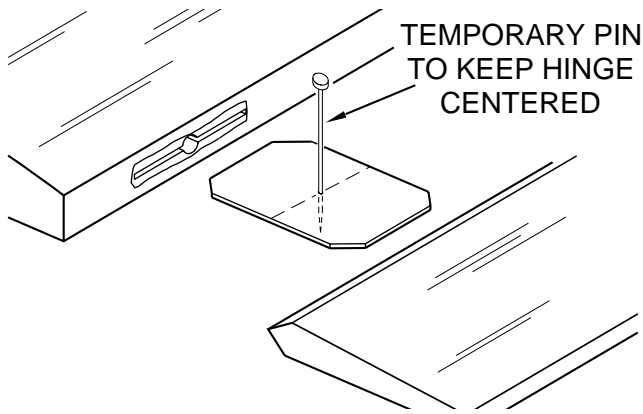

❑ 5. Without using any glue, fit the hinges in the elevators or stab, then fill the holes in the elevators for the joiner wire with 30-minute epoxy. Join the elevators to the stab and joiner but **do not glue the hinges yet**. As you join the elevators to the stab, confirm that the hinges are equally inserted in the elevators and the stab. You may insert a small pin in the center of the hinges to keep them centered.

❑ 6. Remove excess epoxy that squeezes out of the elevators with a cloth dampened with alcohol. Close the hinge gap to 1/32" or less—it is best to have a *slight* gap to avoid inadvertently gluing the control surfaces together. Remove the pins if you have used them to center the hinges.

ASSEMBLE, THEN APPLY 6 DROPS OF THIN CA TO CENTER OF HINGE, ON BOTH SIDES

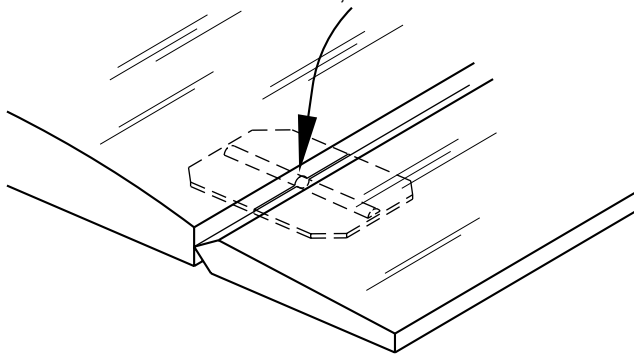

THE CA WICKS ALONG THE "TUNNELS" TO THE ENTIRE HINGE SURFACE

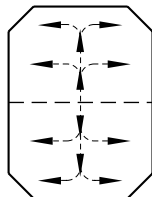

❑ 7. Add 6 drops of thin CA to the center of all the hinges on **both the top and the bottom**.

Do not use accelerator on any of the hinges. Do not glue the hinges with anything but thin CA and do not attempt to glue one half of the hinge at a time with medium or thick CA. They will not be properly secured and the controls could separate while the model is in flight.

❑ 8. Join the rudder to the fin with the hinges and use 30-minute epoxy to simultaneously glue the tail gear wire in the rudder and the tail gear bearing in the fuse. **Do not glue the nylon bearing to the rudder.** Glue the hinges in position with thin CA.

Hint: Apply a little petroleum jelly to the tail gear wire where it passes through the nylon bearing. This will prevent the wire from being glued into the bearing.

❑ 9. Prepare the hinge slots in the ailerons the same way you did for the tail surfaces.

❑ 10. Use a toothpick to pack the torque rod holes in the ailerons with 30-minute epoxy, then join the ailerons to the wing with the hinges. Glue the hinges with thin CA. Wipe away the epoxy that is squeezed out of the ailerons with a paper towel and alcohol.

❑ 11. If you have not yet installed and connected the control horns and elevator, rudder and aileron pushrods return to step 6 on page 32 for instructions on how to do so.

Install the Hardware

❑ 1. Assemble the fuel tank per the manufacturers instructions. Connect approximately 1' of fuel tubing to the fuel pick-up fitting on the tank and 1' of fuel tubing to the pressure fitting on the tank. Slide the tank through the opening in F-2B as you route the lines through the holes you drilled in the firewall (you may have to remove the servos to install the fuel tank). Secure the tank to the tank floor by hooking #64 rubber bands to the wood rails you glued to the bottom of the tank floor.

❑ 2. Install a 1" tail wheel with a 3/32" wheel collar.

❑ 3. Install the wheels in the wheel pants (don't forget the masking tape so the screw doesn't scratch the paint), then mount the wheel pants to the landing gear. Secure the 8-32 nuts with a drop of thread lock.

❑ 4. Mount the landing gear to the fuselage with the 8-32 x 3/4" SHCS and #8 washers.

❑ 5. Install the elevator, rudder and throttle pushrods, then install the control horns and hook them up the same way you did earlier.

❑ 6. Wrap the receiver and battery pack in at least 1/4" of foam rubber, then fit them ahead of former F-2B in the location shown on the plan. Pack extra foam in the compartment to keep the receiver and battery pack from dislodging during aerobatics or a rough landing.

❑ 7. Mount the receiver switch in a convenient location that will not interfere with the servos and pushrods inside the fuselage.

❑ 8. Route the receiver antenna. On our prototype we drilled a small hole in the bottom of the fuse aft of the wing bolt plate and inserted a piece of rubber tubing to route the antenna through (fuel tubing or neoprene retractable landing gear air tubing works well). Make a strain relief from a cut-off servo arm and place it on the antenna near the receiver as shown on the plan, then route the antenna through the tubing. Make a hook out of another cut-off servo arm and loop the end of the antenna to it. Connect the other end of the cut-off servo arm to a rubber band and loop it around the tail wheel wire.

❑ 9. Apply 1/16" seating tape on the wing saddle of the fuselage if you choose.

❑ 10. Prepare the engine compartment for installing the cowl by connecting the fuel lines, installing the fueling valve, mounting the muffler and connecting the throttle pushrod. Install the cowl, then mount the spinner back plate, prop, prop washer and prop nut. Install the spinner.

❑ 4. Before you permanently glue the canopy to the fuselage, securely glue your pilot in place. For the most security, in addition to glue, screw the base of the pilot to the cockpit floor with two #4 or #6 sheet metal screws from the underside of the cockpit floor. Place the instrument panel decal on the instrument panel.

❑ 5. Reposition the canopy on the fuselage and confirm that it covers the exposed wood. Glue the canopy to the fuselage using rubber bands or masking tape to hold it in position until the glue dries. We recommend a glue specifically formulated for gluing on canopies such as Pacer "Formula 560" canopy glue. Formula 560 is like regular white glue (aliphatic resin) in that it dries clear and cleans-up with water but sticks extremely well to butyrate and dries overnight (to allow for accurate positioning).

Set the Control Throws

IMPORTANT

Do not exceed the elevator throws provided. The Extra 300 requires very little elevator throw to perform even the most aggressive aerobatics. Exceeding the recommended throws may result in a model that is very difficult to control.

Attach the Canopy



❑ 1. Place the canopy on the fuselage in the location shown on the plan, then temporarily hold it in position with tape or rubber bands.

❑ 2. Use a felt-tip pen to **accurately** trace the canopy outline onto the MonoKote film covering. Remove the canopy.



❑ 3. Use a sharp #11 blade to **carefully** cut the covering about 1/32" inside of the line you marked **without cutting into the balsa**. Wipe away the ink line with a paper towel lightly dampened with alcohol.

4-CHANNEL RADIO SETUP (STANDARD MODE 2)

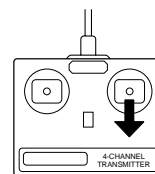

ELEVATOR MOVES UP

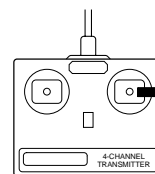

RIGHT AILERON MOVES UP
LEFT AILERON MOVES DOWN

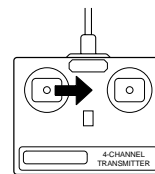

RUDDER MOVES RIGHT

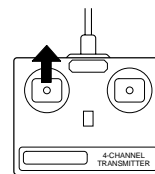

CARBURETOR WIDE OPEN

The throws are measured at the **widest part** of the elevators, rudder and ailerons. Adjust the position of the pushrods at the control/servo horns to control the amount of throw. You may also use the ATV's if your transmitter has them but the mechanical linkages should still be set so the ATV's are near 100% for the best servo resolution (smoothest, most proportional movement).

Do not exceed the elevator throws provided.

We recommend the following control surface throws:

	High Rate	Low Rate
ELEVATOR:	5/16" up 3/8" down	1/4" up 5/16" down
RUDDER:	2-1/8" right 2-1/8" left	1-1/2" right 1-1/2" left
AILERONS:	3/8" up 3/8" down	1/4" up 1/4" down

NOTE: If your radio does not have dual rates, then set the control surfaces to move **between** the high rate and low rate throws.

NOTE: The balance and control throws for the Extra 300 have been extensively tested. This chart indicates the settings at which the Extra 300 flies best. Please set up your model to the specifications listed above. If, after you become comfortable with your Extra 300, you would like to adjust the throws to suit your tastes, that's fine. Too much throw can force the plane into a stall or snap roll, so remember, "more is not better."

Balance Your Model

NOTE: This section is VERY important and must NOT be omitted! A model that is not properly balanced will be unstable and possibly unflyable.

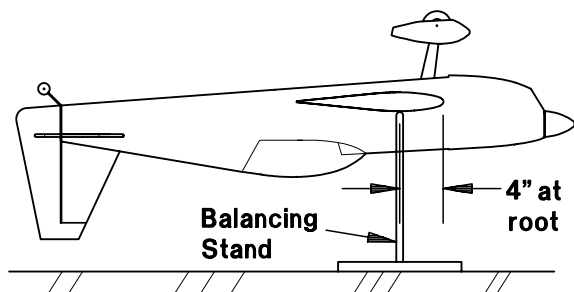

1. Accurately mark the balance point on the **top** of the wing on both sides of the fuselage. Use thin strips of tape or a felt-tip pen to make the marks. The balance point (**CG**) is located **4" back from the leading edge** and next to the fuse sides as shown in the sketch and on the fuselage plan.

Hint: Reference the full size fuse plan to help you locate the proper balance point. This is the balance point at which your

model should balance for your first flights. After initial trim flights and when you become more acquainted with your Extra 300, you may wish to experiment by shifting the balance up to **1/4" forward or back** to change the flying characteristics. Moving the balance **forward** may improve the smoothness and stability but the model may then require more speed for takeoff and may become more difficult to slow for landing. Moving the balance **aft** makes the model **more agile** with a lighter, snappier "feel" and often improves knife-edge capabilities. In any case, **please start at the location we recommend and do not at any time balance your model outside the recommended range.**

2. With the wing attached to the fuselage, all parts of the model installed (ready to fly) and an **empty** fuel tank, hold the model upsidedown with the stabilizer level.

3. Lift the model at the balance point. If the **tail** drops when you lift, the model is "tail heavy" and you must add weight* to the nose to balance the model. If the **nose** drops, it is "nose heavy" and you must add weight* to the tail to balance the model.

NOTE: Nose weight may be easily installed by using a "spinner weight" or gluing lead weights to the firewall. Tail weight may be added by using Great Planes (GPMQ4485) "stick-on" lead weights. Later if the balance is O.K., you can open the fuse bottom and glue the weights in permanently.

* If possible, first attempt to balance the model by changing the position of the receiver battery and receiver. If you are unable to obtain good balance by doing so, then it will be necessary to add weight to the nose or tail to achieve the proper balance point.

PREFLIGHT

At this time check all connections including servo arm screws, faslinks, clevises and servo cords. Make sure you have installed the **nylon retainer** on the Screw-Lock Pushrod Connector on the throttle pushrod at the servo arm and the **silicone retainers** on all the clevises.

Charge the Batteries

Follow the battery charging procedures in your radio instruction manual. You should **always** charge your transmitter and receiver batteries the night before you go flying and at other times as recommended by the radio manufacturer.

Balance the Propeller

Carefully balance your propellers before flying. An unbalanced prop is the single most significant cause of vibration. Not only may engine mounting screws vibrate out, possibly with disastrous effect, but vibration may also damage your radio receiver and battery. Vibration may cause your fuel to foam, which will, in turn, cause your engine to run lean or quit.

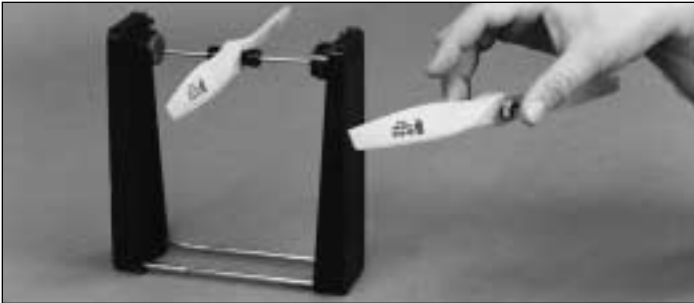

We use a **Top Flite Precision Magnetic Prop Balancer** (TOPQ5700) in the workshop and keep a **Great Planes Fingertip Balancer** (GPMQ5000) in our flight box.

Find a Safe Place to Fly

Since you have chosen the Extra 300 we assume that you are an experienced modeler. Therefore, you should already know about AMA chartered flying fields and other safe places to fly. If, for some reason you are a relatively inexperienced modeler and have not been informed, we strongly suggest that the best place to fly is an AMA chartered club field. Ask the AMA or your local hobby shop dealer if there is a club in your area and join. Club fields are set up for R/C flying and that makes your outing safer and more enjoyable. The AMA address and telephone number is in the front of this manual. If a club and flying site are not available, find a large, grassy area at least 6 miles away from houses, buildings and streets and any other R/C radio operation like R/C boats and R/C cars. A schoolyard may look inviting but is too close to people, power lines and possible radio interference.

Ground Check the Model

Inspect your radio installation and confirm that all the control surfaces respond correctly to transmitter inputs. The engine operation must also be checked by confirming that the engine idles reliably and transitions smoothly and rapidly to full power and maintains full power indefinitely. The engine must be "broken-in" on the ground by running it for at least two tanks of fuel. **Follow the engine manufacturer's recommendations for break-in.** Make sure all screws remain tight, that the hinges are secure and that the prop is on tight.

Range Check Your Radio

Whenever you go to the flying field, check the operational range of the radio before the first flight of the day. First, make sure no one else is on your frequency (channel). With your transmitter antenna collapsed and the receiver and transmitter on, you should be able to walk at least 100 feet away from the model and still have control. While you work the controls have a helper stand by your model and tell you what the control surfaces are doing. Repeat this test **with the engine running** at various speeds with a helper holding the model. If the control surfaces are not always responding correctly, **do not fly!** Find and correct the problem first. Look for loose servo connections or corrosion, loose bolts that may cause vibration, a defective on/off switch, low battery voltage or a defective cell, a damaged receiver antenna, or a receiver crystal that may have been damaged from a previous crash.

Engine Safety Precautions

NOTE: Failure to follow these safety precautions may result in severe injury to yourself and others.

Keep all engine fuel in a safe place, away from high heat, sparks or flames as fuel is very flammable. Do not smoke near the engine or fuel; and remember that the engine exhaust gives off a great deal of deadly carbon monoxide. **Do not run the engine in a closed room or garage.**

Get help from an experienced pilot when learning to operate engines.

Use safety glasses when starting or running engines.

Do not run the engine in an area of loose gravel or sand; the propeller may throw such material in your face or eyes.

Keep your face and body as well as all spectators away from the plane of rotation of the propeller as you start and run the engine.

Keep these items away from the prop: loose clothing, shirt sleeves, ties, scarfs, long hair or loose objects such as pencils, screw drivers that may fall out of shirt or jacket pockets into the prop.

Use a "chicken stick" or electric starter; follow instructions supplied with the starter or stick. Make certain the glow plug clip or connector is secure so that it will not pop off or otherwise get into the running propeller.

Make all engine adjustments from **behind** the rotating propeller.

The engine gets hot! Do not touch it during or after operation. Make sure fuel lines are in good condition so fuel will not leak onto a hot engine causing a fire.

To stop the engine, cut off the fuel supply by closing off the fuel line or follow the engine manufacturer's recommendations. Do not use hands, fingers or any other body part to try to stop the engine. Do not throw anything into the propeller of a running engine.

AMA SAFETY CODE (excerpt)

Read and abide by the following Academy of Model Aeronautics Official Safety Code:

General

1. I will not fly my model aircraft in sanctioned events, air shows, or model flying demonstrations until it has been proven to be airworthy by having been previously successfully flight tested.
2. I will not fly my model aircraft higher than approximately 400 feet within 3 miles of an airport without notifying the airport operator. I will give right of way to and avoid flying in the proximity of full scale aircraft. Where necessary an observer shall be used to supervise flying to avoid having models fly in the proximity of full scale aircraft.
3. Where established, I will abide by the safety rules for the flying site I use and I will not willfully and deliberately fly my models in a careless, reckless and/or dangerous manner.
7. I will not fly my model unless it is identified with my name and address or AMA number, on or in the model.
9. I will not operate models with pyrotechnics (any device that explodes, burns, or propels a projectile of any kind)

Radio Control

1. I will have completed a successful radio equipment ground check before the first flight of a new or repaired model.
2. I will not fly my model aircraft in the presence of spectators until I become a qualified flier, unless assisted by an experienced helper.
3. I will perform my initial turn after takeoff away from the pit or spectator areas and I will not thereafter fly over pit or spectator areas, unless beyond my control.
4. I will operate my model using only radio control frequencies currently allowed by the Federal Communications Commission.

FLYING

CAUTION (THIS APPLIES TO ALL R/C AIRPLANES): If, while flying, you notice any unusual sounds, such as a low-pitched “buzz”, this may indicate control surface “flutter”. Because flutter can quickly destroy components of your airplane, any time you detect flutter you must **immediately** cut the throttle and land the airplane! Check all servo grommets for deterioration (this may indicate which surface fluttered) and make sure all pushrod linkages are slop-free. If it fluttered once, it will probably flutter again under similar circumstances unless you can eliminate the slop or flexing in the linkages. Here are some things which can result in flutter: Excessive hinge gap; Not mounting control horns solidly; Sloppy fit of clevis pin in horn; Elasticity present in flexible plastic pushrods; Side-play of pushrod in guide tube caused by tight bends; Sloppy fit of Z-bend in servo arm; Insufficient glue used when gluing in the elevator joiner wire or aileron torque rod; Excessive flexing of aileron, caused by using too soft balsa; Excessive “play” or “backlash” in servo gears; and Insecure servo mounting.

The Great Planes Extra 300 is a great flying semi-scale sport model that flies smoothly and predictably, yet is highly aerobatic. The Extra does not, however, possess the self-recovery characteristics of a primary R/C trainer and should only be flown by experienced RC pilots. This plane is fully capable of performing a full range of aerobatics – from simple loops and rolls to impressive Lomcevaks. The Extra 300 is limited only by your abilities and imagination. Have fun!

Takeoff

Takeoff on “high” rates if you have dual rates on your transmitter – especially if you are taking off in a crosswind. For all models it is good practice to gain as much speed as the length of the runway will permit before lifting off. This will give you a safety margin in case the engine quits. When you initially advance the throttle and the tail begins to lift, the Extra will begin to turn to the left (due to the torque of the engine—a characteristic of all taildraggers). Be prepared for this by applying sufficient right rudder to keep the Extra running straight down the middle of the runway. The left turning tendency will decrease as the plane picks up speed. Be sure to allow the tail to rise off the ground before lifting the model into the air. Depending on the surface you are taking off from, you will need to apply little or no up elevator until flying speed is reached. Don't hold the tail on the ground with too much up elevator, as the Extra will become airborne prematurely and may stall. When the plane has gained enough flying speed to safely lift off, gradually and smoothly apply up elevator and allow the model to climb at a shallow angle (do not yank the model off the ground into a steep climb!).

Flight

We recommend that you take it easy with your Extra 300 for the first several flights, gradually “getting acquainted” with this great sport model as your engine gets fully broken in. If you feel as though you have your hands full, keep this in mind: **pull back on the throttle stick to slow the model down.** This will make everything happen a little slower and allow yourself time to think and react. Add and practice one maneuver at a time, learning how the Extra behaves in each. For smooth flying and normal maneuvers, use the low rate settings as listed on page 41. High rate elevator may be required for crisp snap rolls and spins. For good knife-edge performance forward flight speed is the key.

Sometime well before it's time to land you should climb your Extra to a safe altitude and cut the throttle to an idle and check out the model's low speed characteristics. Do this a few times so you know what to expect upon landing.

Landing

When it's time to land, fly a normal landing pattern and approach. Keep a few clicks of power on until you are over the runway threshold. For your first few landings, plan to land slightly faster than stall speed and on the main wheels, as this is the easiest way to land your Extra. Later, with a little practice you will find you can make slow 3-point landings.

Have a ball! But always remember to think about your next move and plan each maneuver before you do it. Impulsively “jamming the sticks” without any thought is what gets most fliers in trouble rather than lack of flying skill. Happy Landings!

APPENDIX

FLIGHT TRIMMING

A model is not a static object. Unlike a car, which can only hunt left or right on the road (technically, a car does yaw in corners and pitches when the brakes are applied), a plane moves through that fluid we call air in all directions simultaneously. The plane may look like it's going forward, but it could also be yawing slightly, slipping a little and simultaneously climbing or diving a bit! The controls interact. Yaw can be a rudder problem, a lateral balance problem or an aileron rigging problem. We must make many flights, with minor changes between each, to isolate and finally correct the problem.

The chart accompanying this article is intended to serve as a handy field reference when trimming your model. Laminate it in plastic and keep it in your flight box. You just might have need to consult it at the next contest! The chart is somewhat self-explanatory, but we will briefly run through the salient points.

First, we are assuming that the model has been C.G. balanced according to the manufacturer's directions. There's nothing sacred about that spot — frankly, it only reflects the balance point where a prototype model handled the way the guy who designed it thought it should. If your model's wing has a degree more or less of incidence, then the whole balance formula is incorrect for you. But, it's a good ballpark place to start.

The second assumption is that the model has been balanced laterally. Wrap a strong string or monofilament around the prop shaft behind the spinner, then tie the other end to the tail wheel or to a screw driven into the bottom of the aft fuse. Make the string into a bridle harness and suspend the entire model inverted (yes, with the wing on!). If the right wing always drops, sink some screws or lead into the left wing tip, etc. You may be surprised to find out how much lead is needed.

At this point the model is statically trimmed. It's only a starting point, so don't be surprised if you wind up changing it all. One other critical feature is that the ailerons must have their hinge gap sealed. If shoving some Scotch tape or MonoKote into the hinge gap to prevent the air from slipping from the top of the wing to the bottom and vice-versa, bothers you, then don't do it.

To achieve the maximum lateral trim on the model, the hinge gap on the ailerons should be sealed. The easiest way to do this is to disconnect the aileron linkages and fold the ailerons as far over the top of the wing as possible (assuming they are top or center hinged). Apply a strip of clear tape along the joint line. When the aileron is returned to neutral, the tape will be invisible and the gap will be effectively sealed. Depending on how big the ailerons are, and how large a gaping gap you normally leave when you install hinges, you could experience a 20 percent increase in aileron control response just by this simple measure.

Your first flights should be to ascertain control centering and control feel. Does the elevator always come back to neutral after a 180-degree turn or Split-S? Do the ailerons tend to hunt a little after a rolling maneuver? Put the plane through its paces. Control centering is either a mechanical thing (binding servos, stiff linkages, etc.), an electronic thing (bad servo resolution or dead-band in the radio system), or C.G. (aft Center of Gravity will make the plane wander a bit). The last possibility will be obvious, but don't continue the testing until you have isolated the problem and corrected it.

Let's get down to the task of trimming the model. Use the tachometer every time you start the engine, to insure consistent results. These trim flights must be done in calm weather. Any wind will only make the model weathervane. Each “maneuver” on the list assumes that you will enter it dead straight-and-level. The wings must be perfectly flat, or else the maneuver will not be correct and you'll get a wrong interpretation. That's where your observer comes in. Instruct him to be especially watchful of the wings as you enter the maneuvers.

Do all maneuvers at full throttle. The only deviation from this is if the plane will be routinely flown through maneuvers at a different power setting.

Let's commence with the "engine thrust angle" on the chart. Note that the observations you make can also be caused by the C.G., so be prepared to change both to see which gives the desired result. Set up a straight-and-level pass. The model should be almost hands-off. Without touching any other control on the transmitter, suddenly chop the throttle. Did the nose drop? When you add power again, did the nose pitch up a bit? If so, you need some downthrust, or nose weight. When the thrust is correct, the model should continue along the same flight path for at least a dozen plane lengths before gravity starts to naturally bring it down.

Do each maneuver several times, to make sure that you are getting a proper diagnosis. Often, a gust, an accidental nudge on the controls, or just a poor maneuver entry can mislead you. The thrust adjustments are a real pain to make. On most models, it means taking the engine out, adding shims, then reassembling the whole thing. Don't take shortcuts. Don't try to proceed with the other trim adjustments until you have the thrust line and/or C.G. correct. They are the basis upon which all other trim setting are made.

Also, while you have landed, take the time to crank the clevises until the transmitter trims are at neutral. Don't leave the airplane so that the transmitter has some odd-ball combination of trim settings. One bump of the transmitter and you have lost everything. The trim must be repeatable, and the only sure way to do this is to always start with the transmitter control trims at the middle.

The next maneuver is somewhat more tricky than it looks. To verify the C.G., we roll the model up to a 45-degree bank, then take our hands off the controls. The model should go a reasonable distance with the fuse at an even keel. If the nose pitches down, remove some nose weight, and the opposite if the nose pitches up. The trick is to use only the ailerons to get the model up at a 45-degree bank. We almost automatically start feeding in elevator, but that's a no-no. Do the bank in both directions, just to make sure that you are getting an accurate reading of the longitudinal balance.

We now want to test the correct alignment of both sides of the elevator (even if they aren't split, like a Pattern ship's, they can still be warped or twisted). Yaw and lateral balance will also come into play here, so be patient and eliminate the variables, one-by-one. The maneuver is a simple loop, but it must be entered with the wings perfectly level. Position the maneuver so that your assistant can observe it end-on. Always loop into the wind. Do several loops, and see if the same symptom persists. Note if the model loses heading on the front or back side of the loop. If you lose it on the way up, it's probably an aileron problem, while a loss of heading on the way back down is most likely a rudder situation. After you get the inside loops going correctly, do the same maneuver to the outside, entering from an inverted position. Before you make too many dramatic changes, glance at the remainder of the chart and note the myriad combination of things we can do just with the ailerons. Each change you make will affect all other variables!

Note that the Yaw test is the same looping sequences. Here, however, we are altering rudder and ailerons, instead of the elevator halves. We must repeat that many airplanes just will not achieve adequate lateral trim without sealing the hinge gaps shut. The larger you make the loops (to a point), the more discernable the errors will be.

The Lateral Balance test has us pulling those loops very tightly. Actually, we prefer the Hammerhead as a better test for a heavy wing. Pull straight up into a vertical and watch which wing drops. A true vertical is hard to do, so make sure that your assistant is observing from another vantage point. Note that the engine torque will affect the vertical fall off, as will rudder errors. Even though we balance the wing statically before leaving for the field, we are now trimming it dynamically.

The Aileron Coupling (or rigging) is also tested by doing Hammerheads. This time, however, we want to observe the side view of the model. Does the plane want to tuck under a bit? If so, then try trimming the ailerons down a small bit, so that they will act as flaps. If the model tends to want to go over into a loop, then rig both ailerons up a few turns on the clevises. Note that drooping the ailerons will tend to cancel any washout you have in the wing. On some models, the lack of washout can lead to some nasty characteristics at low speeds.

The effects noted with the Aileron Coupling tests can also be caused by an improperly set wing incidence. The better test for this is knife-edge flight . . . If the model tends to pull upward, i.e., it swings toward a nose up direction, then reduce the wing incidence. If the model tries to go off heading toward the bottom side of the plane, then increase incidence.

Again, we reiterate that all of these controls are interactive. When you change the wing incidence, it will influence the way the elevator trim is at a given C.G. Re-trimming the wing will also change the rigging on the ailerons, in effect, and they may have to be readjusted accordingly.

The whole process isn't hard. As a matter of fact it's rather fun — but very time consuming. It's amazing what you will learn about why a plane flies the way it does, and you'll be a better pilot for it. One thing we almost guarantee, is that your planes will be more reliable and predictable when they are properly trimmed out. They will fly more efficiently, and be less prone to doing radical and surprising things. Your contest scores should improve, too.

We wish to acknowledge the Orlando, Florida, club newsletter, from which the basics of the chart presented here were gleaned.

Reprinted in part by Great Planes Model Manufacturing Company, courtesy of Scale R/C Modeler magazine, Pat Potega, Editor, August 1983 issue.

<u>TRIM FEATURE</u>	<u>MANEUVERS</u>	<u>OBSERVATIONS</u>	<u>CORRECTIONS</u>
CONTROL CENTERING	Fly general circles and random maneuvers.	Try for hands off straight and level flight.	Readjust linkages so that Tx trims are centered.
CONTROL THROWS	Random maneuvers	A. Too sensitive, jerky controls. B. Not sufficient control.	If A, change linkages to reduce throws. If B, increase throws.
ENGINE THRUST ANGLE ¹	From straight flight, chop throttle quickly.	A. Aircraft continues level path for short distance. B. Plane pitches nose up. C. Plane pitches nose down.	If A, trim is okay. If B, decrease downthrust. If C, increase downthrust.
CENTER OF GRAVITY LONGITUDINAL BALANCE	From level flight roll to 45-degree bank and neutralize controls.	A. Continues in bank for moderate distance. B. Nose pitches up. C. Nose drops.	If A, trim is good. If B, add nose weight. If C, remove nose weight.
YAW ²	Into wind, do open loops, using only elevator. Repeat tests doing outside loops from inverted entry.	A. Wings are level throughout. B. Yaws to right in both inside and outside loops. C. Yaws to left in both inside and outside loops. D. Yaws right on insides, and left on outside loops. E. Yaws left in insides, and right on outside loops.	If A, trim is correct. If B, add left rudder trim. If C, add right rudder trim. If D, add left aileron trim. If E, add right aileron trim.
LATERAL BALANCE	Into wind, do tight inside loops.	A. Wings are level and plane falls to either side randomly. B. Falls off to left in loops. Worsens as loops tighten. C. Falls off to right in loops. Worsens as loops tighten.	If A, trim is correct. If B, add weight to right wing tip. If C, add weight to left wing tip.
AILERON RIGGING	With wings level, pull to vertical climb and neutralize controls.	A. Climb continues along same path. B. Nose tends to go to inside loop. C. Nose tends to go to outside loop.	If A, trim is correct. If B, raise both ailerons very slightly. If C, lower both ailerons very slightly.

1. Engine thrust angle and C.G. interact. Check both.

2. Yaw and lateral balance produce similar symptoms. Note that fin may be crooked. Right and left references are from the plane's vantage point.

TWO VIEW DRAWING

Use copies of this page to plan your trim scheme.

