

Super Tote™

Assembly Manual



CARL GOLDBERG PRODUCTS LTD.™

P.O. Box 818, Oakwood, GA 30566 • 678-450-0085 • Fax: 770-532-2163 • www.carlgoldbergproducts.com

WOOD PARTS IDENTIFICATION

If you should have any questions about the parts in this kit, please include the part number(s) listed below when referring to part(s) in question.

If instead of painting, you intend to apply a clear finish, the Tote should be assembled with this final appearance in mind. So, during assembly, select each part for its best looking side and position it to form the exterior surface of the Tote.

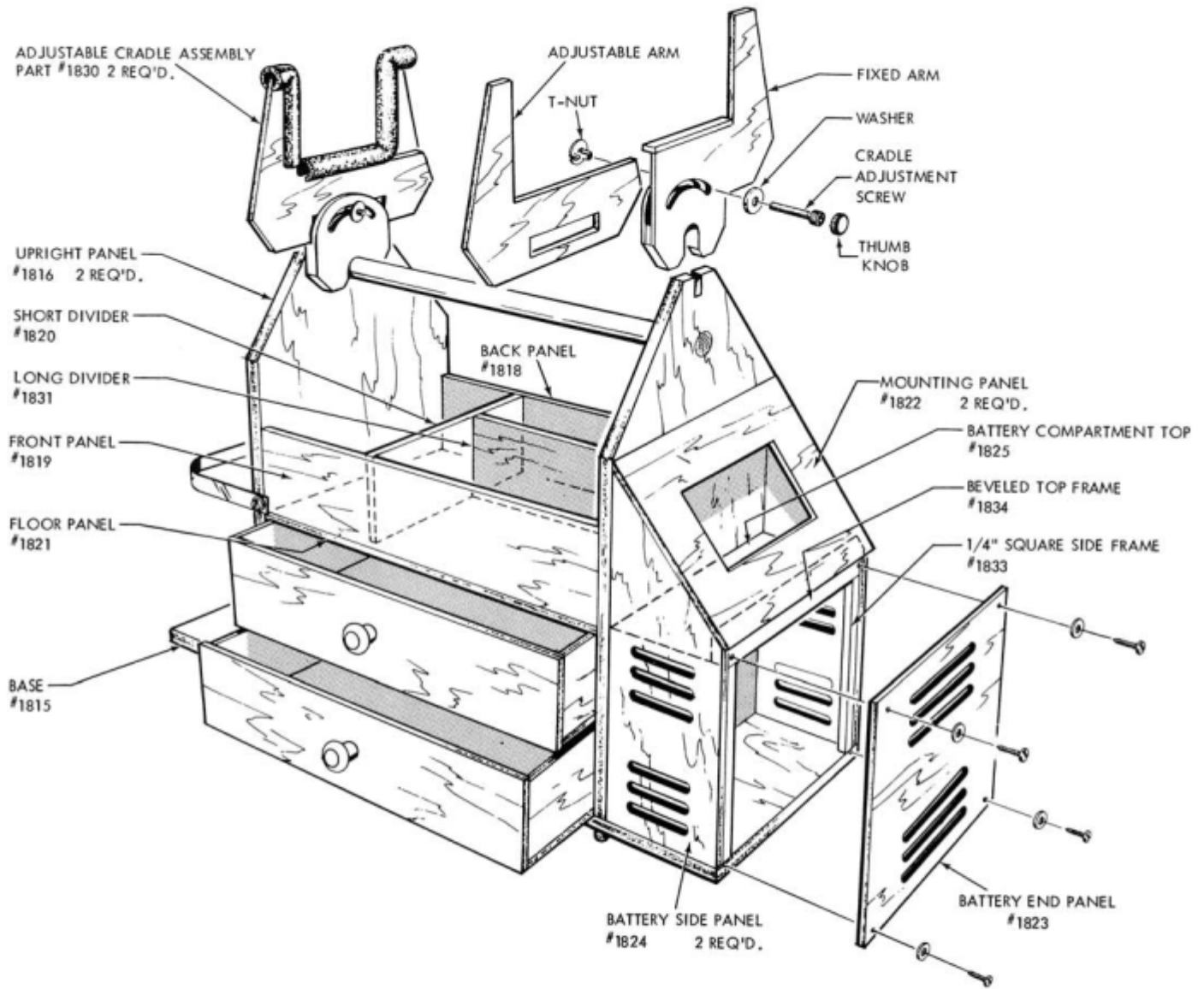

THE DIAGRAMS BELOW SHOW HOW TO IDENTIFY SIMILAR LOOKING PARTS.

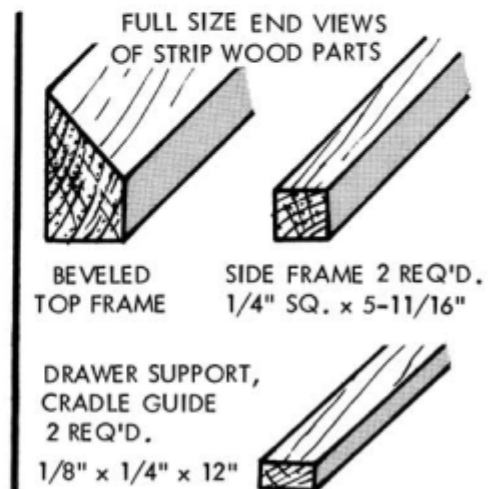
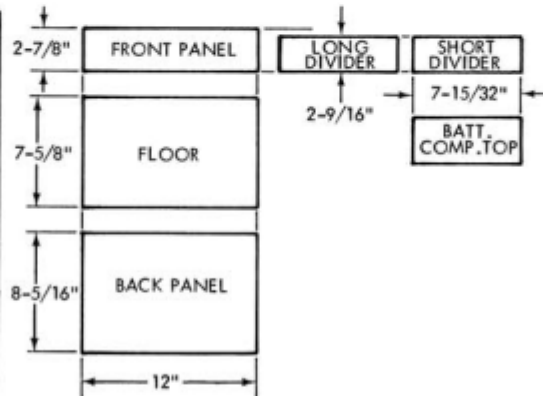
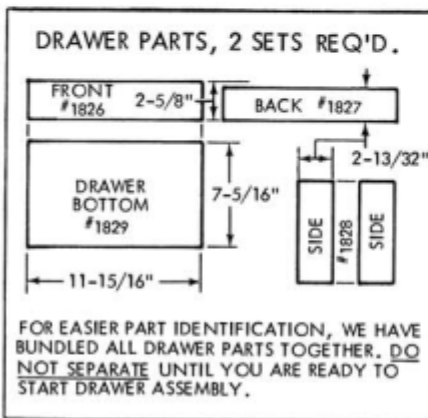

IMPORTANT. During assembly, tape is used to hold parts together for gluing (nails or other fasteners are not required). For good tight joints it is important that the tape be applied firmly. The photos below describe how to do this. We have found that even warped parts will straighten out as they are taped together into a structural unit.

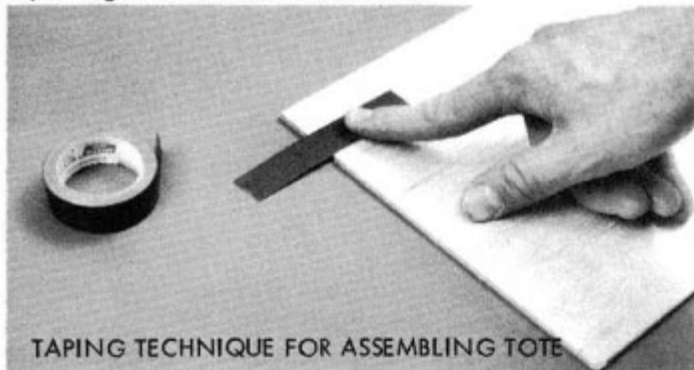

TAPING TECHNIQUE FOR ASSEMBLING TOTE

a). Apply a piece of tape, pressing firmly in place.

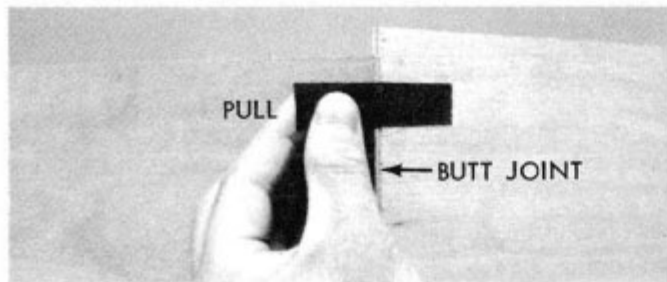

b). Pull tape so parts are held tightly together.

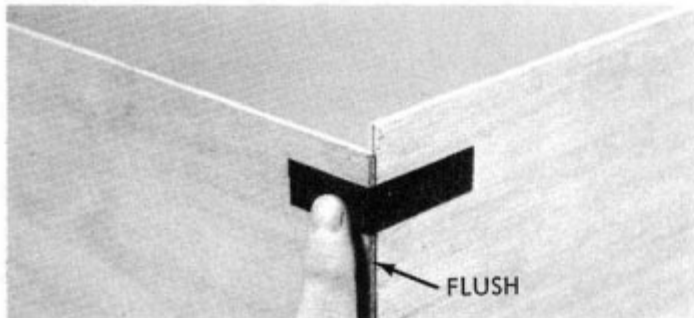

c). Wrap tape firmly around corner. Joint should be tight and parts flush. Adjust where required, apply more tape if necessary.

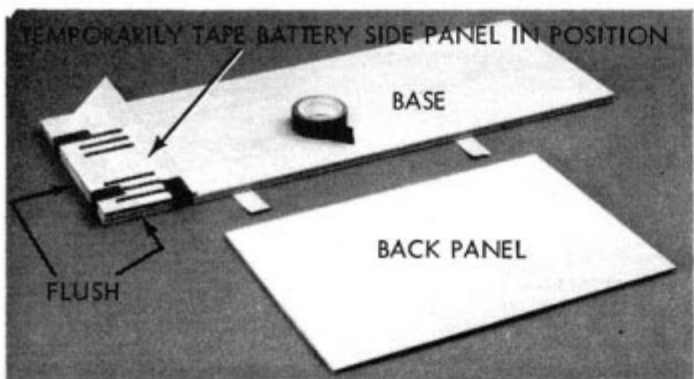

1. Using no glue, temporarily flush one side of battery side panel even with one edge of tote base. Hold in place with tape.
 Apply two tapes to bottom of base leaving them stick out as shown for attachment of back panel.

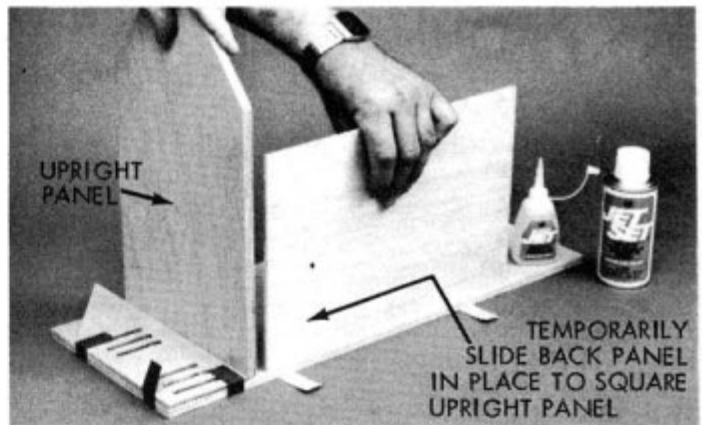

Butt upright panel up against battery side panel. Using back panel, make sure upright is square to base as shown. Set back panel aside.

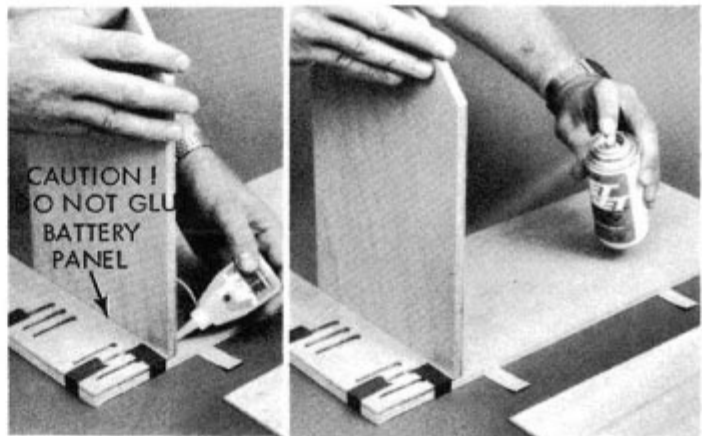

Apply Super Jet along inside corner of upright panel, holding it as straight up as possible (do not glue battery end panel — it is only used here in this step for locating the upright panel)! A short spray of aerosol Jet Set will almost instantly harden the glue and provide a strong glue fillet. Be sure to remove any large lumps of glue at base joint which may interfere with the drawer.

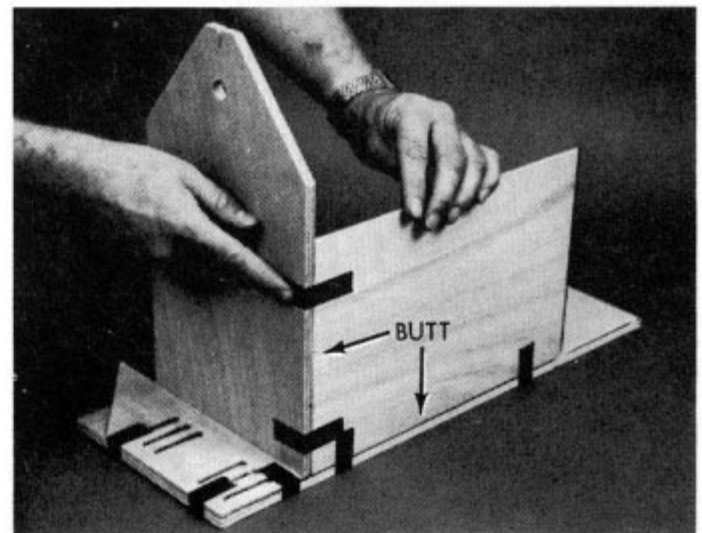

2. Position and tape back panel in place. Note: when adding a new part to a previously glued assembly, for better part fit we recommend that you sand off any sharp edges which may be obstructed by dried glue at corner joints. Do not oversand; just enough to break the corner so it fits well.



□ Glue it to upright and base.

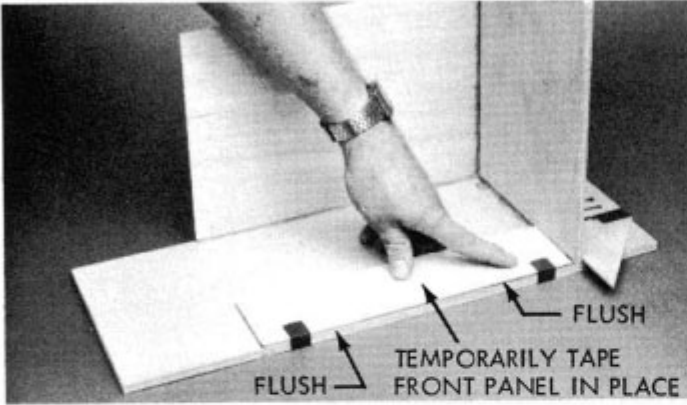
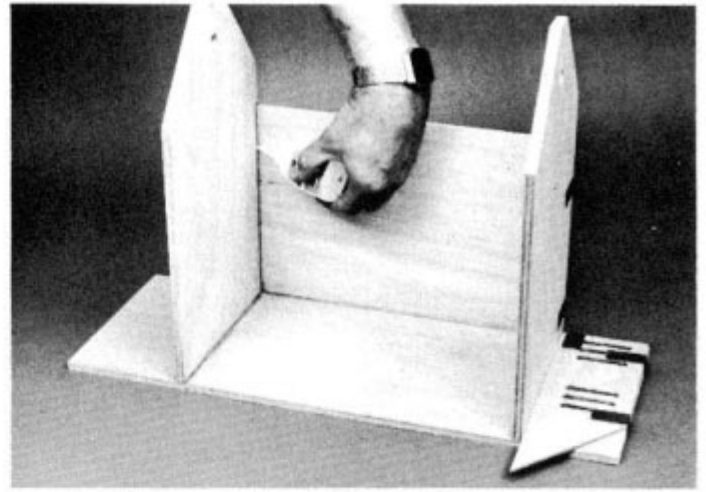

3. □ Turn tote around and butt front panel against upright and tape to base as shown.

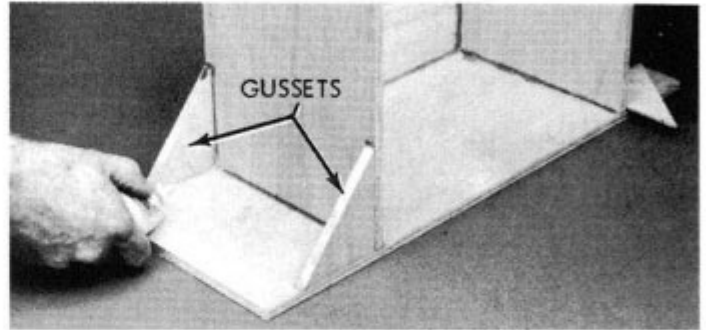

□ Glue gussets in place.

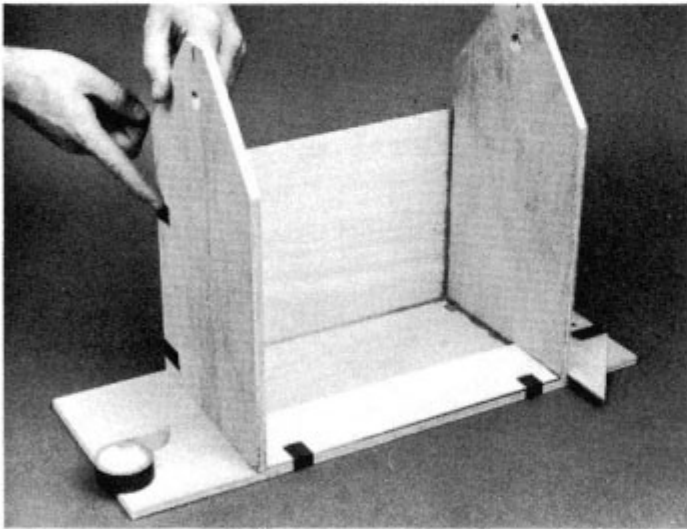

4. □ Position second upright panel as shown above. Tape panel securely to back panel.

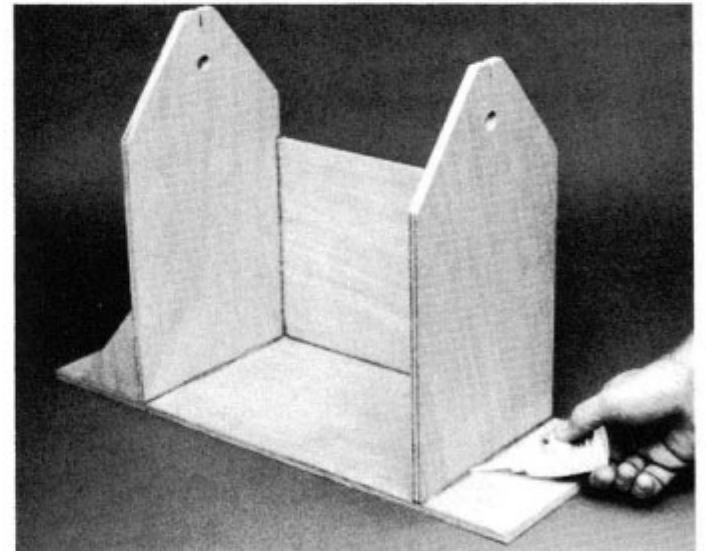

□ Remove front and battery side panels. Check all joints and glue where required.

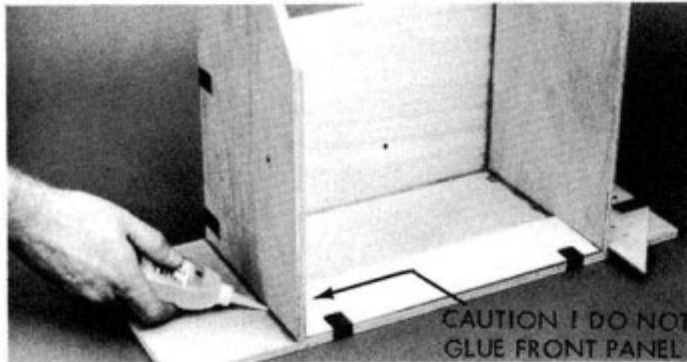

□ Glue upright to base and back panel. Let dry.

DRAWER ASSEMBLY

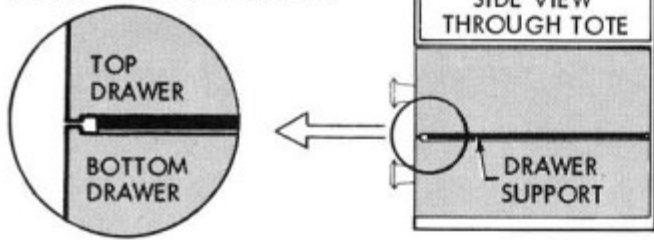

IMPORTANT! Although parts for the drawers are identical, each drawer is assembled in a slightly different way. This is done in order that there is a minimal gap between the two drawers (see sketch). The bottom drawer is assembled first.

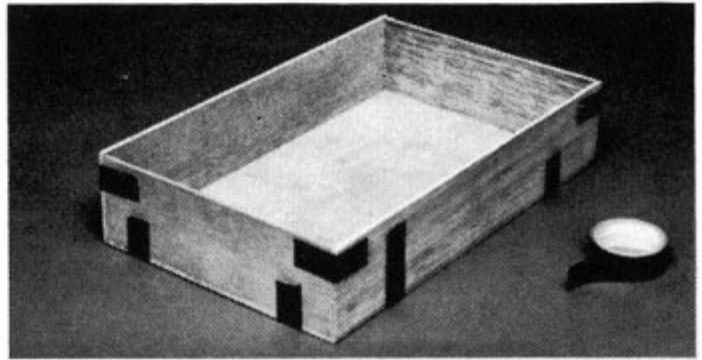

- Position and tape drawer sides to front and bottom.
- Tape drawer rear in position as shown.

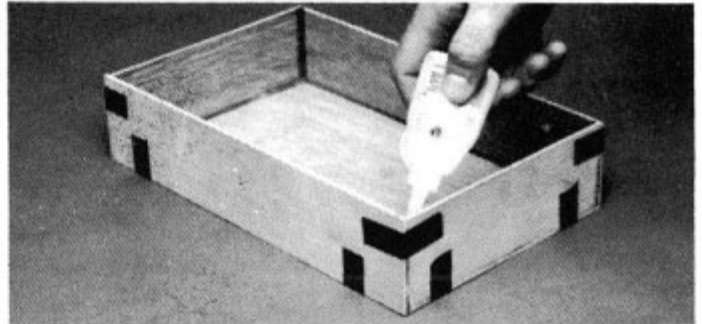

- Adjust parts so all joints are tight and square. Glue drawer thoroughly. Let dry. Mark drawer with a "B" to avoid mixup.

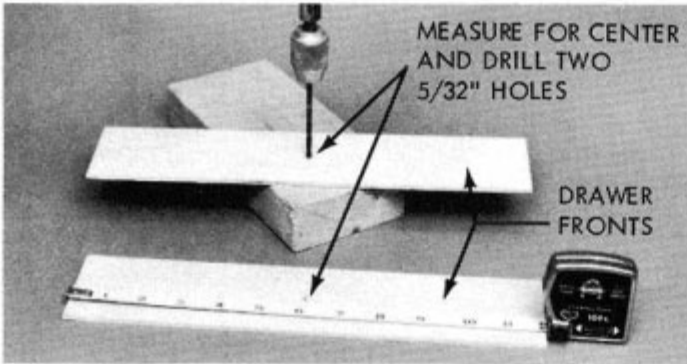

- D1.** Locate the drawer front panels (the wider pair). Measure for center and drill a 5/32" dia. hole through both panels.

TOP DRAWER ASSEMBLY

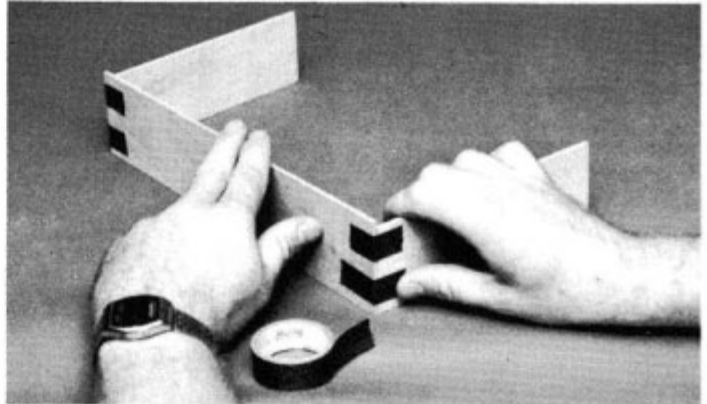

- D2.** Top Drawer Assembly. Tape sides to drawer front being sure that all parts are setting flush on table surface (front will be higher than sides).

BOTTOM DRAWER ASSEMBLY

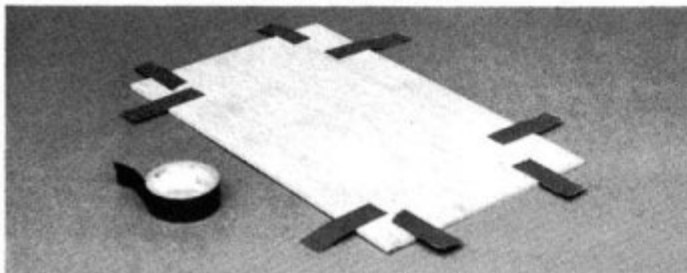

- D1.** Apply tapes to drawer bottom as shown leaving them overhang the edges for attachment of other parts.

BOTTOM DRAWER SIDE VIEW SHOWING HOW PANELS JOIN



TOP DRAWER SIDE VIEW SHOWING PART FIT

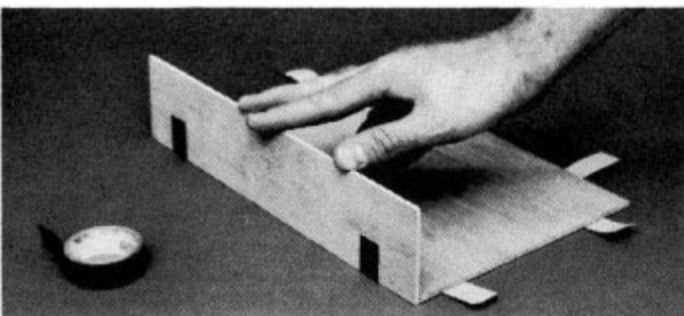

- Position and tape drawer front to one edge of drawer bottom.

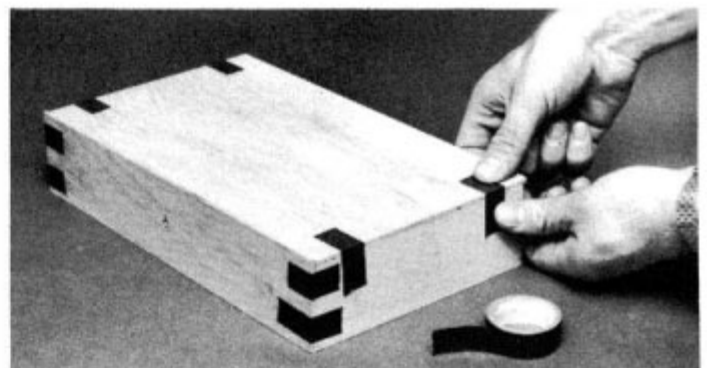

- Position bottom and tape to sides (front panel will be slightly higher than bottom).

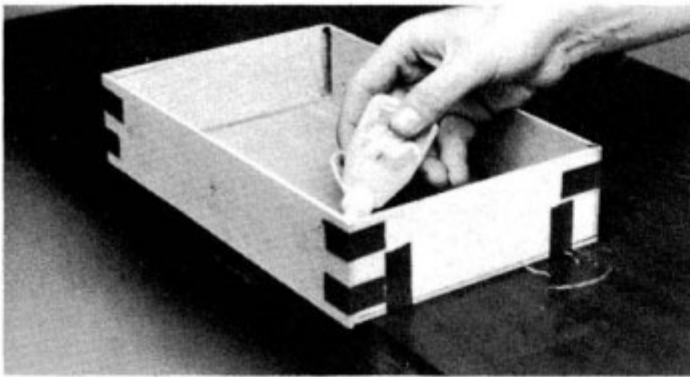

□ Carefully turn the drawer right side up and let the front panel hang over the edge of your table. Tape rear in place.

□ Adjust parts so all joints are tight and square. Glue and let dry. Mark drawer with a "T."

Drawers Complete.

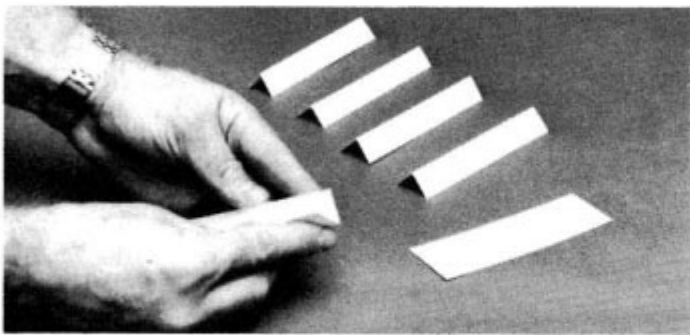

5. □ Using #6 x 1/2" screws attach knobs to drawers.

□ From post card, cereal box or similar material, cut half a dozen spacers 2" wide x 6" long. Fold these spacers in half lengthwise.

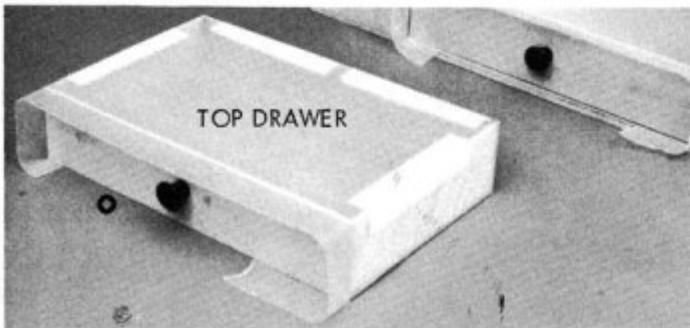
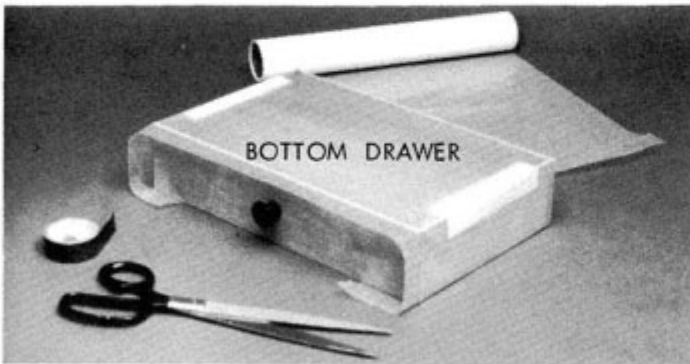

□ Place spacers at drawer sides over the top edges.
□ Wrap both drawers with kitchen plastic wrap or wax paper to prevent their being glued shut during the next few steps.

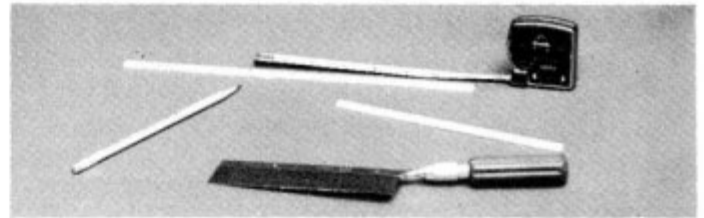

□ From 1/8" x 1/4" bass strips, cut two drawer supports 7-1/4" wide.

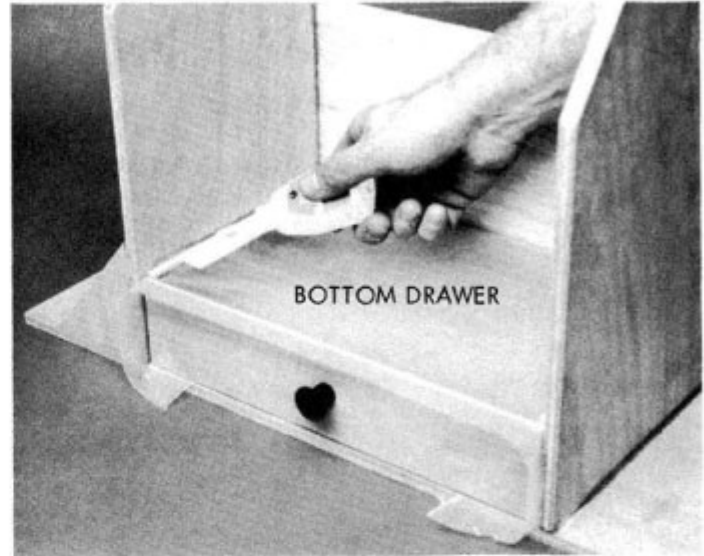

□ Position bottom drawer inside tote.

□ With its end touching the back panel, lay one support flat on drawer side and glue the 1/8" thick edge to upright panel. Glue remaining support over the other drawer side in same manner. Let dry thoroughly.

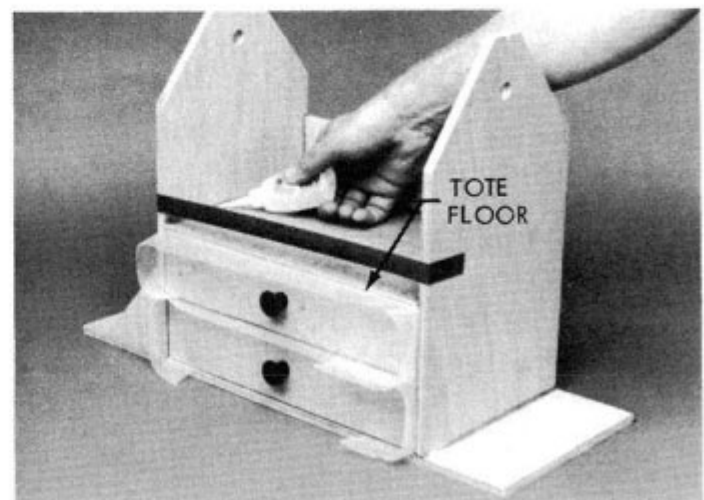

6. □ Position top drawer inside tote and resting on rails previously installed.

□ Position tote floor on top of drawer and flush it with front of uprights. Apply a piece of tape across the front to pull upright panels up tight against floor. Glue floor to uprights and to rear panel. Let dry.

TOP VIEW SHOWING OPTIONAL STARTER LOCATIONS

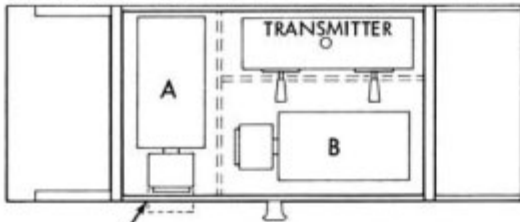

CUT OUT FOR LARGE STARTERS IF REQ'D.

- 7a.** Remove drawers and set aside. The open top compartment was designed to accommodate most popular electric starters. The starter can be stored in either of the two areas shown in sketch above.

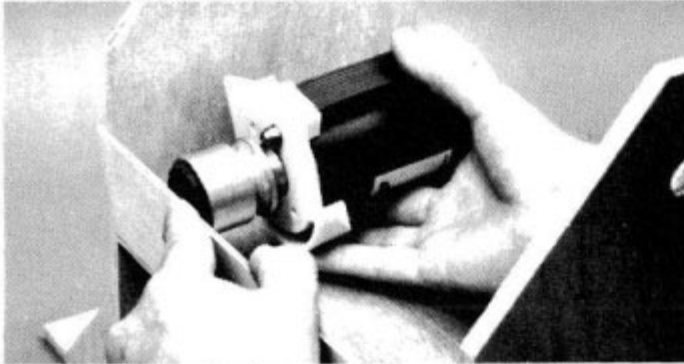

- Holding the front panel in place, try fitting your starter in position as shown above. If the starter will not

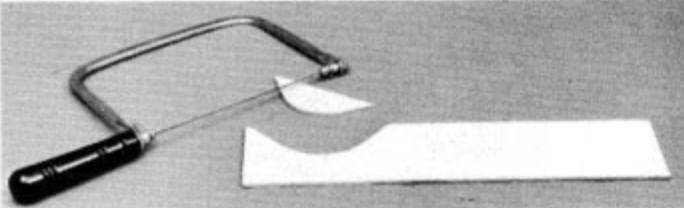

fit in either location A or B, a cut out should be made so starter can protrude beyond the panel.

PROPELLERS LARGER THAN 13" CAN BE MOUNTED ON FRONT PANEL.

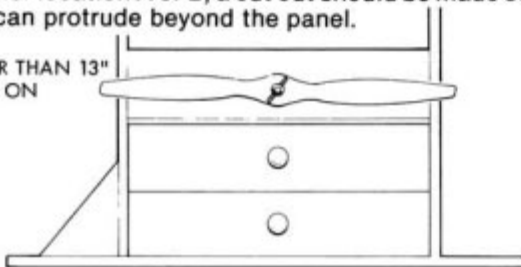

- Propellers larger than 13" will not fit into the drawers (13" props will only fit in diagonally.) For large props, drill a 3/16" dia. hole in the center of the front panel. Props can now be attached to the front panel with a screw and a wing nut (not included).

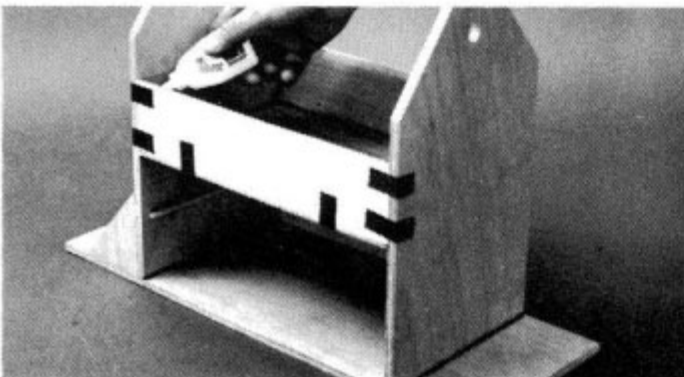

- 7b.** Position front panel so it is flush with uprights and floor. Hold with tape and then glue. let dry.

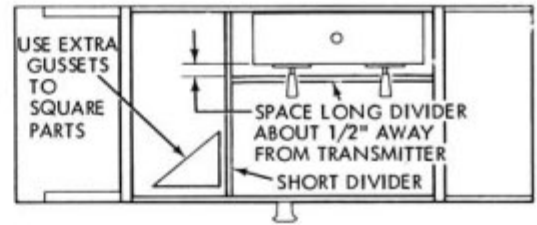

- 7c.** Set your transmitter in Tote and position long and short dividers as shown above.
 Glue dividers in place.

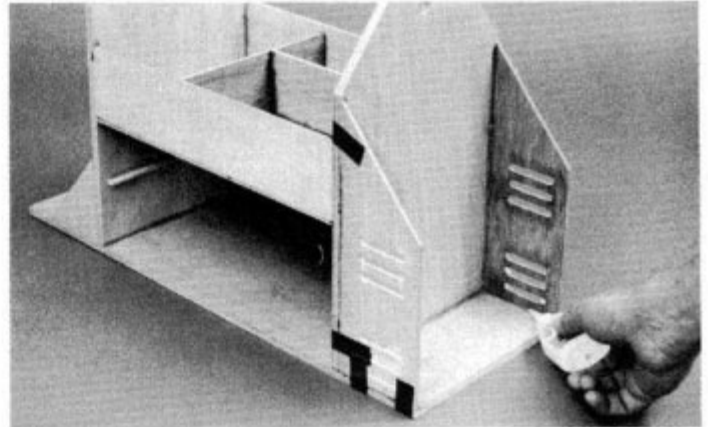

- 8.** Position and tape battery side panels as shown. Glue panels to uprights and base. Let dry.

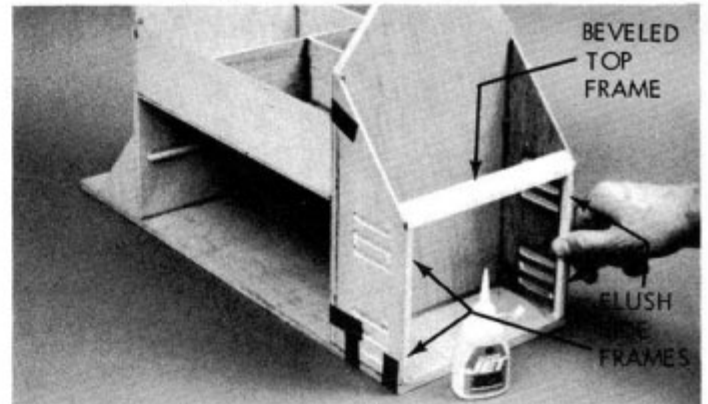

- 9.** Position beveled top frame (pointed edge facing up) between side panels so it is flush with side panel edges. Pull side panels closer together with tape if required to keep it in position. Glue top frame to side panels.
10. Position 1/4" square x 5-11/16" side frames inside battery opening, flush with side panels as shown above. Glue to top frame, side panels, and base.

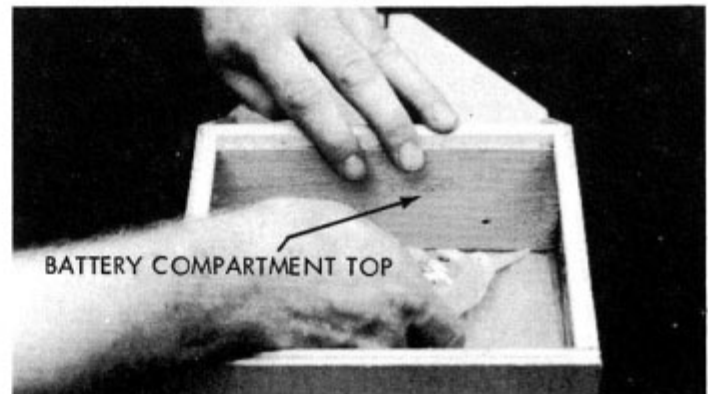

- 11. IMPORTANT!** To guard against potential battery gas explosion from power panel electrical operation, the bat-

tery top panel must be installed as described below.
 Position the battery top panel inside the compartment and push it up flat against the bottom of the top frame. Glue top panel in place. Apply glue all around panel for an air tight seal.

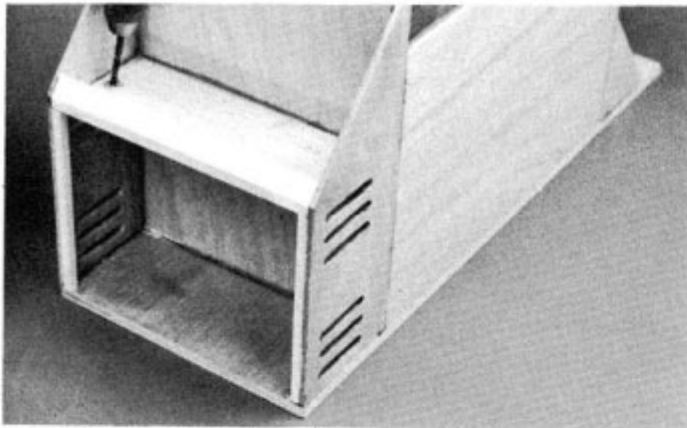

Drill a hole through top panel for passage of your power panels wiring harness. Locate this hole towards either end of panel.

12. The Super Tote was designed to accommodate all popular electric power panels. Because there are so many different panels with various features and sizes, you will have to fit your panel in place. A hole must be cut in the mounting panel large enough for clearance of electrical components protruding out the back of your power panel. Measure carefully for this opening.

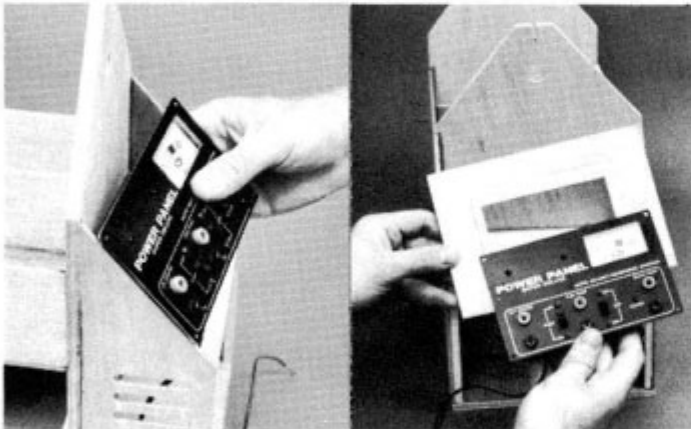

First hold your panel in approximate final location. All panels have components that project out from the back. Locate your panel so rear components do not jam against tote interior.
 Once established, mark power panel location on mounting panel. We have die-cut a small opening in the mount as a convenient place for you to start making the opening for your panel.

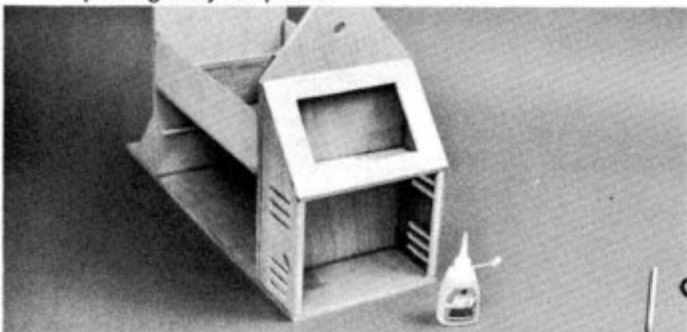

Glue mounting panel to top frame, upright and side panels.

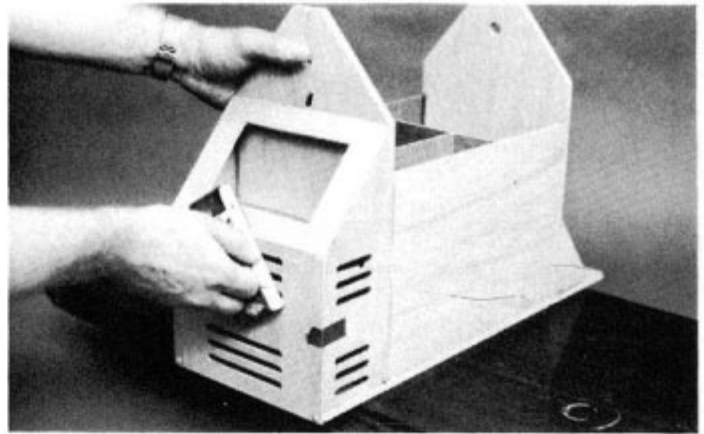

13a. Note: The battery end panel is not symmetrical, the end with vent slots closest to the edge is the top. Position battery end panel so it is butted up under lip of mounting panel and flush with battery side panels. Hold in place with tape.
 Drill two 1/16" diameter holes at lower punch mark locations. Attach end panel with two #4 x 3/8" screws at bottom only.
 Carefully sand the mount panel flush with the end panel.

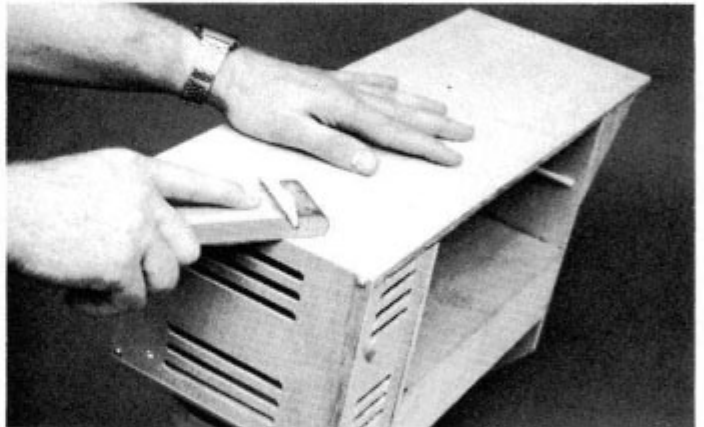

13b. Install two #4 screws at upper punch mark locations.
 Turn tote bottom side up and sand (or cut) end panel flush with base.

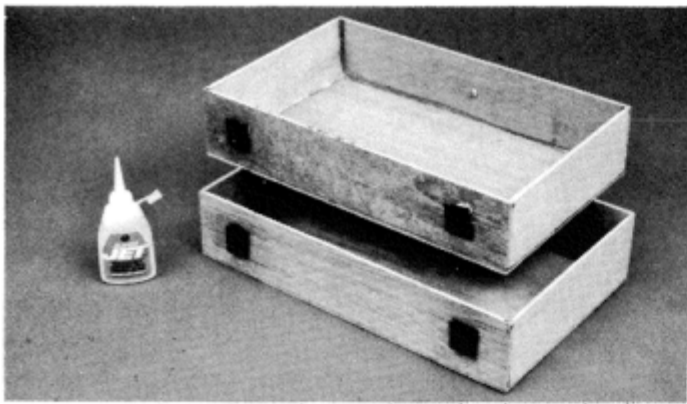

- 14a.** Carefully glue velcro pads to the drawer backs as shown. Spray Jet Set on the velcro for faster bonding to the wood.

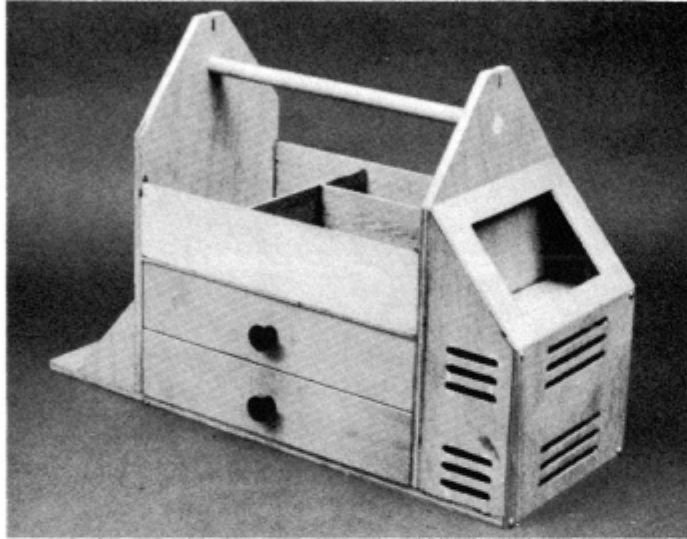

- 14b.** Lay tote over on back panel.
 Carefully apply glue to velcro pads and install drawers in tote (Caution: too much glue may bleed and glue drawer permanently shut, be careful!) Set weights on drawers in order to hold velcro pads tight as glue dries. Let dry thoroughly.
 Install handle and glue firmly to upright panels.



- 15.** A nylon strap is furnished for holding your fuel can in place. There are many other ways of fastening the can, a back pack type adjustable strap is one example.
 Bend nylon strap over about 1/2" from one end.
 About 6" up from the tote base, attach doubled over end of nylon strap to upright panel with #4 screw and washer.
 Set your fuel can in place on tote and pull strap

securely around it. Allow enough strap material for attaching to tote with about 1/2" excess for doubling over. Install strap with a #4 screw and washer, and cut off excess material.

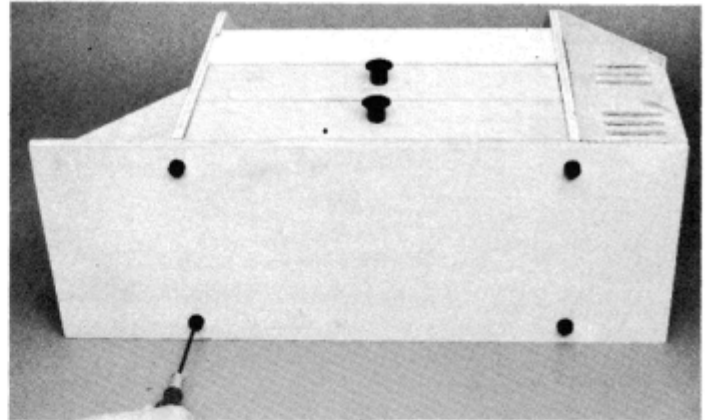

- 16.** Install four rubber cushions on tote bottom using #4 screws.

BATTERY FITTING

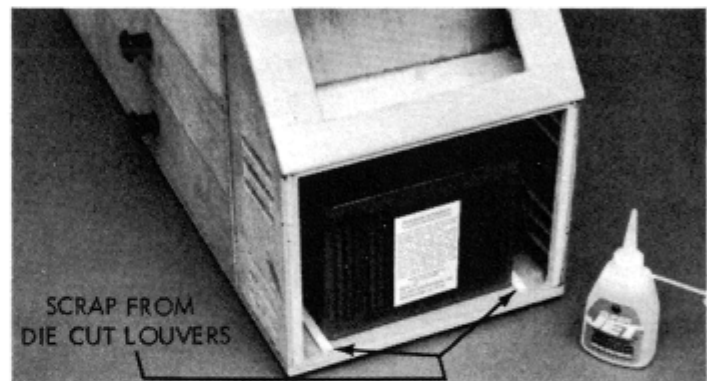

- 17.** Remove battery end panel and set battery in position. Glue scrap strips to base at both sides of battery to prevent sideways shifting.

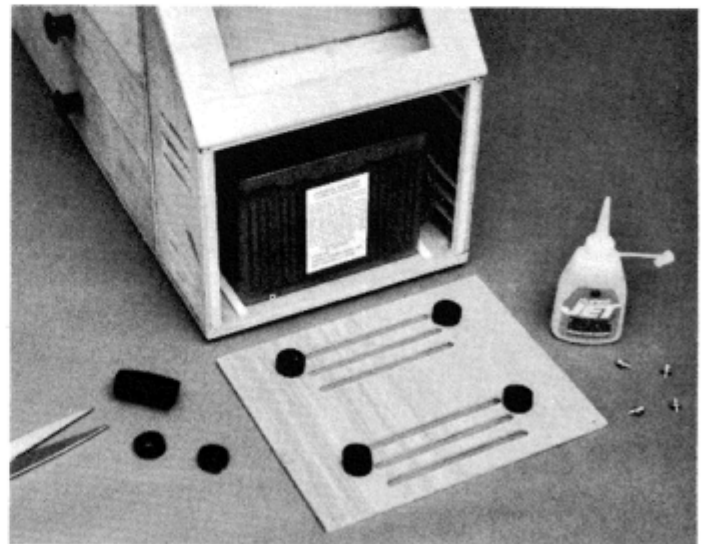

- From sponge tubing, cut thin sections and glue them to end panel interior as shown. They must be cut just long enough to restrict battery movement when end panel is in place. They should be glued as close as possible to the mounting screws to avoid causing the end panel to bulge when screwed in place.

AIRPLANE CRADLE ASSEMBLY

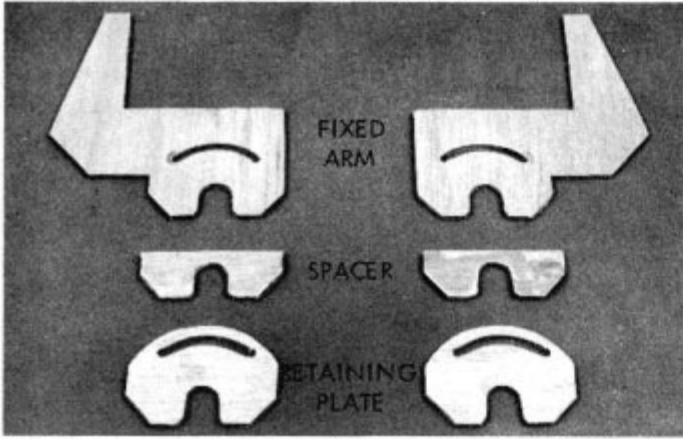

1. □ Remove all cradle parts from die cut sheets. Arrange parts for fixed arm as shown above, making one left and one right cradle assembly.

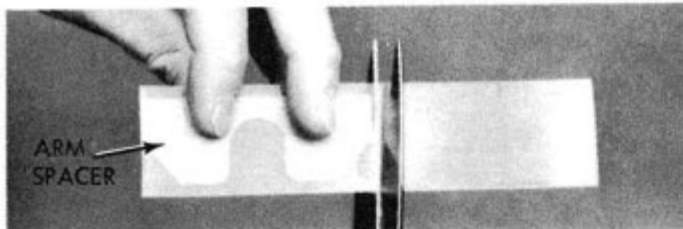

2. □ Locate the thin plastic, 1-1/2" x 6". Sand it on both sides.
□ Cut it into two equal pieces to match the arm spacer, as shown above.

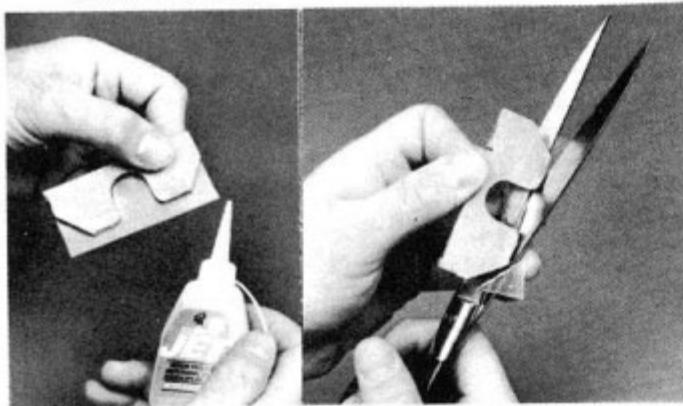

- Glue plastic piece to spacer. Glue remaining piece to second spacer.
- Carefully trim plastic to match spacer shape.

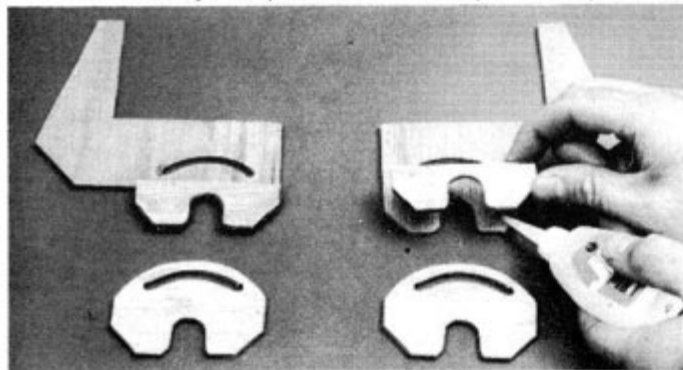

3. □ Before using any glue, temporarily try parts in place to check fit and placement. Position spacer on fixed arm.
□ Glue spacer to fixed arm.

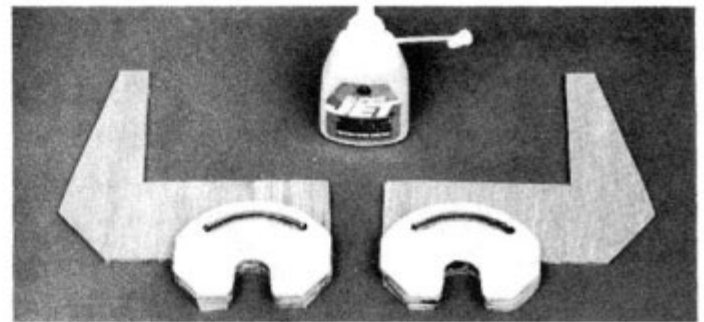

4. □ Position retaining plate on spacer. Glue in place.

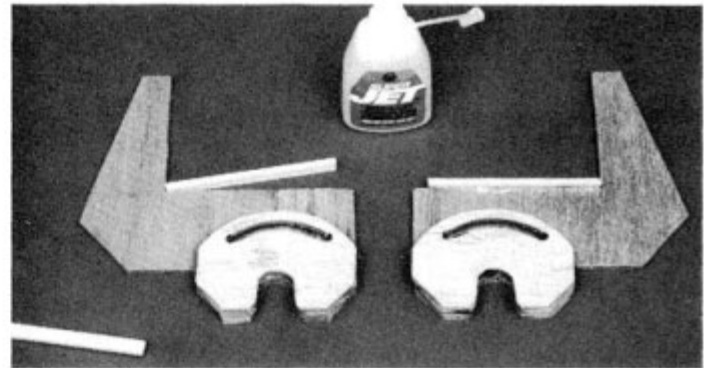

5. □ From 1/8" x 1/4" wood strip, cut two 3-1/2" long pieces.
□ With cradle still flat on table, glue these parts to the long flat edge as shown.

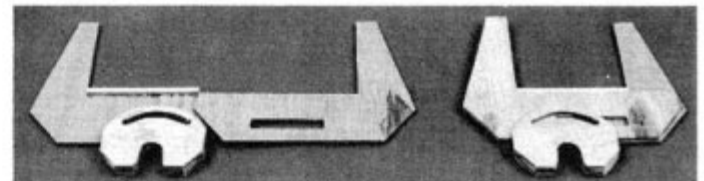

COMPLETED CRADLES SHOWING HOW ADJUSTABLE ARM SLIDES INTO FIXED ARM.

ASSEMBLING CRADLE HARDWARE

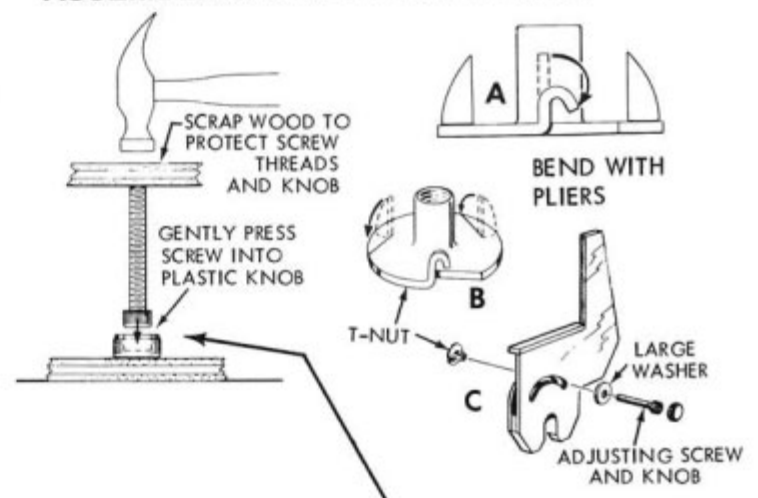

6. □ Using a hammer, carefully press socket head screw into plastic knob as shown in sketch above. Repeat for remaining screw and knob.
□ Bend one point of blindnut over as shown in sketch "A" above. This bent point functions as a key that engages the cradle slot. Bend remaining points flat as shown in sketch "B." Installation of hardware is shown in sketch "C."

CRADLE INSTALLATION. Set cradle on Tote handle while sliding adjusting screw into top slot. With cradles fully seated on wood handle, adjust for desired width (and tilt). Tighten adjusting screw to hold position.

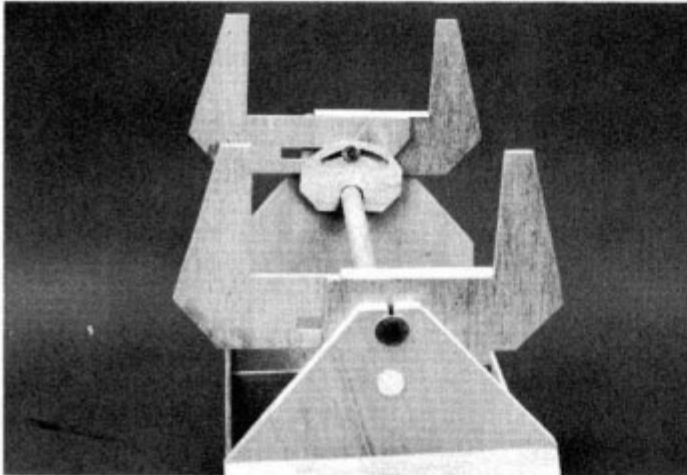

Cradles. The unique Super Tote cradles adjust to fit different fuselage widths. They also tilt to improve accessibility during model building and maintenance. With cradles in fully upright position, they adjust from approx. 3-1/4" minimum closed to about 5" wide fully open. For those times when you wish to tilt the model while working on it, the cradles will rotate about 35° in either direction from the fully upright position. If you should even need to open the cradles more, they will open to 6" wide if rotated down in the direction of the fixed arm.

APPLYING CRADLE SPONGE TUBING

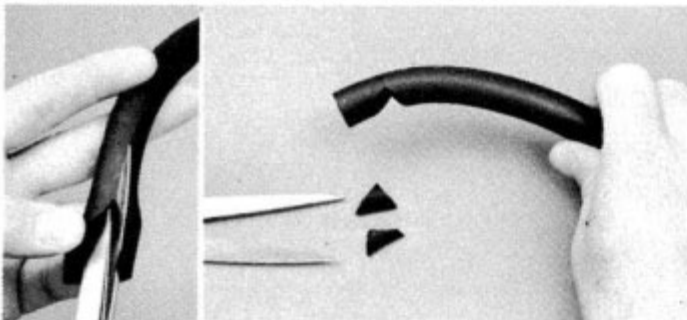

1. From sponge tube, cut two lengths 7-3/4" long and two lengths 3-3/4" long.
 With a scissor or knife, carefully slit the tubing.
 Cut a notched corner out of tube as shown above so it will fold easily around top edge of cradle arms.



SPONGE CUSHION INSTALLED ON FINISHED CRADLE. (NOTE: CUSHION IS INSTALLED ONLY ON THE VERTICAL EDGE OF THE ADJUSTABLE ARM).

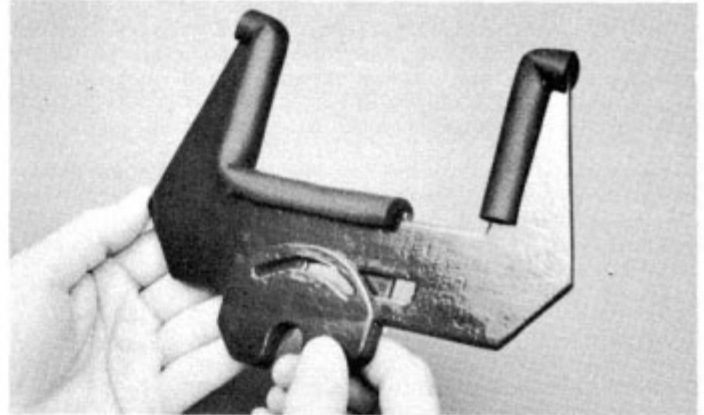

- Apply a running bead of glue to cradle edge. Spread tube over cradle and press in place on glued edges.

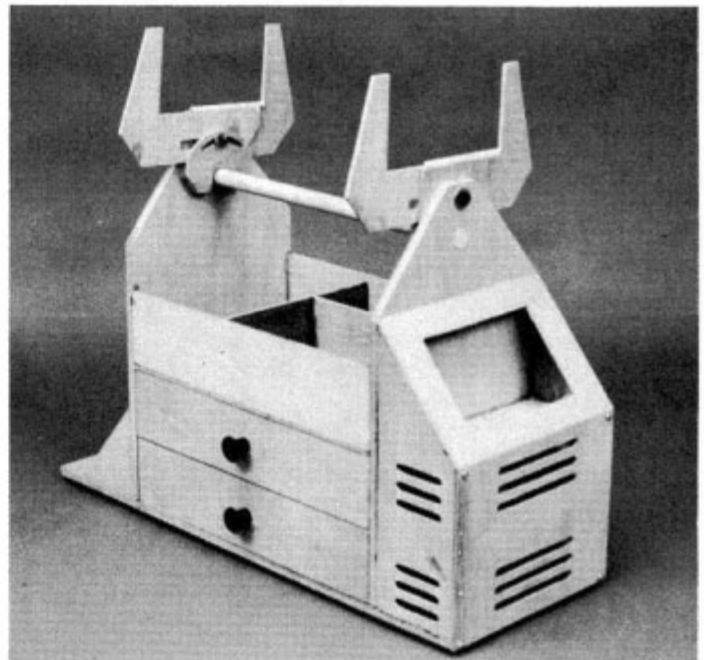

TOTE COMPLETE, READY FOR FINISHING AND PAINTING.

FINISHING AND PAINTING

Epoxy paints are strongly recommended since they are fuel proof. However, they do have to be carefully mixed before using. Polyurethane paints can be used right out of the can and are also fuel resistant. But, depending on humidity, polyurethane paints may be slow to dry. At the end of this section there are instructions on applying an optional clear finish.

For a smooth, good-looking final appearance, we recommend spending some time preparing the wood surfaces for painting. If most of your effort goes into the prep work, paint will flow and cover better, producing a high quality finish you'll be proud of. Painting alone will not hide defects. To smooth out grainy wood, joints, etc., use modeling grade wood filler, or equivalent. Even household "vinyl" spackle works well as a filler, although when dry it dents easily. Use whatever material you feel comfortable with, just be sure it sands down easily. Although more expensive, polyester resin is very easy to use since it usually only takes one coat to fill the surface. It dries to a hard surface in about an hour regardless of humidity. And it sands well.

1. So that all surfaces are unobstructed for sanding and painting, remove all screws, drawer pulls, etc. Set these items aside for final assembly after painting. Similarly, the cradles should be disassembled so each part can be carefully sanded and individually painted.

2. Apply paste fillers using a knife blade or plastic scraper to squeegee filler into wood pores, especially in end grain of the base and upright panels. Liquid fillers should be brushed on. Repeat applications may be required. Allow filler to dry thoroughly.

3. Wrap 100 grit sandpaper on a block and flat sand all exterior surfaces of the Tote. If desired, take a little more time to smooth out interior areas of drawers and open top compartments. Interior of battery compartment does not require any sanding. Repeat sanding with 220 grit until surface begins to smooth out. Repeat steps 2 & 3.

4. Remove all sanding dust from surfaces. Apply a good coat of primer and let dry. Additional applications of primer may be needed at porous areas (corners, end grain). Sand primed surfaces with 220 grit paper. If required, apply additional prime coats, sanding between coats until the surface begins to smooth out. For final sanding, switch to 400 grit wet/dry sandpaper.

5. Using a tack rag, thoroughly wipe down the Tote and remove all excess dust. Following the paint instructions, apply a very thin coat and allow to dry. Apply additional coats lightly, gradually building up the color intensity. Heavy applications of paint will run.

The color band around the tote is decorative and also serves to identify the top drawer. Mask the Tote for this band and apply your favorite color (we used dark blue). The thin accent stripe can either be masked and painted on along with the large band or made from CG Color Stripe tape.

Cut decal sheet apart in sections as needed. Dip each section in lukewarm water for about half a minute. Remove and allow to stand. In about a minute, decal will begin to loosen. Then slide off onto moistened area on Tote. With soft cloth or cotton, smooth out carefully to remove air bubbles and excess water. The decals are fuel resistant to all common model fuels.

CLEAR FINISHING. Follow steps 1, 2, & 3 above, except use plastic wood (mahogany) to fill nicks and dents. Apply first clear coat (such as K & B Clear Epoxy). End grain areas will be more absorbant, requiring repeated application until wood pores are filled. When dry, use 300 grit sandpaper between coats to smooth out the surfaces. Be careful not to sand through to the bare wood, especially on corners and edges. Usually about 3 or 4 coats with sanding between coats are required for a good finish. Wipe the entire Tote down with a "tack" rag so surfaces are dust free. Then final sand with 400 wet/dry paper. Apply a final coat of K & B Clear Epoxy (if possible, spray for best results).

SAFETY INSTRUCTIONS & WARNINGS FOR CARL GOLDBERG FLITE BOXES

Important: For your own safety and that of others, observe the following instructions and warnings:

1. Never use the flite box for engine testing or while an engine is running. The cradles are designed only for holding the model when building, repairing or storing.

2. Remember that model fuel is highly inflammable and explosive!! Therefore, treat it with utmost care. Do not allow anything to come near the fuel can that could set off a spark; do not smoke or bring any flame near the fuel can. Use care when carrying your Tote so as not to drop the unit with the can on or in it or bang the can. If you store any battery (e.g. glow plug starter battery) or electrical device in your Tote, make certain that no short circuit can occur; wrap the plug end in insulation and keep terminals from shorting out.

3. Make certain any fuel can mounted on your Tote does not leak; inspect frequently for this. Make certain it is sealed tight and that it does not come in contact with any battery, electrical device, tool, or anything that might cause a spark or excessive heat.

4. If you mount any kind of power panel into your Tote, be certain to run its leads so as to avoid shorting out, causing sparking or excessive heat; the same precautions must be used when mounting any electric fuel pump in your Tote.

5. At all times and in all cases —

Remember that you are carrying highly flammable fuel close to batteries, tools and other devices that may cause sparks, short circuits or cause heat high enough to ignite the fuel.

Use good common sense. Keep all pump wiring or panel wiring you choose to install in good condition and safely wired without crowding.

DON'T keep matches, lighters or anything in your Tote that might cause a spark or flame.

6. Keep your Tote out of the way of any running engine or its exhaust.

7. Store your Tote in a safe place — keeping children and others away from your Tote at all times. Do not carry or store in the trunk of a car during hot weather.

8. From time to time inspect all fasteners used to hold components on your finished Tote to be certain they are secure.

**THE FAILURE TO OBEY THESE SAFETY INSTRUCTIONS
AND WARNINGS MAY RESULT IN FIRE, EXPLOSION
OR OTHER CASUALTY CAUSING SERIOUS
PERSONAL HARM OR PROPERTY DAMAGE
TO YOURSELF OR OTHERS!**

Tools and Supplies Needed

- 2 oz. Super Jet or 15 minute Epoxy Glue
- Jet Set (cyano. accelr. — optional)
- 3/4" wide drafting, masking, or scotch tape (for holding parts during assembly)
- 4 sheets 120 grit sandpaper
- 4 sheets 220 grit sandpaper
- 2 sheets 400 grit wet/dry sandpaper
- Sandpaper block
- Hammer, scissors, small pliers, ruler
- Small coping or jig saw
- Screwdrivers (1/8" & 1/4" blade tips)
- Waxpaper or plastic wrap

FINISHING MATERIALS

- Small 4 oz. can wood filler material
- Small can wood sealer (polyester resin, etc.)
- Paint — epoxy or polyurethane
Optional colors; white or cream, dark blue
for band & cradles
- Thinner, brushes, mixing cups, etc.

OPTIONAL FOR CLEAR FINISH

- K & B Clear and Hardener (or polyurethane varnish)
- Plastic Wood-filler (mahogany)
- Wood stain (optional)

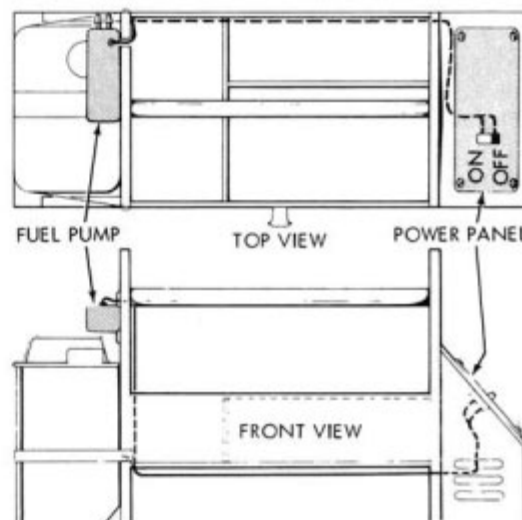

TYPICAL FUEL PUMP INSTALLATION

Super tote

shown with the
Manual Composit
pump from SI iml ine
Products



Super tote

Shown with the Boxxer
Electric fuel pump
from SI iml ine
Products



Super Tote

Shown with the SI 2000 electric pump from SI inline Products. Note: the aircraft cradles cannot be used with this type pump.



Super Tote

Shown with the Super X Electric fuel pump from Sonic-Tronics



Sources for Additional Items used in Super Tote

Slimline Mfg. Inc.

P.O. Box 3295
Scottsdale AZ. 85271-3295

Phone number 480 967 5053
Fax 480 967 5030

SL-2000 Model Fuel Pump
Boxxer Model Fuel Pump
Manual Composit Pump
Pro Bottle Cap

Sonic-Tronics Inc.

7865 Mill Road
Elkins Park, Pa. 19027

Super "X" Electric Fuel Pump

sot250 3.6v-6v DC
sot1250 7.5v-12v DC

Mark "X" Electric Fuel Pump

sot249 3.6v-6v DC
sot1249 7.5v-12vDC

Glow Plug Caddy

sot260

Magna-tray

sot261

Ni-Starter

MCD101 1.5" with 110v AC Charger
MCD105 1.5" NI-Starter only
MCD217 2.5" with 110v AC Charger
MCD218 2.5" Ni-Starter only
MCD204 3.5" with 110v AC Charger
MCD208 3.5" Ni-Starter only
MCD202 Remote NI-Starter w/110v AC Charger
MCD203 Remote NI-Starter Only

Hobbico

P.O. Box 9021,1610 Interstate Drive
Champaign, Illinois 61826-9021
Order only 800 637 7660
Dealer only order support 800 262 7885

HCAP0302 Deluxe Power Panel II
HCAP3105 Top Fueler MKIII 12v Fuel Pump
HCAP3107 Pnl Fdy Top Fueler MKIII 12v Fuel Pump
HCAP3015 Hand Crank Fuel Pump

Hot-Shot 2 Glo-Starters

HCAP2520 2" Standard Hot-Shot 2
HCAP2522 3" Long Hot-Shot 2
HCAP2528 Super Hot-Shot 2

TorqMaster 90 & 180 Starters

HCAP0901 Power Core 12v MKII Starter Power Pack
HCAP0905 Power Core Battery Pack only
HCAP0210 12v Power Core Charger w/Led
HCAP3200 TorqMaster 90 Starter
HCAP3205 Panel-Ready TorqMaster 90 Starter
HCAP3300 TorqMaster 180 Starter
HCAP3305 Panel-Ready TorqMaster 180 Starter

Maxx Products

815 Oakwood Rd. Unit D.
Lake Zurich, Il. 60047
Order only 800 416 MAXX(6299)
Info 847 438 2233
Fax 847 438 2898

ACC116 Electric fuel pump
ACC244 Hand crank fuel pump
ACC108 Power Panel.

Sullivan Model Products

1 North Haven Street
Baltimore, MD 21224
Phone 410 732 3500
Fax 410 327 7443

M040 Head Lite with NiCad Battery
M041 Head Lite with NiCad Battery and Wall Charger
M045 Head Lite without battery
M054 Head lite Extended with NiCad Battery
M038 Metered Head Lite with NiCad Battery
M039 Metered Head Lite w/NiCad Battery and Charger
M055 Metered Head Lite Extended with NiCad Battery

S600 Hi-Tork Starter
S601 Deluxe Hi-Tork Starter
S603 Dynatron Starter