

SOPHISTICATED LADY



Wingspan: 78 in [1980mm] **Wing Loading:** 5.8–6.4 oz/sq ft [17.7–19.5 g/dm²]
Wing Area: 674 sq in [43.5 dm²] **Length:** 41-3/4 in [1060mm]
Weight: 27–30 oz. [765–850 g] **Radio:** 2-channel with standard servos

WARRANTY

Carl Goldberg Products guarantees this kit to be free from defects in both material and workmanship at the date of purchase. This warranty does not cover any component parts damaged by use or modification. **In no case shall Carl Goldberg's liability exceed the original cost of the purchased kit.** Further, Carl Goldberg reserves the right to change or modify this warranty without notice.

In that Carl Goldberg has no control over the final assembly or material used for final assembly, no liability shall be assumed nor accepted for any damage resulting from the use by the user of the final user-assembled product. By the act of using the user-assembled product, the user accepts all resulting liability.

If the buyer is not prepared to accept the liability associated with the use of this product, the buyer is advised to return this kit immediately in new and unused condition to the place of purchase.

To make a warranty claim Hobby Services
send the defective part 3002 N. Apollo Dr., Suite 1
or item to Hobby Services Champaign, IL 61822 USA
at this address: (217) 398-8970 Ext. 5

www.carlgoldbergproducts.com

Include a letter stating your name, return shipping address, as much contact information as possible (daytime telephone number, fax number, e-mail address), a detailed description of the problem and a photocopy of the purchase receipt. Upon receipt of the package, the problem will be evaluated as quickly as possible.

READ THROUGH THIS MANUAL BEFORE STARTING CONSTRUCTION. IT CONTAINS IMPORTANT INSTRUCTIONS AND WARNINGS CONCERNING THE ASSEMBLY AND USE OF THIS MODEL.



TABLE OF CONTENTS

ADDITIONAL ITEMS REQUIRED	2
Radio Equipment	2
Hardware and Accessories	2
Adhesives and Building Supplies	2
Optional Supplies and Tools	2
PREPARATION	2
ASSEMBLE THE WING	3
INSTALL THE FIN	3
INSTALL THE STABILIZER	5
INSTALL THE RADIO SYSTEM	5
FINISH THE SAILPLANE	8
Canopy Installation	8
Apply the Decals	10
GET THE MODEL READY TO FLY	11
Check the Control Directions	11
Set the Control Throws	11
Balance the Model (C.G.)	12
Balance the Model Laterally	13
CHECKING FOR WARPS	13
PREFLIGHT	13
Identify Your Model	13
Charge the Batteries	13
Ground Check & Range Check	14
AMA SAFETY CODE	14
General	14
Radio Control	14
CHECK LIST	14
FLYING	15
Mount the Wing	15
Trim Flights	15
Your First Hi-Start Launches	16
First Flights	16
Thermal Flying	16
Facts About Thermals	16
Thermal Soaring	17
POINTERS FOR CONTEST FLYING	17
Ballasting	18



ADDITIONAL ITEMS REQUIRED

RADIO EQUIPMENT

The Sophisticated Lady ARF requires a two-channel radio system with standard size servos. The following servos are recommended. A square receiver battery or a small flat receiver battery is required to fit the narrow fuselage.

- (2) Futaba® S-3003 Standard Servo (FUTM0031)
- (1) HydriMax™ 1400mAh NiMH flat receiver battery (HCAM6306)

HARDWARE AND ACCESSORIES

Following is additional hardware and accessories required to finish the Sophisticated Lady ARF. Order numbers are provided in parentheses.

- 1/4" Foam Rubber (GPMQ1000)
- #64 Rubber Bands (HCAQ2020)

ADHESIVES AND BUILDING SUPPLIES

In addition to common household and hobby tools, this is the “short list” of the most important items required to assemble the Sophisticated Lady ARF. Great Planes Pro™ CA glue is recommended.

- Thin CA (1/2 oz. [15g] Thin Pro CA, GPMR6001)
- Medium CA (1/2 oz. [15g] Medium Pro CA+, GPMR6007)
- 6-minute Pro Epoxy (4oz [113.4g] GPMR6042)
- 30-minute Pro Epoxy (4oz [113.4g] GPMR6043)
- Mixing Sticks (GPMR8055)
- Epoxy Brushes (GPMR8060)
- Epoxy Mixing Cups (GPMR8056)
- Paper Towels
- Masking Tape
- CA applicator tips (HCAR3780)
- Threadlocker thread locking cement (GPMR6060)
- #11 blades (5-pack, HCAR0211)
- #1 Hobby knife (HCAR0105)
- #44 or 3/32" [2.4mm] drill bit
- Denatured Alcohol
- Wax Paper
- Needle-nose Pliers

OPTIONAL SUPPLIES AND TOOLS

Here is a list of optional tools mentioned in the manual that will help you build the Sophisticated Lady ARF.

- Stick-on segmented lead weight (GPMQ4485)
- Hobby paints/paint brushes for painting the pilot
- CA debonder (GPMR60390)
- CG Machine™ (GPMR2400)
- RC 56 Canopy Glue
- High Start (DYFP8305)

A model airplane covering iron with a protective covering sock may also be necessary to retighten the covering and remove any wrinkles that may have formed after the model was originally covered at the factory. If you don't already have a covering iron, the 21st Century® sealing iron (COVR2700) and the 21st Century iron cover (COVR2702) are recommended.



PREPARATION

1. Lay three or four paper towels over each other and cut the stack into small squares. The small paper towel squares, dampened with denatured alcohol, will come in handy for epoxy cleanup and other general cleanup during assembly.

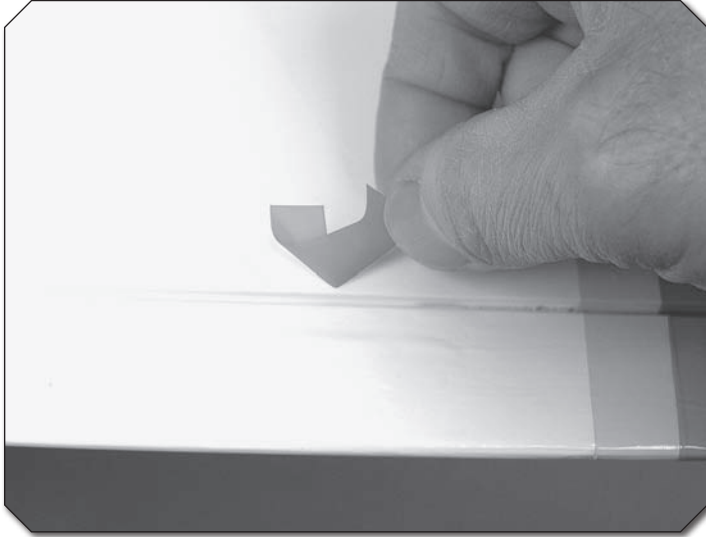

2. Remove the masking tape holding all the control surfaces to their main parts. If necessary, clean off any residual tape glue with a couple of your paper towel squares dampened with naphtha (lighter fluid).



3. Using a sealing iron, remove any wrinkles in the covering before assembly.



ASSEMBLE THE WING

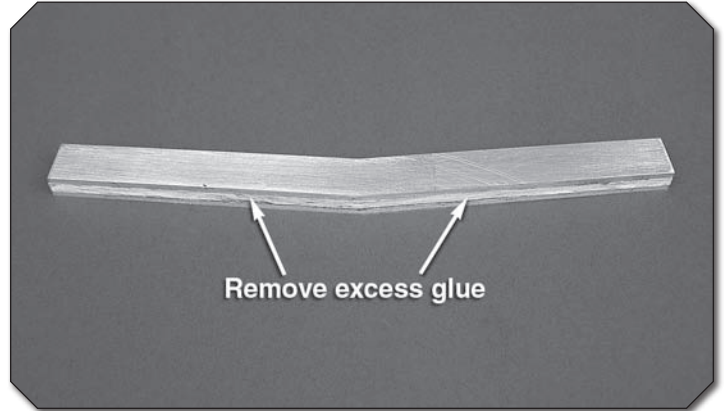

1. Using 220-grit sandpaper, remove any excess glue from the sides, top and bottom of the aluminum and plywood wing joiner. Clean the wing joiner with denatured alcohol and a paper towel.

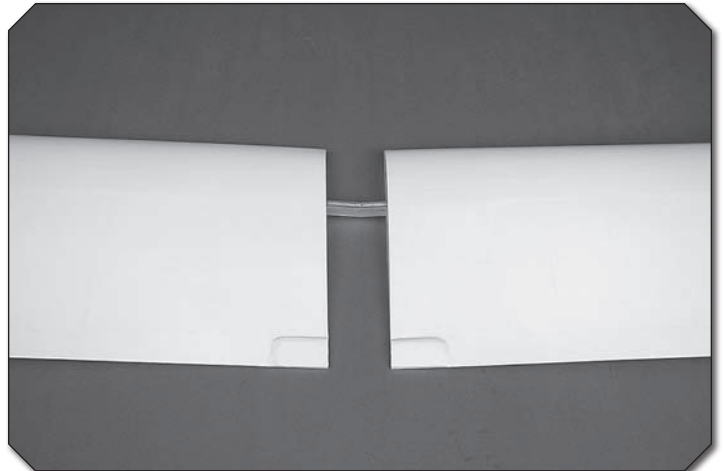

2. Check the fit of the wing joiner in the wing panels. Remove any excess material from the joiner to allow the panels to fit together. Gather everything required for gluing the wing joiner and wing together including, 30-minute epoxy, mixing sticks, epoxy brush, 12" [304mm] long dowel or wire, denatured alcohol and paper towels. Mix up 1/2 oz. [14.8cc] of 30-minute epoxy. Working quickly, pour a generous amount into the joiner pocket of one wing half. Use your wire or dowel to thoroughly distribute the epoxy, coating all surfaces inside the joiner pocket. Coat the root rib and one half of the wing joiner that goes into the wing. Insert the joiner in the wing. Coat the joiner pocket in the other wing half and the other end of the wing joiner. Join the wing halves together. Then, stand the wing on end with one of the wing tips resting on the floor. Use a piece of R/C foam or something similar to cushion and stabilize the wing so it won't slide around. Hold the two wing halves together with masking tape. Wipe off any excess epoxy with a paper towel dampened with denatured alcohol.



INSTALL THE FIN

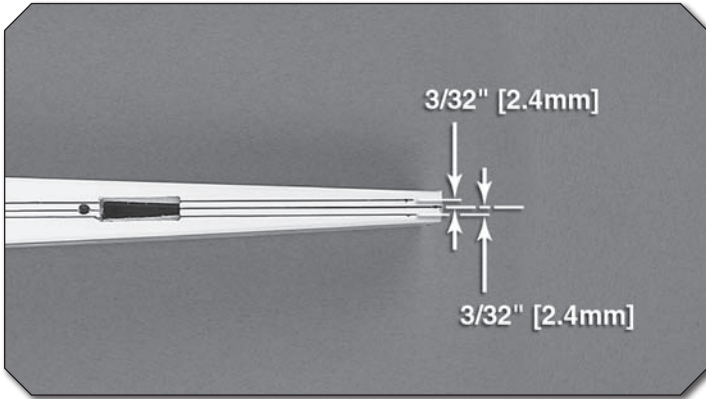

④ 1. Use a felt tip pin to draw a centerline on the top aft end of the fuselage. Draw a line $3/32"$ [2.4mm] on both sides of the centerline.

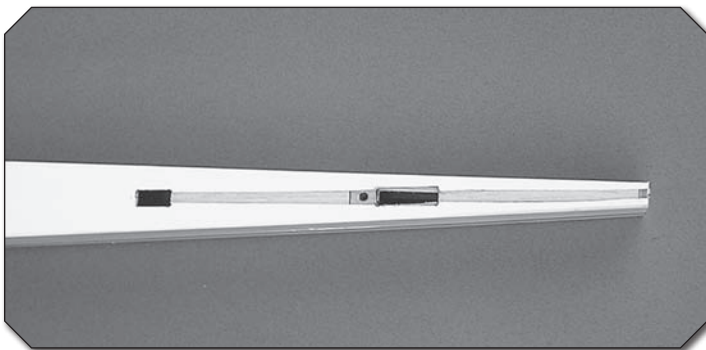

④ 2. Using a hobby knife with a fresh blade, cut and remove the covering only between the two outside lines. **DO NOT** cut the wood under the covering as this will weaken the structure.

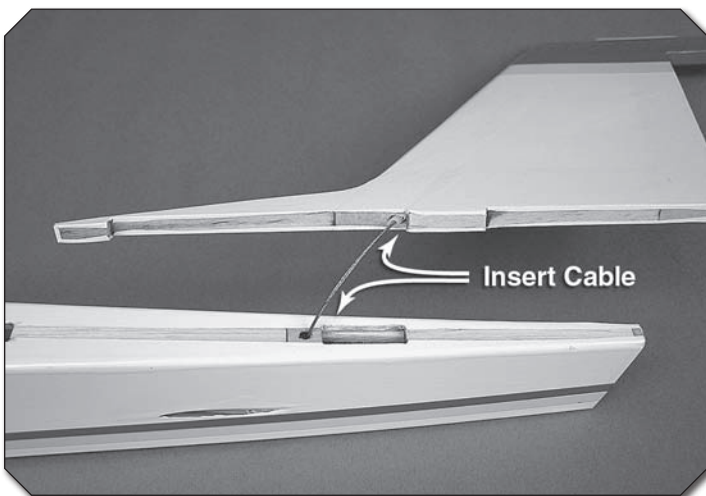

④ 3. Insert the elevator control cable into the nylon outer control tube in the fuselage and the fin. Position the fin on the fuselage and move the cable to check that it moves freely.

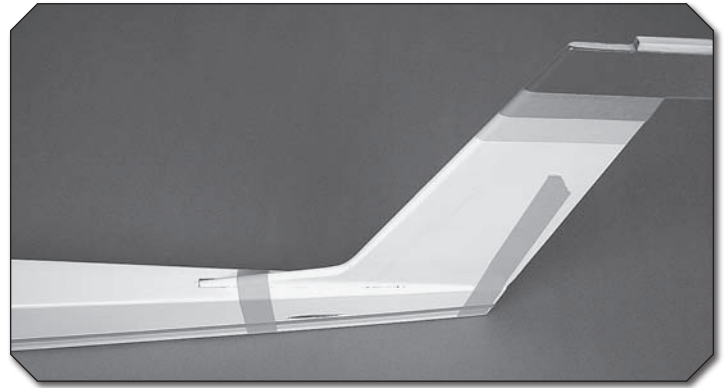

④ 4. Use 6-minute epoxy to glue the fin to the top of the fuselage. Wipe off the excess epoxy with a paper towel dampened with rubbing alcohol. Use masking tape to hold the fin in position, aligned with the centerline of the fuselage and parallel to the sides.

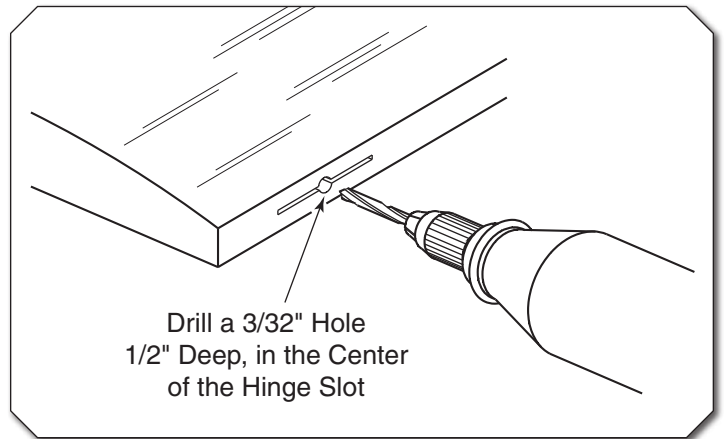

④ 5. Drill a $3/32"$ [2.4mm] hole, $1/2"$ [13mm] deep, in the center of the fin and rudder hinge slots. If you use a Dremel® Rotary Tool for this task, it will result in a cleaner hole than if you use a slower speed drill. Drilling the hole will twist some of the wood fibers into the slot, making it difficult to insert the hinge. Insert a hobby knife blade in the slot, working it back and forth a few times to clean out the slot.

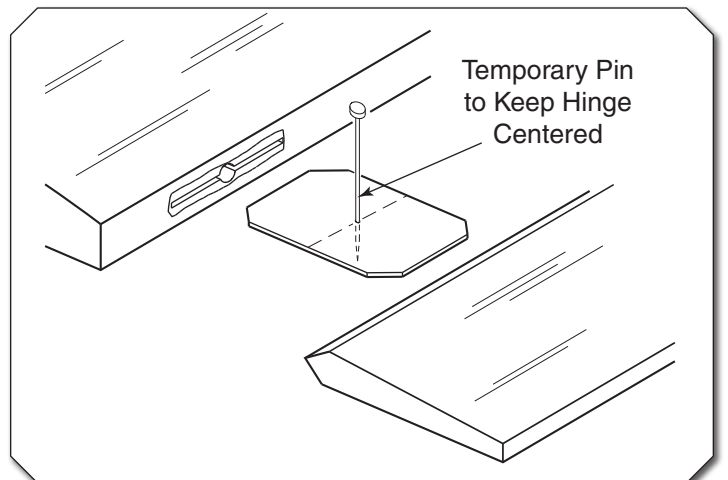

④ 6. To keep the hinges centered, insert a pin in the center of the hinges.

7. Insert three hinges in the rudder and attach the rudder to the fin. Remove the pins, making sure there is approximately a 1/64" [0.4mm] gap between the rudder and fin.

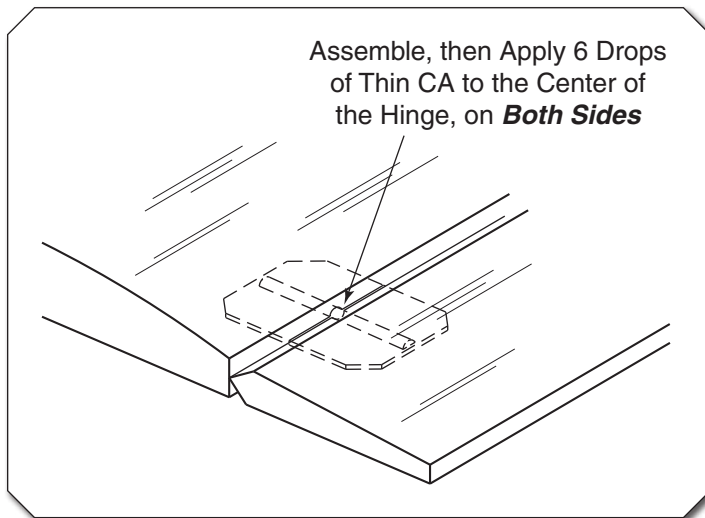

8. Deflect the rudder 1-1/2" [38mm] in one direction and apply six drops of thin CA to the center of the hinges. Deflect the rudder in the other direction and again apply six drops of thin CA to the center of the hinges. Use a paper towel to absorb excess CA from the hinge gap before it hardens. Do not use CA accelerator. Allow the CA to harden slowly.

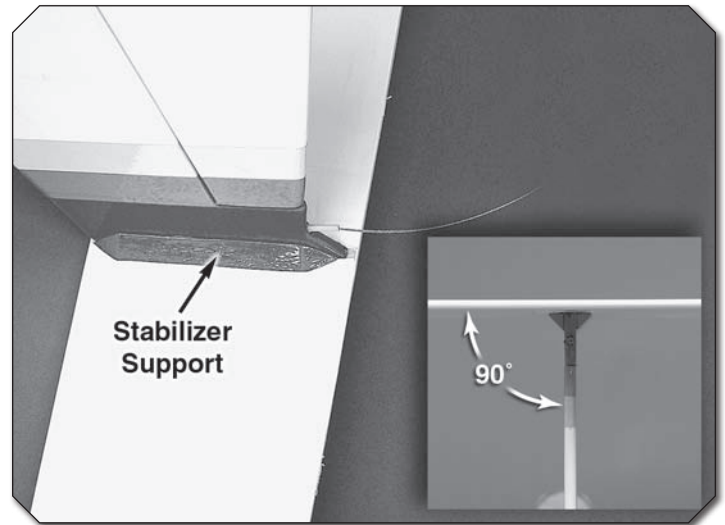

3. Position the two stabilizer supports under the stabilizer against the fin. Mark the outline of the supports on the fin and stabilizer. Use a sharp hobby knife to trim and remove the covering 1/16" [1.5mm] inside the outline.

4. Use 6-minute epoxy to glue the stabilizer supports to the fin and stabilizer.

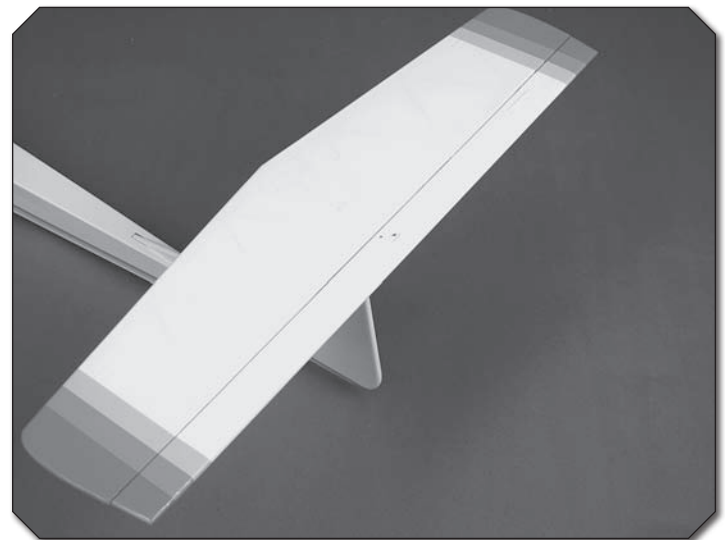

5. Install the elevator using the same hinging method used on the rudder.

CGI **INSTALL THE STABILIZER**

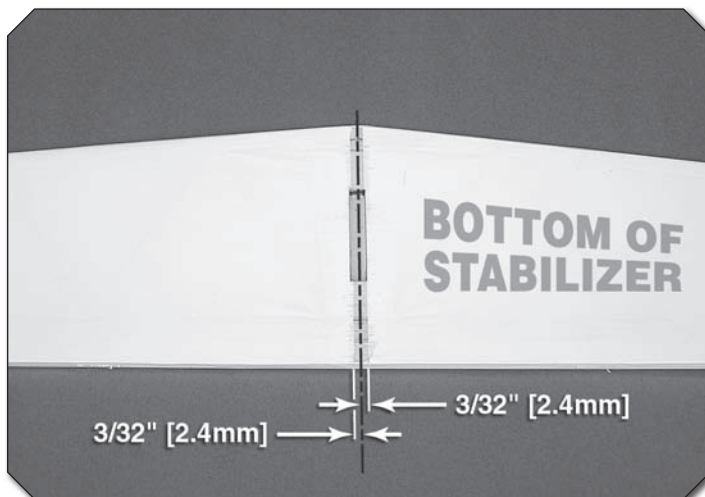

1. Draw a centerline on the bottom of the stabilizer. Draw a line 3/32" [2.4mm] on each side of the centerline. Use a hobby knife to cut and remove the covering only between the two outside lines. **DO NOT** cut the wood under the covering as this will weaken the stabilizer, causing it to fail.

2. Use 6-minute epoxy to glue the stabilizer to the top of the fin. Use a square to check that the stabilizer is perpendicular to the fin.



INSTALL THE RADIO SYSTEM

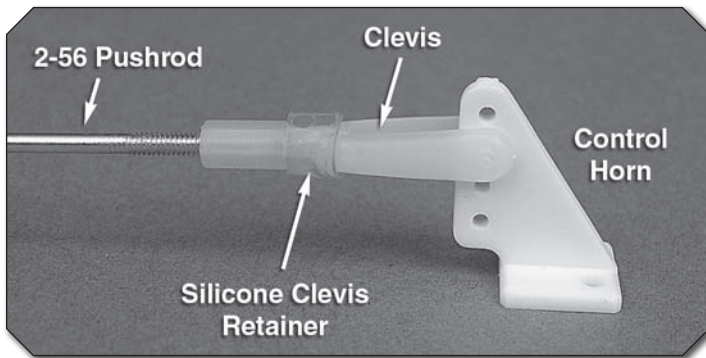

1. Cut the back plate from one of the nylon control horns. Thread a nylon clevis 14 turns onto the 2-56 metal pushrod. Slide a silicone clevis retainer over the end of the clevis. Attach the clevis in the third hole from the bottom of the control horn.

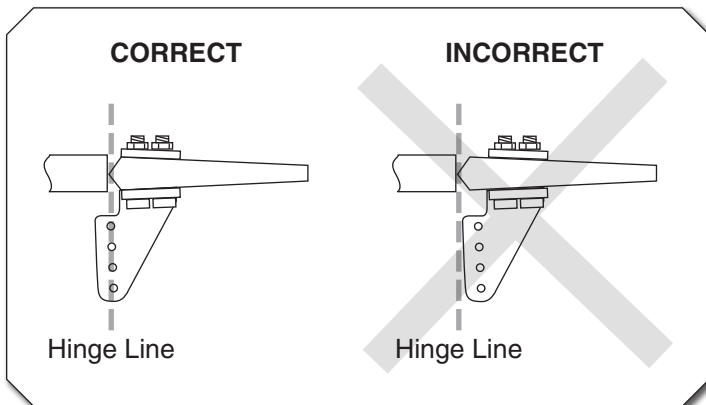

2. Use a sharp hobby knife to remove the covering from the end of the rudder guide tube. Insert the pushrod into the rudder pushrod guide tube. Position the control horn on the rudder so that the four holes in the control horn are aligned with the hinge line. Drill two 3/32" [2.4mm] holes through the rudder using the control horn as a guide. Remove the control horn and harden the holes by applying two or three drops of thin CA in each hole. After the CA has cured, attach the control horn to the rudder using two 2-56 x 3/8" [9.5mm] screws and the control horn back plate.

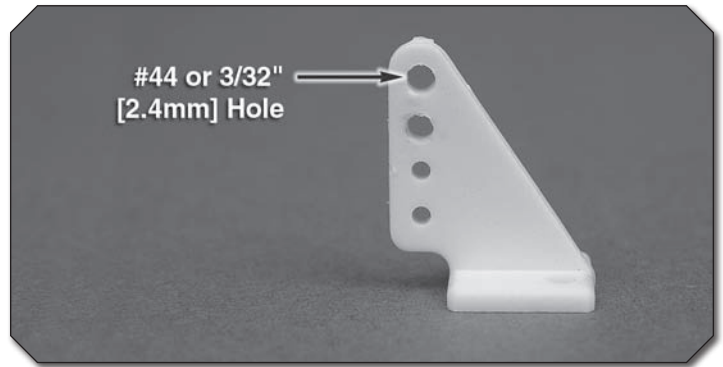

3. Use a #44 or 3/32" [2.4mm] drill bit to enlarge the outer hole in the second nylon control horn.

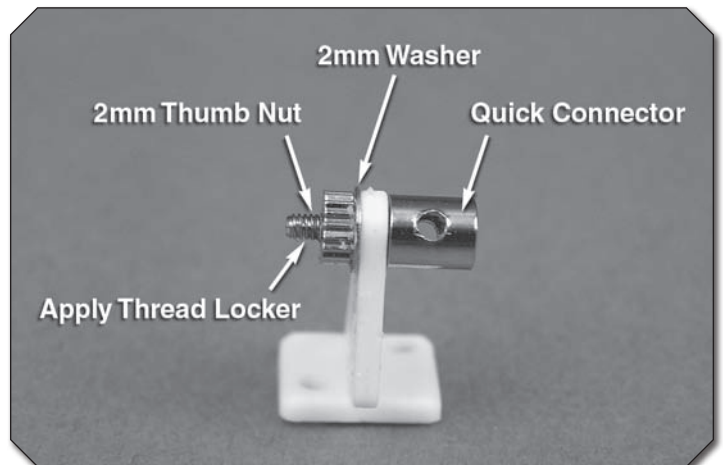

4. Insert the quick connector through the previously drilled hole in the control horn. Install a 2mm washer on the quick connector. Put a drop of threadlocker on the threads and secure the quick connector with a 2mm thumb nut. Tighten the nut and then slowly back it off until the quick connector rotates freely. The threadlocker will prevent the nut from coming loose.

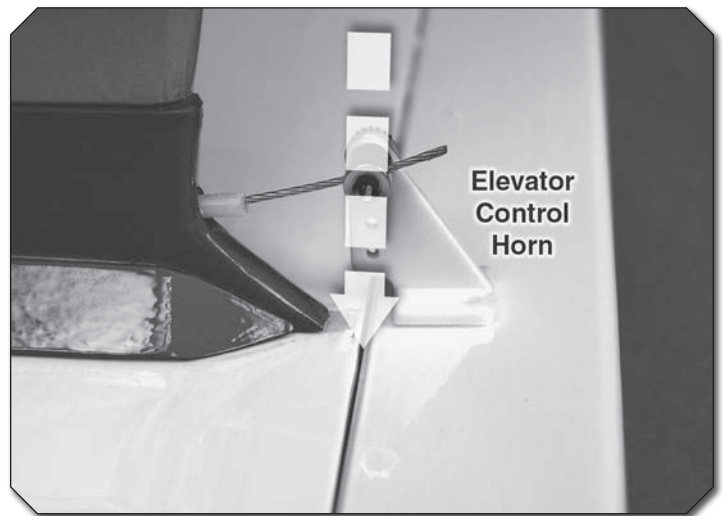

5. Slide the elevator cable through the hole in the quick connector and position the elevator control horn so that the four holes are aligned with the elevator hinge line. Use a felt tipped pen to mark the location of the holes.



6. Drill two 3/32" [2.4mm] holes through the elevator using the control horn as a guide. Remove the control horn and harden the holes by applying two or three drops of thin CA in each hole. After the CA has hardened, attach the control horn to the elevator using two 2-56 x 3/8" [9.5mm] screws and the control horn back plate.

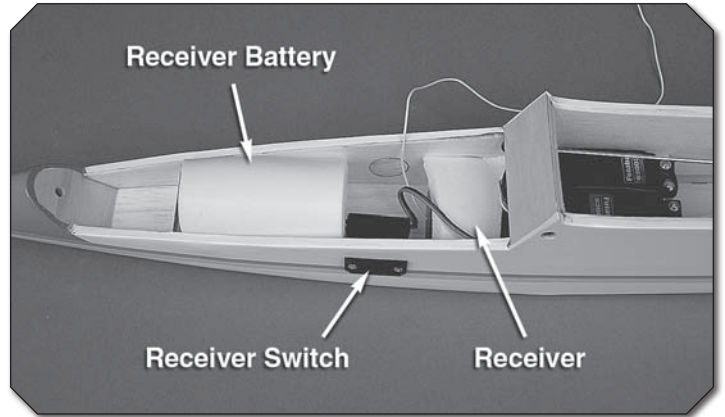

8. Wrap the receiver and receiver battery in 1/4" [6.4mm] thick foam. Position the receiver and receiver battery in the fuselage as shown. Remove the receiver switch cover from the receiver switch. Position the switch cover on the outside of the fuselage, between the receiver and receiver battery. Mark the two mounting screw holes and the switch opening on the fuselage. Use a sharp hobby knife to cut out the switch opening and a 3/32" [2.4mm] drill bit to drill out the screw holes. Mount the receiver switch on the inside of the fuselage with the switch cover on the outside.

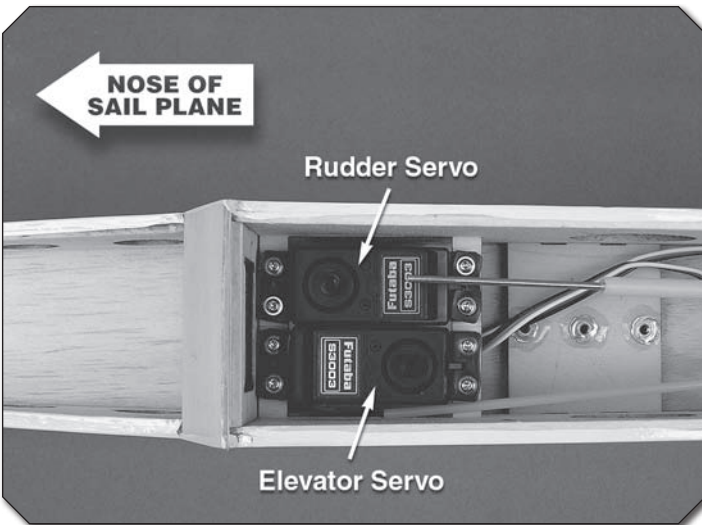
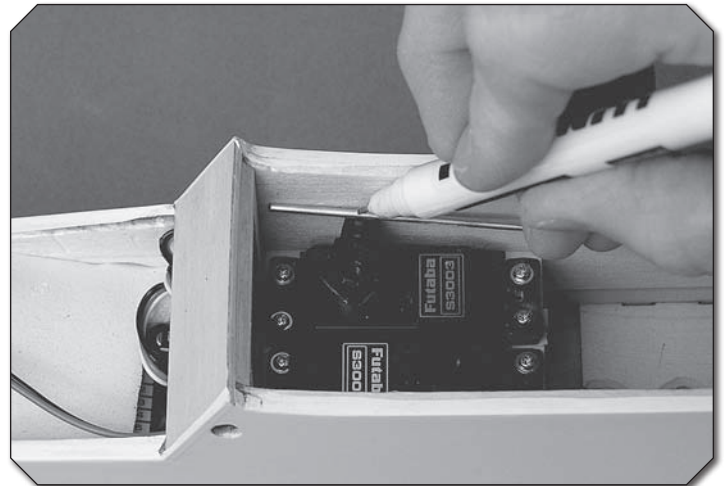
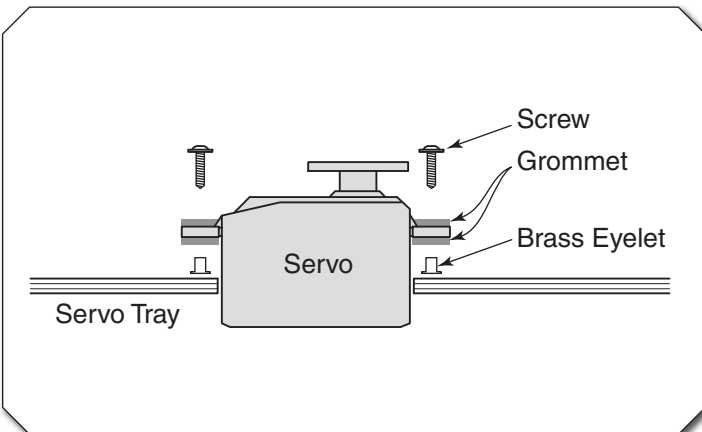

7. Install the servos using the hardware included with your radio system. Again, apply a couple of drops of thin CA to harden the screw holes.

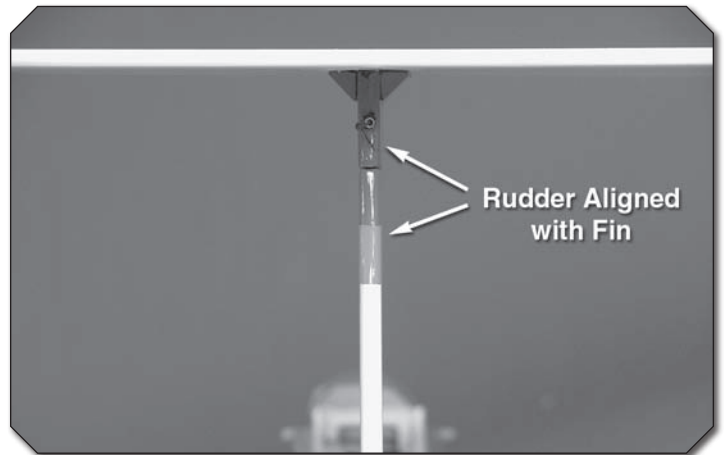

9. Switch on the transmitter and receiver. Center the elevator and rudder trims on the transmitter. Remove the servo arm screw and position the servo arm so that it is

perpendicular to the centerline of the servo. Cut the servo arm so it does not touch the fuselage side approximately 7/16" [11.1mm] from the center of the arm. Remove the unused arms and reinstall the servo arm. Reinstall the servo arm screw. With the rudder centered, rudder is aligned with the fin, mark the pushrod wire at the servo arm.

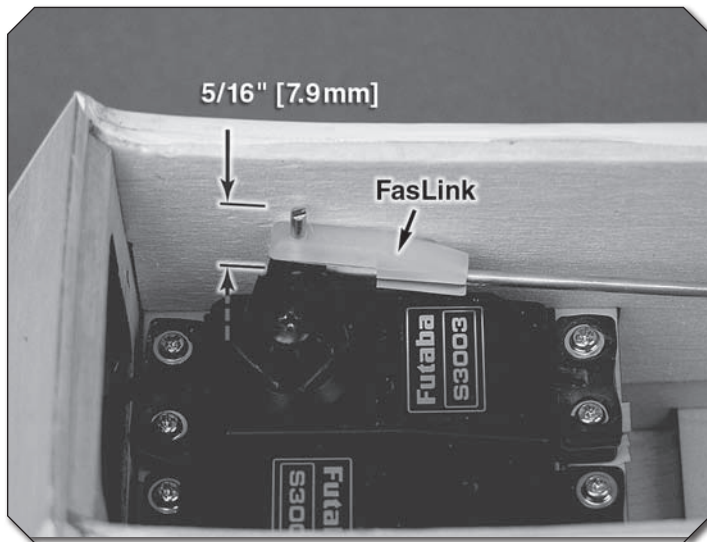

10. Bend the wire up at the mark. Cut the wire 5/16" [7.9mm] above the bend. Secure the pushrod to the servo arm with a nylon FasLink™. Make sure the FasLink does not hit the fuselage side or bind against the servo arm.

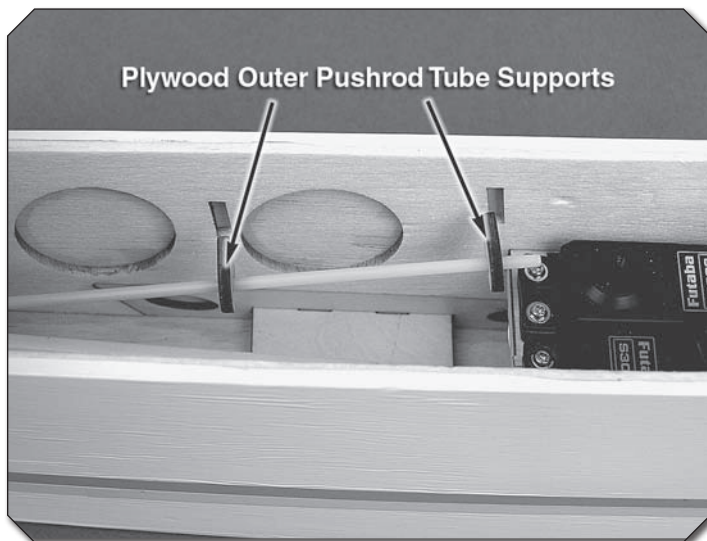

11. Slide the two plywood outer pushrod tube supports over the elevator outer pushrod tube.

12. Center the elevator servo. Trim a servo arm to fit perpendicular to the elevator servo. Remove the other unused servo arms.

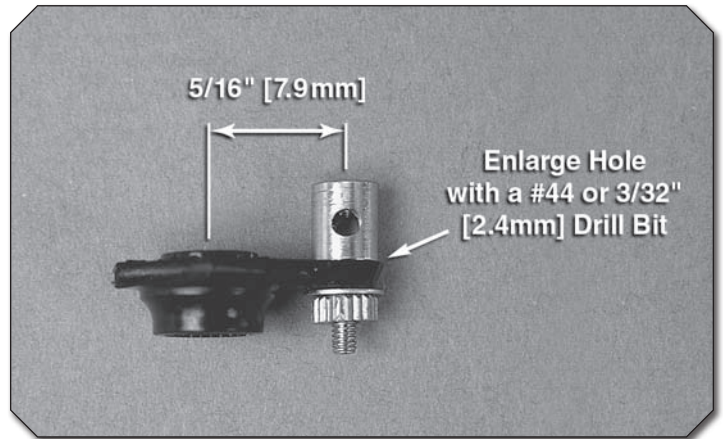

13. Install a quick connector on the elevator servo arm following the same procedure used to install it on the elevator control horn.



14. Install the servo arm on the elevator servo. Route the elevator cable through the quick connector on the elevator control horn and the elevator servo arm. Apply a drop of threadlocker on a 3x 5mm machine screw. Install the machine screw in the quick connector on the elevator control horn and tighten it against the elevator cable.



15. Use CA to glue the two plywood elevator outer tube supports in the slots in the fuselage side.

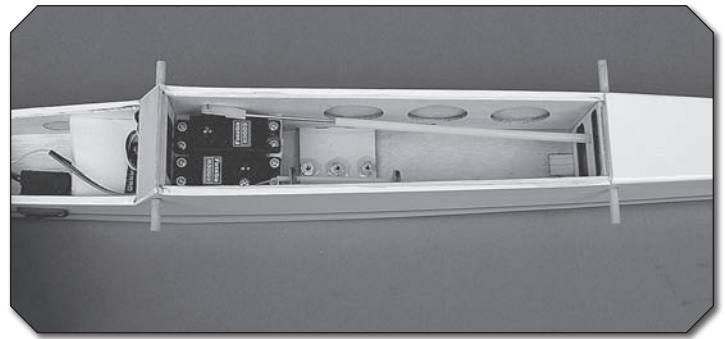
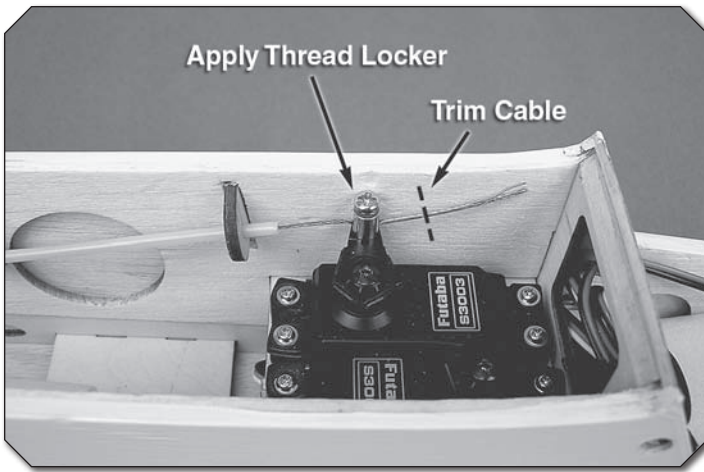

2. Remove the covering from over the wing dowel holes. Center the wing dowels in the fuselage. Use thin CA to glue them in position.

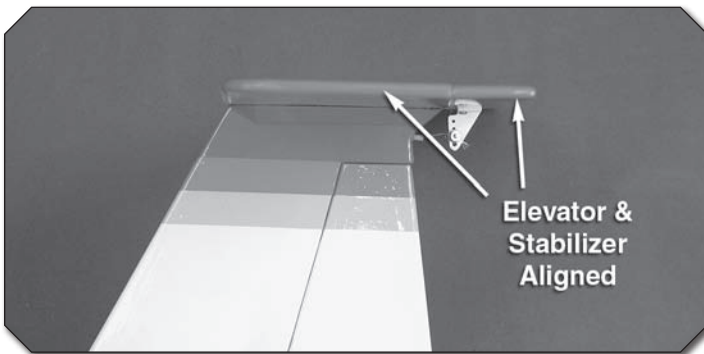

CANOPY INSTALLATION

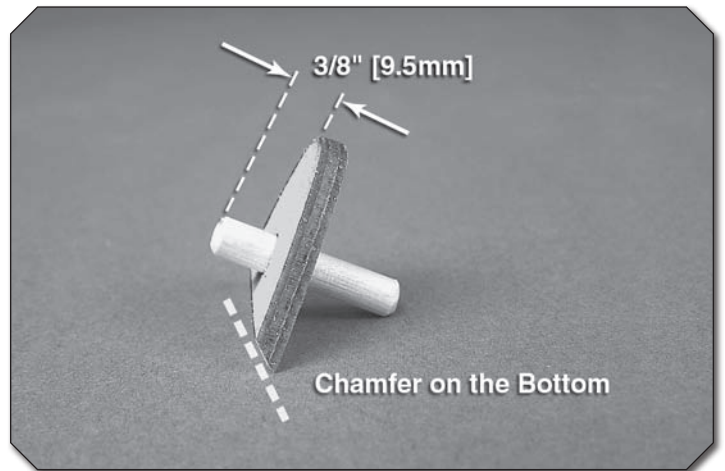

16. Center the elevator servo arm and the elevator. Apply a drop of threadlocker on a 3x 5mm machine screw. Install the machine screw in the quick connector on the elevator servo arm and tighten it against the elevator cable. Trim off the excess cable.

1. Use thin CA to glue the small hardwood dowel into the front canopy brace so that it protrudes out approximately 3/8" [9.5mm].

17. Route the receiver antenna under the servos and to the back of the wing saddle. Insert the antenna in the provided antenna tube inside the aft end of the fuselage.

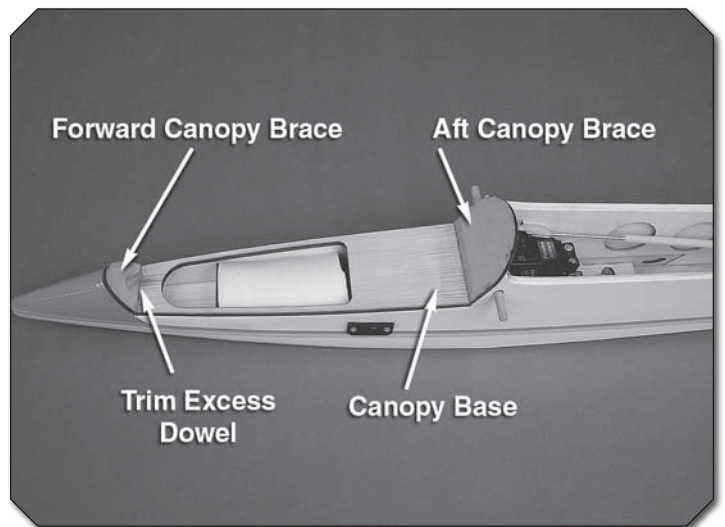

2. Place a piece of wax paper in the cockpit opening. Center the canopy base on the fuselage. Insert the dowel in the front canopy base into the fuselage and position the aft canopy brace, centered on the canopy base. Use medium CA to glue the forward and aft canopy braces to the canopy base.

1. Use 6-minute epoxy to glue the nylon tail skid on the aft bottom of the fuselage.

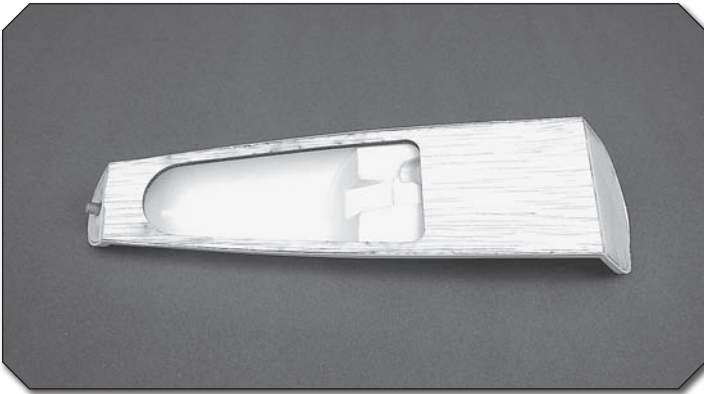

3. Use CA to glue the plastic cockpit to the canopy braces and base. Trim the cockpit so that it is flush with the canopy braces and base.

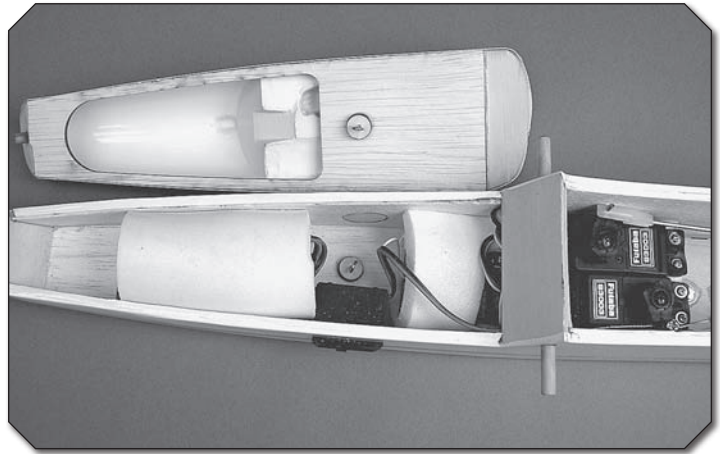

6. Use medium CA to glue one of the eyelets to the bottom of the fuselage between the receiver and receiver battery. Glue the second eyelet on the bottom of the cockpit aligned with the eyelet in the fuselage. After the CA has hardened, thread the eyelets in three or four turns more.

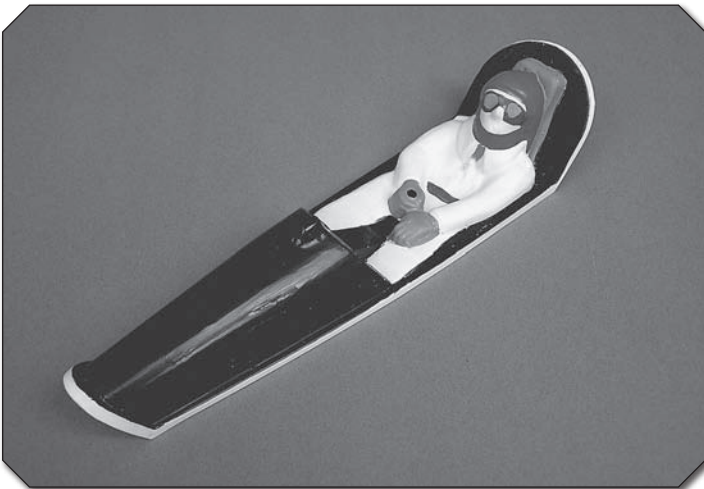

4. Paint the cockpit with the color scheme of your choice. Test the paint on a piece of plastic that was cut off of the cockpit to make sure it will not affect the plastic. RC car paints usually work well for this. Do not paint the edges of the cockpit where the canopy will attach or the glue will not hold as well. After the canopy is glued on, the canopy frame decal will cover the glue joint. After the paint has dried, apply the instrument decal to the instrument panel.

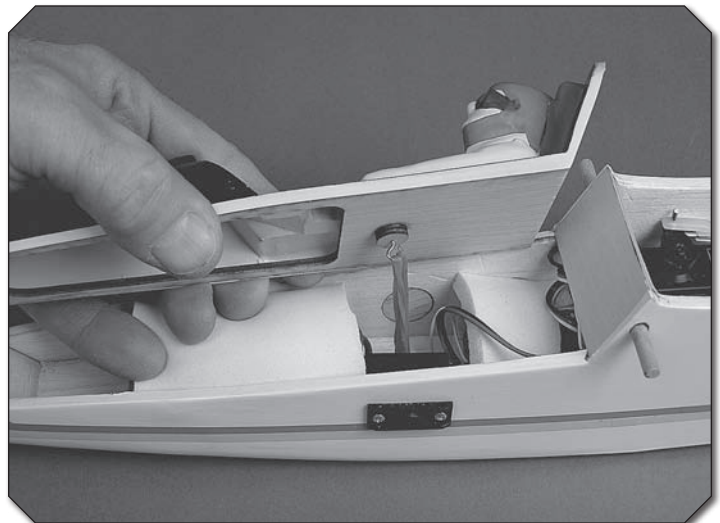

7. Attach one of the rubberbands to the eyelets. It will have to be doubled or tripled to create enough tension to hold the back of the cockpit against the fuselage.

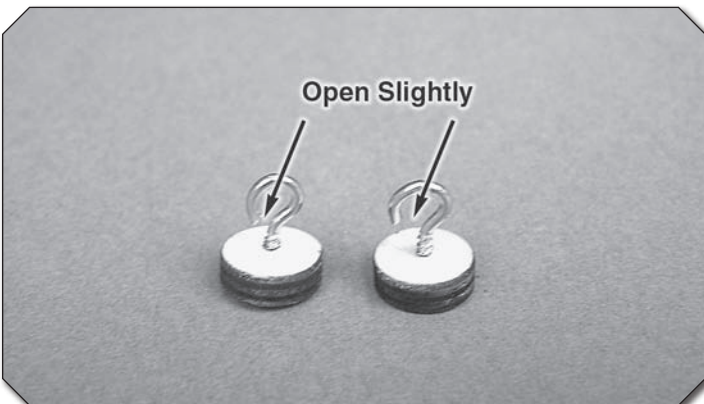

5. Using a needle nose pliers, open the eyelet slightly so that a rubberband can be installed on the eyelet. Thread each eyelet into the round plywood doubler until it just starts to come out the back.

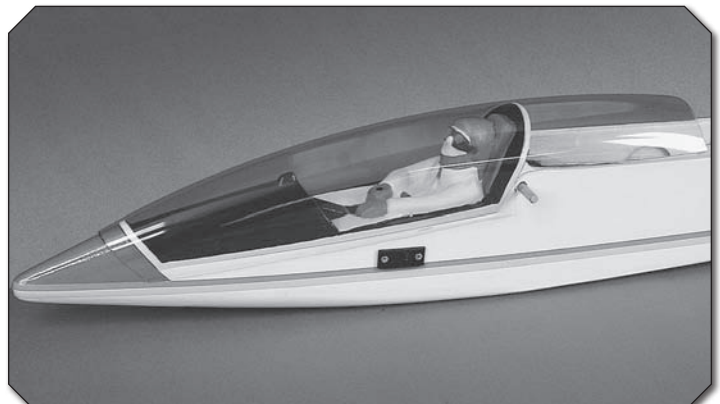

8. Trim the canopy 1/4" [6.4mm] outside the scribe lines. Set the canopy over the cockpit and mark the outline of the cockpit on the canopy. Trim the canopy to the line.



9. Remove the canopy and the cockpit from the fuselage. Glue the cockpit between the lines on the canopy using canopy glue such as J&Z R/C-56 Glue, Pacer RIC 560 Canopy Glue or 6-minute epoxy. Use the glue sparingly.

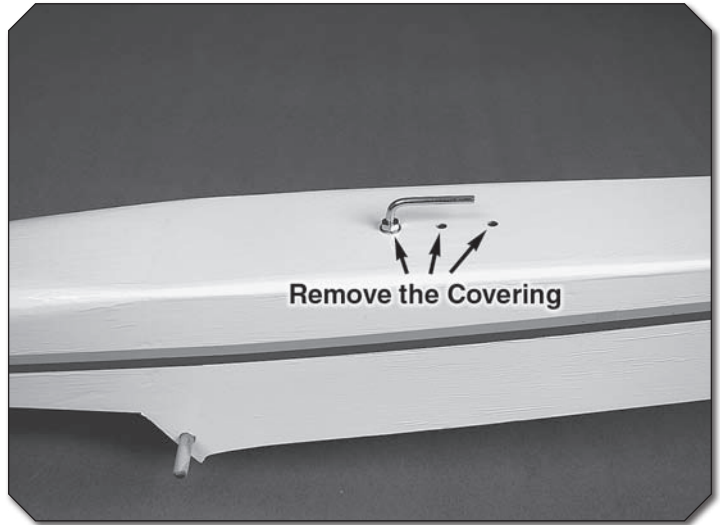

12. Attach the threaded tow hook to the bottom of the fuselage by threading a 3mm nut and a 3mm washer all the way onto the tow hook. Apply a drop of threadlocker to the threads and tighten the tow hook into the front blind nut for the first flights. With the tow hook threaded almost all the way into the blind nut, make sure the tow hook is facing straight back and tighten the 3mm nut to secure it. After the first flights the tow hook can be moved back to the center hole for most flying conditions. For contest flying, you may want to try the rear hole as it can help achieve a higher launch but be careful as the sailplane will be more aft to “pop-off” the line.

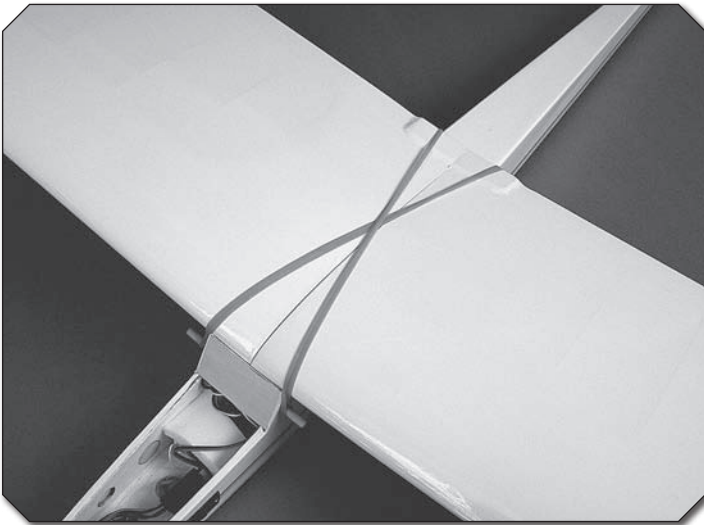

10. Remove the canopy and install the wing. Only a couple of large rubberbands are needed to hold the wing at this time. You will need to use at least eight rubber bands for flying.

APPLY THE DECALS

1. Use scissors or a sharp hobby knife to cut the decals from the sheet.

2. Be certain the model is clean and free from oily fingerprints and dust. Prepare a dishpan or small bucket with a mixture of liquid dish soap and warm water—about one teaspoon of soap per gallon of water. Submerge the decal in the soap and water and peel off the paper backing. **Note:** Even though the decals have a “sticky-back” and are not the water transfer type, submersing them in soap & water allows accurate positioning and reduces air bubbles underneath.

3. Position decal on the model where desired. Holding the decal down, use a paper towel to wipe most of the water away.

4. Use a piece of soft balsa or something similar to squeegee remaining water from under the decal. Apply the rest of the decals the same way.

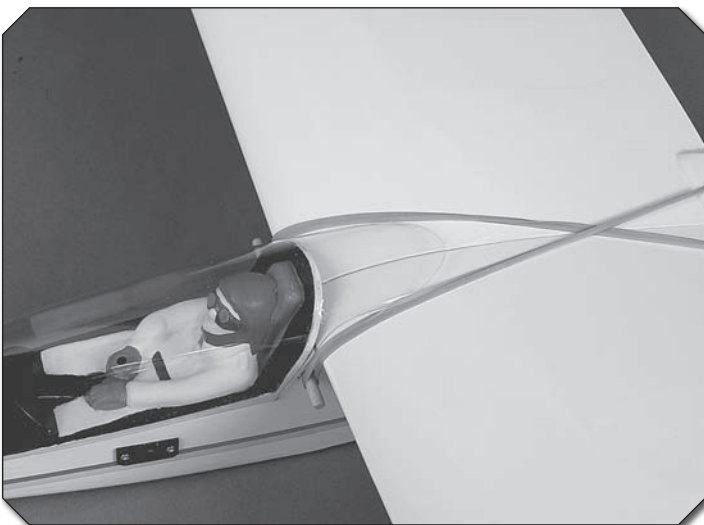

11. Trim the aft end of the canopy to follow the shape of the wing.



GET THE MODEL READY TO FLY

CHECK THE CONTROL DIRECTIONS

1. Turn on the transmitter and receiver and center the trims. If necessary, remove the servo arms from the servos and reposition them so they are centered. Reinstall the screws that hold on the servo arms.

2. With the transmitter and receiver still on, check all the control surfaces to see if they are centered. If necessary, adjust the clevises on the pushrods to center the control surfaces.

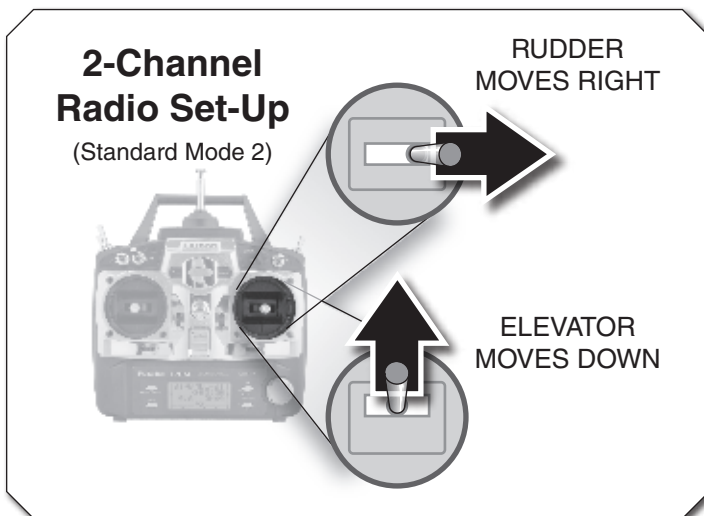

3. Make certain that the control surfaces respond in the correct direction as shown in the diagram. If any of the controls respond in the wrong direction, use the servo reversing in the transmitter to reverse the servos connected to those controls. Be certain the control surfaces have remained centered. Adjust if necessary.

SET THE CONTROL THROWS

To ensure a successful first flight, set up your Sophisticated Lady according to the control throws specified in this manual. The throws have been determined through actual flight testing and accurate record-keeping allowing the model to perform in the manner in which it was intended. If, after you have become accustomed to the way the Sophisticated Lady flies, you would like to change the throws to suit your taste, that is fine. However, too much control throw could make the model too responsive and difficult to control, so remember, "more is not always better."

1. Use an airplane stand or something similar to raise up the fuselage so the horizontal stab is level.

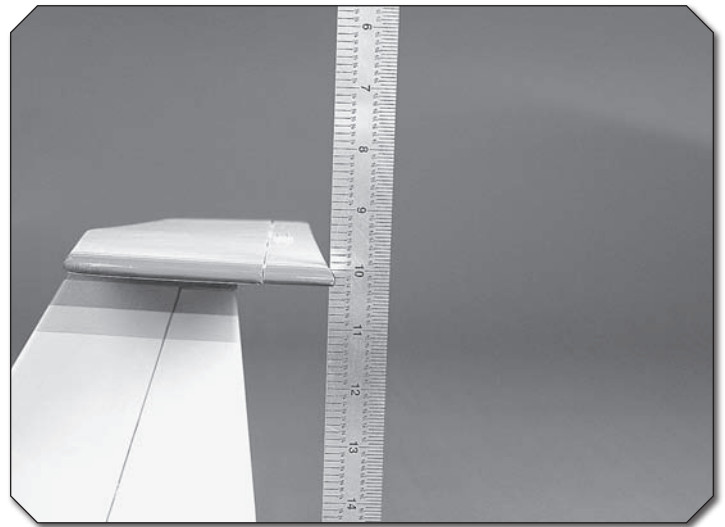

2. Measure the high rate elevator throw first. Hold a ruler vertically on your workbench against the trailing edge of the elevator. Note the measurement on the ruler.



3. Move the elevator up with your transmitter and move the ruler forward so it will remain contacting the trailing edge. The distance the elevator moves up from center is the "up" elevator throw. Measure the down elevator throw the same way.

At the Servos

The pushrod farther out means **More Throw**

The pushrod closer in means **Less Throw**

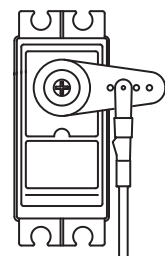
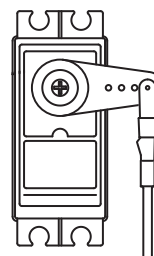

At the Control Surfaces

The pushrod farther out means **Less Throw** The pushrod closer in means **More Throw**

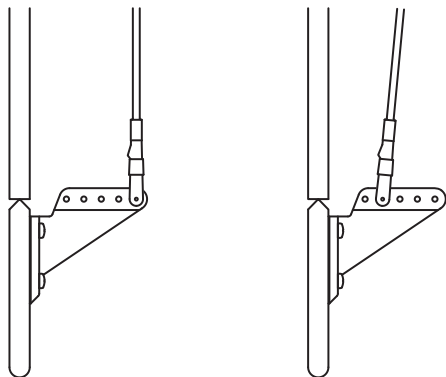

4. If necessary, adjust the location of the pushrod on the servo arm or on the elevator horn, or program the ATVs in your transmitter to increase or decrease the throw according to the measurements in the control throws chart.

5. Measure and set the **low rate** elevator throws and the high and low rate throws for the rudder control surface the same way.

If your radio does not have dual rates, we recommend setting the throws at the high rate settings.

NOTE: The throws are measured at the **widest part** of the elevator and rudder.

BALANCE THE MODEL (C.G.)

More than any other factor, the C.G. (center of gravity/ balance point) can have the greatest effect on how a model flies and could determine whether or not your first flight will be successful. If you value your model and wish to enjoy it for many flights, **DO NOT OVERLOOK THIS IMPORTANT PROCEDURE.** A model that is not properly balanced may be unstable and possibly unflyable.

At this stage the model should be in ready-to-fly condition with **all** of the components in place including the complete radio system.

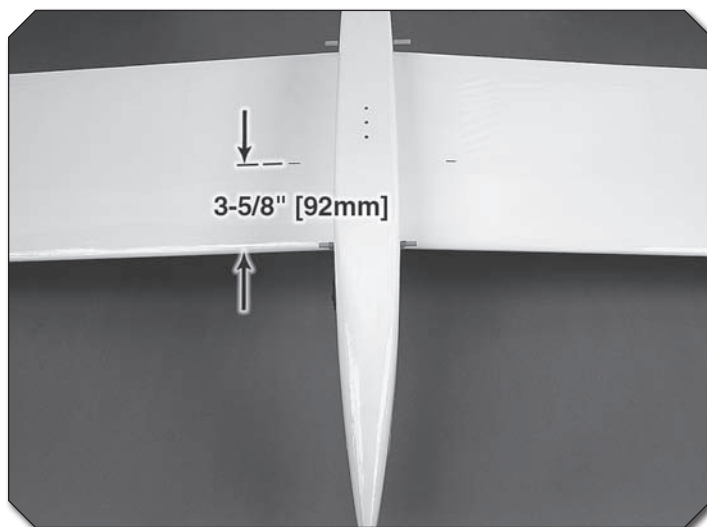

1. If using a Great Planes C.G. Machine, set the rulers to 3-5/8" [92mm]. If not using a C.G. Machine, use a fine-point felt tip pen to mark lines on the bottom of the wing on both sides of the fuselage 3-5/8" [92mm] back from the leading edge. Apply narrow (1/16" [2mm]) strips of tape over the lines so you will be able to feel them when lifting the model with your fingers.

This is where your model should balance for the first flights. Later, you may experiment by shifting the C.G. 1/8" [3mm] forward or 1/8" [3mm] back to change the flying characteristics. Moving the C.G. forward will improve the smoothness and stability, but the model will then be less sensitive (which may be fine for less-experienced pilots). Moving the C.G. aft makes the model more maneuverable and improves the sailplanes response to air currents. In any case, **start at the recommended balance point** and do not at any time balance the model outside the specified range.

These are the recommended control surface throws:

	HIGH RATE		LOW RATE	
ELEVATOR	Up	Down	Up	Down
	3/8" [9.5mm]	3/8" [9.5mm]	3/16" [4.8mm]	3/16" [4.8mm]
	22 deg	22 deg	11 deg	11 deg
RUDDER	Right	Left	Right	Left
	1-1/2" [38mm]	1-1/2" [38mm]	1" [25.4mm]	1" [25.4mm]
	24 deg	24 deg	16 deg	16 deg

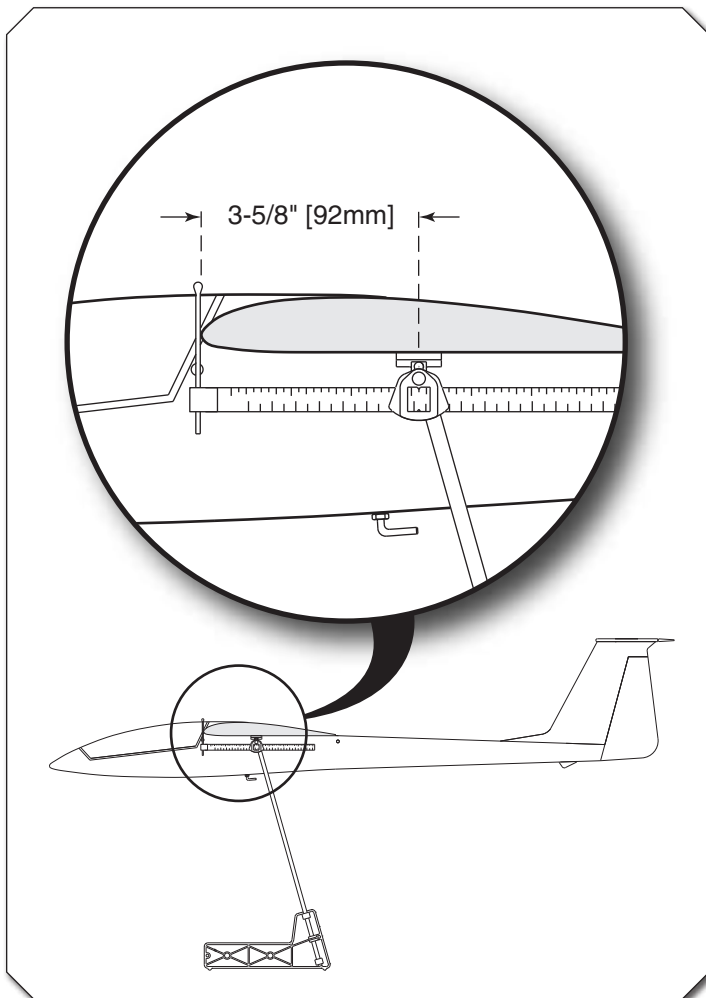

2. With the wing attached to the fuselage, and all parts of the model installed (ready to fly), place the model right side up on a Great Planes CG Machine, or lift it at the balance point you marked.

3. If the tail drops, the model is “tail heavy.” Weight will need to be added to the nose to get the model to balance. If the nose drops, the model is “nose heavy.” If needed, the receiver and receiver battery can be moved aft of the servos. If weight is required use Great Planes “stick-on” lead (GPMQ4485). To find out how much weight is required, place incrementally increasing amounts of weight on the top of the fuselage over the location where it would be mounted inside until the model balances. The Sophisticated Lady has a weight compartment in the nose where lead or BBs can be added. Once the amount of weight that is required in the nose is determined, the BBs can be glued in using white glue.

4. **IMPORTANT:** If you found it necessary to add any weight, recheck the C.G. after the weight has been installed.

BALANCE THE MODEL Laterally

1. With the wing level, have an assistant help you lift the model by the nose and the bottom of the fuse under the TE of the fin. Do this several times.

2. If one wing always drops when you lift the model, it means that side is heavy. Balance the airplane by adding weight to the other wing tip. **An airplane that has been laterally balanced will track better.**



CHECKING FOR WARPS

This is a very important step and should be done occasionally throughout the flying season. A sailplane’s wing is most efficient when it is not twisted or warped at all. “Washout” (the wings trailing edges are twisted up at the tips) helps make a poor wing design fly better by adding some stability (preventing stalls) at slow speeds but it cuts down on the wing’s efficiency at normal speeds. The Sophisticated Lady ARF’s wing is designed to fly well at slow speeds without any washout, and therefore we recommend you check to make sure the wings are “flat” using the following procedure:

Set the wing so an inner panel is resting on a flat surface. Any warp (twist) will show up by causing a corner of the panel to rise off the work surface.

To remove the warp, gently twist the wing in the opposite direction while a helper glides an iron or heat gun over the covering on both the top and the bottom of the panel to re-shrink the covering. Hold the twist until the covering cools and then recheck for warps. It may take several tries to get a warp out, but it is worth it as you will end up with a sailplane that flies straight and true and responds to air currents like a high performance sailplane should.

Follow the same procedure to check all four wing panels and then go back and double check them. Sometimes you put a warp in one wing panel while trying to fix another. You should also look at the tail surfaces as they too can warp.



PREFLIGHT

IDENTIFY YOUR MODEL

No matter if you fly at an AMA sanctioned R/C club site or if you fly somewhere on your own, you should always have your name, address, telephone number and AMA number on or inside your model. It is **required** at all AMA R/C club flying sites and AMA sanctioned flying events. Fill out the identification tag on page 18 and place it on or inside your model.

CHARGE THE BATTERIES

Follow the battery charging instructions that came with your radio control system to charge the batteries. You should always charge your transmitter and receiver batteries the night before you go flying, and at other times as recommended by the radio manufacturer.

CAUTION: Unless the instructions that came with your radio system state differently, the **initial** charge on **new** transmitter and receiver batteries should be done for 15 hours **using the slow-charger that came with the radio system**. This will “condition” the batteries so that the next charge may be done using the fast-charger of your choice. If the initial charge is done with a fast-charger the batteries may not reach their full capacity and you may be flying with batteries that are only partially charged.

GROUND CHECK AND RANGE CHECK

Always ground check the operational range of your radio before the first flight of the day following the manufacturer’s instructions that came with your radio. If the control surfaces do not respond correctly, **do not fly!** Find and correct the problem first. Look for loose servo connections or broken wires, corroded wires on old servo connectors, poor solder joints in your battery pack or a defective cell, or a damaged receiver crystal from a previous crash.



AMA SAFETY CODE (EXCERPTS)

Read and abide by the following excerpts from the Academy of Model Aeronautics Safety Code. For the complete Safety Code refer to *Model Aviation* magazine, the AMA web site or the Code that came with your AMA license.

GENERAL

- 1) I will not fly my model aircraft in sanctioned events, air shows, or model flying demonstrations until it has been proven to be airworthy by having been previously, successfully flight tested.
- 2) I will not fly my model aircraft higher than approximately 400 feet [122m] within 3 miles [4.8km] of an airport without notifying the airport operator. I will give right-of-way and avoid flying in the proximity of full-scale aircraft. Where necessary, an observer shall be utilized to supervise flying to avoid having models fly in the proximity of full-scale aircraft.
- 3) Where established, I will abide by the safety rules for the flying site I use, and I will not willfully and deliberately fly my models in a careless, reckless and/or dangerous manner.
- 5) I will not fly my model unless it is identified with my name and address or AMA number, on or in the model. Note: This does not apply to models while being flown indoors.
- 7) I will not operate models with pyrotechnics (any device that explodes, burns, or propels a projectile of any kind).

RADIO CONTROL

- 1) I will have completed a successful radio equipment ground check before the first flight of a new or repaired model.

- 2) I will not fly my model aircraft in the presence of spectators until I become a qualified flier, unless assisted by an experienced helper.
- 3) At all flying sites a straight or curved line(s) must be established in front of which all flying takes place with the other side for spectators. Only personnel involved with flying the aircraft are allowed at or in the front of the flight line. Intentional flying behind the flight line is prohibited.
- 4) I will operate my model using only radio control frequencies currently allowed by the Federal Communications Commission.
- 5) **I will not knowingly operate my model within three miles of any pre-existing flying site except in accordance with the frequency sharing agreement listed [in the complete AMA Safety Code].**



CHECK LIST

During the last few moments of preparation your mind may be elsewhere anticipating the excitement of the first flight. Because of this, you may be more likely to overlook certain checks and procedures that should be performed before the model is flown. To help avoid this, a check list is provided to make sure these important areas are not overlooked. Many are covered in the instruction manual, so where appropriate, refer to the manual for complete instructions. Be sure to check the items off as they are completed (that’s why it’s called a *check list!*).

1. Check the C.G. according to the measurements provided in the manual.
2. Extend your receiver antenna and make sure it has a strain relief inside the fuselage to keep tension off the solder joint inside the receiver.
3. Balance your model *laterally* as explained in the instructions.
4. Use threadlocking compound to secure critical fasteners such as the tow hook.
5. Make sure all hinges are **securely** glued in place.
6. Reinforce holes for wood screws with thin CA where appropriate (servo mounting screws, control horn screws, etc.).
7. Confirm that all controls operate in the correct direction and the throws are set up according to the manual.
8. Make sure there are silicone retainers on all the clevises and that all servo arms are secured to the servos with the screws included with your radio.
9. Make sure any servo leads do not interfere with other systems (servo arms, pushrods, etc.).
10. Place your name, address, AMA number and telephone number on or inside your model.

- ⦿ 11. Cycle your receiver battery pack (if necessary) and make sure it is fully charged.
- ⦿ 12. If you wish to photograph your model, do so before your first flight.
- ⦿ 13. Range check your radio when you get to the flying field.



MOUNT THE WING

Mount the wing to the fuselage with included eight #64 rubber bands. Install them from front to back, crisscrossing the last two. Never use torn or cracked rubber bands. After removing the rubber bands from your model, store them in a container with talcum powder or clay-type kitty litter to keep them fresh for the next flying session.

If the rubber bands you will be using are different from those recommended, consult an experienced modeler to make certain they are strong enough, and that you have used enough of them. If uncertain, force the front of the wing off of the wing saddle. There should be considerable resistance! If the wing can be forced from the fuselage without having to strain your hands, then there are probably not enough rubber bands.

IMPORTANT: Flying a model with too few rubber bands can be dangerous. If the wing momentarily lifts from the fuselage and acts as though a large amount of “up” elevator has suddenly been applied because there are not enough rubber bands or they are too weak, internal structural damage may result. Even worse, the wing could actually detach from the fuselage resulting in a crash. If the model exhibits any tendencies that indicate there are not enough rubber bands, immediately land and closely inspect the model for damage. If no damage is found, add more rubber bands.

If you are flying with other flyers check to make sure they are not flying or testing on the same frequency as your model.

If you are an inexperienced pilot try to find an experienced pilot to help you with your first flights. Although the Sophisticated Lady is very easy to fly, an experienced pilot can save you a lot of time and possible aggravation by helping you get your model in the air smoothly.

CAUTION (THIS APPLIES TO ALL R/C AIRPLANES):

If, while flying, you notice an alarming or unusual sound such as a low-pitched “buzz,” this may indicate control surface *flutter*. Flutter occurs when a control surface (such as an aileron or elevator) or a flying surface (such as a wing or stab) rapidly vibrates up and down (thus causing the noise). In extreme cases, if not detected immediately, flutter can actually cause the control surface to detach or the flying surface to fail, thus causing loss of control followed by an impending crash. The best thing to do when flutter is detected is to slow the model **immediately**, then land as soon as safely possible. Identify which surface fluttered (so the problem may be resolved) by checking all the servo grommets for deterioration or signs of vibration. Make certain all pushrod linkages are secure and free of play. If it fluttered once, under similar circumstances it will probably flutter again unless the problem is fixed. Some things which can cause flutter are; Excessive hinge gap; Not mounting control horns solidly; Poor fit of clevis pin in horn; Side-play of wire pushrods caused by large bends; Excessive free play in servo gears; Insecure servo mounting.

TRIM FLIGHTS

It is a good idea to do a couple of trim flights before each flying session to make sure the plane is still in trim and the radio is working properly. The model will survive a hard landing from 5 feet much better than it will from several hundred feet. The first few trim flights should be done over a grass field, the longer the grass the better (more cushion). If possible, have a friend hand launch the sailplane the first few trim flights. This will allow you more time to make adjustments.

Switch the transmitter on first and then the receiver. Hold the Sophisticated Lady ARF under the wing with the nose pointed slightly down and directly into the wind. It is very important that it be launched with the wings level and the nose pointed at a spot on the ground about 50 feet [15.2m] in front of you. If the sailplane is launched with the nose up or launched too hard, it will climb a few feet, stall and fall nose first straight down. With the nose pointed down slightly the sailplane will accelerate down until it picks up enough flying speed then level off and glide forward. With a little practice you will be able to launch it at just the right speed so it soars straight ahead in a long and impressive glide path. Adjust the trims on your transmitter to get the plane to fly straight ahead in a smooth glide path.

Once you get the hang of launching it you can try turning the plane during the trim flights by gently applying a “touch” of right or left rudder. You can also try “flaring” the landing by slowly applying a touch of up elevator (pull the stick back) as the plane nears the ground. The Sophisticated Lady ARF will continue to fly just a few inches off of the ground for a surprisingly long distance. It is important you don’t “over control” the model. Make any control inputs slowly and smoothly rather than moving the transmitter sticks abruptly.

YOUR FIRST HI-START LAUNCH

A hi-start is the most popular way to launch your Sophisticated Lady ARF. It consists of 25'–100' [7.6–30.5m] of rubber tubing and 200'–400' [61–121.9m] of string with a parachute or streamer at the end. One end of the rubber is staked down directly upwind of the launch point. One end of the string is attached to the other end of the rubber tubing and the end of the string with the parachute has a loop or ring and is attached to the tow hook on the sailplane.

Follow the directions that came with the hi-start and lay it out directly into the wind. Place the stake at the far **upwind** edge of the flying field so the parachute will blow back onto the flying field.

Switch on your transmitter and then the receiver and hook the parachute onto the plane's tow hook. Pull the sailplane back approximately twice as far as the rubber tubing is long (i.e., 100' [30.5m] of rubber tubing = 200' [61m] of pull back) or whatever the hi-start instructions state. A "fish scale" is handy for determining the correct amount of pull. For your first flights pull the plane back until there is approximately 8 lbs. of tension. More tension can be used after you get acquainted with the launching procedure.

Hold the plane above your head with the wings level and the nose pointed slightly up and directly into the wind. Give the plane a healthy push forward to get it flying and it will climb up like a kite. You should not have to touch the elevator during the launch but use the rudder to keep it going straight up. As the rubber tubing relaxes the plane will fly off the hi-start and the parachute will bring the end of the string back towards you. If it does not come off the high start, apply down elevator to dip the nose of the sailplane down. The ring should then come off the tow hook.

FIRST FLIGHTS

Find a BIG, OPEN field for your first flights - the bigger the better as you won't have to worry about where you need to land. Ground based objects (trees, poles, buildings, etc.) seem to attract model airplanes like a magnet. **Again, we would like to recommend that you find an experienced pilot to help you with these first flights.**

Note: You need to remember that your radio control responds as if you are sitting in the cockpit of the sailplane. When you push the transmitter stick to the right, the rudder moves to the plane's right! This means that when the plane is flying towards you it may seem like the rudder controls are reversed (when you give "right" rudder the plane turns to your left – which is the plane's "right"). It is sometimes easier to learn to fly the plane if you always face your body in the direction the plane is flying and look over your shoulder to watch the model.

Don't worry about accomplishing very much on your first flights. Use these flights to get the "feel" of the controls and the Sophisticated Lady ARF's flying characteristics. Try to keep the plane upwind and just perform some gentle "S-turns"

(always turning into the wind) until it is time to set up for landing. Have a helper adjust the trims on your transmitter, a little at a time, until the plane will fly straight and level with the transmitter sticks in their neutral positions. When it is time to land, just continue performing the gentle "S-turns" upwind and let the plane glide onto the ground. Don't worry about where the plane lands – just avoid hitting anything.

Practice flying directly into the wind, without letting the plane get off course. Then, turn and come downwind until the plane is even with you and try it again. When you are comfortable with flying directly into the wind, let the plane go past you before you start back upwind. Continue this until you can fly directly towards you from downwind without getting disoriented. At this point you can start to establish a landing pattern and bring the sailplane in for a landing from downwind. This enables the plane to be flown as slowly as possible for accurate landings.

THERMAL FLYING

Thermal soaring is one of the most intriguing of all aspects of flying and the Sophisticated Lady ARF was designed to excel at thermal soaring even in the hands of a novice. It can be hard for the average person to understand how a plane can fly for hours and gain altitude without a motor.

FACTS ABOUT THERMALS

Thermals are a natural phenomenon that happens outside, by the millions, every single day of the year. Thermals are responsible for many things including forming several types of clouds, creating breezes and the distributing plant seeds and pollen. If you have ever seen a dust devil, you have seen a thermal in action. Their swirling action is very similar to that of a tornado but of course much gentler. Most thermals have updrafts rising in the 200'–700' [61–213.4m] per minute range but they have been known to produce updrafts of over 5,000' per minute. The strong updrafts can tear apart a sailplane or carry the sailplane out of sight before the pilot can get out of the updraft.

Thermals are formed by the uneven heating of the earth and buildings, etc. by the sun. The darker colored surfaces absorb heat faster than the lighter colored surfaces which reflect a great deal of the sun's energy back into space. These darker areas (plowed fields, asphalt parking lots, tar roofs, etc.) get warmer than the lighter areas (lakes, grassy fields, forests, etc.). This causes the air above the darker areas to be warmer than the air over the lighter areas and the more buoyant warm air rises as the cooler, denser air forces its way underneath the warmer air. As this warm air is forced upward it contacts the cooler air of the higher altitudes and this large temperature difference makes the thermal rise quicker. The thermal is gradually cooled by the surrounding cooler air and its strength diminishes. Eventually the thermal stops rising and any moisture contained in the once warm air condenses, forming puffy cumulus clouds. These clouds, which mark the tops of thermals, are usually between 2000' and 5000' high.

THERMAL SOARING

It takes a lot of concentration to thermal soar effectively. A sailplane can fly along the edge of a thermal and unless the pilot is carefully watching the model he may not realize the opportunity to gain some altitude. Because most thermals are relatively small, a couple hundred feet [60m] or less at 400' [121.9m] altitude) compared to the rest of the sky, the sailplane will rarely fly directly into the thermal and start rising. Generally, the sailplane will fly into the edge or near a thermal and the effects the thermal has on the plane may be almost unnoticeable. As the sailplane approaches a thermal, the wing tip that reaches the rising air first will be lifted before the opposite wing tip. This causes the sailplane to "bank" and turn away from where we would like the sailplane to go.

When you are thermal soaring, try to fly as smooth and straight as possible. Trim the sailplane to fly in a straight line and only touch the controls when you have to. Watch the sailplane carefully and it will tell you what it is encountering.

When the sailplane flies directly into a thermal it will either start rising or stop sinking. Either case is reason enough to start circling, especially in a contest where every second counts. Fly straight ahead until you feel like you are in the strongest lift, **fly a couple of seconds farther**, so that your circle will be centered in the strongest lift, and then start circling in a fairly tight but smooth turn. When the sailplane is low the turns have to be tighter to stay in the strongest lift. As the plane gains altitude, the turns can be larger and flatter. The flatter the turn, the more efficient the plane is flying. If you see the sailplane falling off on one side of the circle, move your circle over into the stronger lift. Thermals move along with the wind so as you circle you will be swept along with it. Be careful when thermaling, that you don't get so far downwind you can't make it back to the field to land.

If the sailplane is flying along straight and all of a sudden turns, let the plane continue to bank. You may have to add some rudder to keep it banked. Continue turning until the sailplane has completed a 270 degree turn, $\frac{3}{4}$ of a circle. Straighten out the bank and fly into whatever turned the plane. If you encounter lift, and you won't every time, start circling just as you did when flying directly into a thermal.

Thermals are generated all day long, but the strongest thermals are produced when the sun is directly overhead. Some of these thermals can be very large and you may find it hard to get out of them. If you find your sailplane getting too high, don't dive the plane to get out of the lift. Sailplanes are very efficient aircraft and they will build up a lot of speed and could come apart in the rough air of a thermal. The easiest way to lose altitude is to apply full rudder and full up elevator. This will put the sailplane into a tight spin that will not over stress the airframe but it will enable it to lose altitude very quickly. This is especially helpful if the sailplane gets sucked into a cloud or it gets too high to see. The twirling action will give the sun a better chance of flashing off of the wing and catching your attention.

In a gentle thermal, when you are high enough and want to leave the thermal, add a little down trim to pick up speed and fly 90 degrees to the direction of the wind. If you are not real high and want to find another thermal, you may want to look upwind of the last thermal. The same source that generated the first thermal is probably producing another. Just watch out for "sink" which is often found behind and between thermals.

As you might expect, with all this air rising, there is also air sinking. This air is the sailplane pilot's nightmare that can really make soaring challenging. Sinking air is usually not as strong as the thermal in the same area, but can be very strong. Down drafts of many hundreds of feet (meters) per minute are common on a good soaring day. These down drafts can make a sailplane look like it is falling out of the air. Because of this, it is important that you do not let the sailplane get too far downwind.

When encountering sink, immediately turn and fly 90 degrees to the direction of the wind. Apply a little "down elevator" and pick up some speed to get out of the sink as fast as possible. Every second you stay in the sink is precious altitude lost.



POINTERS FOR CONTEST FLYING

Pay Attention: Pay close attention to the sailplanes flying before you, watch them and try to establish where and when the thermals are being formed. The thermals are often formed in cycles and are fairly regular, so if you keep track of the time intervals you will have a good idea of when and where a thermal may be generated.

Watch The Birds: Thermals suck up small insects that many birds love to eat. A bunch of swallows flying around in one area may indicate a thermal. Soaring birds such as hawks, vultures and eagles are the best thermal indicators. They not only show you where the thermal is but they also show you where the center is. These "Masters of the sky" will often fly right along with the sailplanes.

Practice Those Landings: Most thermal contests are won or lost during the landing. Establish a particular landing pattern and try to stick to it for all landings. Learn to shift your pattern to account for the wind and particular fly field characteristics.

Concentrate: Keep your eye on your sailplane during your contest flights. Have a helper or your counter watch the other sailplanes in the air. Sometimes your sailplane will wiggle so quickly or gently that you may miss it if you are not paying close attention. If you find a productive thermal, don't leave it because your helper tells you that someone else has found a different one.

Know Your Sailplane: Learn what your sailplane will and won't do and fly within this envelope. This will allow you to ride thermals downwind while knowing when you have to head back to make your landing safely.

Learn From The Wind: Keep track of which way the wind is blowing. If the wind suddenly shifts, there is some thermal activity close to you. The air is probably being either sucked up into a thermal or falling out of some sink. In either case it is often a good idea to fly in the direction the wind is blowing if your sailplane is in the general area. This will take you towards a thermal if there is one or away from the sink, both of which are desirable.

BALLASTING

In strong wind conditions, you may want to add ballast (weight) to the sailplane to increase its wing loading which increases its normal flying speed. Increasing the weight of your sailplane does not change its "glide ratio" but it does make it fly faster. Because of the faster sink rate, you need to be very cautious when ballasting for a thermal contest. In duration type contests only use ballast on very windy days that also have a lot of thermal activity.

Add the weight as near as possible to the C.G. of the plane. Adding 6 – 8oz (170 – 225g) will make a noticeable difference in the sailplane's flying speed and more can be added later, if needed. Make sure to recheck the C.G. of the plane after adding the ballast – it should not change.

Have a ball! But always stay in control
and fly in a safe manner.

GOOD LUCK AND GREAT FLYING!

This model belongs to:

Name

Address

City, State, Zip

Phone Number

AMA Number

www.carlgoldbergproducts.com