

TIGER 60



Instructions

The new **TIGER 60** offers the latest in aerodynamic technology in a great-looking aircraft. With its light loadings, low landing speeds, and tricycle landing gear, the **TIGER 60** makes a deluxe low-wing trainer. Yet, those same features, along with its long tail moment and clean, symmetrical airfoil come through with super smooth aerobic performance. Loops, square loops, and Cuban eights groove perfectly, rolls are on-a-wire axial, and inverted flight couldn't be easier. Plus, all you really need for truly sparkling performance is a .60 to .65 two-cycle. Anything bigger would simply be excessive.

Before you start, please read through these instructions and review the plans to become familiar with the **TIGER 60** methods of assembly. Having said this, we hope you enjoy your new **TIGER 60** as much as we have. It has become one of our favorite aircraft to fly!

WARNING

A radio-controlled model is not a toy. It is capable of causing serious bodily injury and property damage. It is the buyer's responsibility to build this kit correctly and to properly install the motor, radio, and all other equipment. The first test flights should be made only with the assistance of an experienced R/C flyer. The model must always be operated and flown in accordance with the safety standards of the Academy of Model Aeronautics.

Per the Federal Communications Commission, you are required to use only those radio frequencies specified "for Model Aircraft."

CARL GOLDBERG PRODUCTS, Ltd.

P.O. Box 818 4462 Oakwood Rd. Oakwood, GA 30566 Ph # 678-450-0085

INTRODUCTION

USING THIS INSTRUCTION MANUAL

Like a full-size airplane, the TIGER 60 is built from basic structures (stabilizer, fin, wing, etc.), which are then assembled into the complete airplane.

Special procedures or comments will usually be explained before a step, so you will be prepared. If a step begins with a statement like "Note," "Warning," or "Important," it is a good idea to read through the step before doing it.

A check-off box appears at the beginning of each step. Check these boxes as you build, so you can tell at a glance what steps you have completed. Some steps require you to repeat them, as in the case of the left and right wing panel.

Example:

- | | | |
|-----|--------------------------|---|
| 11. | <input type="checkbox"/> | Position the wing portion of your plan over your building board. |
| | <input type="checkbox"/> | Lay waxed paper over the plan. |
| | <input type="checkbox"/> | <input type="checkbox"/> Lay two strips of masking tape, sticky side up, over plan, as shown. |

Some of the instructions deal with general procedures. Boxes are not needed for these sections.

HOW TO READ THE PLAN

The plan shows the Fuselage (Body), the Wing, and the Tail Parts. Everything on the plan is drawn to full-size and shape and shows how the finished parts fit together.

The plan is drawn to show the model completely assembled, but as a result, the areas inside or underneath are covered up, making it hard to understand how these parts fit together. Therefore, for clarity, some parts are drawn with hidden lines, others with breakaway views, and some are entirely removed from the structure and shown separately.

For example, on the fuselage, the left side of the completed model has been removed to show the details inside. Sometimes a surface is broken away to reveal the detail behind or underneath. Dashed lines indicate details that are hidden behind or under another part of the surface.

The model is made from four varieties of wood: balsa, bass, birch, and various plywoods. Each kind of wood has its own characteristic *end grain pattern* (as viewed from the end) which has been drawn on the plan. You can easily use these end grain patterns to identify what kind of wood is shown for a part, if you are in doubt.

IDENTIFYING PARTS

Parts for the wing are bundled together; likewise, parts for the tail assembly are also grouped. Die-cut plywood and balsa sheets of common sizes are bundled together, so they are less likely to be damaged during shipping and handling.

The various screws, hinges, and fittings are packaged in plastic bags.

HOW TO USE THE PLAN

The plan is used in several ways. The wings, stabilizer, and fin are assembled directly over the plan. Each wood part is matched over its corresponding location printed on the plan and pinned in place. To prevent ruining your plan from gluing your wings, etc. to it, cover the area you are working on with waxed paper or plastic kitchen wrap.

Because the fuselage plugs together and is self-aligning, it is not built directly over the plan. As you assemble the fuselage, you will find the plan helpful in identifying parts and how things fit together.

The plan also shows the installation of a typical radio, battery and all remaining equipment and hardware needed to complete the model. By referring to the examples shown, you should be able to install your own radio, etc., even if it is not the same as what is shown on the plan.

PREPARING FOR ASSEMBLY

Set a flat, warp-free pinning board on your work bench. Any material that accepts pins, such as insulation board, soft plywood, or dry-wall (sheet rock) will work. **Important: any warps or bands in the pinning board will result in wings or tail surfaces that are also warped or bent, making your model more difficult to fly.** Make sure that the pinning board is flat by laying a straight edge across it. You may be able to correct a warped board by shimming its low areas.

Position the area of the plan (such as the stabilizer) on which you are going to build over the pinning board and tape it in place so the plan lays flat and wrinkle free.

Place a sheet of waxed paper or plastic kitchen wrap over the work area to prevent glue from sticking to your plan and ruining it.

CONSTRUCTION TIPS

If you have never assembled a built-up model before, the following tips will prove helpful.

IMPORTANT: ALWAYS READ A FEW STEPS AHEAD. This will alert you to coming instructions and will help you plan accordingly.

You may find it convenient to empty all of the small parts from the hardware bags into a common container, such as a margarine tub. This will help you find items quickly.

When drilling the 1/16" hinge holes in balsa, you may find it easier to twist the drill between your thumb and index finger. This procedure allows more control in positioning the drill on the center mark.

Punch out only the die-cut (D/C) parts you need as you proceed. This will help you keep track of parts, especially the small ones.

ITEMS NEEDED TO COMPLETE THIS KIT.

- 1 RADIO GUIDANCE SYSTEM (4 CHANNEL MINIMUM REQUIRED)
- 1 ENGINE (.45-.60 2-CYCLE, .65-.80 4-CYCLE)
- 1 10-12 OZ. FUEL TANK
- 1 18" FUEL LINE
- 3 2-1/2" DIAMETER WHEELS
- 3 ROLLS ULTRACOTE™ COVERING
- 1 CGM 2-3/4" DIAMETER SPINNER
- 1 2 OZ. BOTTLE SUPER JET GLUE
- 1 1/2 OZ. BOTTLE INSTANT JET GLUE.
- 1 EPOXY PLUS
- 1 TUBE TINTED CGM MODEL MAGIC
- 1 PIECE CGM 1/2" FOAM PADDING
- 6 5/32" WHEEL COLLARS

TOOLS AND SUPPLIES REQUIRED FOR ASSEMBLY.

- MISCELLANEOUS RUBBER BANDS (INCLUDING #64)
- ROLL OF WAXED PAPER
- SANDPAPER (ASSORTED GRITS, INCLUDING MEDIUM (150) AND FINE (220))
- SANDING BLOCK
- "T" PINS (at least 50)
- X-ACTO MODELLING KNIFE
- SINGLE EDGE RAZOR BLADE
- RAZOR SAW
- BUILDING BOARD (24" x70")
- ELECTRIC DRILL
- 5/16" DRILL BIT
- 1/4" DRILL BIT
- 1/8" DRILL BIT
- 1/16" DRILL BIT
- 3/32" DRILL BIT
- 5/32" DRILL BIT
- SMALL SCREWDRIVER
- COVERING IRON AND HEAT GUN
- MASKING TAPE
- PLIERS
- YARD STICK
- 6" RULER
- 30-60 DEGREE x 6" TRIANGLE
- PENCIL
- HAMMER

WOOD PARTS

Be careful when removing parts (such as fuselage sides) from the die-cut sheets. Long parts are fragile until glued into a structural unit. If necessary, use a razor knife or razor saw to assist in the removal of parts from the sheet. Sometimes a little trimming and sanding can improve parts, where desired. Save scrap until the model is completed, in case a part is missing or damaged. Also, scrap is used in some building steps.

ABOUT THE WOOD IN THE KIT

We strive to supply good quality materials in your kit. Wood parts are inspected with regard to the function they will serve. If an imperfection is spotted in a scrap corner of a die-cut sheet and doesn't affect actual parts, the sheet is considered acceptable. Also, internal stresses in wood are relieved as it is cut into parts. These relieved stresses may cause some parts to bow. Bows in wood parts (such as leading edges) readily straighten out as they are glued into a structural unit.

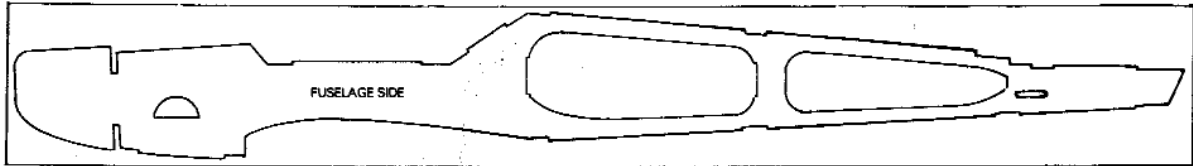

PT. #3900, D/C SHT. 6801 (2 REQ'D)

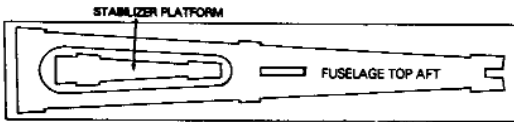

PT. #3901, D/C SHT. 6802 (1 REQ'D)

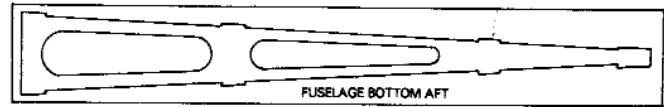

PT. #3902, D/C SHT. 6803 (1 REQ'D)

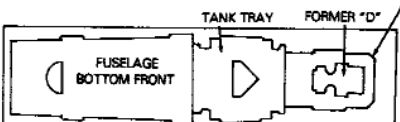

PT. #3908, D/C SHT. 6804 (1 REQ'D)

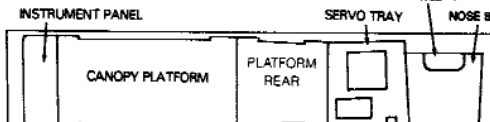

PT. #3909, D/C SHT. 6805 (1 REQ'D)

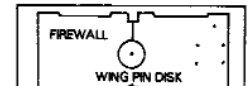

PT. #3911, D/C SHT. 6807 (1 REQ'D)

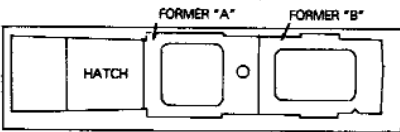

PT. #3910, D/C SHT. 6806 (1 REQ'D)

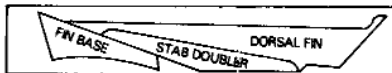

PT. #3903, D/C SHT. 6808 (2 REQ'D)

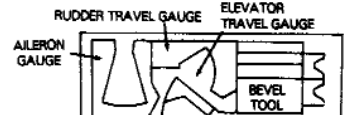

PT. #3913, D/C SHT. 6814 (1 REQ'D)



PT. #3904, D/C SHT. 6809 (4 REQ'D)



PT. #3905, D/C SHT. 6810 (2 REQ'D)

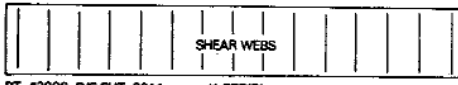

PT. #3906, D/C SHT. 6811 (1 REQ'D)



PT. #3907, D/C SHT. 6812 (4 REQ'D)

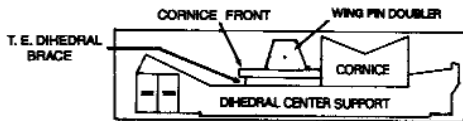

PT. #3912, D/C SHT. 6813 (1 REQ'D)

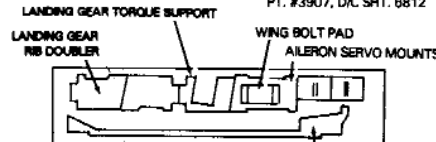

PT. #3914, D/C SHT. 6815 (2 REQ'D)

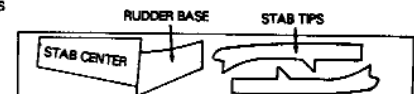

PT. #3917, D/C SHT. 6816 (2 REQ'D)

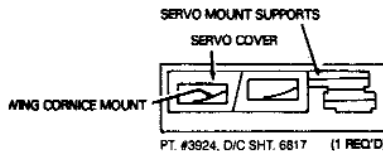

PT. #3924, D/C SHT. 6817 (1 REQ'D)

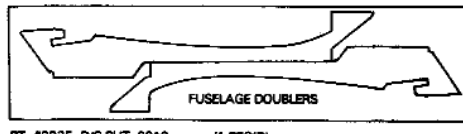

PT. #3925, D/C SHT. 6818 (1 REQ'D)



Pt# 3918 Sht 6801B (1 Req.)

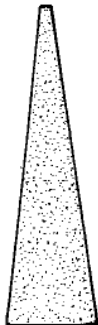

AILERON (2 REQ'D)



SHAPED L. E. (2 REQ'D)



NOTCHED T. E. (2 REQ'D)



3/8" SQ. x 33-1/2" BASSWOOD (4 REQ'D)



3/8 x 1/2 x 28" Balsa (5 REQ'D)



5/16 x 3-3/8" DOWEL (2 REQ'D)



3/8 x 1/8 x 24" Balsa (3 REQ'D)

5/64 x 1/4 x 21" Balsa (8 REQ'D)

HORIZONTAL STABILIZER CONSTRUCTION (14 Steps)

1. Collect all of the parts you will need to construct the HORIZONTAL STABILIZER.

THEY INCLUDE:

- (2) STAB CENTER (3/16" BALSA)
PT #3917, D/C SHT. 6816
- (2) STAB DOUBLER (3/16" BALSA)
PT #3903, D/C SHT. 6808
- (4) STAB TIPS (3/16" BALSA)
PT #3917, D/C SHT. 6816
- (1) BEVEL TOOL (.110" LITE-PLY)
PT. #3913, D/C SHT. 6814
- (1) RADIUS SANDER (.110" LITE-PLY)
PT. #3913, D/C SHT. 6814
- (1) HINGE STICK (3/8" x 1/2" x 28" BALSA)
PT. #4309
- (2) L.E. & BRACE (3/8" x 1/2" x 28" BALSA)
PT. #4309
- (2) TRUSS STICK (1/8" x 3/8" x 24" BALSA)
PT. #4310

- (6) JET HINGE PT. #1667
- (2) ELEVATOR (3/8" x 1-1/2" x 12" BALSA)
PT. #4312
- (1) ELEVATOR JOINER (5/16" x 3-3/8" DOWEL)
PT. #1749
- (1) CENTERLINE MARKER PT. #1425
- (1) PLAN PT. #2006

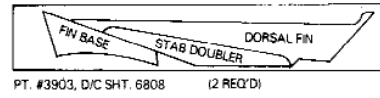

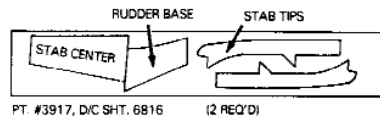

3/8 x 1/2 x 28" BALSA



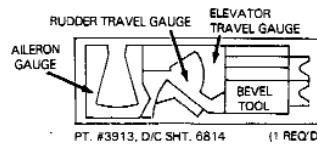

3/8 x 1/8 x 24" BALSA

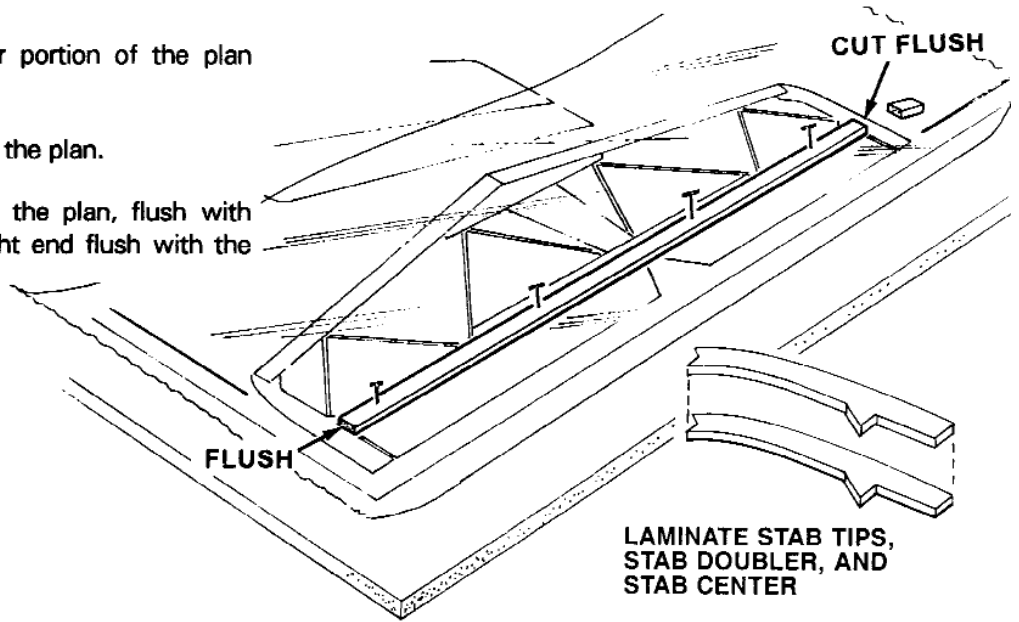

- 2. Lay the horizontal stabilizer portion of the plan over the building board.
- Place the waxed paper over the plan.
- Pin the HINGE STICK over the plan, flush with the left edge. Trim the right end flush with the plan.

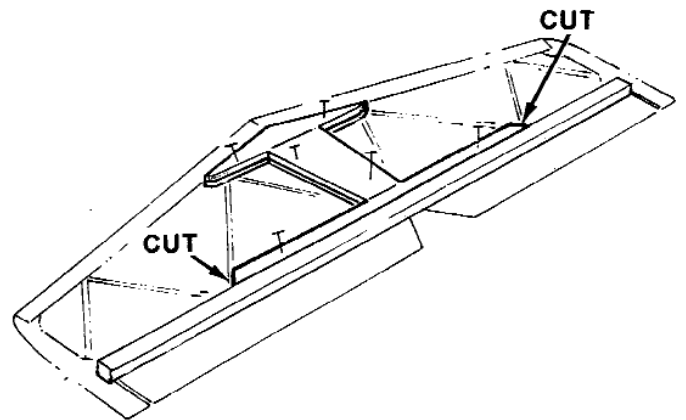

- 3. Trim a 3/8" x 1/2" balsa stick (BRACE) and glue to the hinge stick.
- Laminate the two 3/16" STAB CENTERS, STAB DOUBLERS, and STAB TIPS together.
- Glue and pin the STAB CENTER to the STAB DOUBLER.
- Glue the CENTER/DOUBLER ASSEMBLY to the brace.



4. Trim and glue the two LEADING EDGE parts to the stab joiner

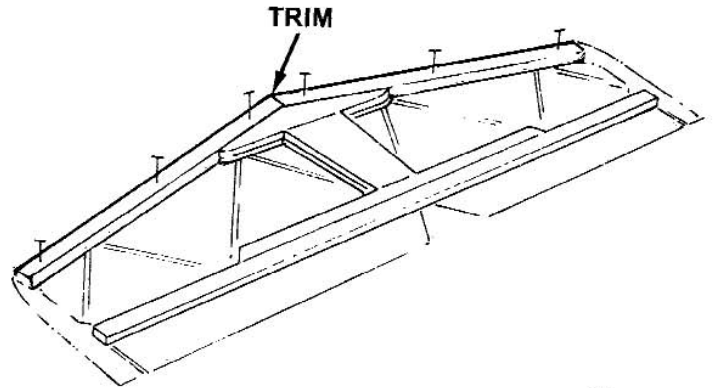

5. Glue the STAB TIPS to the leading edge and hinge stick.

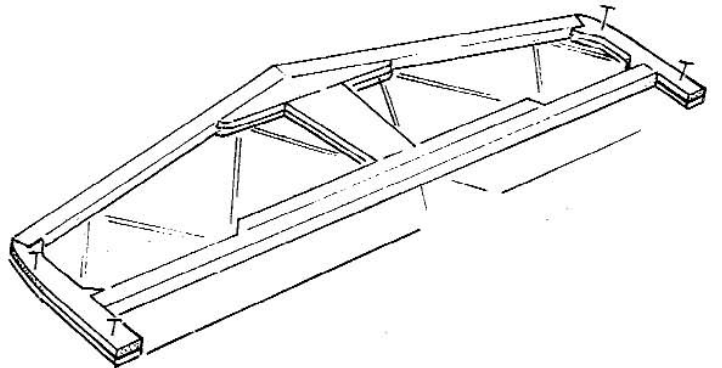

6. Trim to fit and glue the TRUSS STICKS into place.

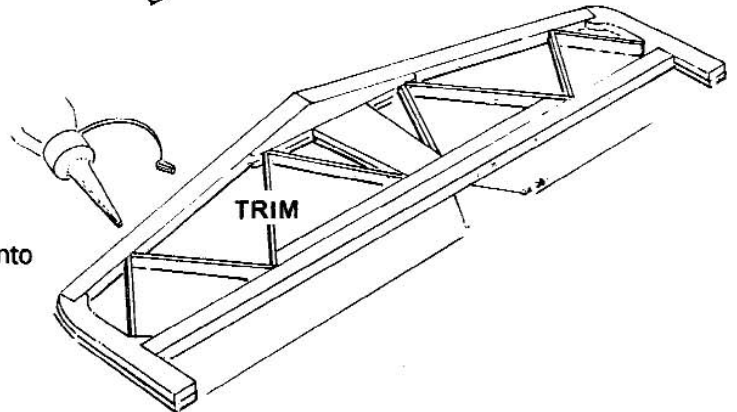

7. Using the plan as a guide, cut both elevator halves, as shown.

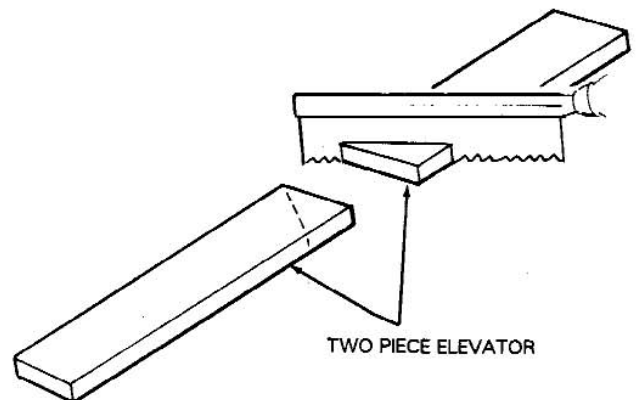

- With both elevators in position over the plan, mark, the center of the $5/16 \times 3-3/8$ " dowel. Carefully cut out the balsa and insert the dowel.

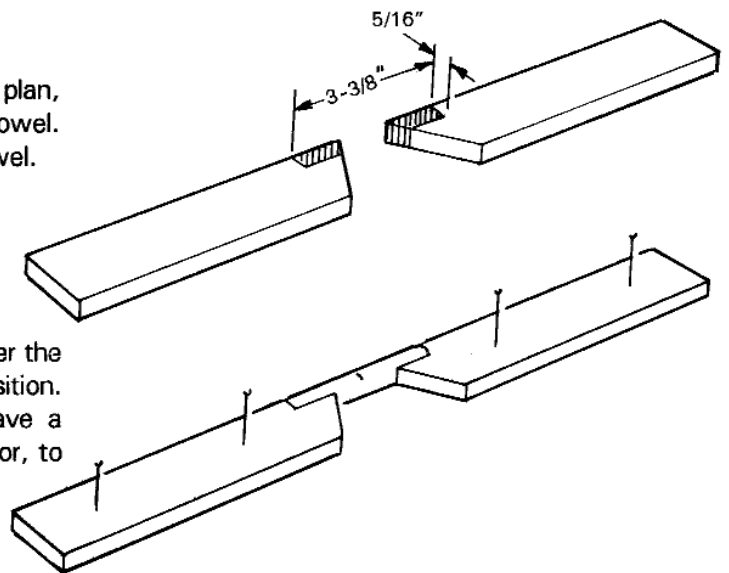

- 8. With the elevator assembly pinned down over the waxed paper and the plan, epoxy into position. Remember that the final assembly will have a $1/16$ " clearance at both ends of the elevator, to the stab.

- 9. Transfer the 6 hinge locations from the plan. Use the CENTERLINE MARKER to scribe a line down the center of the stab and elevator. See page 31 for JET HINGE instructions.

- 10. Use an X-acto knife to slot for JET HINGES. Test each JET HINGE location for the correct fit as you go.

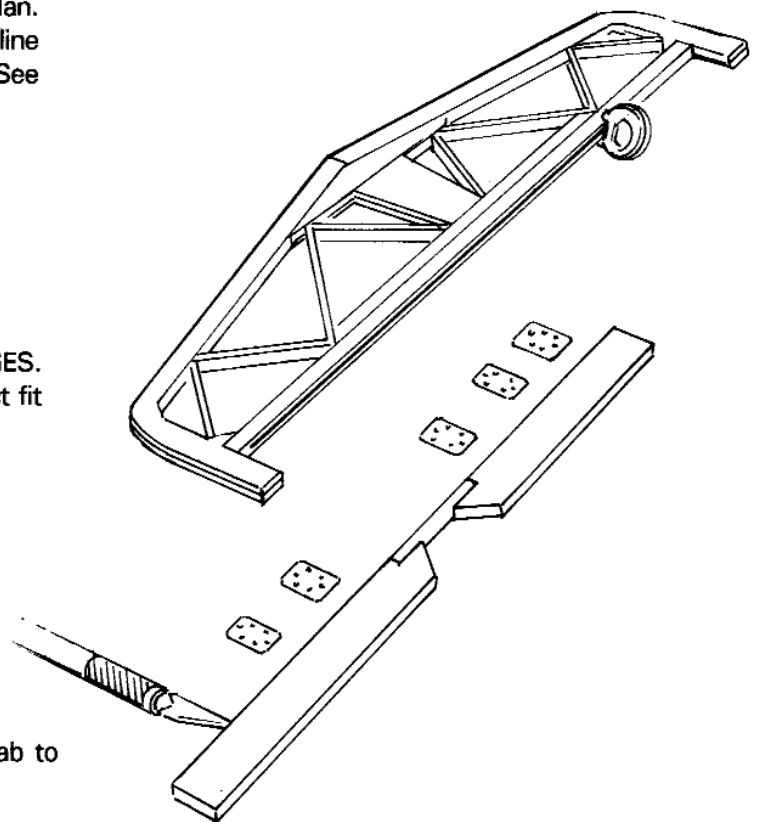

- 11. Temporarily install the hinges and fit the stab to the elevator.

12. Assemble the BEVEL TOOL and tack-glue a piece of **medium** sandpaper onto the small board.

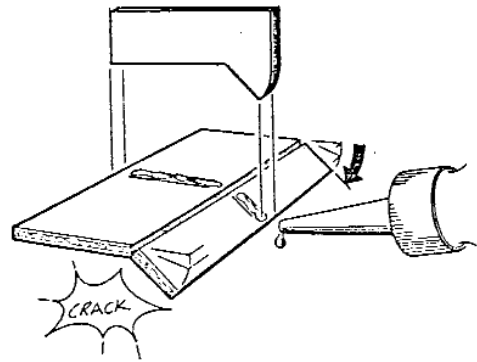

13. Use the bevel tool to sand the hinge side of the elevators. Sand both sides until a symmetrical bevel is formed along the entire length.

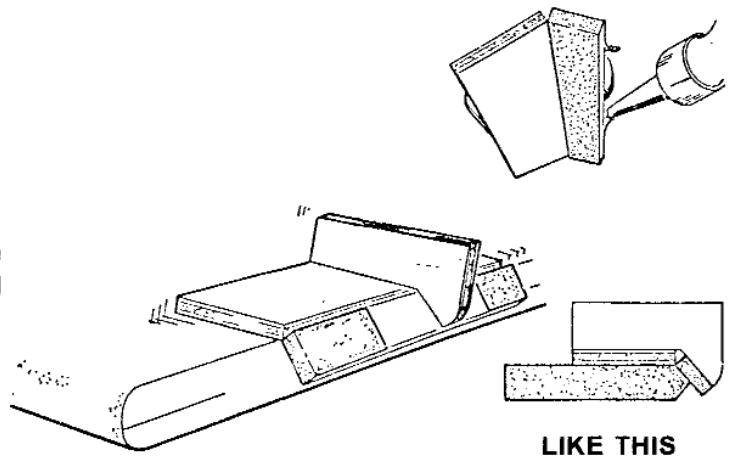

14. Build the RADIUS TOOL and insert a piece of **medium** sand paper. Use the tool to round the entire perimeter of the horizontal stabilizer. Remove the medium sandpaper and insert a piece of **fine** sandpaper and repeat. Use a sanding block with **fine** sandpaper to flat-sand both sides of the assembly.



THIS COMPLETES THE HORIZONTAL STAB AND ELEVATOR. YOU MAY PUT THEM ASIDE UNTIL YOU ARE READY FOR COVERING. NOW LET'S MOVE ON TO THE FIN AND RUDDER

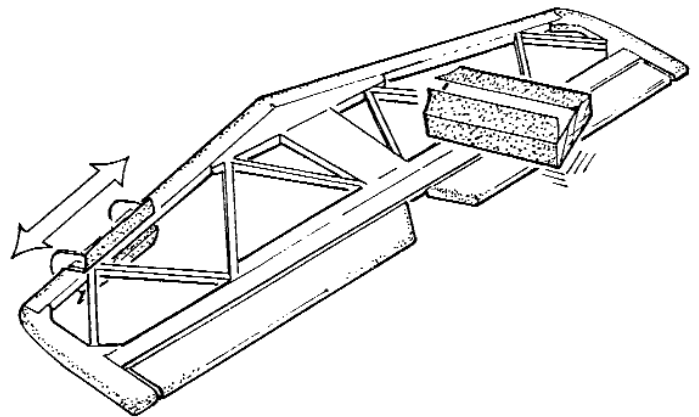

VERTICAL FIN & RUDDER CONSTRUCTION (8 Steps)

1. Collect all of the parts you will need to construct the VERTICAL FIN & RUDDER.

THEY INCLUDE:

- (2) DORSAL (3/16" Balsa) PT. #3903, D/C SHT. 6808
- (2) FIN BASE (3/16" Balsa) PT. #3903, D/C SHT. 6808
- (2) RUDDER BASE (3/16" Balsa) PT. #3917, D/C SHT. 6816
- (2) STICK (3/8" X 1/2" X 28" Balsa) PT. #4309
- (2) TRUSS STICK (1/8" X 3/8" X 24" Balsa) PT. #4310
- (3) JET HINGE PT. # 1667
- (1) PLAN PT. #2005

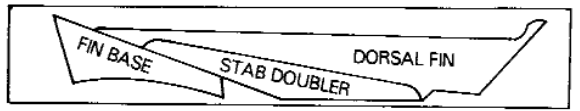
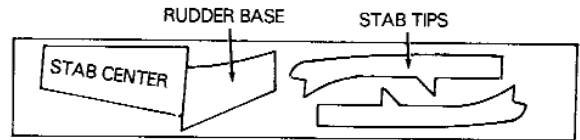

LAMINATE FIN BASE, DORSAL FIN, AND RUDDER BASE

- 2. Lay the vertical fin portion of the plan over the building board, and cover with waxed paper.
- Laminate the two 3/16" DORSAL, FIN BASE, and RUDDER BASE together.
- Pin and glue the DORSAL, L.E., FIN BASE and HINGE POST over the plan.

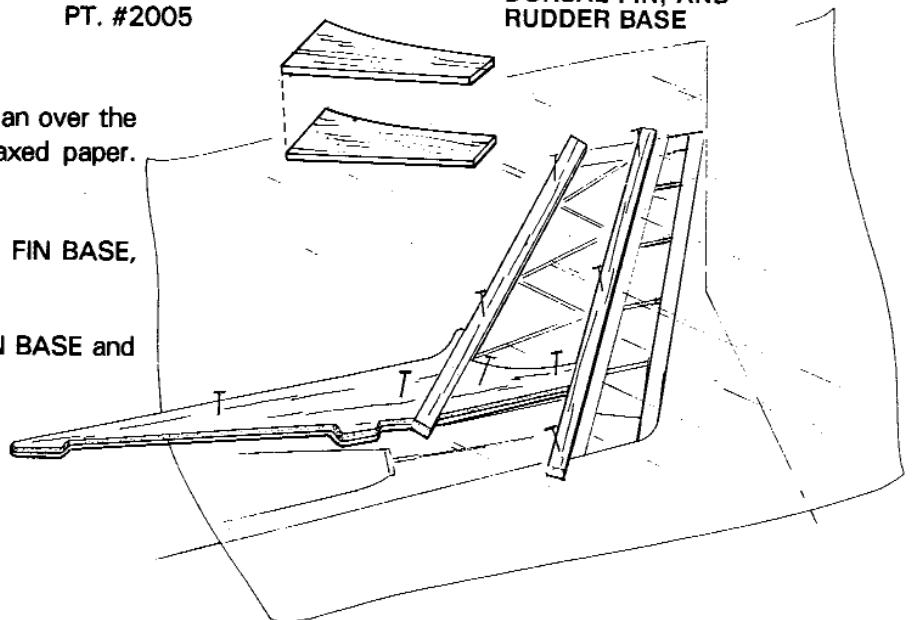

- 3. Trim to fit the 3/8" x 1/2" balsa FIN TOP and the 1/8" x 3/8" balsa TRUSS STICKS. Pin and glue in place.

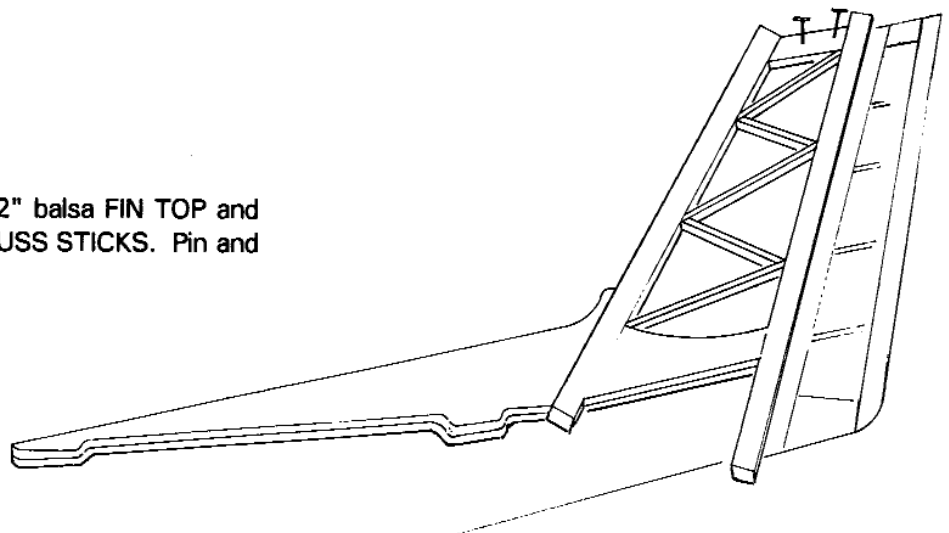

4. Trim, pin and glue the RUDDER parts together over the plan.

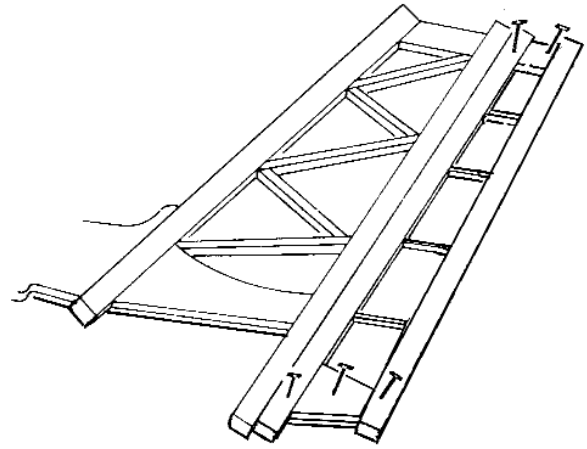

5. Use a razor saw to trim the ends. Use an X-acto knife to trim the DORSAL.

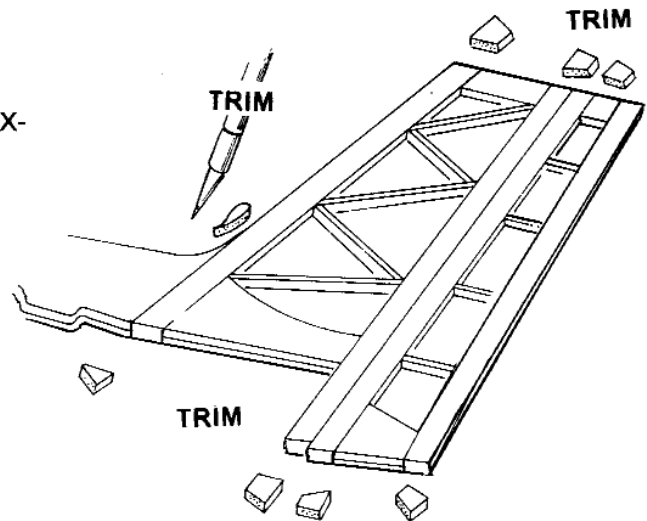

6. Transfer the hinge locations from the plans to the fin and rudder. Use the marking tool to scribe the centerline.

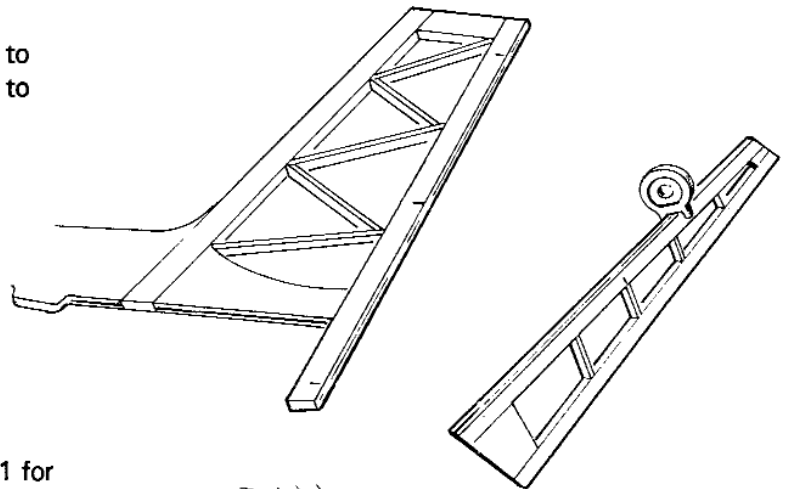

- Slot three JET HINGE locations. See page 31 for JET HINGE instructions. **Do not glue at this time.**

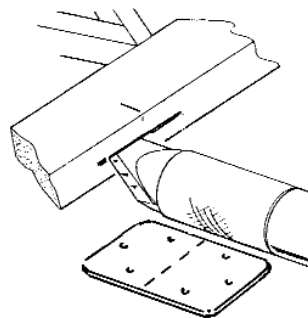

7. Use the bevel tool to bevel both sides of the hinge-side of the rudder.

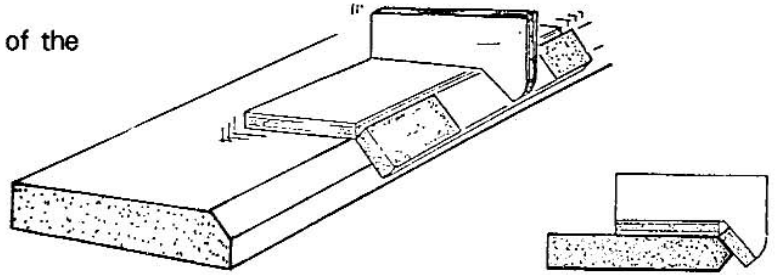

LIKE THIS

- Temporarily install the hinges and fit the rudder to the fin.

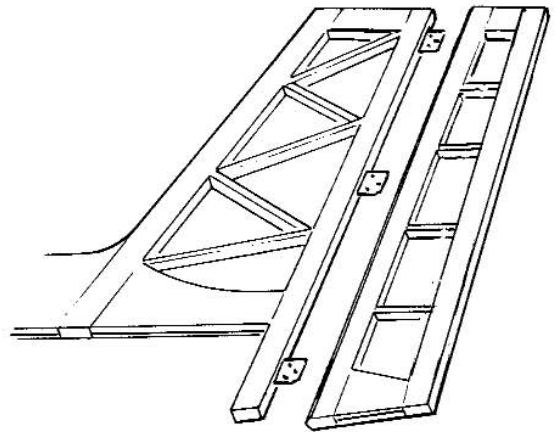

8. Use the rounding tool to round the perimeter segment "A" to "B". Flat-sand both sides of the fin/rudder.

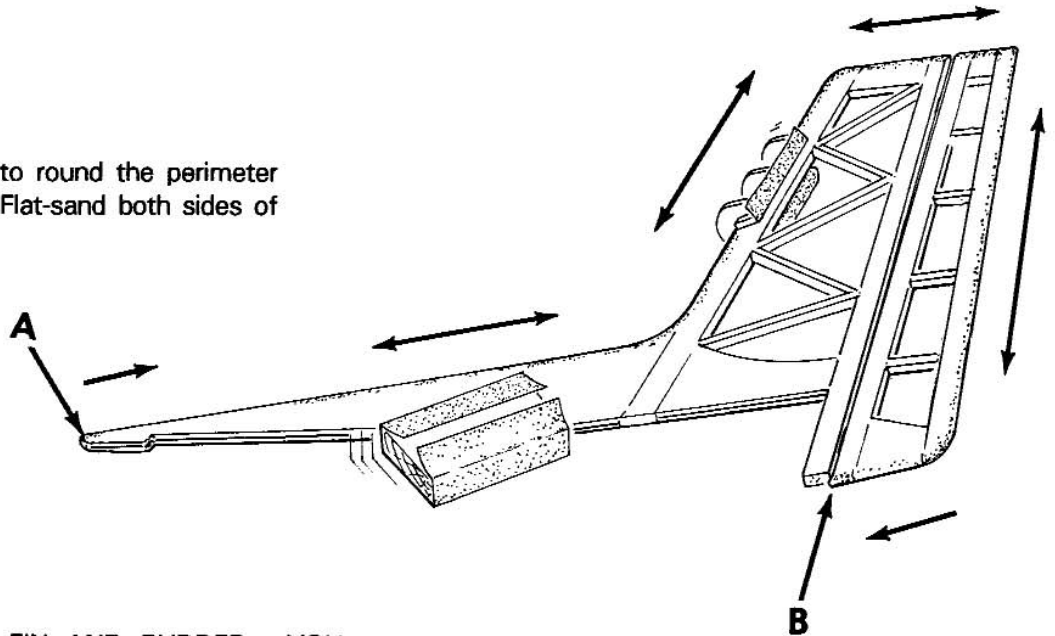

THIS COMPLETES THE FIN AND RUDDER. YOU WILL NOT NEED THESE PARTS UNTIL YOU ARE READY FOR THE COVERING, SO PUT THEM WITH THE HORIZONTAL STAB UNTIL THEN.

WING CONSTRUCTION (33 Steps)

1. Collect the parts needed to construct the WING.

THEY INCLUDE:

- (4) WING RIB SHEET (BALSA) PT. #3904, D/C SHT. 6809
- (2) WING RIB SHEET (BALSA) PT. #3905, D/C SHT. 6810
- (1) SHEAR WEBS (BALSA) PT. #3906, D/C SHT. 6811
- (4) CENTER SHEETING (BALSA) PT. #3907, D/C SHT. 6812
- (2) RIB DOUBLER (LITE PLY) PT. #3914, D/C SHT. 6815
- (1) T.E. DIHEDRAL BRACE (LITE PLY) PT. #3912, D/C SHT. 6813
- (1) WING DOWEL SUPPORT (LITE PLY) PT. #3912, D/C SHT. 6813
- (1) DIHEDRAL CENTER SUPPORT (LITE PLY) PT. #3912, D/C SHT. 6813
- (2) WING TIP T.E. SUPPORT (LITE PLY) PT. #3914, D/C SHT. 6814
- (1) WING PIN (5/16" X 3-3/8" BIRCH DOWEL) PT. #1749
- (2) SHAPED L.E. (SHAPED BALSA) PT. #3705
- (4) SPAR (3/8" SQ. x 33-1/2" BASSWOOD) PT. #3700
- (2) NOTCHED T.E. (SHAPED BALSA) PT. #4305
- (2) INBOARD T.E. (6" SHAPED BALSA) PT. #4879
- (2) AILERON (26-3/16" SHAPED BALSA) PT. #4308
- (2) OUTBOARD T.E. (1" SHAPED BALSA) PT. #4873

- (2) DIHEDRAL BRACE (1/8 x 1-1/2 x 3-1/2" BIRCH PLY) PT. #3586
- (4) L.E. SHEETING (5/64 x 2-7/8 x 34" BALSA) PT. #3915
- (4) T.E. SHEETING (5/64 x 1-1/4 x 34" BALSA) PT. #3916
- (2) WING TIP (1-3/4 TRI x 12-3/4" BALSA) PT. #3923
- (2) LANDING GEAR MOUNT (1/4 1 X 4-13/64" PLY) PT. #3921
- (2) TORQUE SUPPORT (1/4 x 1 x 15/16" PLY) PT. #3922
- (8) CAPSTRIPS (5/64" x 1/4" x 21" BALSA) PT. #4311
- (8) JET HINGE PT. #1667
- (1) NYLON FABRIC PT. #3709



SHAPED L. E. (2 REQ'D) NOTCHED T. E. (2 REQ'D) 3/8" SQ. x 33-1/2" BASSWOOD (4 REQ'D)

WING PIN

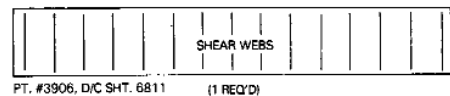
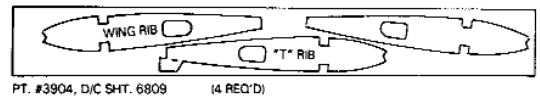
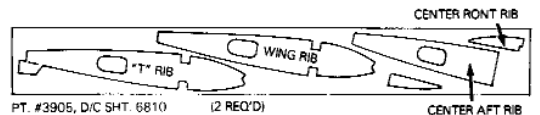
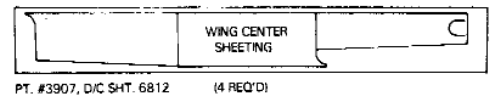
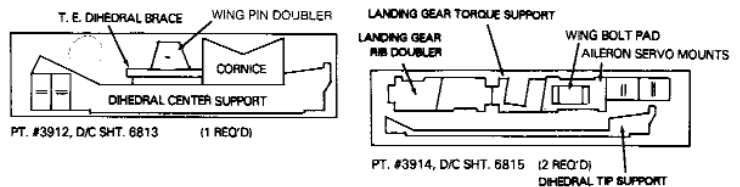

AILERON (2 REQ'D)

5/64 x 1/4 x 16" BALSA (8 REQ'D)

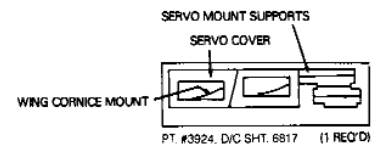

2. Lay the entire wing plan over the building board and completely cover with a sheet of waxed paper.

3. Place the NOTCHED TRAILING EDGE over the plan. Align the notches to the plan and cut off along the wing centerline. **Make sure that you align and cut the correct end.**

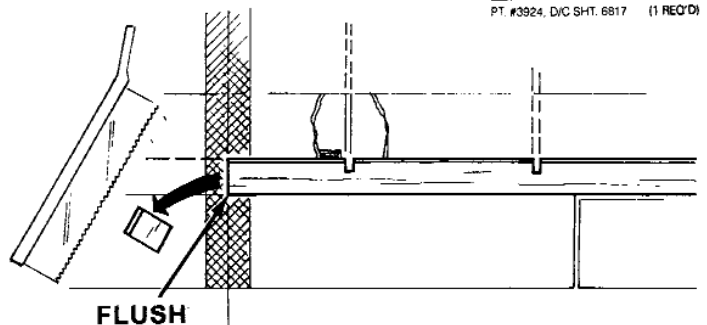

4. Wrap a piece of fine sandpaper around the 5/16" WING PIN and use as a sanding tool to sand the wing pin clearance into the end of the shaped LEADING EDGE.

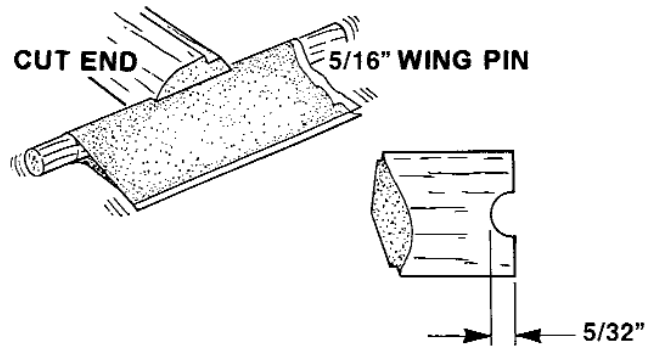

5. Scissors-pin a basswood SPAR over the plan. Make sure that the end is on the wing centerline.

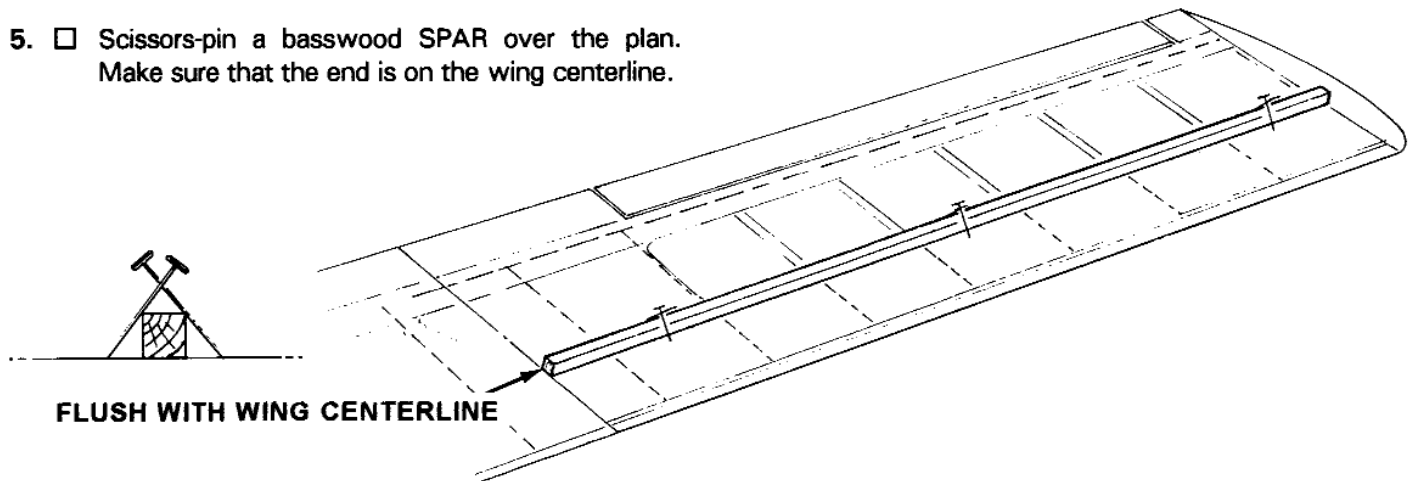

6. Pin the tabbed ribs, "T", at the "T" locations, over the plan. **DO NOT GLUE THEM TO THE SPAR AT THIS TIME.**
- Tape over tab break-off line on both sides of the tabbed ribs.

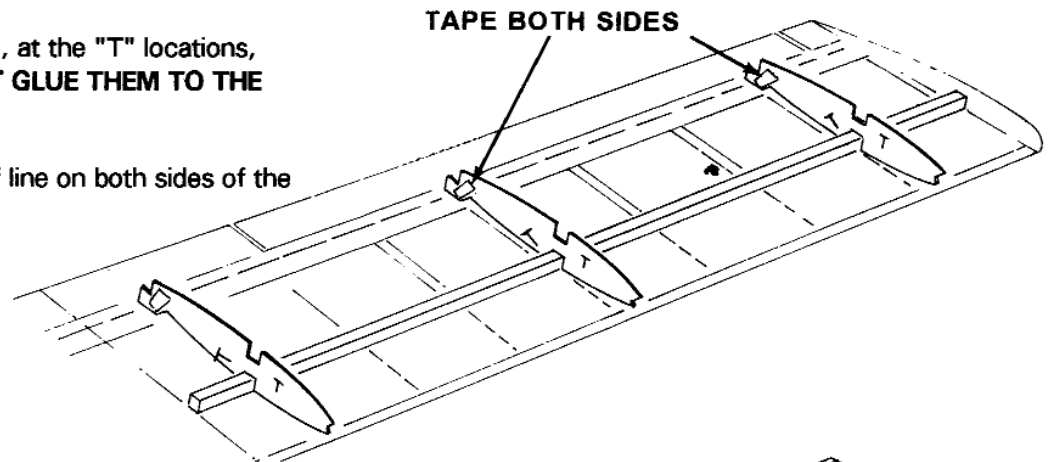

7. Install the notched T.E. onto the tabbed RIBS. Make sure that the trimmed end is flush with the wing centerline.
- Install the remaining wing ribs into the notches and down over the spar. Make sure to align the ribs with the plan.

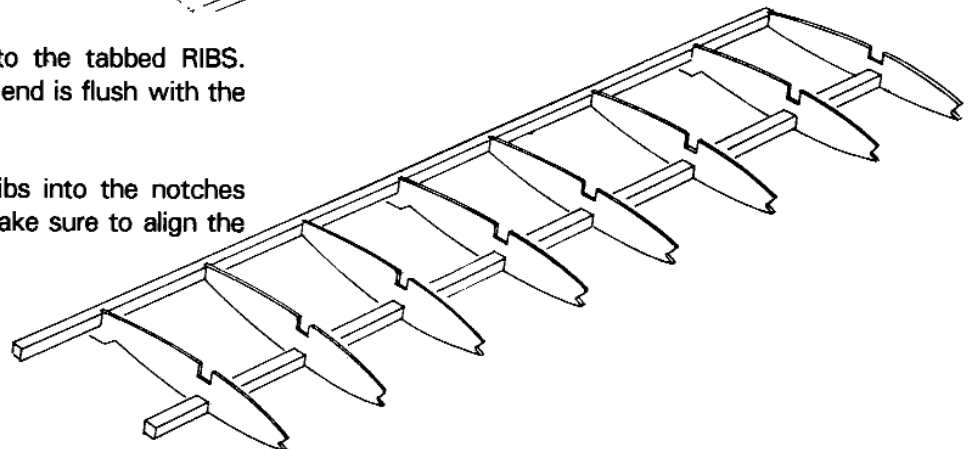

8. Using the SETBACK GAUGE as shown, install the top SPAR into the notches in each rib.
- With the wing-pin clearance at the wing centerline, pin the L.E. into the alignment "V" on each rib.

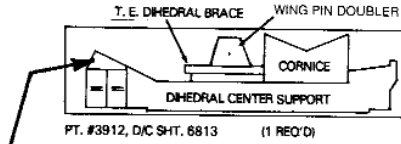

SET-BACK GAUGE

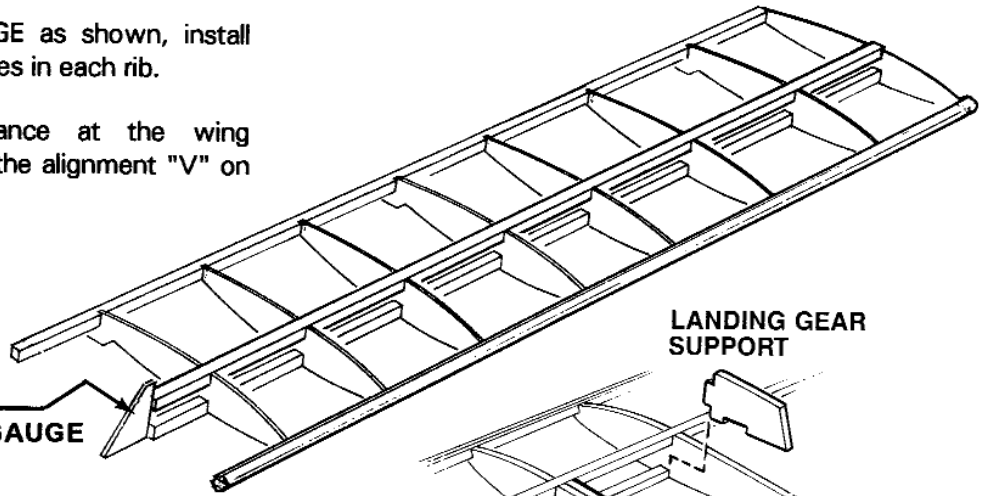

LANDING GEAR SUPPORT

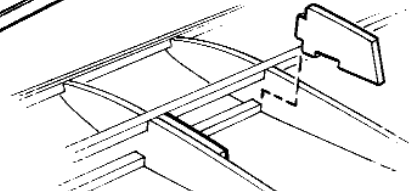

LANDING GEAR TORQUE SUPPORT

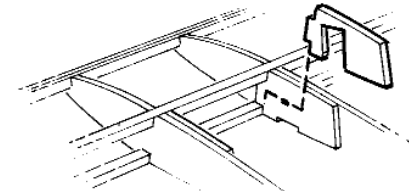

9. Epoxy RIB DOUBLERS in place. Be sure the rib doublers fit the rib outline. Remove excess epoxy.

10. Epoxy TORQUE SUPPORT in place.

11. Epoxy SERVO MOUNT SUPPORT and SERVO MOUNT to wing, as shown. Be sure supports fit the rib outline.

SERVO MOUNT SUPPORT

SERVO MOUNT

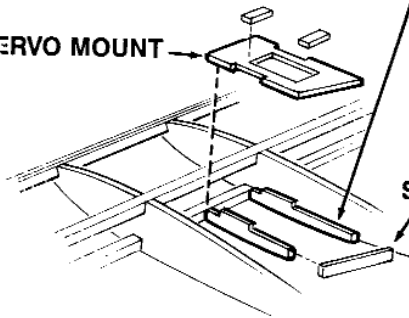

SCRAP

12. Glue and pin the L.E. SHEETING to the shoulder on the shaped L.E., rib camber, and the front half of the spar.

- Glue and pin the T.E. SHEETING to the notched T. E., flush with the back edge, and to the top of each camber of each rib.

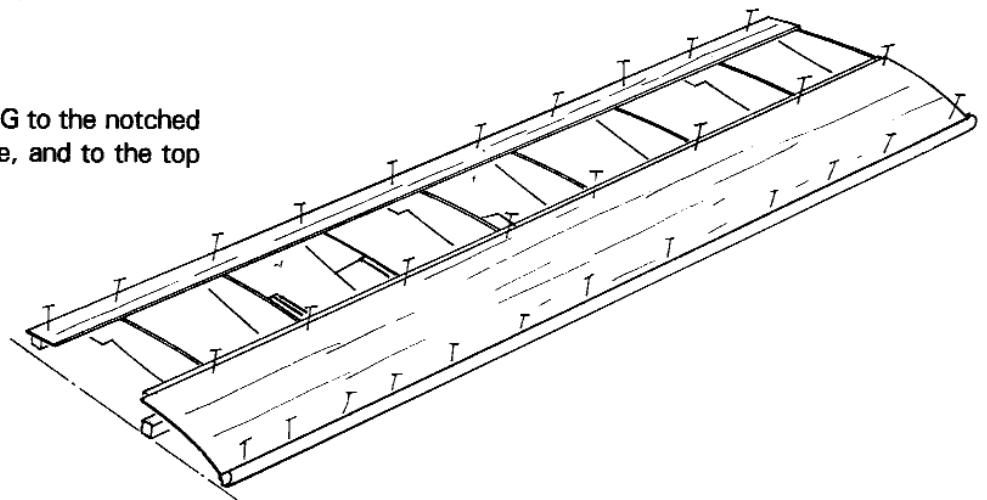

13. Glue the two edge pieces of the CENTER SHEETING to the ribs and WING SHEETING.

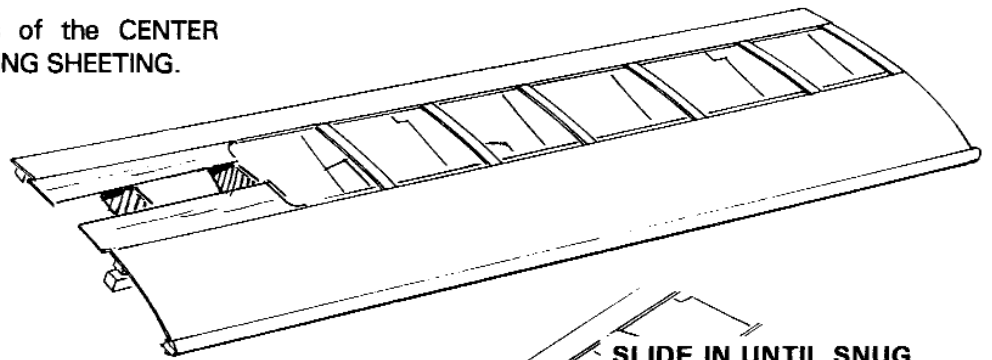

- For the **top** of the wing **only** remove die-cut u-shape from end of center section. This is to allow access for servo extensions. This is a good time to either install your extensions or a pull string to hook up your servos for when they are needed.

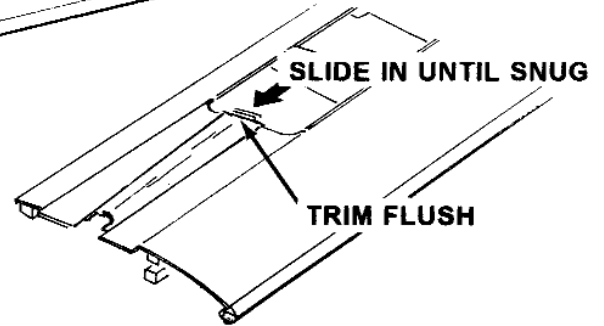

- Preglue and slide the wedge-shaped center piece in place until it fits snugly.

- Trim off the excess in line with the front and back center sheets.

14. Draw a cutline flush with the end of the L.E. to the end of the notched T.E.

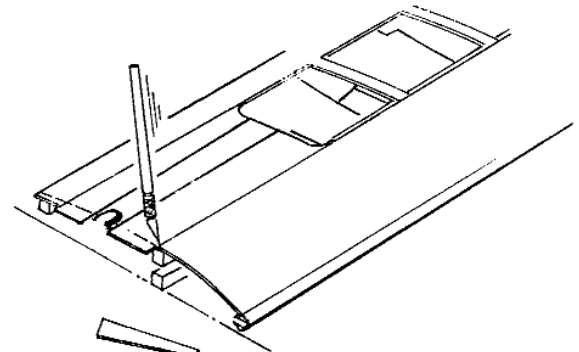

- Using an X-acto knife, cut along the line. Use a sanding block, if needed, to achieve a straight edge.

TRIM AS SHOWN

- Install the CAPSTRIPS.

- Remove the wing panel from the plan.

GO BACK TO STEP #3 AND REPEAT THE SEQUENCE FOR THE OTHER WING HALF. WHEN BOTH HALVES ARE COMPLETED, GO ON TO STEP #15.

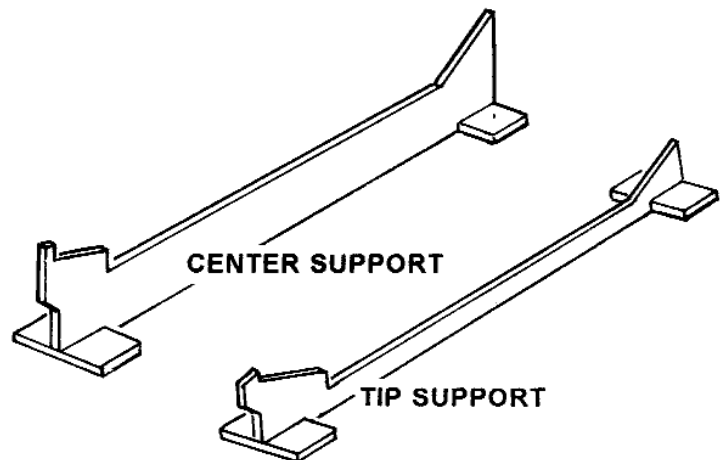

15. Assemble and glue the CENTER and TIP SUPPORTS.

- Position and pin the supports over the plan, as shown.

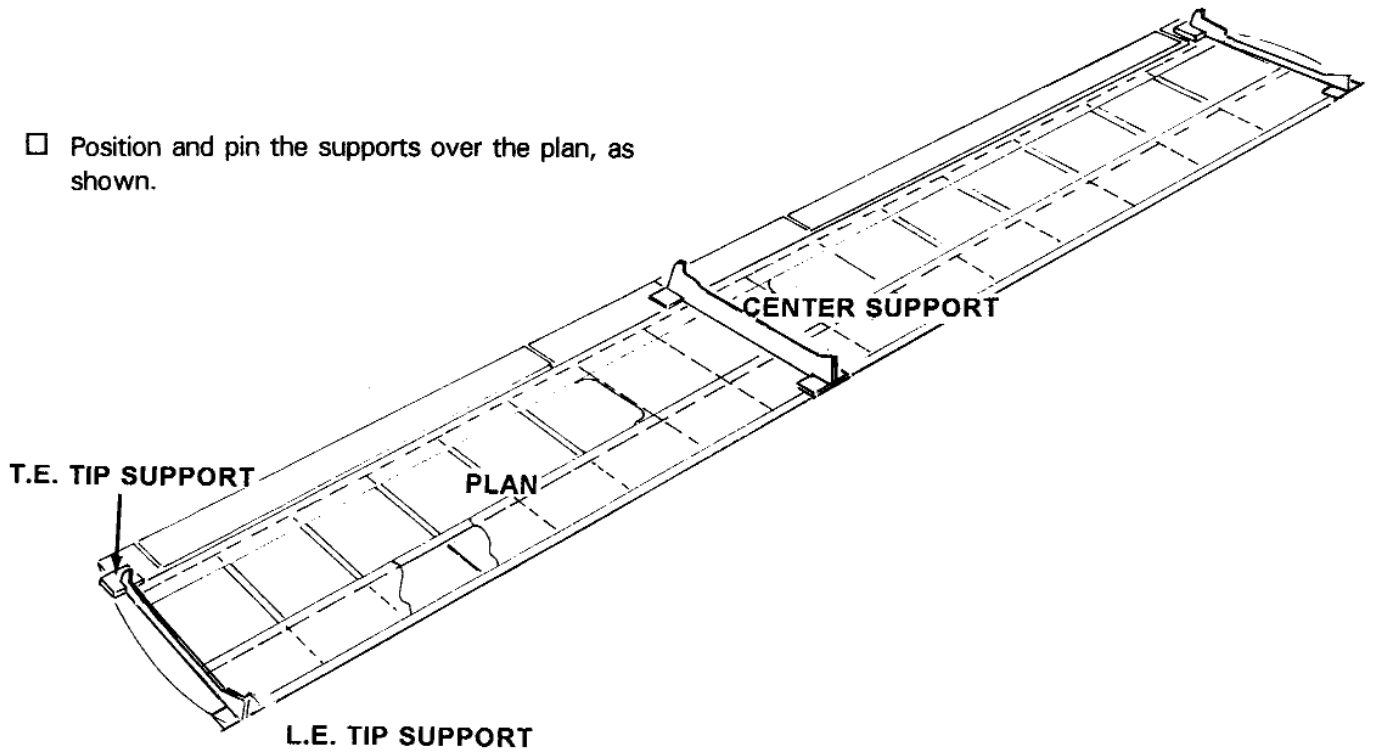

- 16. With the open framework (wing bottom) facing up, securely mount the wing panels onto the fixtures. Sand the centerline seam to produce accurate fit-up.

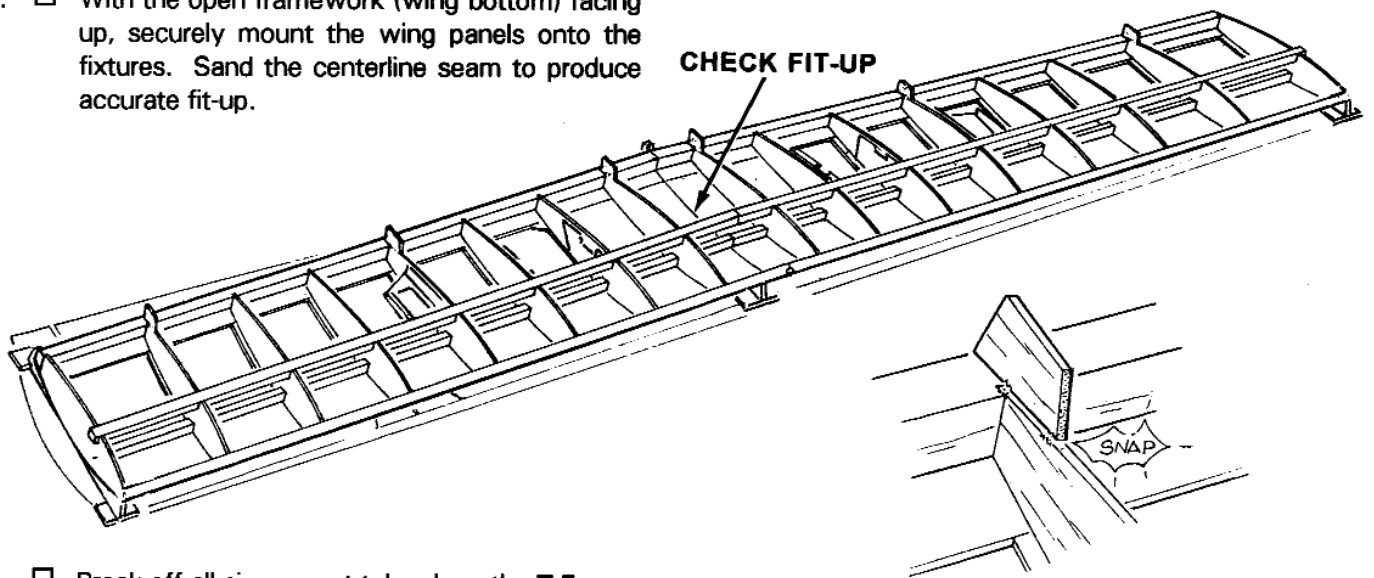

- 17. Break off all six support tabs along the T.E.

- 18. Flat sand the gluing surfaces of the DIHEDRAL BRACES and generously epoxy them to the spars.

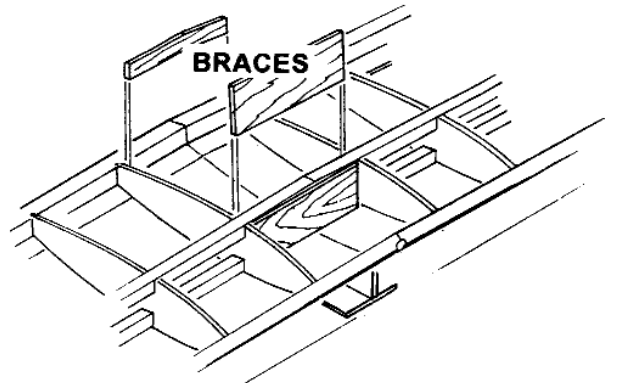

19. Break off the 5/64" balsa SHEAR WEBS from the die sheet and glue onto the spars.

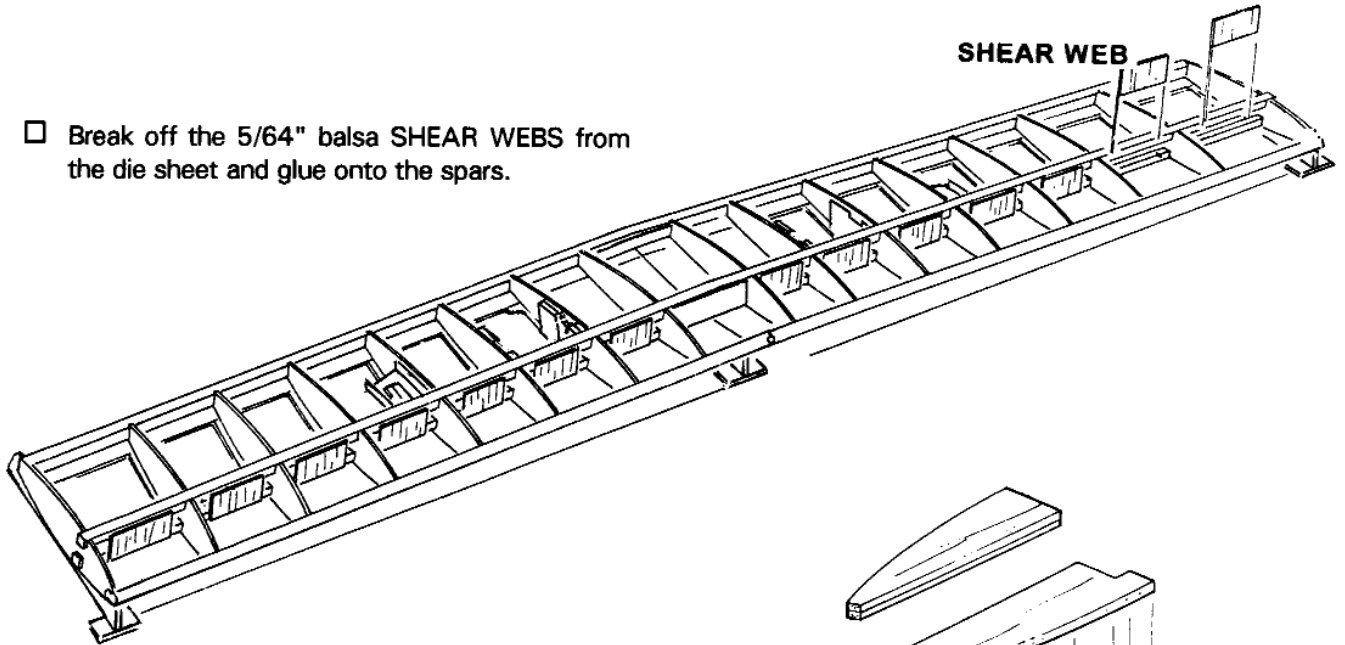

20. Laminate each pair of the CENTER-FRONT RIBS together.

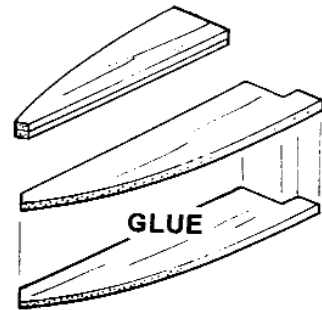

- Drill a 5/16" diameter hole at the center-mark on the lite ply WING PIN DOUBLER.

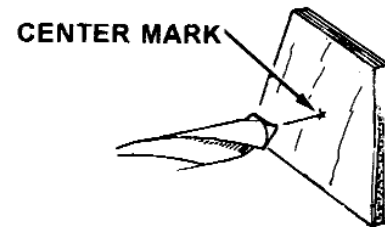

21. Install a center-front rib assembly.
- Glue the wing disc to the dihedral brace. Be sure that the 5/16" hole is aligned with the center rib.
- Slide the 5/16" WING PIN through the L.E. along the center rib and into the wing disc.
- Install the other center-front rib assembly.

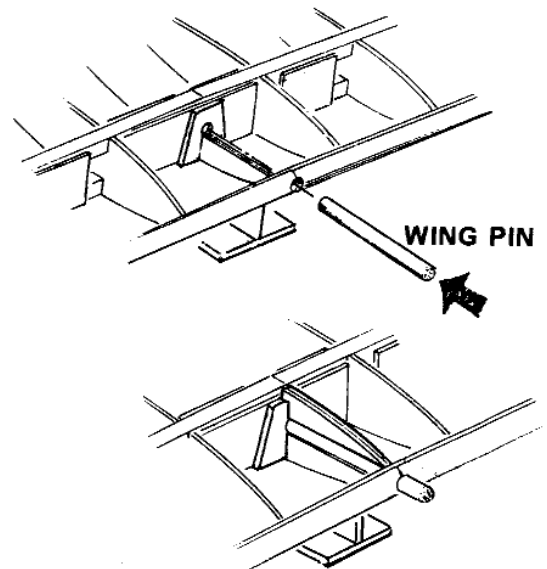

22. Laminate the CENTER-AFT RIB together.

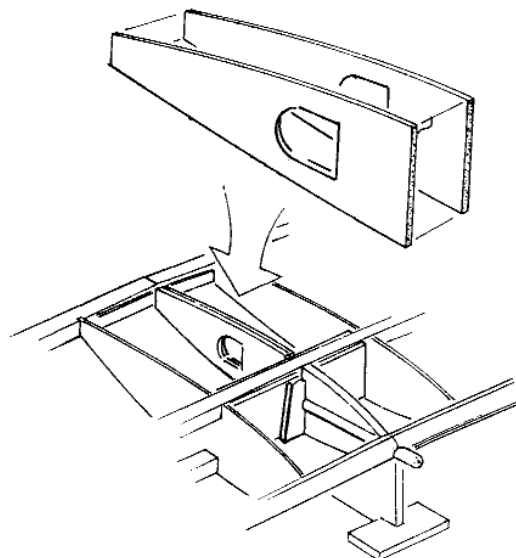

23. Install the L.E. and T.E. sheeting, fitting the center seam as required.

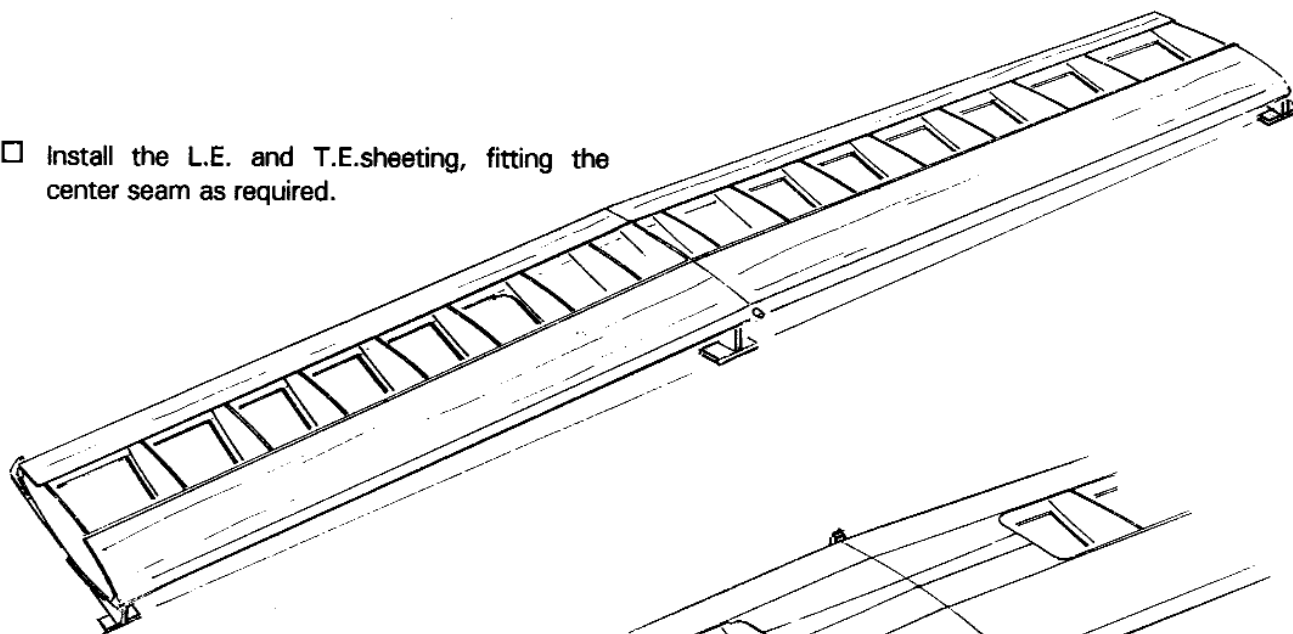

- Install the center sheeting, trimming to fit as you proceed.

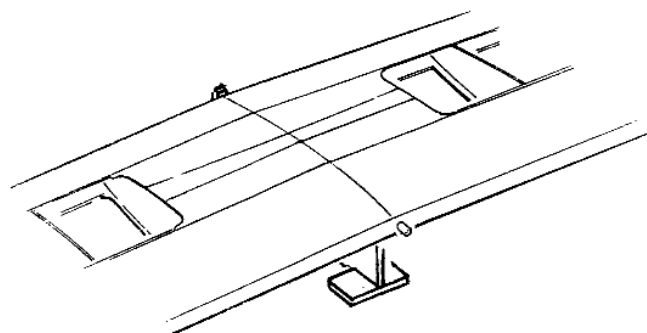

24. Epoxy in TORQUE SUPPORT.

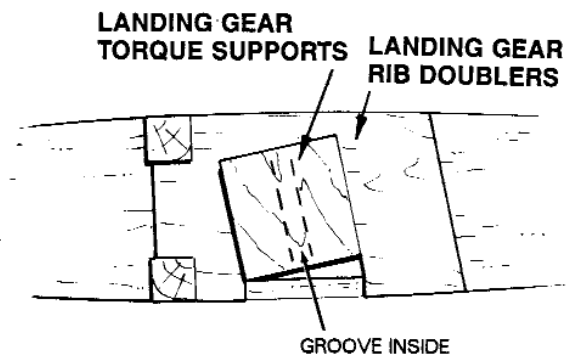

25. With the notch toward the center, and the groove facing out, generously glue the LANDING GEAR MOUNT.

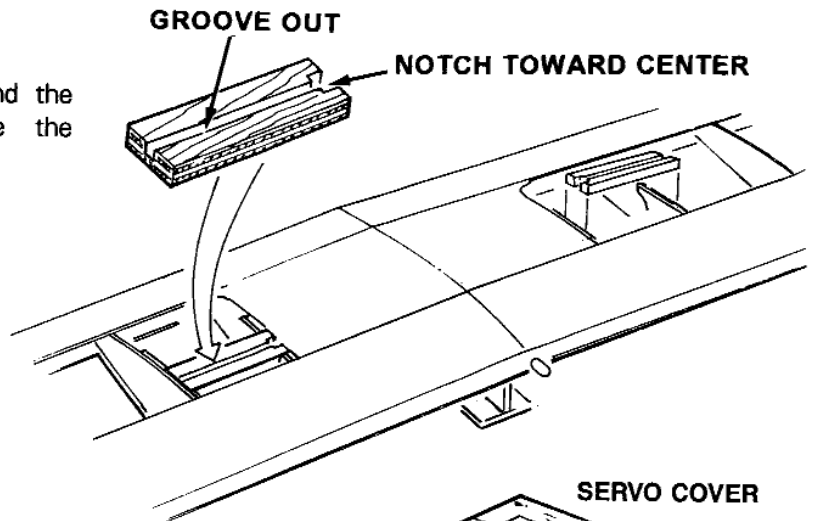

26. Glue in 5/16" balsa SERVO COVER with balsa CAPSTRIP.

NOTE: The servo can be installed or removed with the SERVO COVER installed. The Y-chord or extension must be installed before covering.

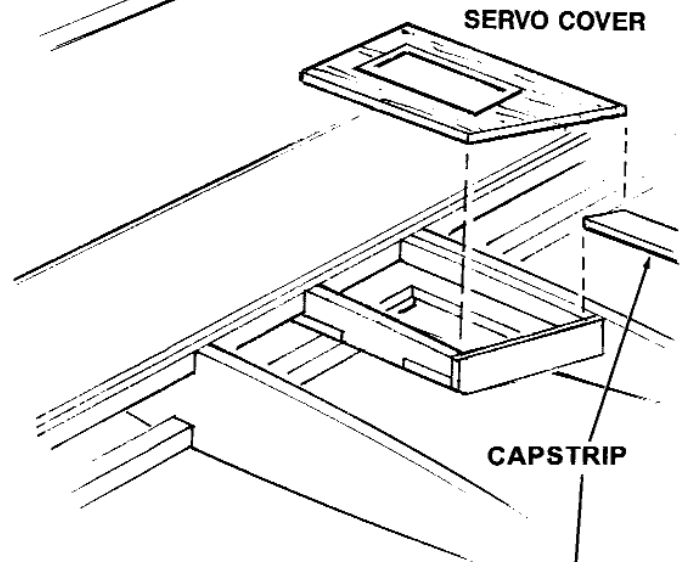

27. Install the CAPSTRIPS on the entire bottom of the wing.

- Using the sanding block with **fine** sandpaper, sand along the T.E. to make flat, as shown.

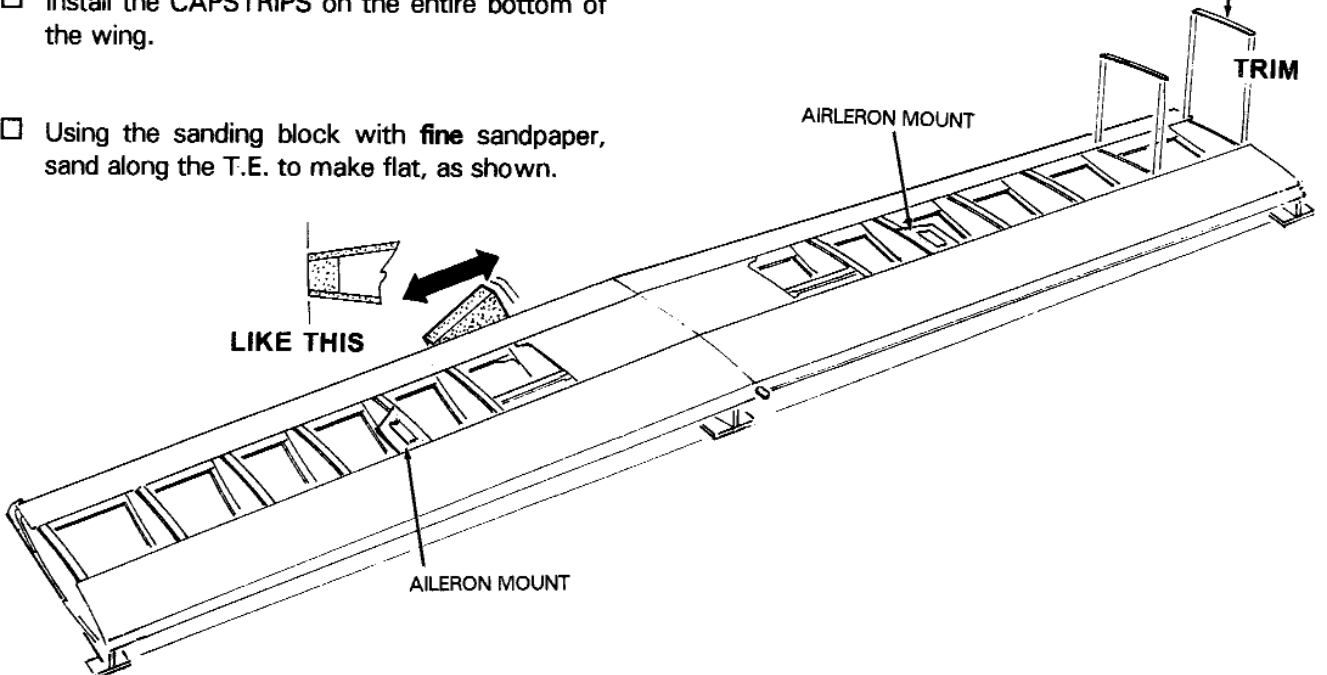

- 28. Remove the wing from the building board.
- Flat sand the end ribs, as shown.
- Mark a centerline on the TRI-STOCK WING TIP.
- Glue the tip to the end rib, locating the centerline on the mid-point of the L.E. and T.E.
- Glue the OUTBOARD T.E. to the tip and T.E.

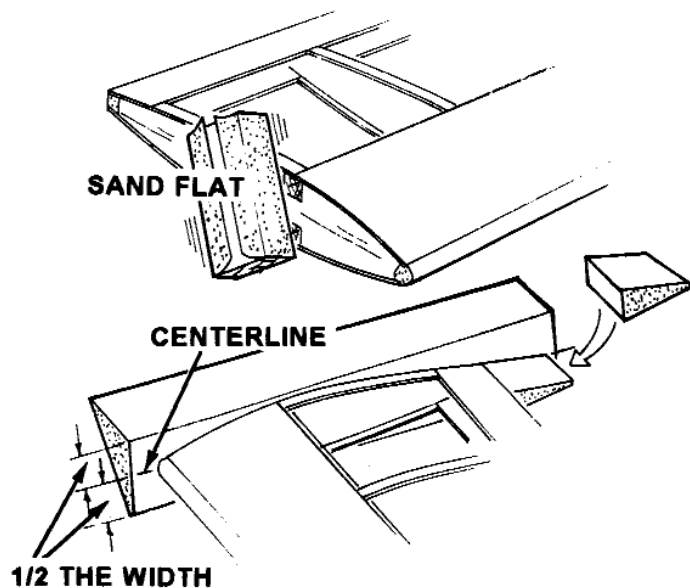

- 29. Rough carve the tips to shape. Sand to the final shape, using **medium**, and then **fine**, sandpaper.

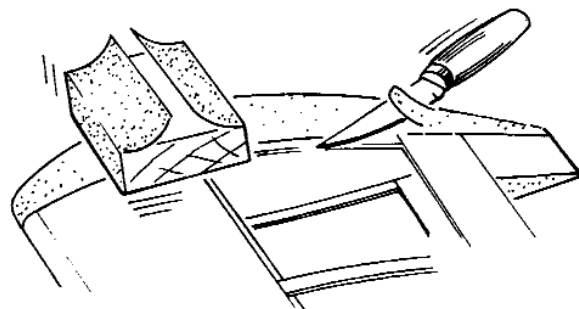

- 30. Glue the INBOARD T.E. in place, as shown. Be sure center section aligns with tip. Use aileron length *plus* 1/8" to gauge.

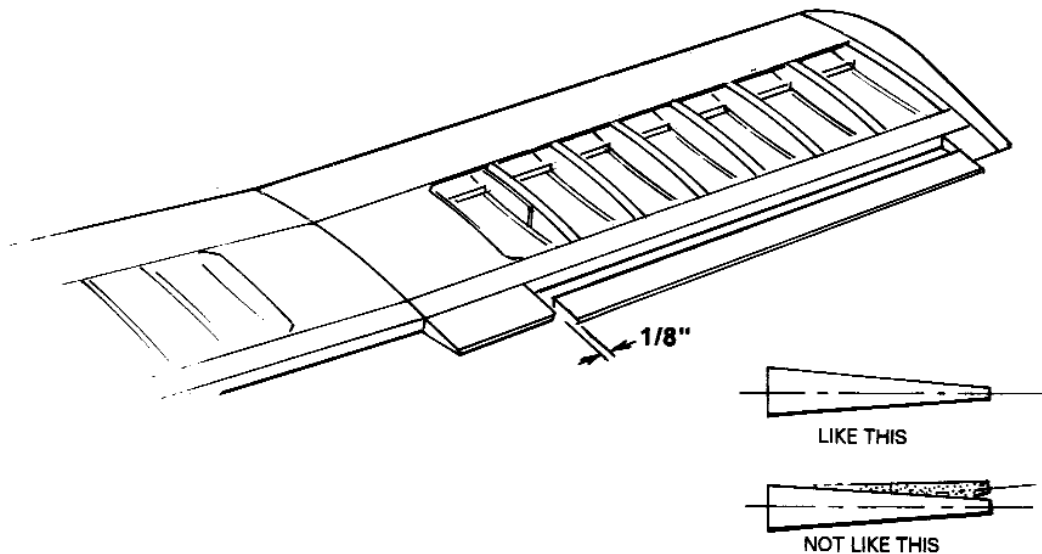

31. Check that the AILERON has at least 1/16" clearance on each end. Trim, if needed.

See page 31 for JET HINGE instructions.

Transfer the four locations for JET HINGES.

Slot the Jet Hinge locations, using your Exacto knife. **Do not glue at this time.**

Bevel both sides of your ailerons.

Test for proper fit.

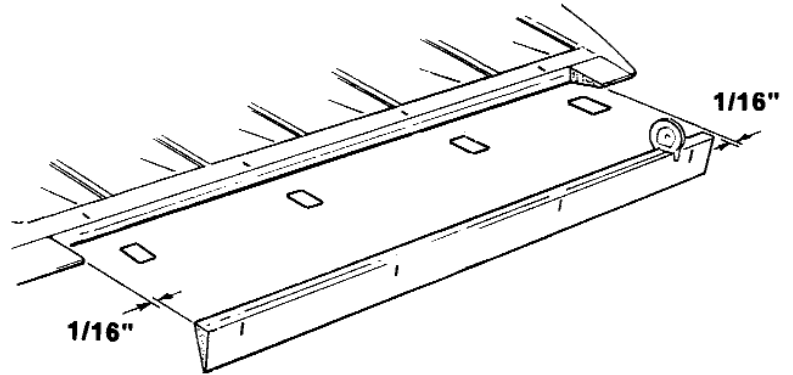

32. Finish sand the entire wing.

Wrap the center of the wing, using 2-1/2" NYLON FABRIC.

Use a small plastic bag over your finger to smooth INSTANT JET over the nylon tape.

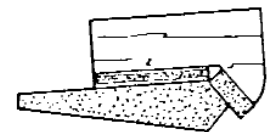
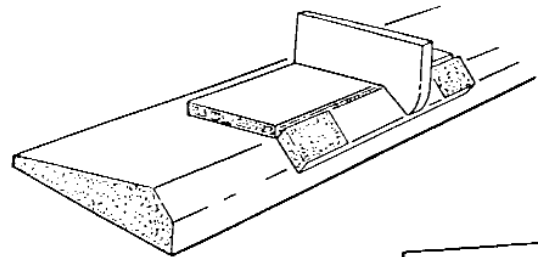

LIKE THIS

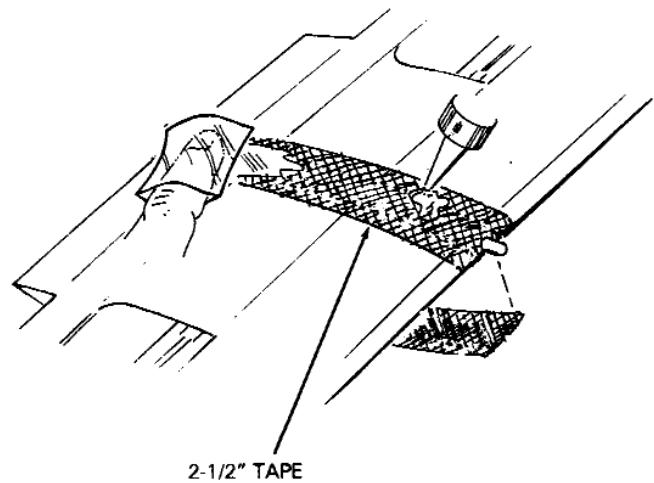

CONSTRUCTING THE FUSELAGE (25 Steps)

1. Collect all the parts that you will need to construct the FUSELAGE.

THEY INCLUDE:

- | | | |
|---|-----------------|--------------------------|
| (2) FUSELAGE SIDE | (.110 LITE PLY) | PT. #3900, D/C SHT. 6801 |
| (1) FUSE. TOP AFT, STAB PLATFORM | (LITE PLY) | PT. #3901, D/C SHT. 6802 |
| (1) FUSE. BOTTOM AFT, FUSE. DOUBLERS | (L-PLY) | PT. #3902, D/C SHT. 6803 |
| (1) FUSE. BOTTOM FRONT & FORMERS "C" & "D" | (LITE PLY) | PT. #3908, D/C SHT. 6804 |
| (1) CANOPY PLATFORM & INSTRUMENT PANEL | (LITE PLY) | PT. #3909, D/C SHT. 6805 |
| (1) FUSELAGE TOP FRONT, HATCH, & FORMER "A" & "B" | (LITE PLY) | PT. #3910, D/C SHT. 6806 |
| (1) FIREWALL & WING PIN DISK | (BIRCH PLY) | PT. #3911, D/C SHT. 6807 |
| (2) HATCH RAILS (3/8 x 1/2 X 6-1/4" SHAPED BASS) | | PT. #4313 |
| (2) WING MOUNTING BLOCK | (BIRCH PLY) | PT. #4896 |
| 1/4 x 3/4 x 1-13/16" | | |
| (2) ENGINE MOUNTS | | PT. #1466 |
| (1) NYLON STEERING BEARING | | PT. #1413 |
| (4) 4-40 BLIND MOUNTING NUTS | | PT. #1125 |
| (4) #4 FLAT WASHERS | | PT. #1139 |
| (4) 6-32 x 3/4" BOLT | | PT. #1022 |
| (4) 4-40 x 1/2" BOLT | | PT. #1006 |
| (6) 6-32 BLIND MOUNTING NUT | | PT. #1124 |
| (2) #6 x 3/4" FLAT WASHER | | PT. #1144 |
| (4) #6 FLAT WASHER | | PT. #1140 |
| (2) 6-32 x 1-1/4" BOLT | | PT. #1024 |
| (3) 1/8" O.D. x 24" NYLON TUBE | | PT. #5614 |
| (2) CONNECTOR BODY | | PT. #1375 |
| (1) NYLON SNAP-NUT | | PT. #1461 |
| (2) #2 x 5/16" SHEET METAL SCREW | | PT. #1086 |

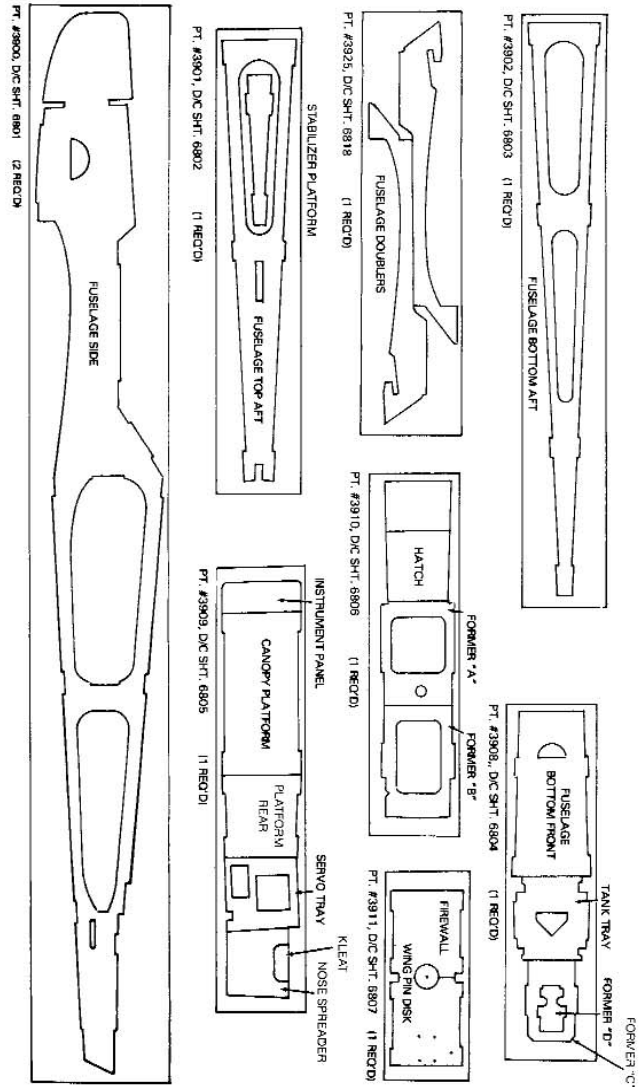

2. SUPER JET glue the two 1/8" ply FIREWALL parts together. Keep the center points and centerline facing out. Make sure that all of the edges are in line. Tape them together and place them under a weight until they are dry.

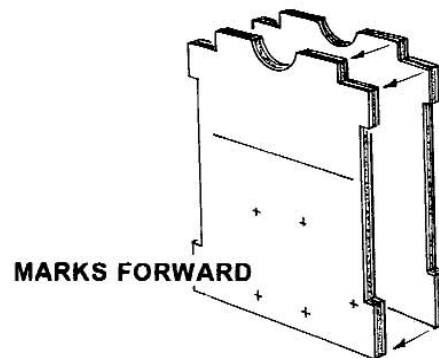

3. Tack-glue the motor that you intend to use to the **MOTOR MOUNTS**. Do not position the engine tight between the two mounts. Leave a 1/16" gap on each side to allow engine side thrust adjustment. Center the assembly on the firewall and align the mark on the mount to the centerline on the firewall.

Mark the hole locations onto the **FIREWALL**.

Drill a 5/32" diameter holes at the four motor mount locations. Refer to **PLAN**.

4. Drill 1/8" diameter holes at the 4 **STEERING BEARING** locations, and also at the steering guide location.

On the marked side, insert the four 4-40 **BLIND NUTS** for the steering bearing. Insert the four 6-32 **BLIND NUTS** for the **MOTOR MOUNTS**. Seat them into the firewall, using a few soft blows with a hammer.

Generously coat the edges of each nut with **SUPER JET** glue.

5. Bolt the **STEERING BEARING** to the firewall using four 4-40 x 1/2" **BOLTS** with **WASHERS**. Note that the short bearing is to the bottom.

6. Lay the **FUSELAGE SIDES** on a flat surface, side-by-side, so they are mirror images. This will insure that you build a left and right fuselage side.

Glue a **FUSELAGE DOUBLER** to each side, aligning the front and rear corners for proper positioning.

Glue the **NOSE DOUBLER** to each side, using the front edge of the motor mount as a guide.

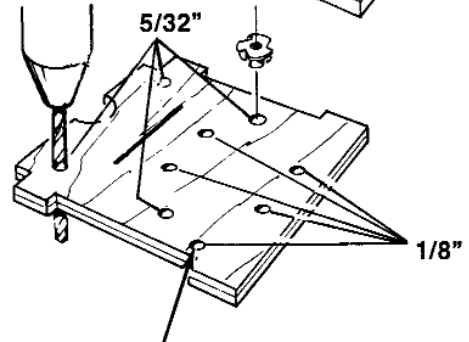
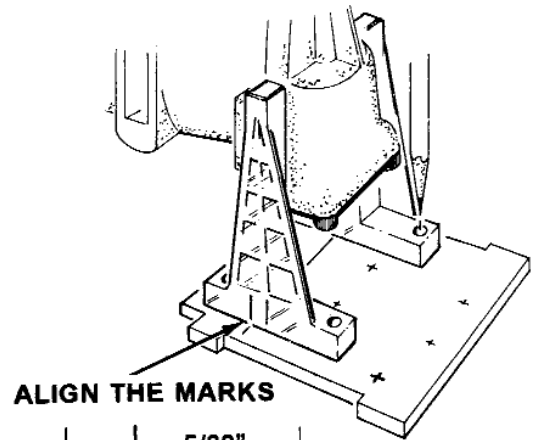

THIS HOLE FOR STEERING GUIDE TUBE

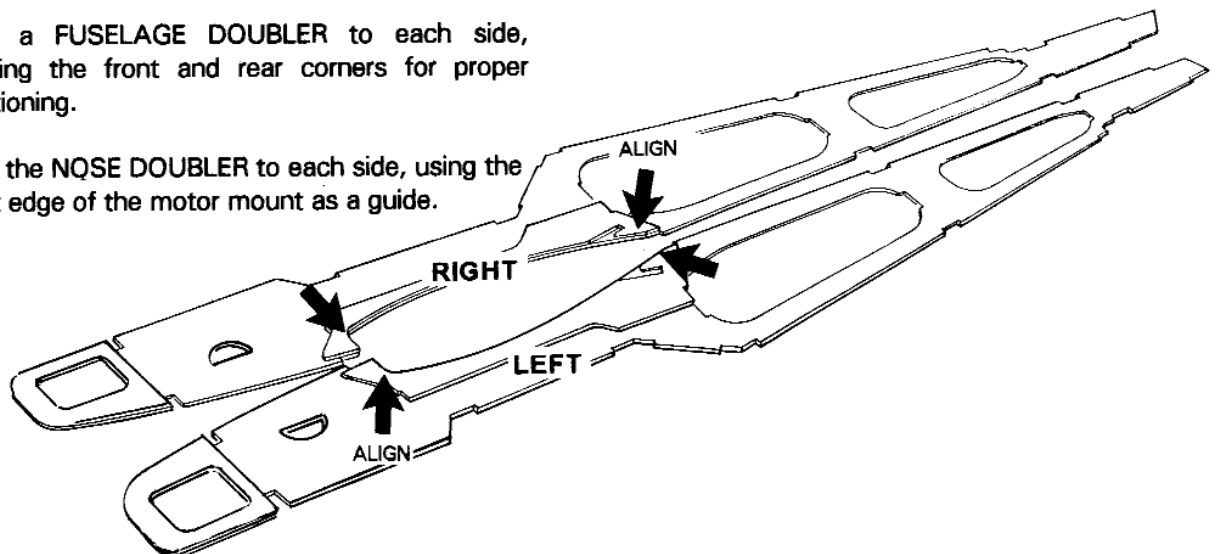
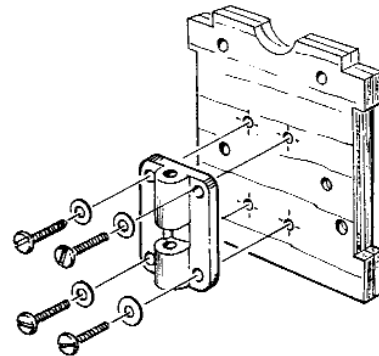

7. Use rubber bands to hold the parts together. Assemble the fuselage sides, firewall (steering bearing forward), and all of the formers. Place a 1/4" balsa scrap at the tail. **Do not glue anything yet!**

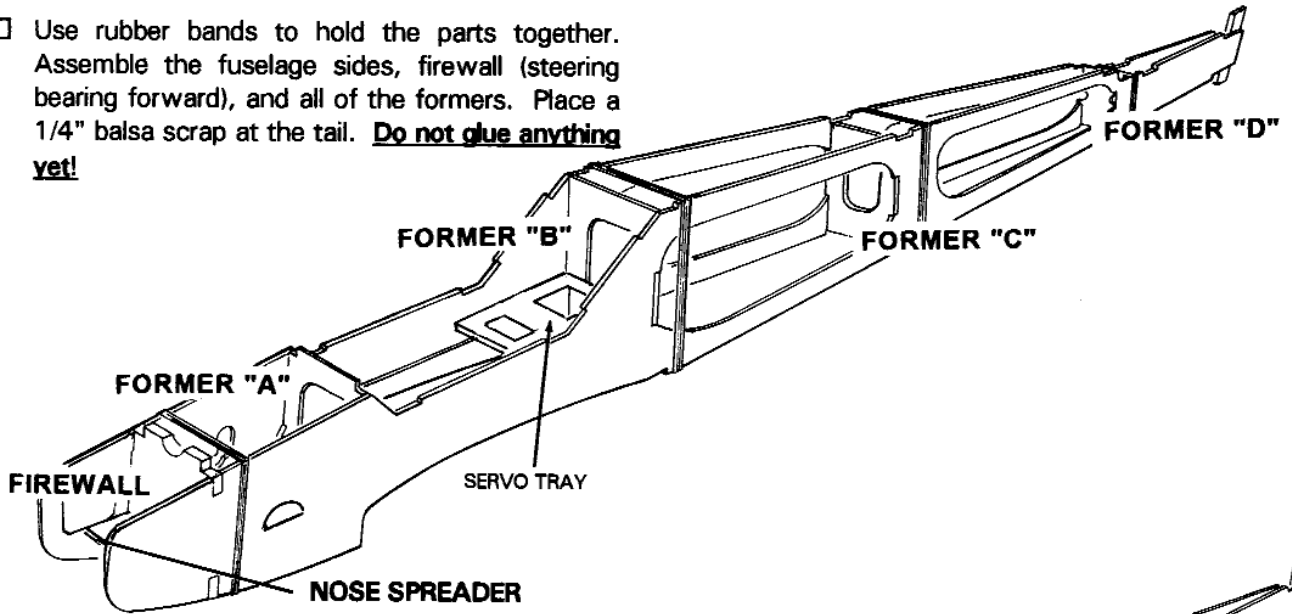

8. Glue the two RAILS to the sides.
- Slide the FUSELAGE TOP AFT under the rubberbands and into the notches, but **do not glue!**

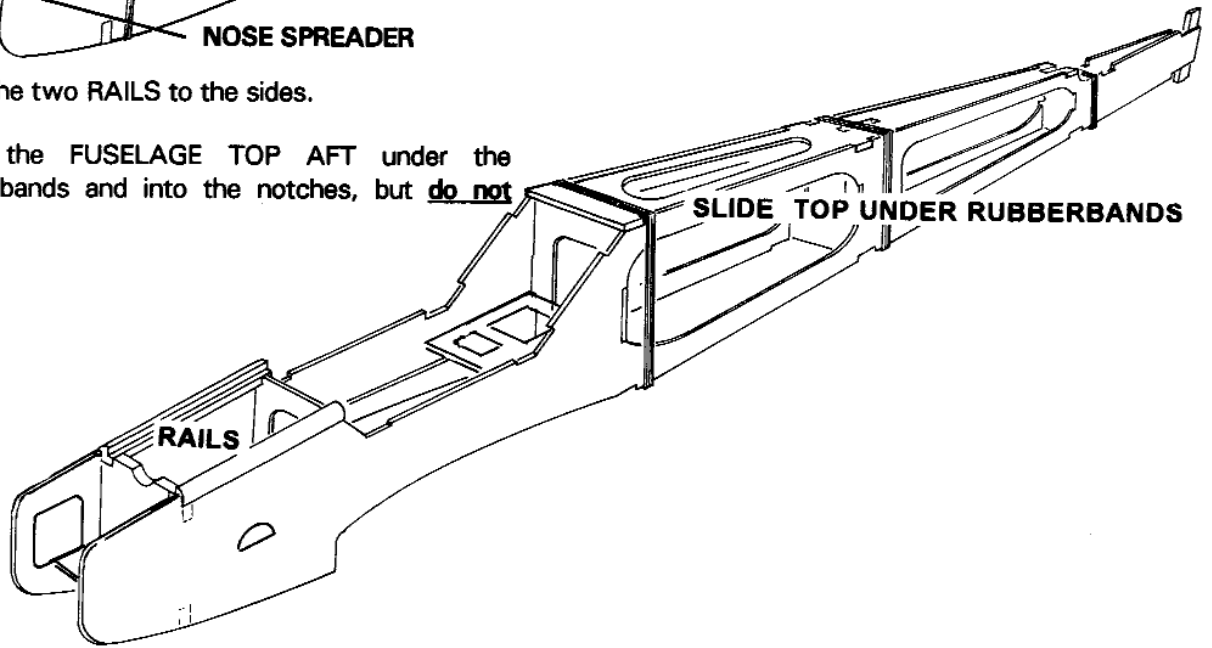

9. Flip the fuselage over and slide the FUSELAGE BOTTOM FRONT and AFT under the rubber bands, but **do not glue.** It may be necessary to add a few more rubber bands to the front to pull up the bottom sheet.
- Install the 1/8" O.D. x 24" NYLON TUBE.

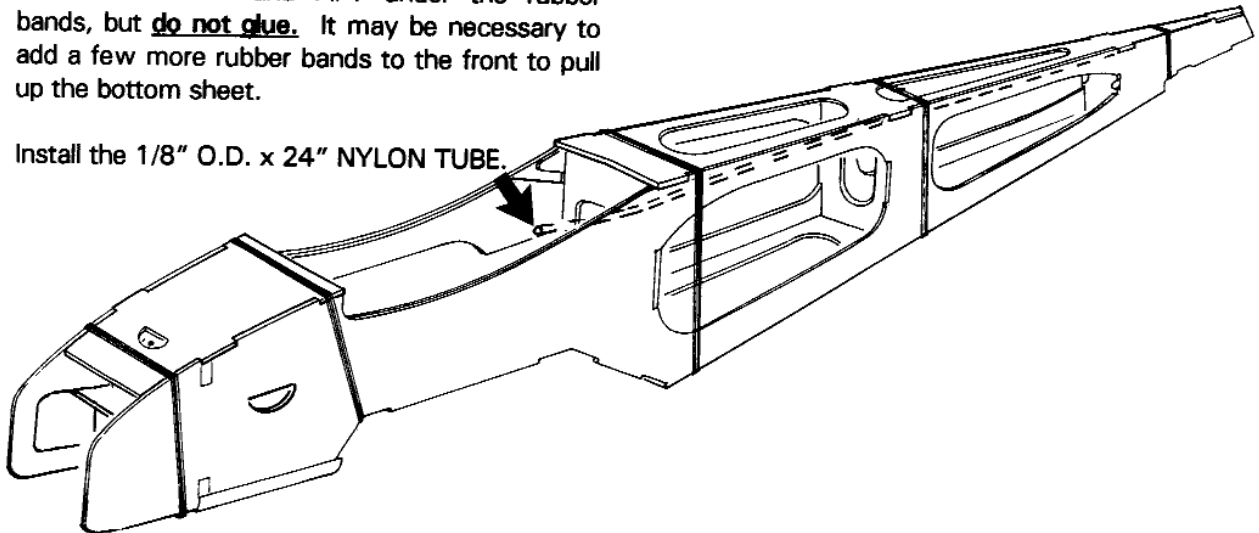

10. Stack the two 1/4" ply WING MOUNTING BLOCKS together.

At the location shown, drill a 5/32" hole through both parts.

Insert a 6-32 blind nut into each hole. Tap the flange with a hammer to seat the spurs into the wood.

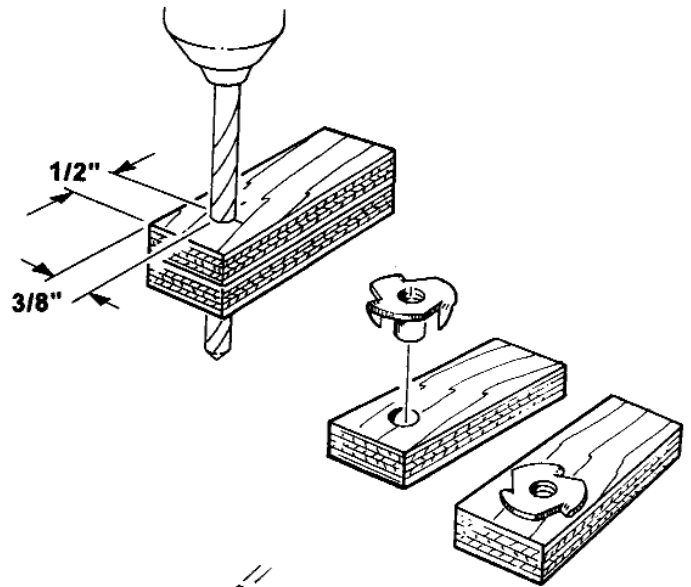

11. With the blind nut flanges to the inside, securely glue the wing mounting blocks in place.

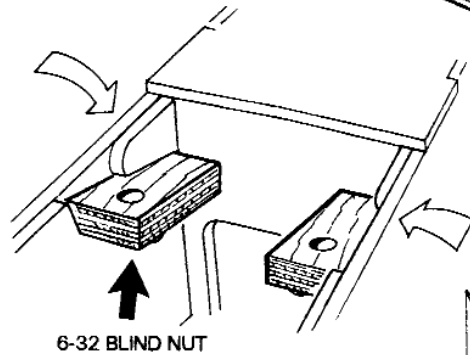

12. Position the fuselage directly over the plan. Use a triangle to check the alignment. When you are satisfied with the alignment, glue all the joints and seams by reaching in through the openings.

Double check the entire fuselage to make sure all the seams are securely glued.

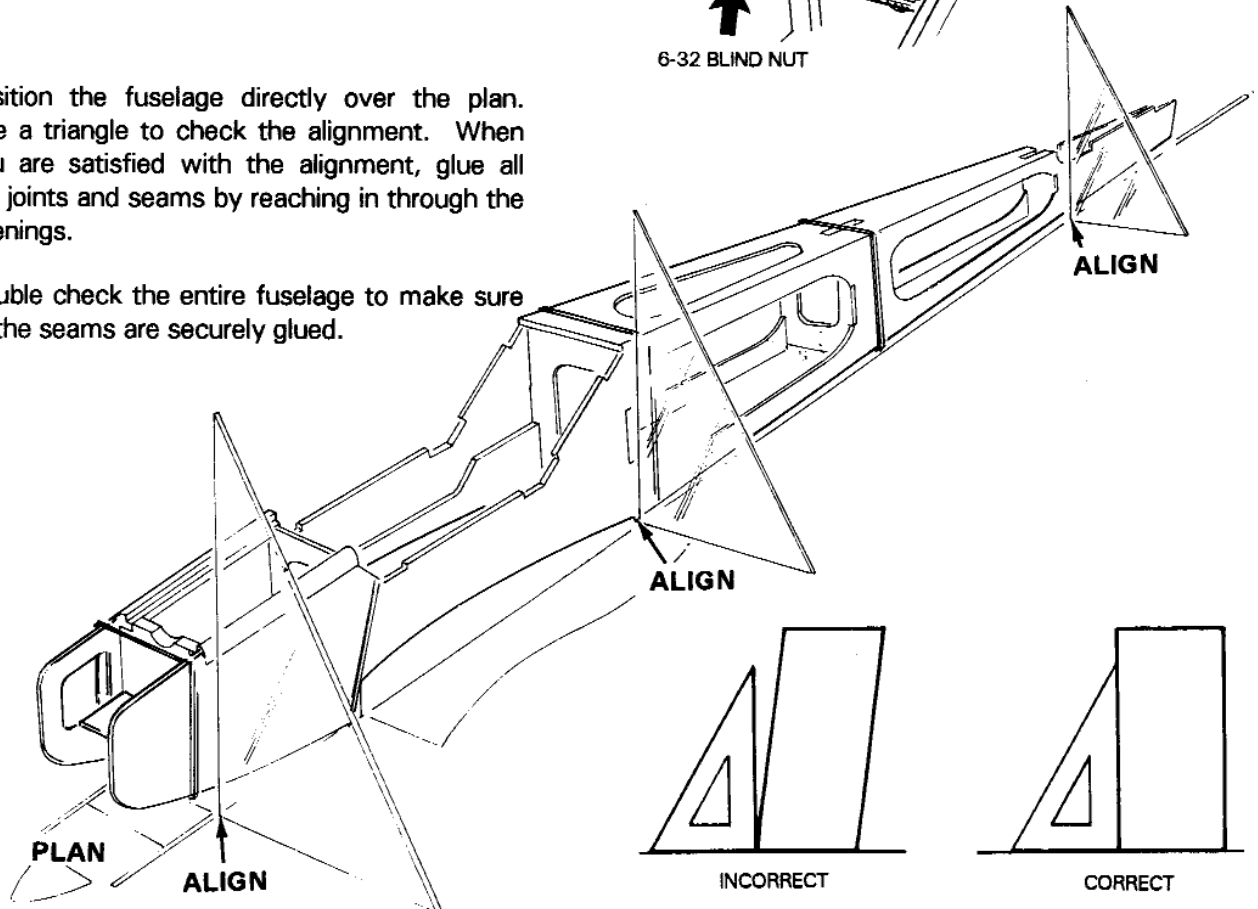

13. Install the STAB PLATFORM. Check the alignment and glue in place.

14. Drill a 5/16" hole at the centermark in the WING PIN DISK.

15. Get the wing, which will be needed for this step.

Place the fuselage onto the wing, with the wingpin through the former.

With the wing fitting the saddle tightly, adjust until the two diagonal dimensions are equal. Mark the position and tape in place.

Place the disk doubler on the wing pin and then glue it to former "A". Make sure the wing remains tight against the wing saddle.

WARNING: DO NOT GLUE THE WING PIN TO THE DISK.

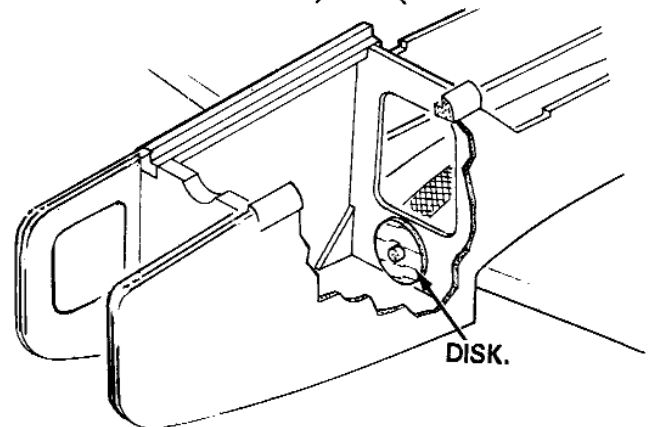
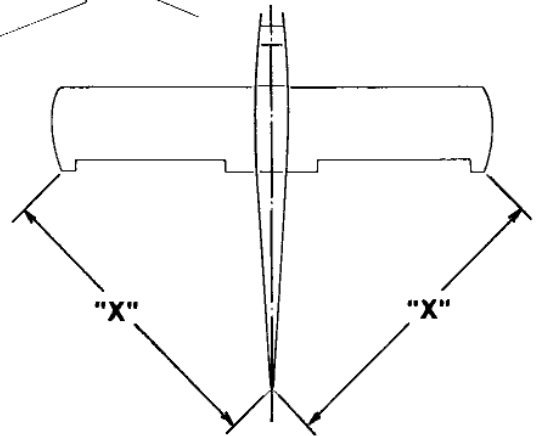
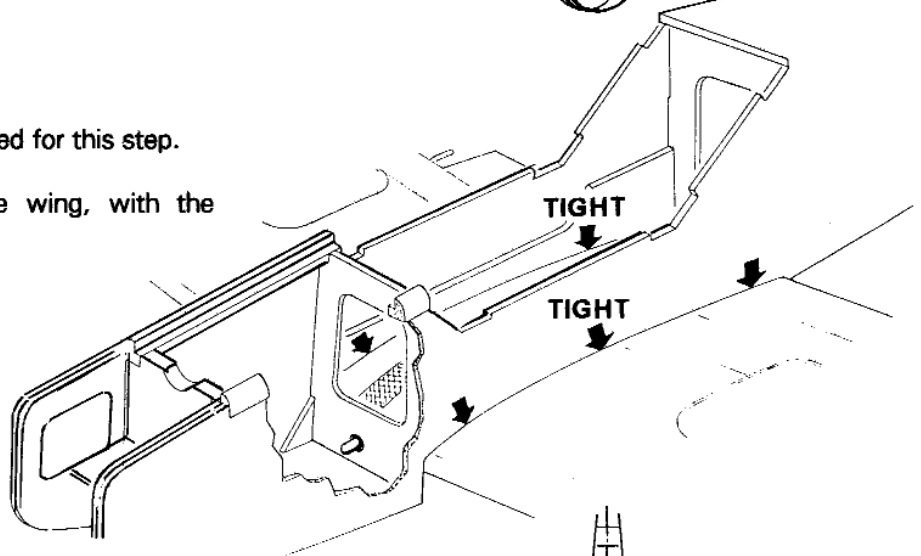
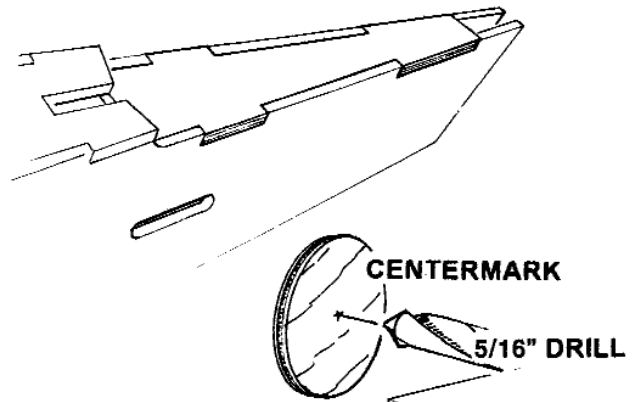

16. Use a long drill bit, no larger than 7/64" diameter, to drill a pilot hole through the wing. Use the blind nuts as locators.

Note: The aileron pushrod works great as a drill bit, if you chisel cut the plain end.

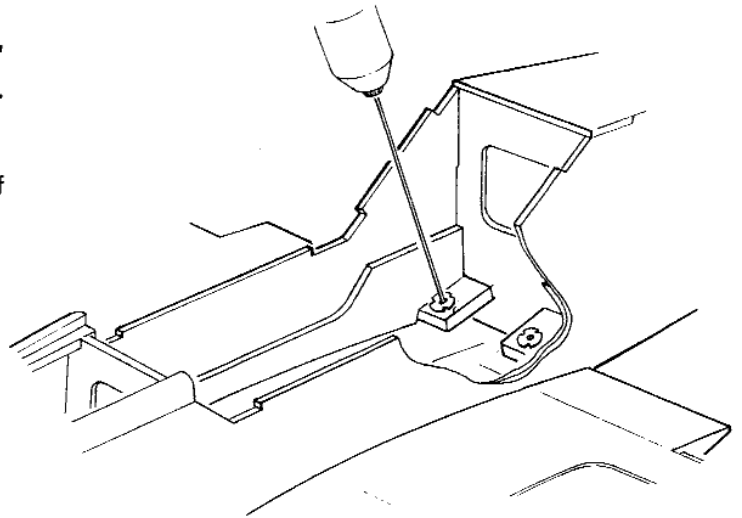

- Remove the wing from the fuselage and drill a 5/32" hole through the wing, using the pilot hole as a guide. Test bolt the wing to the fuselage and check the diagonal dimensions again.

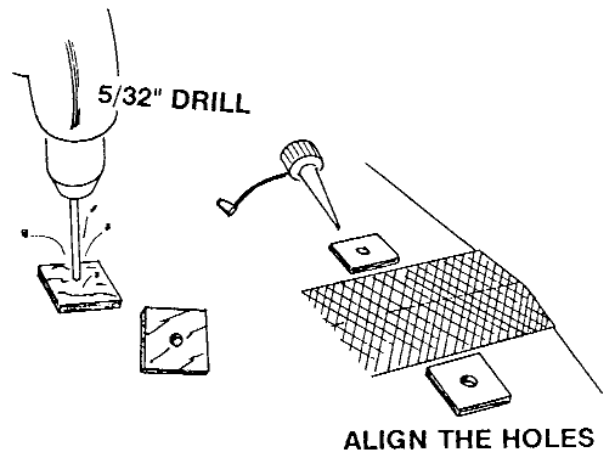

17. Drill a 5/32" hole at the centermark on each WING BOLT PAD. Use a wing bolt to locate and glue the pad to the wing.

CORNICE PARTS

18. With the wing square and firmly bolted in place, build the gussett onto the wing.
- Install the front piece above the L.E., then glue the sides to the wing. Use the top to gauge the side position.
- Install the top and lightly sand to blend to the fuselage.
- Feather the transition with balsa tinted MODEL MAGIC. You may want to fill this in 3-4 applications, sanding between each.

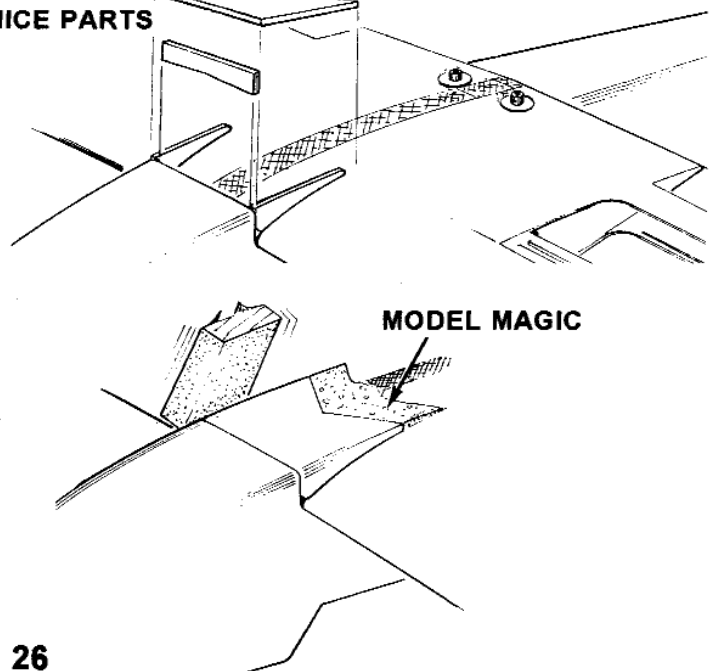

19. Sand the shaped rails in line with the instrument panel angle.

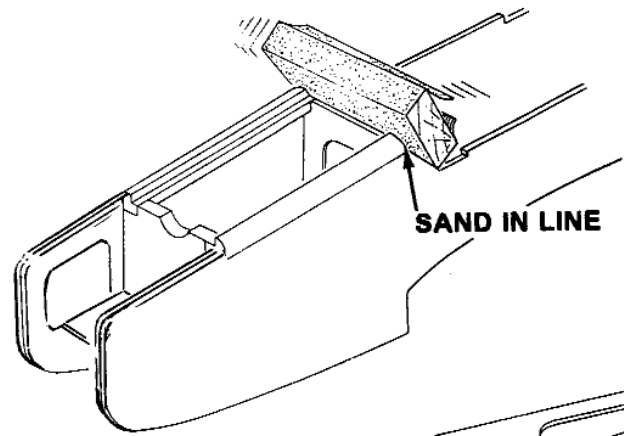

20. Install the CANOPY PLATFORM and the INSTRUMENT PANEL.

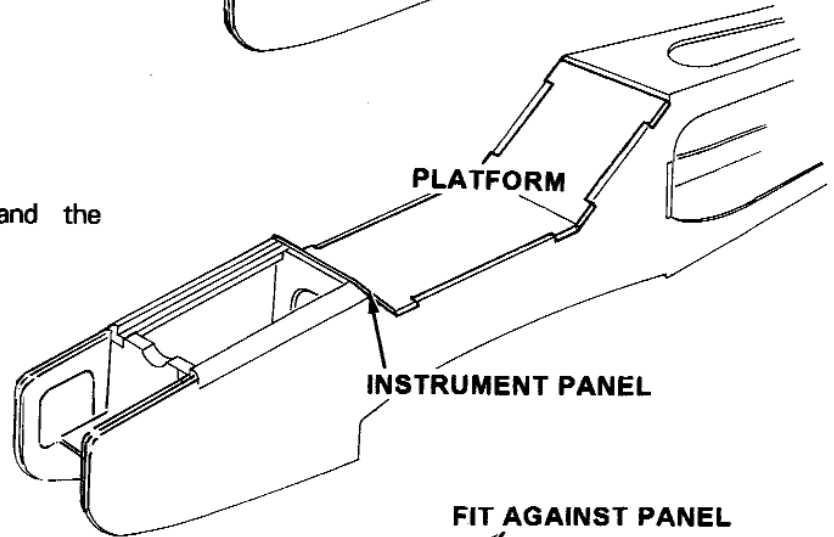

21. Install the FUSELAGE TOP FRONT onto the rail shoulder and against the instrument panel.

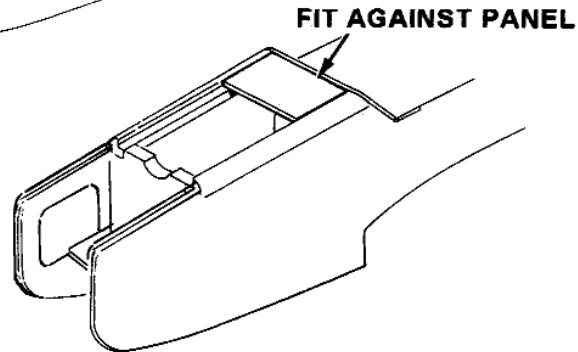

22. Sand the entire fuselage, first using medium grit and then switching to fine. Remember that covering will not hide a rough surface.

- Coat the firewall with JET GLUE. Be careful not to let glue get into the threaded blind nuts.

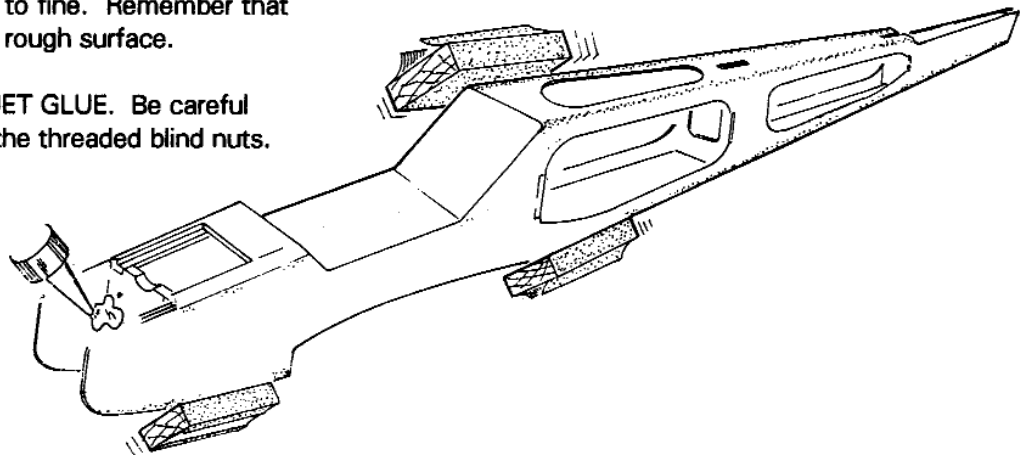

23. Make an elevator and rudder pushrod, using your plan as a guide.

24. Install the motor mounts and position the engine.

- Install a CONNECTOR BODY to the throttle arm and secure it with a NYLON SNAP NUT.

- Mark the location of the throttle pushrod exit.

- Drill a 1/8" hole and insert a nylon guide tube.

- Install the remaining tube in the hole for the steering arm at this time.

Rough-cut both tubes to length now. Finish-cut when you install the radio.

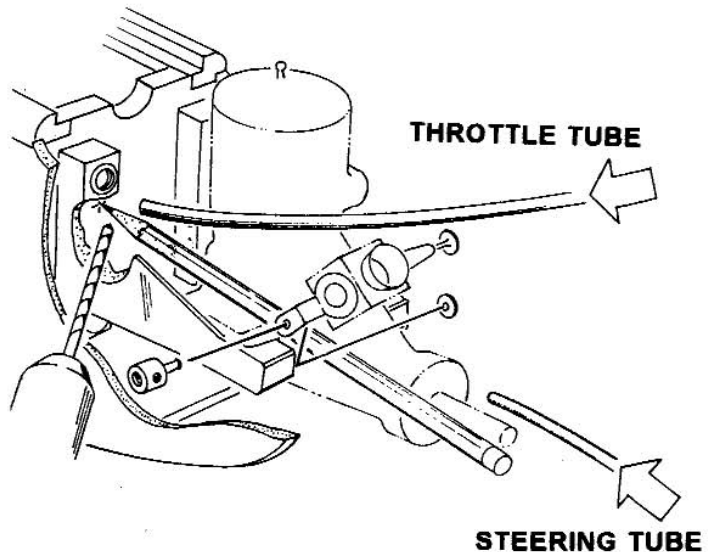

25. Glue a lite ply kleat to the hatch.

- Drill a 3/32" hole at the two centermarks. Test-fit the hatch onto the rail and temporarily secure the two #2 x 5/16" screws.

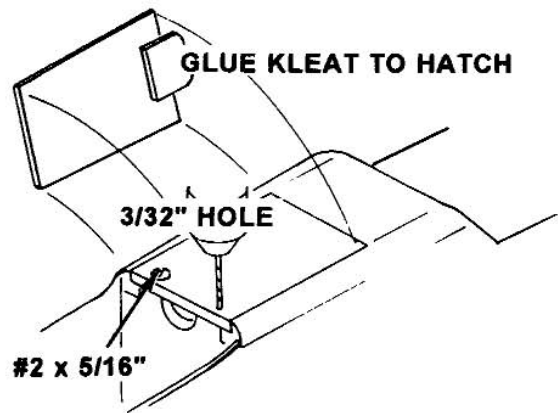

THIS COMPLETES THE BUILDING PORTION OF YOUR TIGER 60.

MAKE SURE THAT ALL THE PARTS ARE SANDED AND THAT ALL THE NICKS ARE FILLED. REMEMBER THAT THE COVERING MATERIAL WILL NOT HIDE A ROUGH SURFACE.

NOW GO TO THE "COVERING" SECTION IN THE GENERAL INFORMATION BOOK. AFTER THE MODEL IS COVERED, RETURN TO THE "FINISHING THE MODEL" SECTION IN THIS BOOLET AND CONTINUE.

FINISHING THE MODEL (11 Steps)

1. Permanently attach the elevator to the stab and the rudder to the fin, using INSTANT JET to glue the hinges. See page 31 for JET HINGE instructions.

2. Remove a portion of the covering to provide a wood-to-wood bond and glue the stab to the platform. Make sure that the stab is properly aligned in both the top and rear views.

WARNING: BE VERY CAREFUL NOT TO CUT INTO THE WOOD STRUCTURE WHILE TRIMMING THE COVERING.

3. Glue the fin into place. Check the fit-up at all contact points and make sure that the elevator connecting wire has enough clearance from the inside of the rudderpost. Check the rear view for proper alignment.

4. Assemble the steering arm and slide the gear strut into the bearing, positioning it so that the coil clears the bottom of the fuselage. After you have determined the correct position, slide the strut out and file a flat in the strut for the set-screw to seat. Reassemble and secure.

5. Mount the engine with the proper right thrust. See the plan for the correct orientation. Drill a 1/16" pilot hole for each #6 x 3/4" mounting screw.

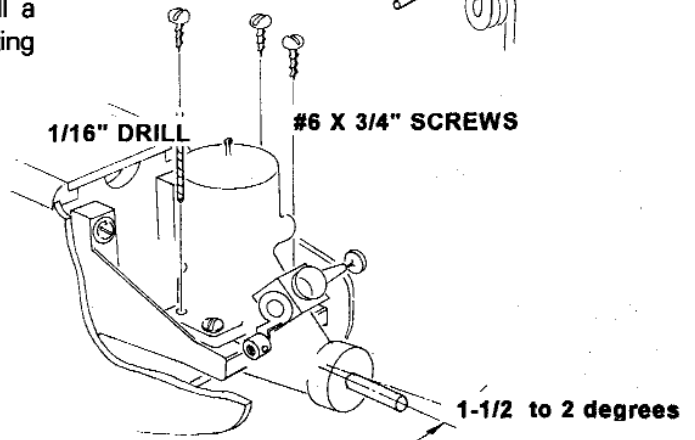
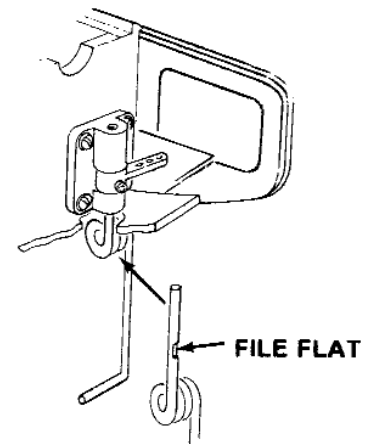
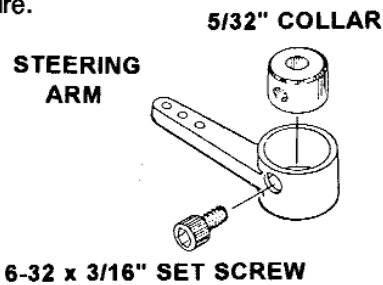
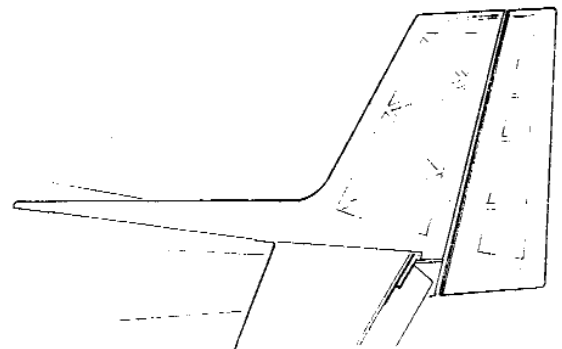
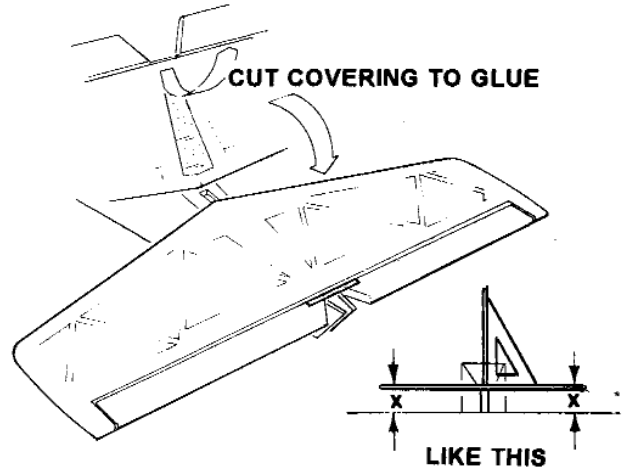

6. Apply the instrument panel decal.
- Trim the canopy to the scribe line and epoxy glue into place. Be very careful and do not use too much glue for this application.

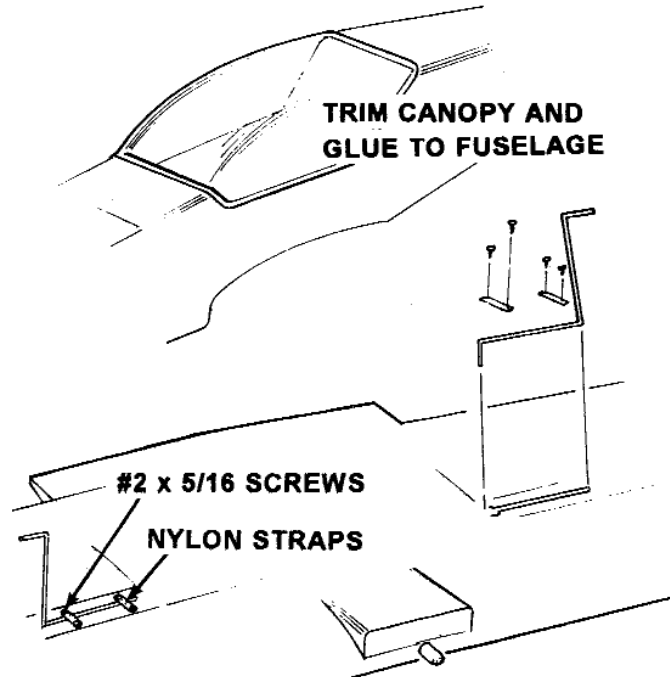

7. Now, let's finish the wing.
 - Install the main landing gear wire down into the slot. Use two nylon straps and four #2 x 5/16" screws per side to secure the wire gear.

You will need to supply one 2-1/2" diameter wheel and two 5/32" wheel collars per axle.

8. Permanently install the ailerons to the wing, using INSTANT JET to glue the hinges. See page 31 for JET HINGE instructions.

- Mount the servo, making sure that the torque rod is 90° to the aileron.
- Thread the SNAP LINKS onto the aileron pushrods.
- Attach the Z-bend to the servo and the snap link to the aileron horns.

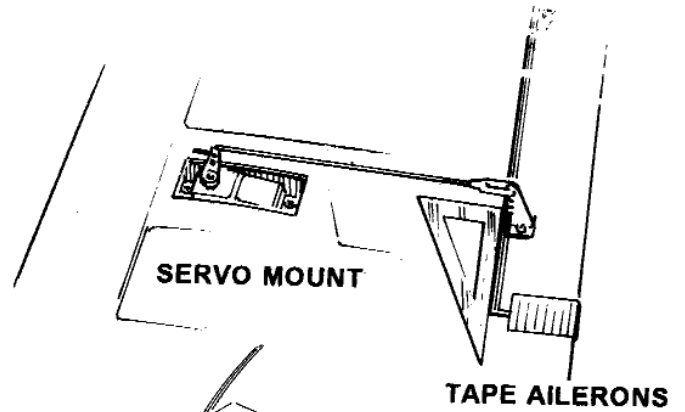

9. Install the TANK TRAY into the slots in the fuselage.
- Rubberband the fuel tank to the tank tray. Remember to insert the foam between the tank and the tray.

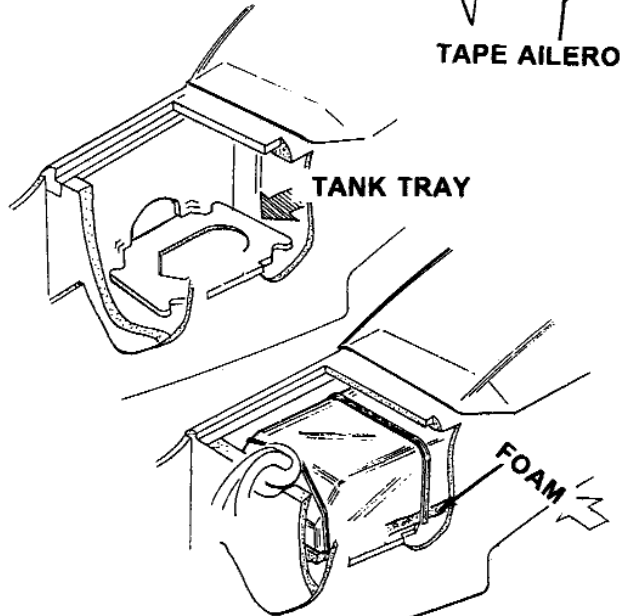

10. Install the radio system. Refer to the **GENERAL INFORMATION BOOK** and the guidelines that came with your radio system for specific details.

11. The location of the center of gravity (C.G.) is **very** important. Refer to the **PLAN** for the location and to the **GENERAL INFORMATION BOOK** for the balancing procedure.

SLIDE TANK UNDER RUBBER BANDS

CONTROL SURFACE TRAVELS

Cover all hinge gaps with matching color or clear cellophane tape. Read all JET HINGE instructions before final assembly.

Use the control surface travel gauges to correctly set up the surface deflections. The gauges provide you with two settings, a gentle response setting and a more aerobatic setting. We encourage you to start out using the gentle marks and to move to the aerobatic mode as you progress. If you are using a computer radio, set the transmitter to 100% and adjust the travel settings at the servo arm.

AILERON TRAVEL GAUGE

1. Place the gauge anywhere along the wing. Align the center of the aileron to the mark in the neutral position.
 - With the control stick full left and right, match the center of the aileron to the mark.
2. Adjust the horn bracket as high as possible on the torque rod and position the pushrod in the hole on the servo arm to achieve the desired surface travel.

Note: This is a good time to check and make sure the control surfaces go the correct way. You wouldn't want to correct a left bank with more left, so check it now!

ELEVATOR TRAVEL GAUGE

1. Place the elevator gauge anywhere along the elevator hinge line.
2. Clip the pushrod to the end hole on the control horn.
 - Position the servo end of the pushrod in the hole on the servo arm to achieve the desired surface travel.

RUDDER TRAVEL GAUGE

1. Position the rudder gauge at the top of the fin at the hinge line. Follow the same procedure used for the elevator to realize your desired travel.
 - Connect the steering pushrod to the servo. Check the plan for proper orientation.

YOU HAVE COMPLETED THE CONSTRUCTION OF YOUR TIGER 60. NOW GO TO THE **GENERAL INFORMATION BOOK** AND READ THE "FLYING" SECTION.

JET HINGE INSTRUCTIONS

- Use your CG Hinge Marker to mark the center of the wood surfaces to be joined.
- Carefully cut a slot approximately 1/2" deep and slightly wider than the hinge, using your favorite knife blade.
- After all slots have been made, mark the center of your hinge and insert pin (see illus.). This will hold the hinge in place while sliding the matching part (aileron, etc.) onto the JET HINGE. **Do not glue!**
- With both surfaces hinged and assembled, check the alignment. For good control response, the hinge gap should be as small as possible, but should allow for full deflection when needed.
- When satisfied that all is aligned and working properly, remove pin. Apply 3 or 4 drops of thin JET CA glue to the exposed JET HINGES. Turn over and apply another 3 or 4 drops to the hinge line of the other surface.
- Allow 10 minutes for the CA to cure, before flexing the surface.
- Work the surface up and down to remove any stiffness you may feel.

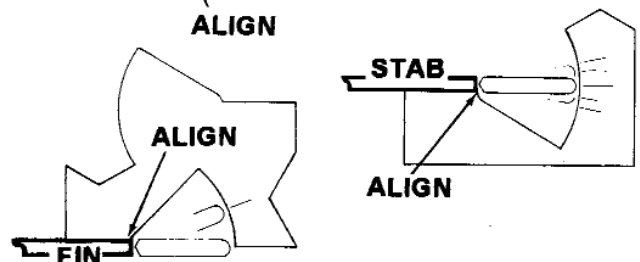
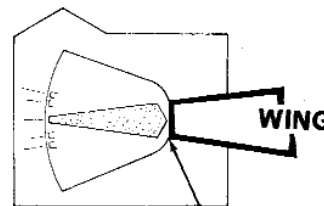
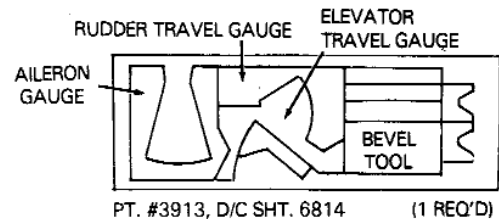
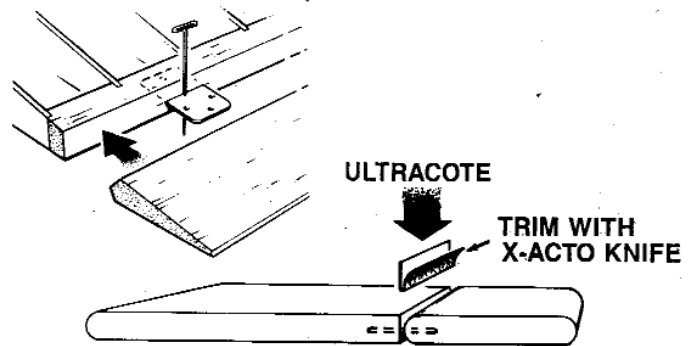

Redesigning the Tiger 60 For Tail dragger version.

Installing the Main gear block

The Main Gear needs to mount onto the fuselage in front of the wing saddle. The current 1/8" Lite plywood needs to be reinforced by using a 1/4" thick piece of birch plywood. Place the 1/4" birch plywood inside the fuselage in front of Former "A" and run towards the engine 2-3/4". Across the top front of the 1/4" birch gear block, make a former the goes across the fuse side to help support the front of the gear block. Use lots of epoxy and small triangle stock to help support the gear block.

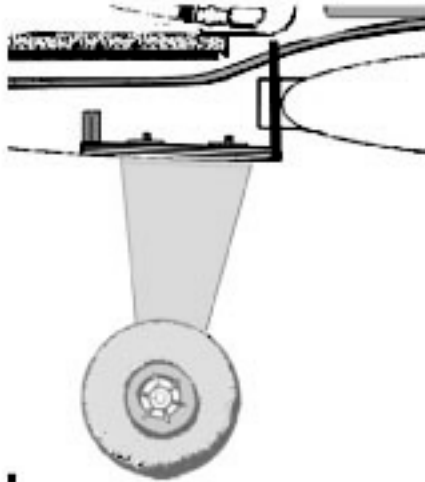

Installing the Tail Gear

In the rear of the fuselage, install a 1/8" birch plywood support inside the fuselage. Make the support 3" long and install any blind nuts before the fuse is finished.

