

# Super Chipmunk

## Instructions



Another loop, roll and then a plunge earthward into a dive trailing billowing white clouds of smoke. Perilously close to the ground it pulls out and zooms a few hundred feet into a hammerhead stall. No, it isn't Art Scholl performing at a summer airshow, its the C.G. version of his Super Chipmunk at a R/C fun-fly. We've dedicated our model of the Super Chipmunk to the memory of its designer and creator, Art Scholl. His breathtaking precision aerobatics demonstrated to millions the safety and grace of disciplined flying.

Our Super Chipmunk's super-stable, low speed manners let you fly at a crawl and it simply won't quit. Bring it in a little nose high, and you'll still have solid control to a perfect touch-down. Turn it loose and this performer will put on a airshow with all the flash and flair of the original.

### Additional Items Needed:

- 4-5 channel radio
- CA glue and epoxy
- .45 to .61 (.90 4-cycle) R/C engine
- 2-1/4" CGP snap-on spinner
- Propellers, fuel tank and tubing to suit engine.
- 14 running feet of covering material
- Paint
- One 1-1/4" and two 3-1/4" Wheels
- Foam rubber

### Optional Wing Flaps:

- CG 3/32" Strip Aileron Set
- CG True 1/16" pushrods
- 1/8" x 3" x 6" Aircraft Plywood

### Tools & Supplies Needed

- Miscellaneous rubber bands
- Wax paper
- Modeling knife or single edge razor blade
- Sandpaper
- Pins
- Drill sizes:  
1/16", 5/64", 3/32", 1/8", 5/32", 3/16", & 1/4"
- Flat building board
- Pliers
- Small Screwdrivers
- Iron for applying covering
- Masking tape

---

# CARL GOLDBERG PRODUCTS, LTD.

## SELECTING RADIO CONTROL EQUIPMENT

The Chipmunk is designed for 4-channel radio control equipment. Many of the radio systems now available feature "servo reversing" switches which allow you to reverse the response of the servo. This feature simplifies radio installation and is a worthwhile consideration when selecting a radio system.

Adding any of the options (flaps, smoke or retracts) will each require another channel. If you want to add all three options, you will need an additional three channels, requiring a 7-channel radio system.

## ENGINE & PROPELLER

The Chipmunk flies well using any engine size from .45 to .61 (.90 4-cycle) cubic inch displacement. If you live in a warm climate, or your flying field is approximately 3,000 feet or more above sea level, you should use a .49 engine or larger. The propeller size must be matched with the engine. For example, a .40 engine may use a 10" diameter prop, while a .61 uses 11". Refer to the prop and fuel tank chart at lower left.

Balancing your propeller helps to protect your radio from the damaging effects of vibration. Good balancers are on the market, and generally are easy to use. We recommend sanding or scraping the heavy blade on the curved face rather than the flat face, and out near the tip. Try to maintain the normal airfoil curvature. And avoid scratches which might cause the prop to break.

## ADHESIVES

All our test models were built using cyanoacrylate glue (C/A) which is specially formulated to firmly glue the plywood, hardwood, plastic, and balsa used in your Chipmunk, and we strongly recommend it. Another good glue to use is "15 Minute Epoxy" or Aliphatic Resin. They will, however, add considerably to the assembly time required (they dry a lot slower than CA glue). Also, aliphatic resin does not glue plastic, so you will need one of the adhesives mentioned above (or similar) for the plastic motor mount installation.

There are a few instances where you may prefer to use one or more of the following C/A glues. For example; when gluing the wheel parts together, thin CA glue penetrates the tightly fitted joints for an immediate bond.

When installing the stabilizer and fin on the fuselage, you might want to use thick CA glue which allows more time for careful alignment and part positioning. Whatever C/A product you use, CA debonder as a solvent which removes hardened glue from fingers and softens glued joints for repositioning of parts.

## WARNING

Do not use watery THIN types C/A glue for general construction of your Chipmunk, especially for plywood and hardwood parts. Thin C/A glues do not glue plywood adequately.

After you have finished gluing the model together, go back and re-glue all the joints for added strength, and just in case some joints may have been missed the first time. Be careful not to use too little glue. Too little leaves a model weak.

Since CA glue almost eliminates waiting for glue joints to dry, you can work straight through and finish each assembly by following the step-by-step building sequence. If you use epoxy, you can save time while waiting for one assembly to dry (the stabilizer, for example) by turning a few pages ahead and starting another part (the fuselage, perhaps). Check-off boxes are provided at each step so you can tell at a glance what steps you have completed.

Be careful when using instant glue to install the canopy, as applying too much glue can sometimes cause fogging to occur. A sure way to avoid fogging is to use either epoxy or special a canopy glue.

**TACK-CEMENTING.** Sometimes it is necessary to temporarily glue a part in place that must later be removed. To provide for easy removal of the part without damage, it should have been glued in place using only a small dab of glue. This is referred to as "tack-cementing" later on in the instructions.

DIGITAL PROPORTIONAL  
RADIO CONTROL

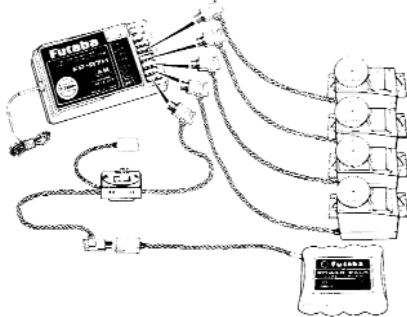
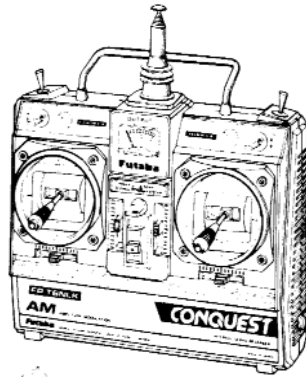

ONE OF MANY SYSTEMS AVAILABLE,  
PLEASE SEE YOUR LOCAL DEALER OR  
CLUB FOR ADVICE ON SELECTING  
YOUR RADIO.

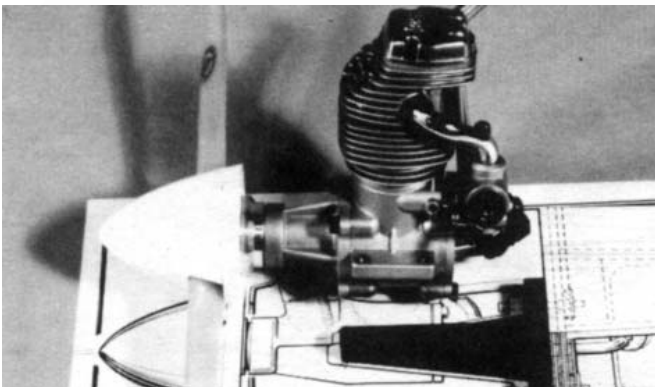

PROP AND FUEL TANK CHART  
NUMBERS IN PARENTHESIS  
REFER TO 4-CYCLE ENGINES

FOR ENGINE SIZE	USE PROP SIZE	AND TANK SIZE
.45-.51	10/6, 11/4, 11/6	8-10 OUNCE
.60-.61 (.60-.90)	12/6 (14/6)	12 OUNCE (10-12)

CA glue sets up a bit slower with plywood and hardwood, so hold such joints together a little longer than you would for balsa. CA glue in corners takes a while longer to dry because it's not a thin layer. The tendency is for all instant glues to set slower on hardwood or plywood and when in a thick layer. By using an accelerator for cyanoacrylate cover greater gaps, speed up slow bonds, and provides glue, strong joint fillets,

**USING EPOXY.** Epoxy comes in two parts which need to be mixed before using. Paper cups and wood coffee stirrers are useful for mixing. When buying epoxy check the package to see how long it takes to set (some formulas set in 5 minutes, others may take hours). We recommend 15 minute epoxy. Disposable wood strips, cotton swabs, cheap stiff bristle brushes, or acid brushes from auto stores make good applicators.

Because epoxy is so thick, it's easy to apply too much. If you use epoxy to build the entire model, be especially careful to use it sparingly when assembling the fin, stabilizer and wings.

#### CAUTION

Some people may experience allergic reactions when exposed to fumes from CA or epoxy. This is very rare. However, it is always important that such glues and also paints, thinners and solvents, be used with adequate ventilation to carry fumes away. A fan is recommended.

#### CANOPY

If a tinted canopy is desired, do not try to dye it (the plastic does not dye well). Instead, we recommend "transparent" spray enamels be carefully applied to the inside surface (they are not fuel proof).

#### COVERING THE MODEL

Many good covering materials are available. We recommend plastic iron on film.

The full-size Super Chipmunk are very colorful airplanes and duplicating their vibrant color schemes can be accomplished several ways using iron on film.

The model can be covered in white and the color scheme added by careful masking and painting with epoxy or polyurethane enamel. or, after covering the model with white the color elements can be cut from red and blue film.

**OPTIONS.** Each of the following options requires one servo for operation.

**FLAPS.** Flaps are a very easy option to add. They will enable even slower landings and steeper approaches. When the flaps are lowered, the model's nose will tend to pitch up slightly. So when lowering the flaps, corresponding down elevator must be applied. Some transmitters have a flap/elevator mixing feature that automatically adds in elevator correction when the flaps are lowered.

**SMOKE.** Many good smoke systems are available. They function by injecting an oil mixture under pressure into the exhaust pipe. When pumped into and mixed with the hot exhaust, the oil vaporizes into billowing clouds of smoke. Because 4-cycle engines run cooler than 2, it helps to pre-heat the oil by wrapping the feed line around the exhaust. Also, for 2-cycle engines, crankcase pressure is used to pump the oil. 4-cycle engines do not develop as high an internal crankcase pressure so they require an external pressure source. Ask your hobby dealer for advice in selecting the best system for your type of engine. A typical smoke system is described on page 29.

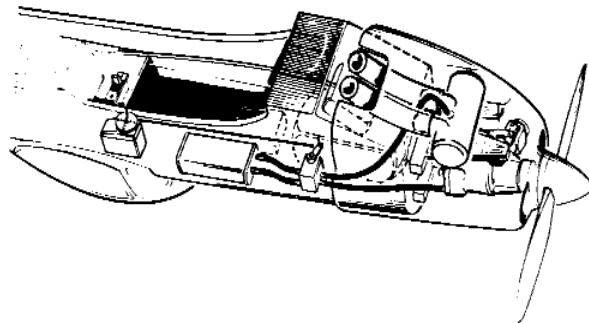

# WOOD PARTS IDENTIFICATION

Be careful when removing parts (such as fuselage sides) from die-cut sheets. Long parts are fragile until glued into a structural unit. If necessary, use a razor knife or razor saw

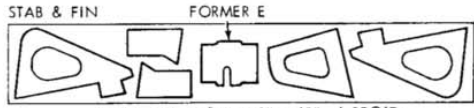

SHEET 5211 3/16" x 3" x 18" 1 REQ'D

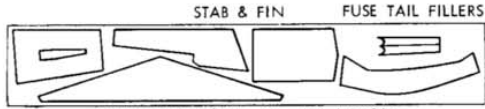

SHEET 5210 3/16" x 3" x 18" 1 REQ'D

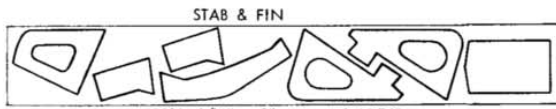

SHEET 5220 1/16" x 3" x 24" 2 REQ'D

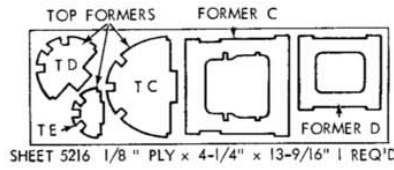

SHEET 5216 1/8" PLY x 4-1/4" x 13-9/16" 1 REQ'D

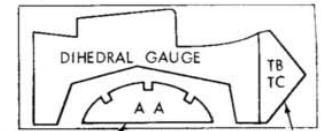

SHEET 5225 1/8" PLY x 4-1/4" x 10-1/2" 1 REQ'D

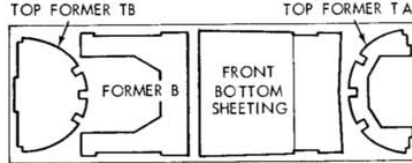

SHEET 5217 1/8" PLY x 5-3/16" x 15-7/8" 1 REQ'D

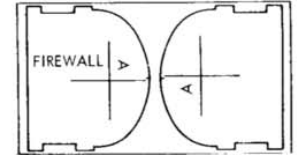

SHEET 5221 1/8" PLY x 5-7/8" x 10-1/2" 1 REQ'D

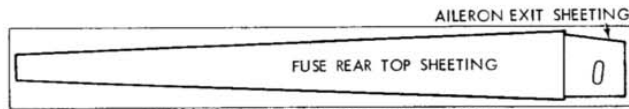

SHEET 5201 5/64" x 2-7/8" x 24" 3 REQ'D

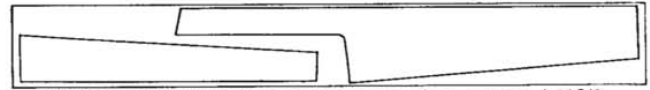

SHEET 5202 1/8" x 3" x 24" 2 REQ'D

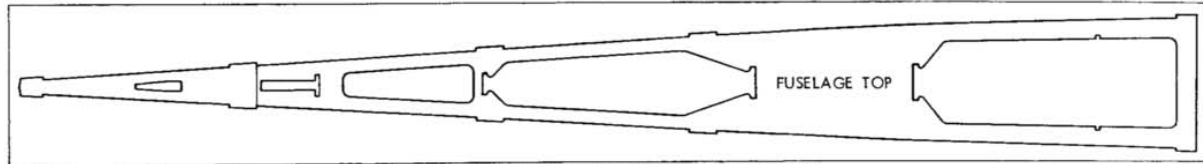

SHEET 5215 1/8" PLY x 5-7/8" x 45-3/8" 1 REQ'D

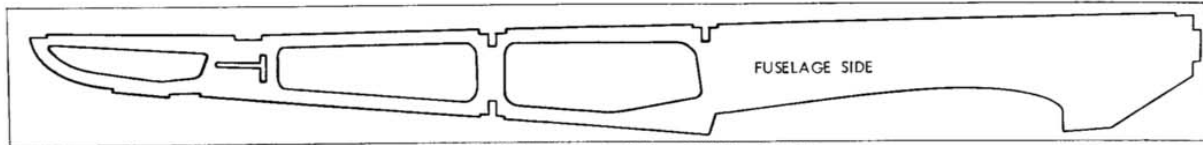

SHEET 5212 1/8" PLY x 5-3/16" x 45-1/2" 2 REQ'D

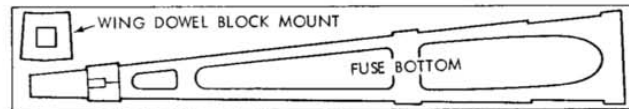

SHEET 5214 1/8" PLY x 3-7/8" x 23-7/8" 1 REQ'D

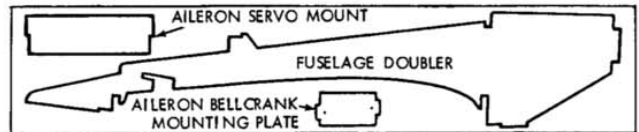

SHEET 5213 1/8" PLY x 4-11/16" x 23-7/8" 2 REQ'D

## FULL SIZE END VIEWS OF STRIP WOOD PARTS

### TAIL ASSEMBLY

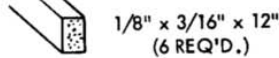

### RUDDER & ELEVATOR

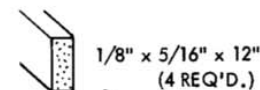
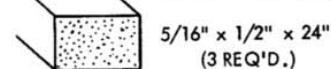

### WING ASSEMBLY

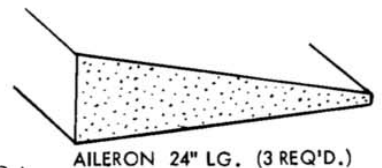
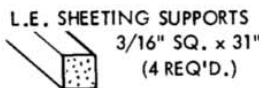
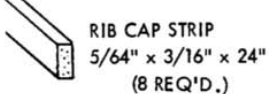
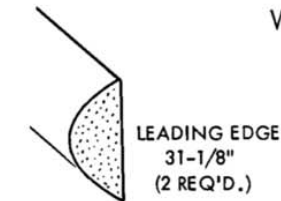

### FUSELAGE ASSEMBLY

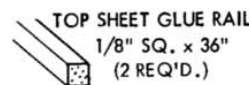
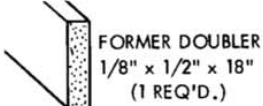

to assist in the removal of parts from sheet. Sometimes a little trimming and sanding can improve parts where desired. Save scrap until model is completed, in case you

should miss a part. Scrap is used also in some building steps on the plan.

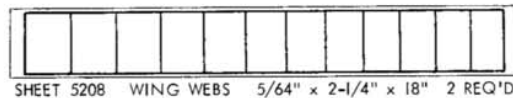
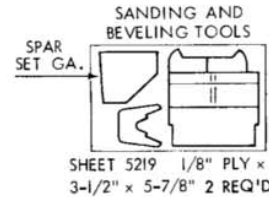
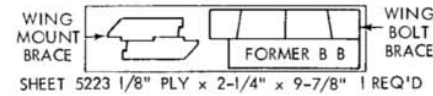
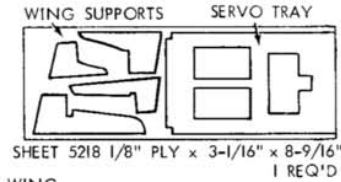
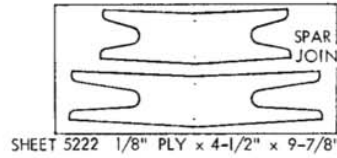
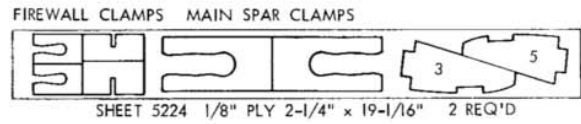
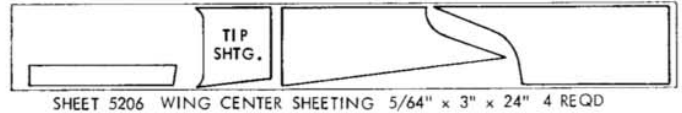
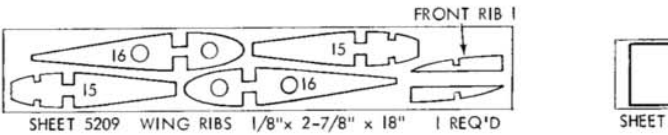
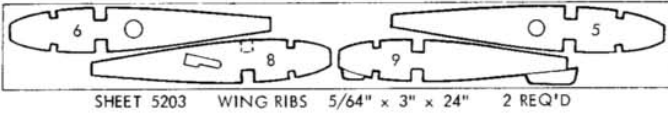
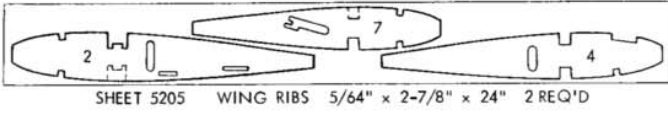
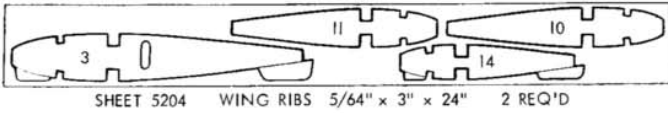
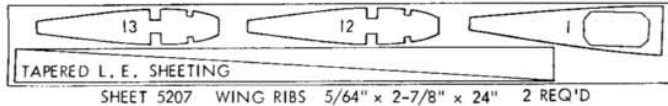

BEFORE STARTING ASSEMBLY OF MODEL, read instructions carefully and construct your model in the following order:

- I. TAIL ASSEMBLY
- II. WING
- III. FUSELAGE

**I TAIL ASSEMBLY**

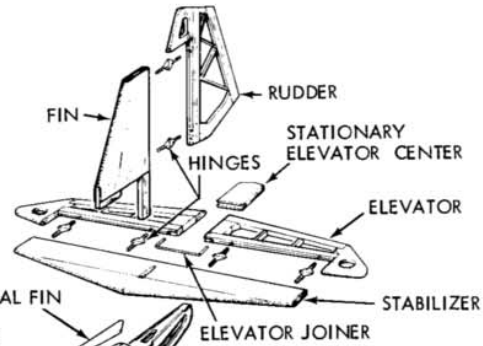

**II WING ASSEMBLY**

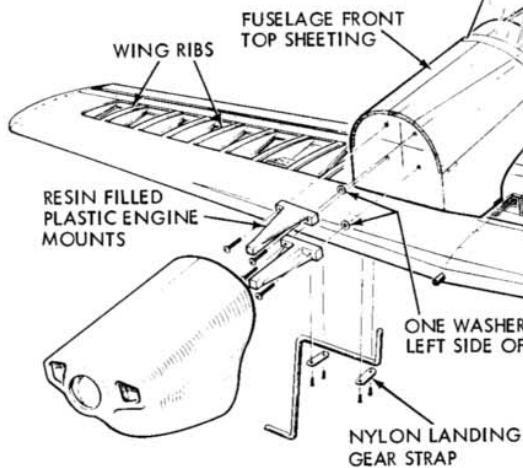

**III FUSELAGE ASSEMBLY**

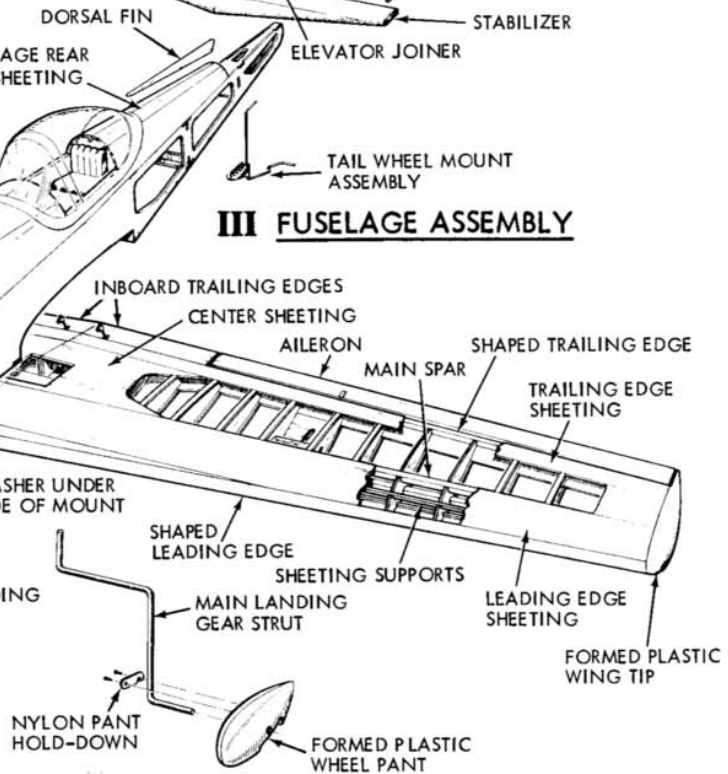

**MAJOR PARTS & COMPONENTS SHOWN HERE BEFORE COVERING**

# ASSEMBLING TOOLS

## Die-cut beveling tools (from 1/8" ply)

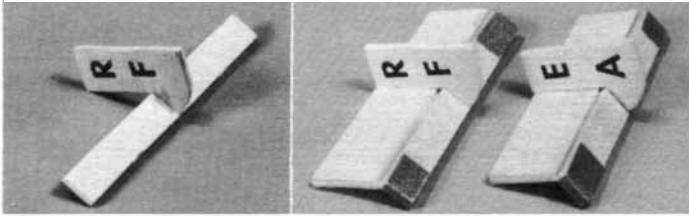

1.  First, glue narrow strip to handle, keeping them square, as shown above left. Then glue wide strip to handle and narrow strip, again keeping things square.

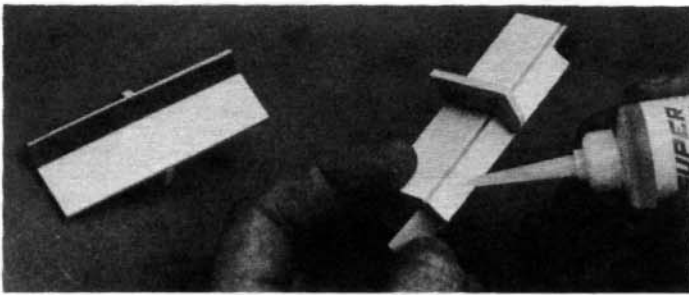

CUT TWO STRIPS SANDPAPER THIS SIZE

2.  Cut two strips of 100-200 sandpaper to size shown above. Tack-cement sandpaper to tools as shown.

## DIE-CUT SANDING TOOL



1.  Glue one strip into handles notches keeping them square. Then glue remaining strip to other half of handles.
2.  Cut one piece of 100-200 grit sandpaper to size of 2-1/4"x3".

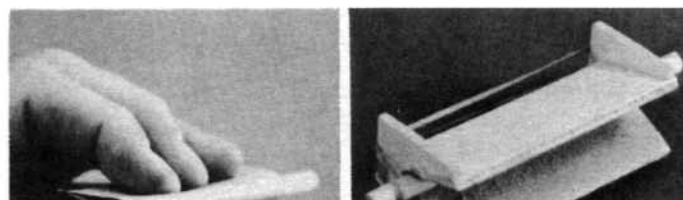

- Center 1/4" dowel over grit side of sandpaper. Roll sandpaper around it as shown above left.
- Slide dowel and sandpaper into tool and hold with rubber band as shown at right. Glue sandpaper to tool.

# TAIL ASSEMBLY

The stabilizer and fin are sheathed with 1/16" balsa, and their interior frames are 3/16" thick balsa. The elevator and rudder are not sheathed, and their frames are 5/16" balsa. For clarity, the stabilizer and fin are built first and then the elevator and rudder.

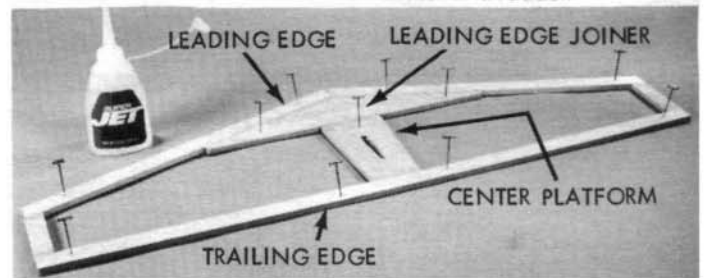

1.  Make stabilizer (stab) leading edge (LE.) from 3/16" x 1/2" balsa sticks. Cut balsa carefully to match with plan at center joint and exact length at tips.
  - Pin in position, and glue at center joint.
  - Using die-cut L.E. joiner, center platform, and 3/16"x1/2" balsa, glue outline together.

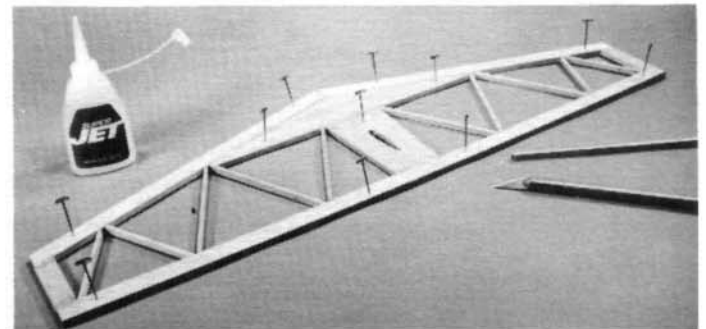
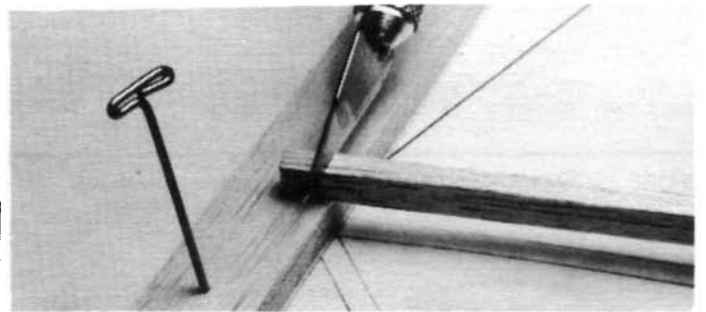

2.  From 1/8" x 3/16" strip balsa, cut all trusses to size over plan. Trim well-don't force into place. Glue in place.
  - Let dry thoroughly.
3.  Assemble fin in same manner as stab, using die-cut and stick parts.

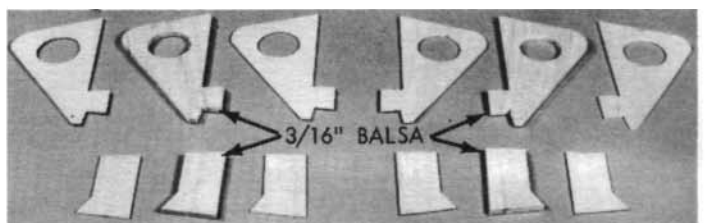

4.  The die-cut balsa parts for elevator and rudder must be

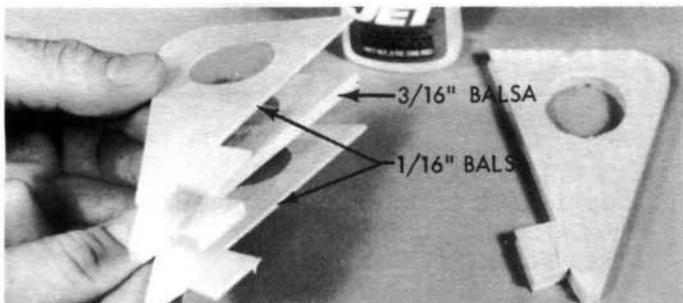

Begin by gluing a 3/16" core between 1/16" top and bottom pieces. In this manner make two elevator tips and two inner ends as show



- Laminate rudder pieces in same manner.
- Laminate center section.

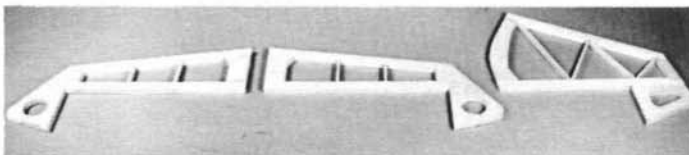

5.  Assemble elevator halves and rudder in same manner as stab and fin, except use 5/16"x1/2" balsa for L.E. and 1/8" x 5/16" for trusses.

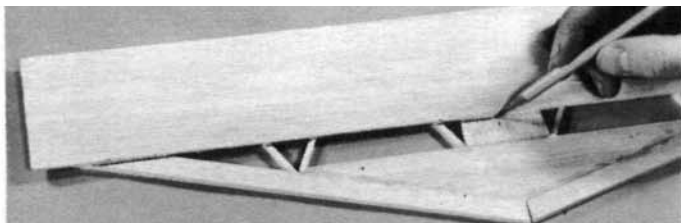

- 6a.  Flush edge of 1/16"x3"x24" balsa sheet even with stab T.E. and allow a little extra at tip for trim off. Mark sheet

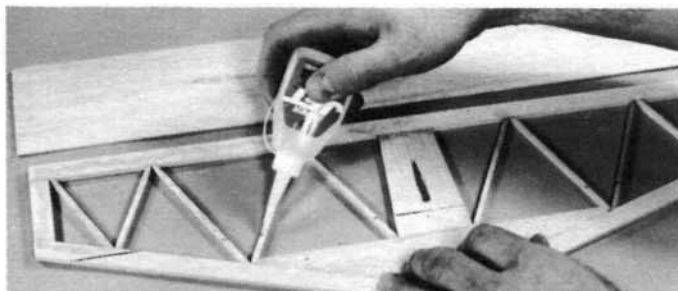

width on stab to show gluing limits.

- Remove sheet and apply CA to T.E., tips and trusses. Turn stab over, position on balsa sheet and press down flat

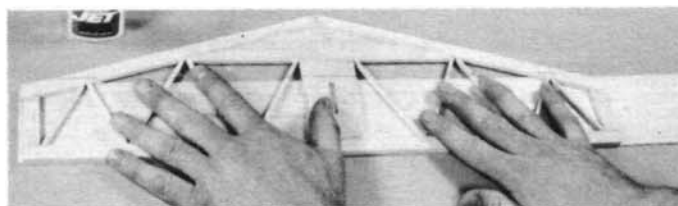

on table.

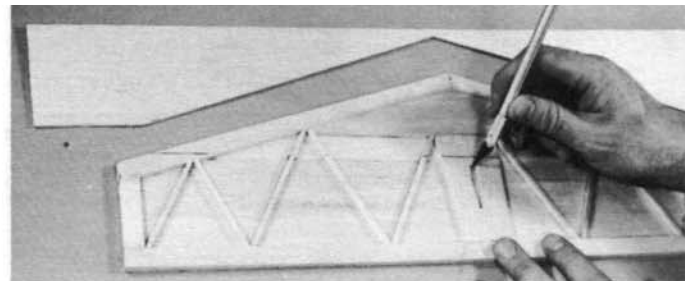

- Center second sheet under stab L.E. and glue in place.
- Cut out center slot in stab platform for fin post.

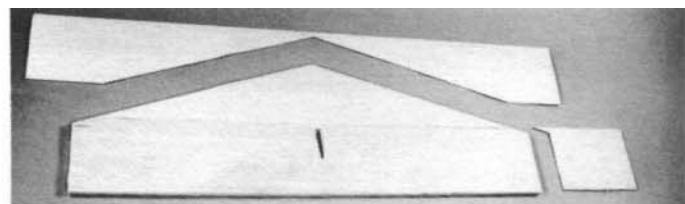

Carefully trim balsa sheet to match stab outline.

- Turn stab upside down and cover other side in same manner.

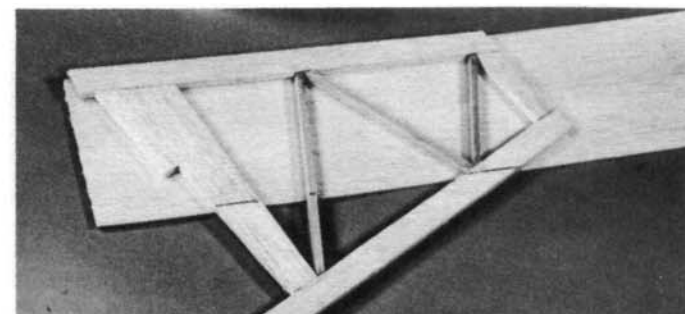

- 6b.  Flush balsa sheet with fin L.E. and glue.

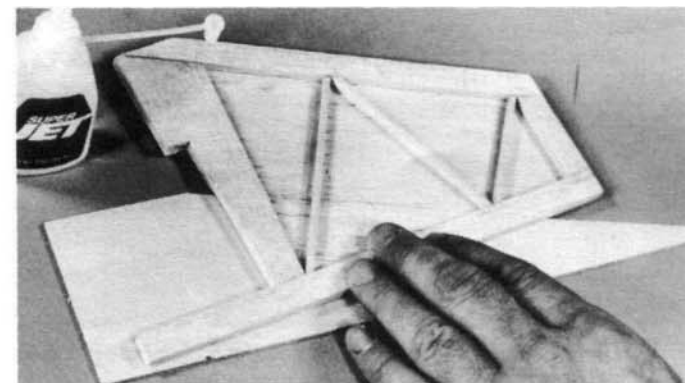

- Use stab scrap to complete fin sheeting as shown.
- Trim sheet to match fin outline.

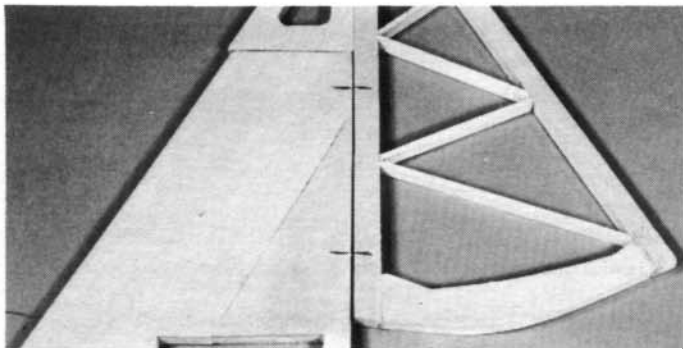

7.  Place fin and rudder over plan and mark hinge locations.

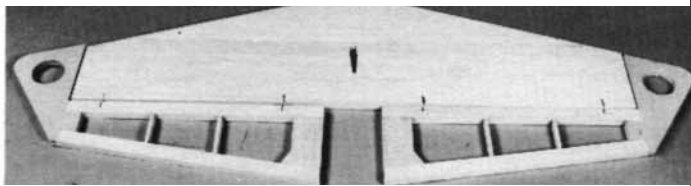

Mark hinge locations for stab and elevator.

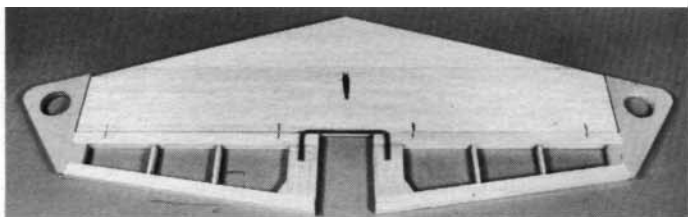

Position elevator halves and joiner over plan, and carefully mark elevator L.E.'s for wire joiner location.

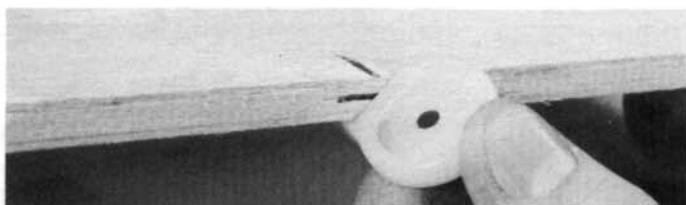

8.  Using CG Center-line marker provided, mark center-lines along edges of parts as shown above. Tilt marker so guide pegs touch the wood, then lightly pass the marker back and forth. Point will scribe center line.

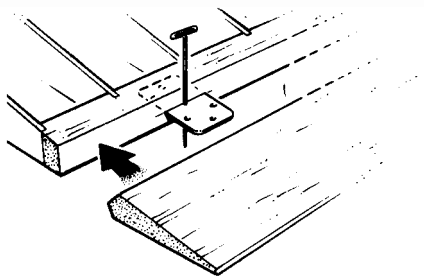

9.  At locations marked in Step 7, make a slit wide enough for the JET Hinge to fit into.

**IMPORTANT!** Although you are installing the hinge now, the hinges are not permanently installed until after the model is covered.

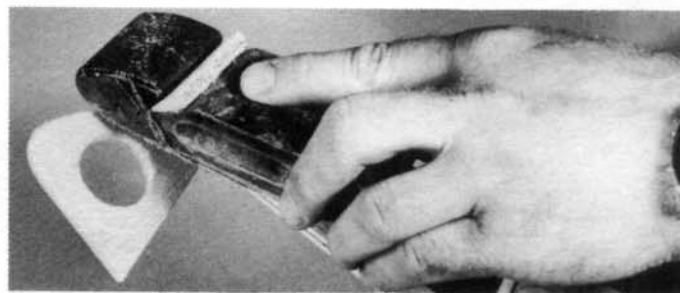

12.  Using no glue, TEMPORARILY attach elevator to stab and fin to rudder with hinges in place. Hold parts together with tape.

First break corners with the sanding block. Then, follow low with stab sanding tool, rounding off all outside edges except bottom of fin and rudder. Blend stab and elevator at tip.

Using a sanding block, flat sand stab, elevator, fin and rudder, smoothing out surfaces.



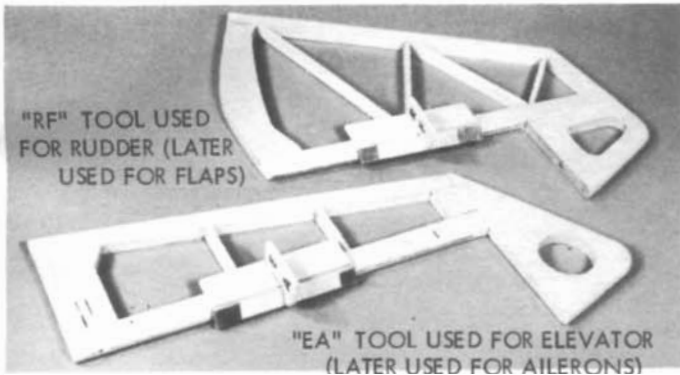

**13.** □ Remove tapes and separate elevator and rudder from stab and fin.

□ Tape T.E. of elevator and rudder to work surface, using appropriate beveling tool, sand L.E. to center-line. Turn parts over and repeat beveling for other side.

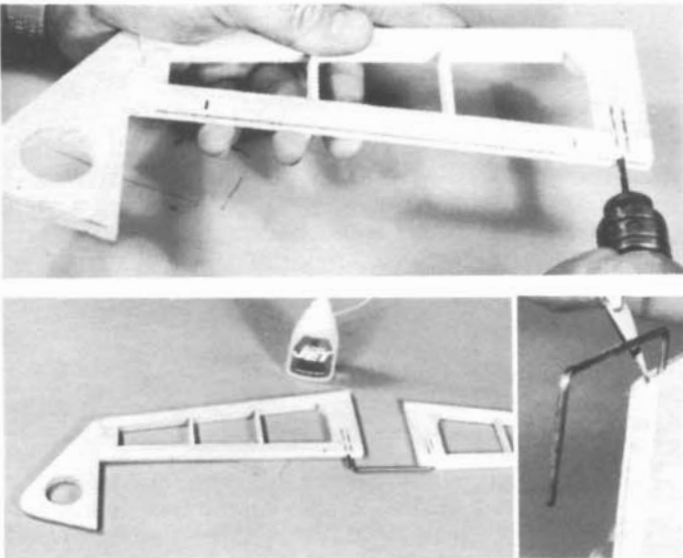

**14.** □ Using no glue, trial fit elevator halves together with wire joiner. Carve a radius for better fit at wire bend. Elevator halves must lie flat on table and L.E.'s must be aligned. Punch a small pin hole through elevator at rear of joiner hole for glue squeeze-out. Glue joiner in place.

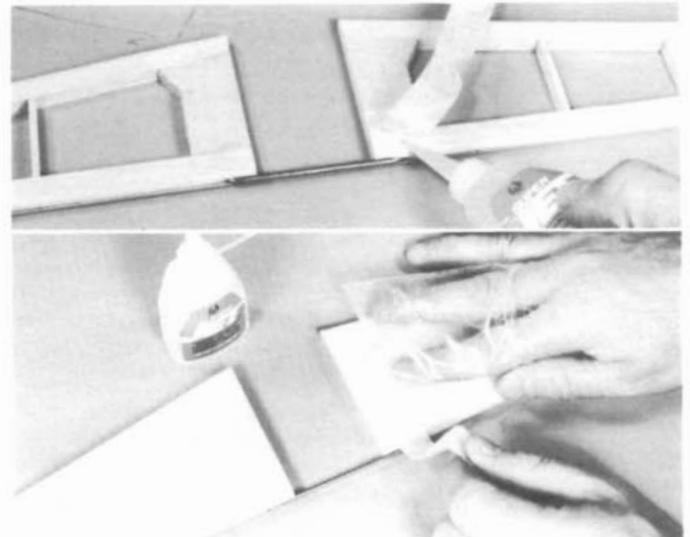

**15.** □ For strength, the elevator joiner areas should be reinforced with nylon fabric as follows.

□ Apply a dab of CA to the elevator and press one end of nylon fabric into it (cover finger with a plastic bag or similar).

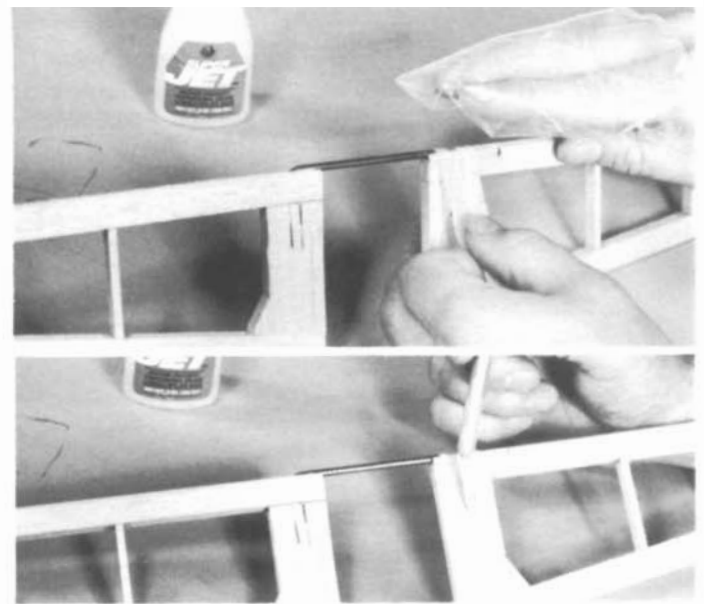

□ Apply a squiggle of glue to elevator and pull nylon fabric down into it. Rub nylon into the glue with your finger.

□ Continue gluing and apply nylon around elevator front and around to other side. Trim nylon Cut.

□ Repeat this procedure and apply nylon on other joiner area.

**This completes the tail assembly construction.**

# Wing Assembly

**PROCEDURE:** The wing panels are assembled bottom side up and then turned over for joining and finishing.

**IMPORTANT!** Although the wing is a symmetrical section, because of internal structure (landing gear and aileron bellcrank mounts), some ribs are not symmetrical (such as Ribs No. 2, 4, 7, & 8). As an aid for proper rib orientation, the tip spar notches for some ribs have only been partially laser cut.

**IMPORTANT,** wing assembly will begin with building a panel over the "RIGHT WING" on the full-size plan, later on when it is turned over, this wing will of course become the left wing. "Right" or "Left" wing refers to the panel being assembled during that particular step **OVER THE PLANS**.

Since the wing is built in two halves, and steps 1 to 17 are repeated in the process, two check boxes are provided with each of these steps. One for the right wing and one for the left.

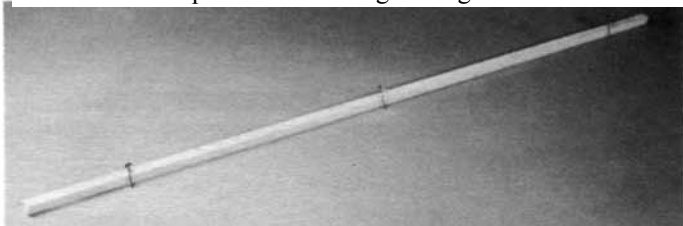

**1.**   Position one main spar in place over **RIGHT WING** (or **LEFT WING**) on plan. Align spar at center of wing on plan. Hold spar in exact position by crosspinning at circled location on plan. **CAUTION:** Do not build two **RIGHT WINGS!**

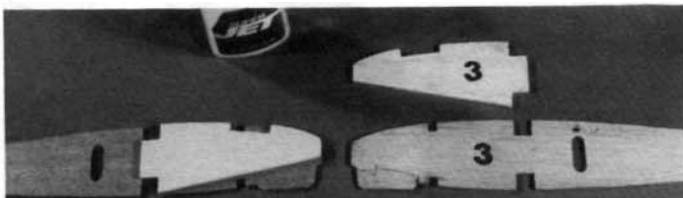

**2a.**   Lay parts out as shown. Glue plywood rib doubler 3 to rib 3 (**IMPORTANT!** Position slot in ply doubler at top edge of rib 3).

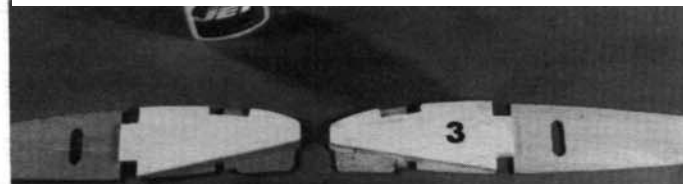

**DOUBLERS MUST FACE EACH OTHER IN WING.**



**2B.**   Lay parts out as shown. Glue plywood rib doubler 5 to rib 5.

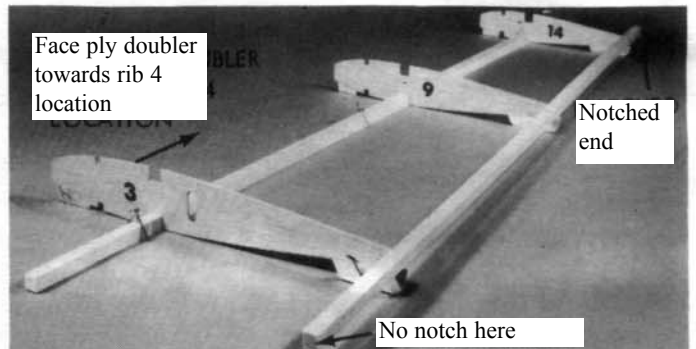
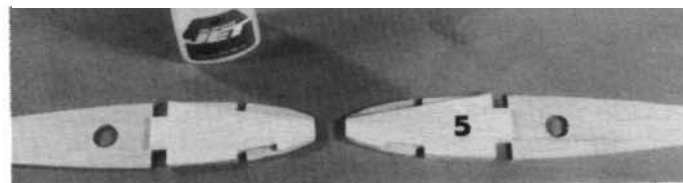

**2c.**   Using no glue, place platform ribs 3, 9, & 14 on spar at their respective places over plan (position rib 3 so ply doubler faces towards rib 4)

Rest notched Trailing Edge (T.E.) on rib platforms (Important: the T.E. has no notch at one end-this unnotched end must be at wing center as shown).

Press T.E. on rib 3 then slip ribs 9 & 14 into their respective notches. Pin T.E. to ribs and rib platforms to building board. Glue ribs to T.E. and spar (avoid gluing T.E. to rib platforms).

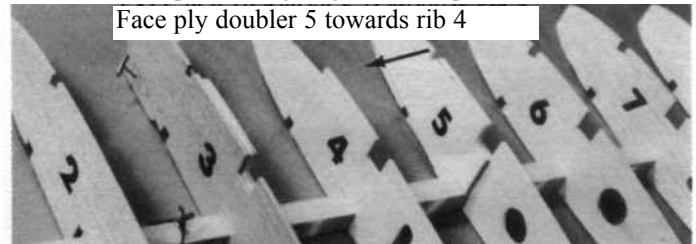

With landing gear slots facing up, set ribs 4 & 5 in position (NOTE: rib 5 ply doubler must be facing rib 4).

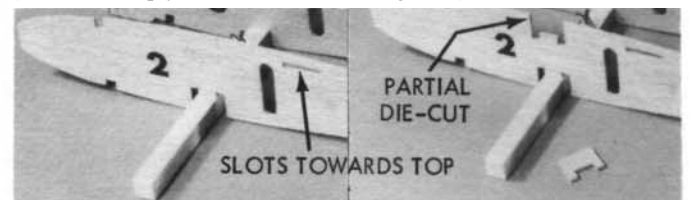

Working one at a time, glue remaining ribs 2 to 8 & 10 to 15 to spar and T.E. (NOTE: slots in rib 2 must be towards upper rib edge, slots in ribs 7 & 8 must face up towards rear of wing as shown). Hold each rib straight up as it dries. **IMPORTANT:** for a warp free straight wing, make sure T.E. is kept straight and not bowed up or down, shim with balsa if required.

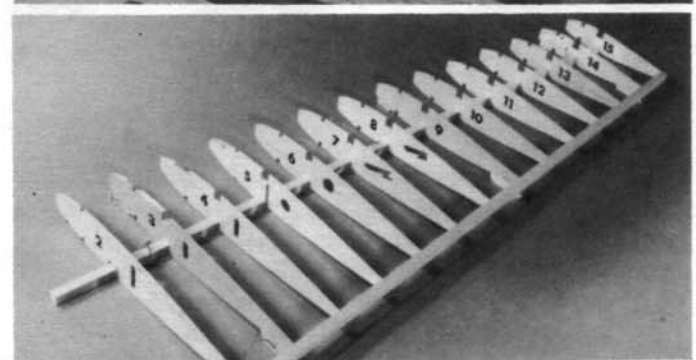

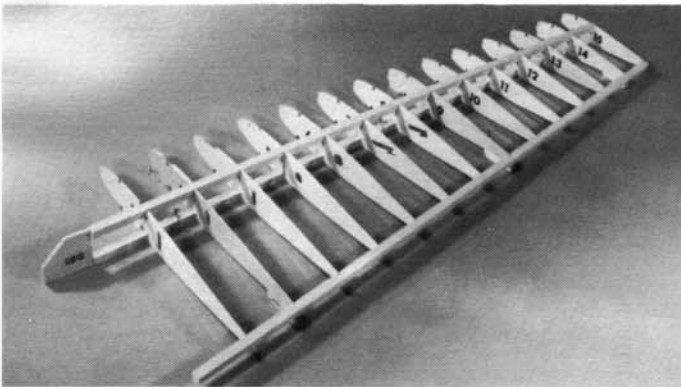

**3.** □□ Position the Set-Back Gauge (SG) touching the bottom spar. Touch end of top spar to gauge, and set spar in rib slots.

□□ True top spar to all ribs.

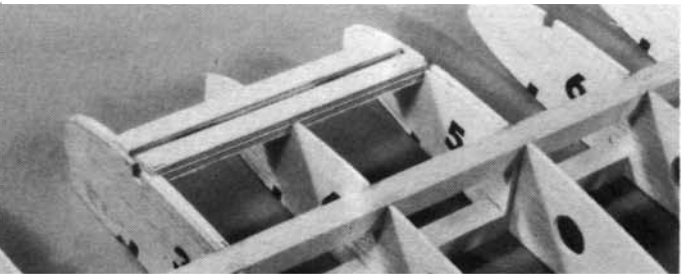

**4.** □□ With slot facing out from wing, glue landing gear block to ribs 3,4,&5.

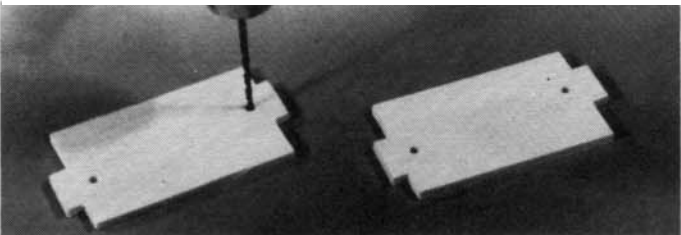

**5a.** □□ Drill four 5/64" dia. holes (1/16" will do) at punch-mark locations through aileron bellcrank mounting plates.



**5b.** □□ Position aileron mounting plate in rib 7&8 slots, this part is designed to fit only one way. Glue plate in place.

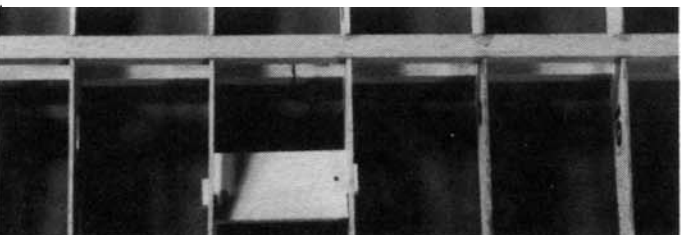

**6a.** □□ Pin wing at outside of ribs 2 & 15 and T.E. and remove pins from interior area of wing.

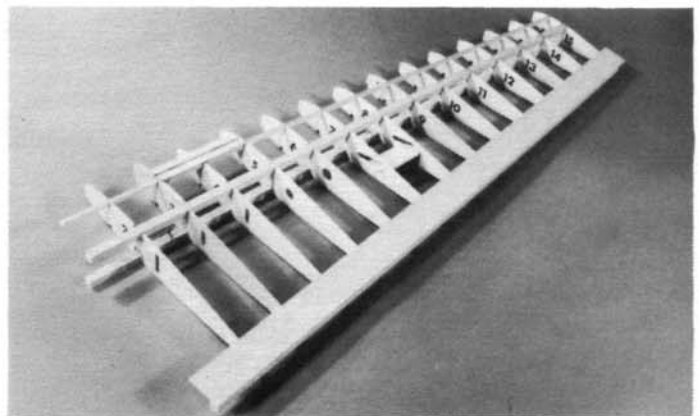

**6b.** □□ Align T.E. sheeting with center end of T.E. and adjust sheet so it is flush along T.E. Glue in place. If sheeting edge is not straight, let excess hang out over T.E. for trim off later.

**6c.** □□ Glue 3/16" Sq. x 36" balsa into forward rib notches. Cut to fit around L.G. mount. Balsa should project out from rib 2 about the same distance as main spar.



**7.** □□ An opening for the L.G. mount must be made in the L.E. sheeting. Begin by aligning 5/65"x3"x36" L.E. sheeting with front edge of spar and flush with spar end.

□□ Project and mark two lines straight back from the ends of the L.G. mount and on to the L.E. sheet.

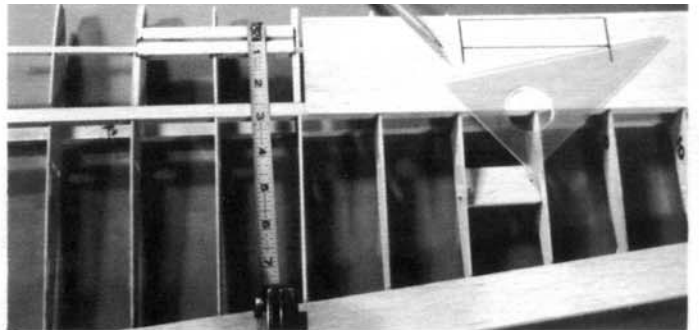

□□ Slide sheeting over to side of L.G. mount. Align sheet with back of spar and measure and mark the front and rear L.g. block locations. Measure L.G. block locations from the back of the spar.

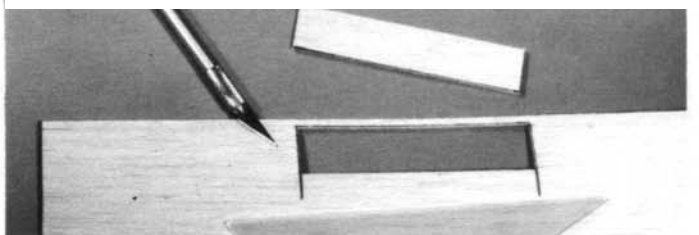

□□ Cut the opening a little undersize at first and try in place. Enlarge opening as required for proper fit.

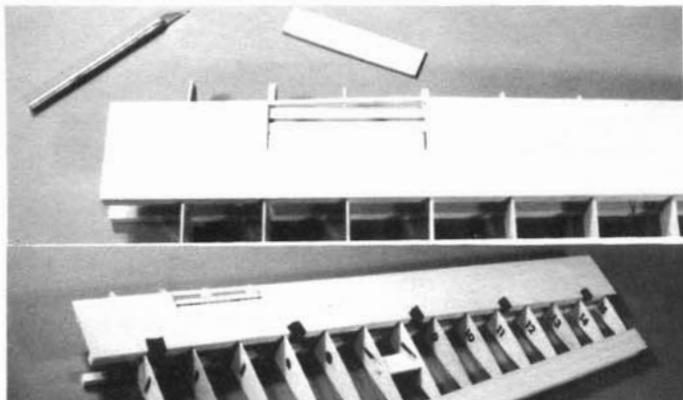

**8.□□** Tape L.E. sheet in place along back edge of main spar. With taped edge acting as a hinge, lift sheeting up and apply glue to tops of all ribs and both spars. A shot of Kicker on the L.E. sheeting will help set things quickly. Carefully close sheeting and gently press it down



on glued structure beneath. (Moistening the sheeting's outside surface can assist in bending it to air foil shape.)



**9.□□** Glue laser-cut wing tip sheeting in place.



**10.□□** Glue laser-cut tapered L.E. sheet in place.



**11.□□** Install Mini-Snaps at both ends of 13-5/8" double threaded wire rod. About 1/16" of threads should protrude through Mini-Snap.



□□ Insert Mini-Snaps and rod into wing through rib holes just behind the spar. Temporarily tape Mini-Snap to aileron mount.

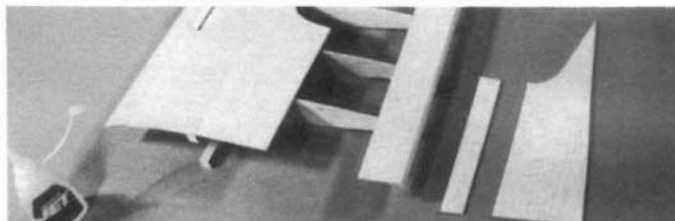

**12.□□** Glue laser-cut center sheeting in place, trimming to fit as required.

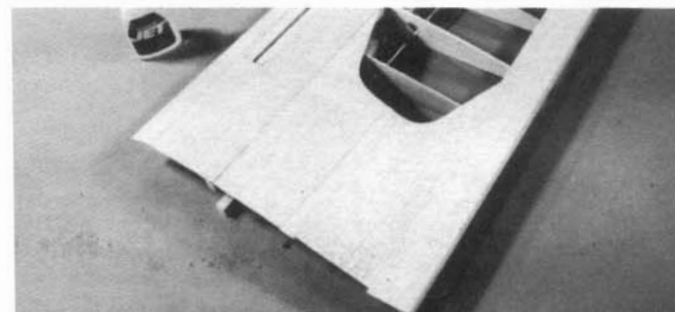

□□ Allow wing structure to dry thoroughly

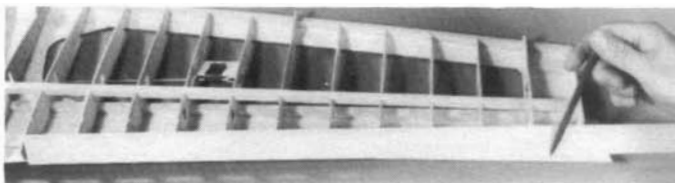

**13.□□** Remove all pins from wing structure and turn wing upside down.

□□ Trim excess T.E. sheeting flush with T.E.

□□ Position a straight edge along front edge of outer ribs and mark a cutting guide line on the overhanging sheeting.



□□ Rough trim sheeting overhang to line, leaving about 1/8" of sheet for final sanding.

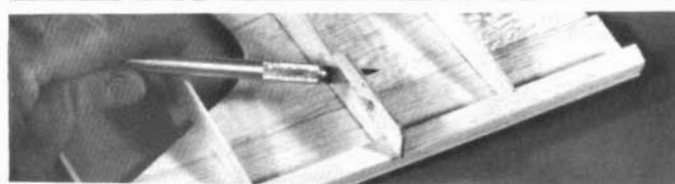

□□ Remove platforms from ribs 3,9,& 14.

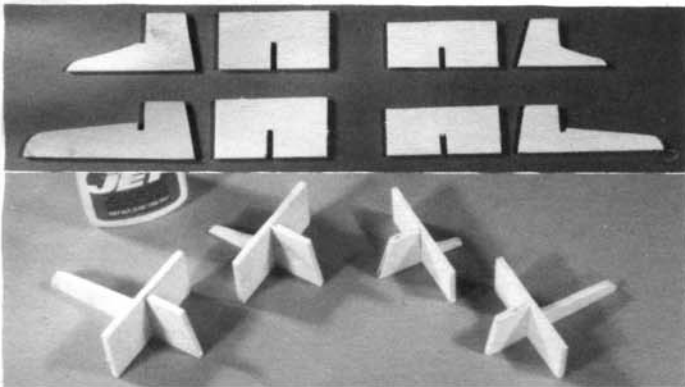

14. □□ Lay out wing supports as shown. glue together.

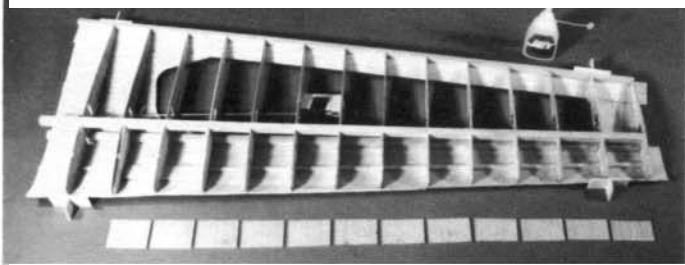

15. □□ Using wing cradles, support wing and pin in position over plan.

16. □□ Lay out laser-cut spar webs as shown. Glue spar webs to front of top and bottom spars.

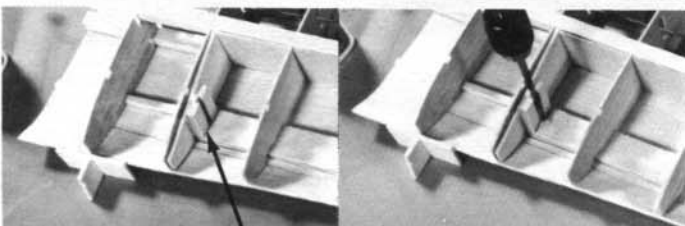
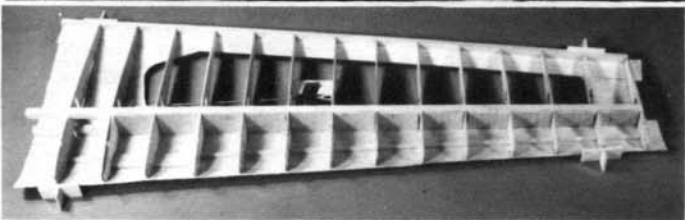

17. □□ Glue one ply torque block to rib doubler 3 and L.G. block as shown—IMPORTANT! Block must be angled back towards spar. Let dry thoroughly.



□□ Drill a 3/16" diameter hole through each L.G. block using torque block slots as a drilling guide.

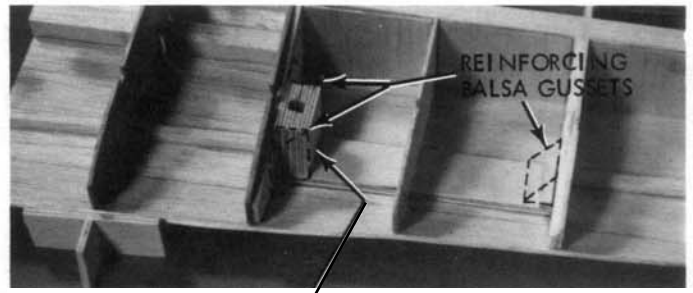

□□ Glue second torque block to first, making sure to align slots and angles.

□□ From 1/2"x1/2" triangular balsa, cut reinforcing gussets to fit as shown. Glue together.

18. □ Repeat steps 1 to 17 over "LEFT WING" on plan.

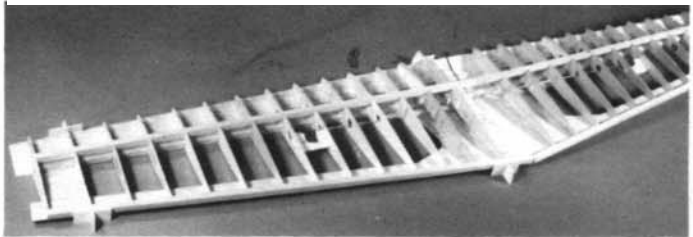

19. □□ With left wing on wing supports, pin in place on plan.

Position RIGHT WING in place next to it. Raise RIGHT WING

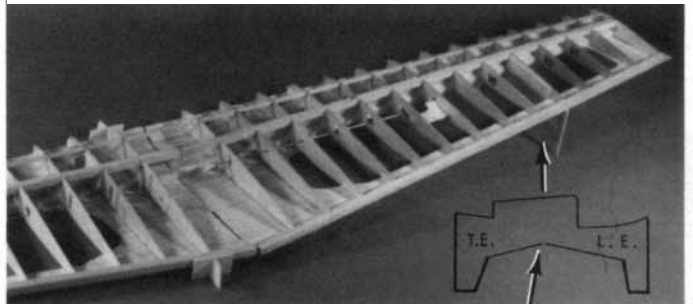

tip and support it at rib No. 11 using laser-cut gauge. Note; gauge is shaped to fit under curved L.E. and angled T.E. sheeting. Hold gauge firmly to the rib by tack-cementing or stationery clamps, clothspins, etc.

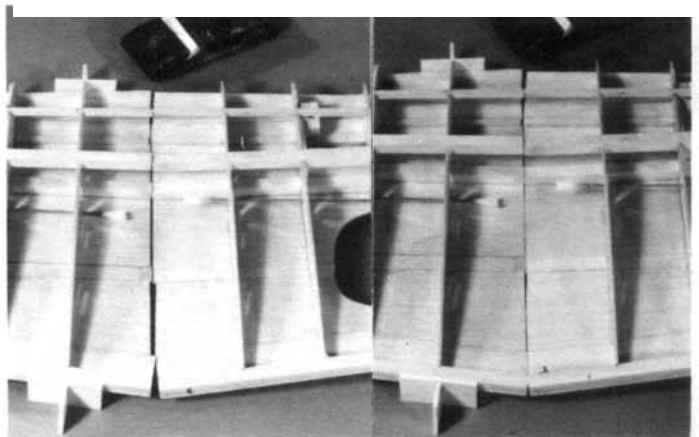

19. □ Study the entire center joint; all end parts of right wing should just touch those of the left ( tiny gaps are all right). If the fit between most parts is a little loose because one part protrudes too much, slightly sand only the protruding part for better fit. When sanding it is better to take off too little than too much.

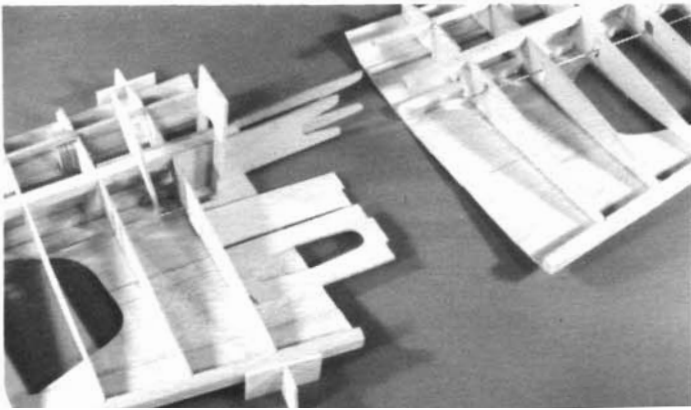

**20a.** □ Pull wing panels slightly apart and slide aileron servo mount into forward slot in rib No. 2.

□ FOR FLAPS ONLY. From 1/8" ply (not furnished) cut a flap servo mount using template on wing plan. Position flap mount in rear rib No. 2 slot.

**20b.** □ Using no glue, temporarily install ply dihedral joiners in left wing carefully insert them into rib notches. Hold joiners with laser-cut clamps.

□ Reposition right wing next to left, engaging joiners and aileron (and flap) mounts in respective slots in Rib 2. Install joiner clamps on right wing and make a final check of center joint for good fit of all parts.

□ Remove clamps and separate right wing.

□ Glue joiners to left wing spars, and immediately reinstall clamps.

□ Reposition right wing and pin to hold in position at center joint. Glue joiners in place and hold with clamps.

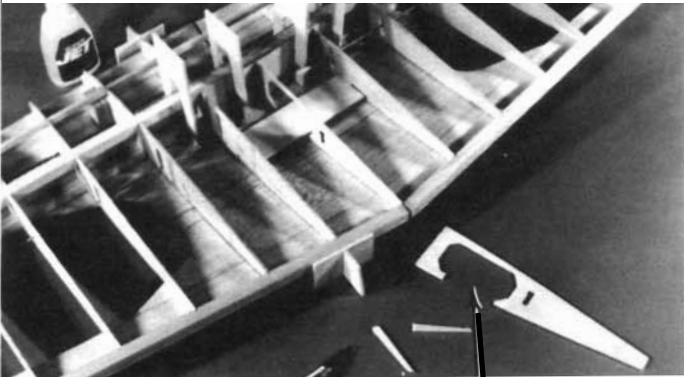

**21.** □ Remove narrow strip at bottom of rib No. 1. Position one half of one front rib No.1 so one side aligns with center line of wing. Adjust rib to align with spar center joints. Glue in place. Glue remaining No.1 rib to first rib, making double thickness rib at center joint.

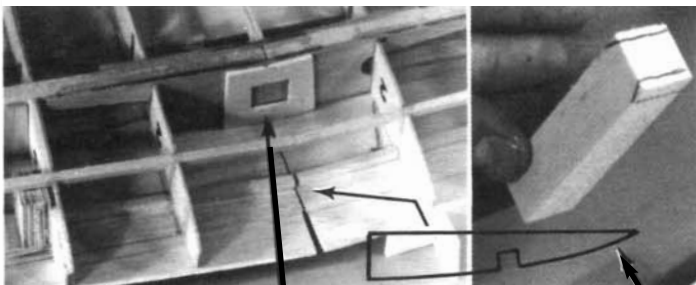

**22a.** □ Glue dowel mounting plate to front dihedral joiner.

□ Glue small filler rib at center joint.

**22b.** □ Mark and sand end of 3/4" Sq.x3-5/8" balsa block for

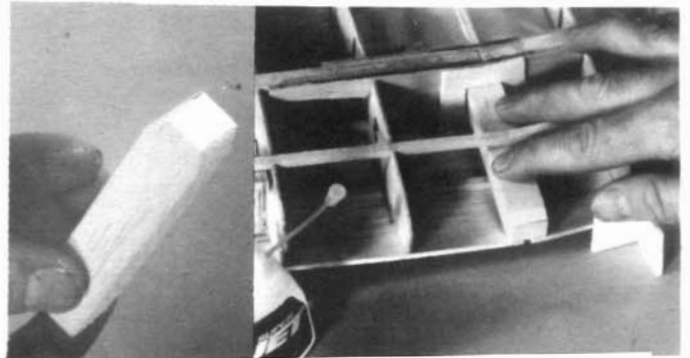

tapered fit with rib front.

**22c.** □ Glue block to mounting plate, and lower ribs.

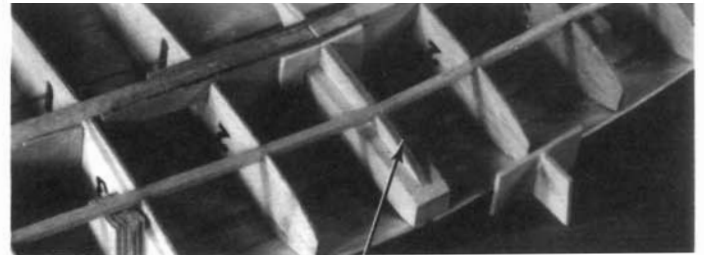

**22d.** □ Position remaining small front rib over block and glue in place.

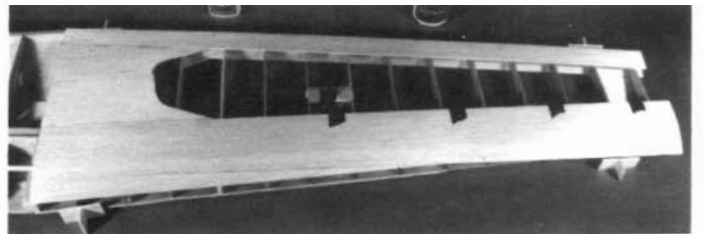

**23a.** □ Position T.E. sheeting on left wing. Trim sheeting to match center joint. Glue in place.

**23b.** □ Following same procedure as step 8, install L.E. sheeting on left wing.

**23c.** □ Install laser-cut tapered L.E. and center sheeting.

**24.** Repeat step 23 and install top sheeting on right wing.



**25.** □ Trim and sand balsa L.E. sheeting flush with rib fronts.



**26.** □ Position Balsa L.E. and hold in place with tape as a hinge. Open and apply CA (Slow dry Thick is good here) to all ribs and sheeting edges. Fold L.E. back into position.

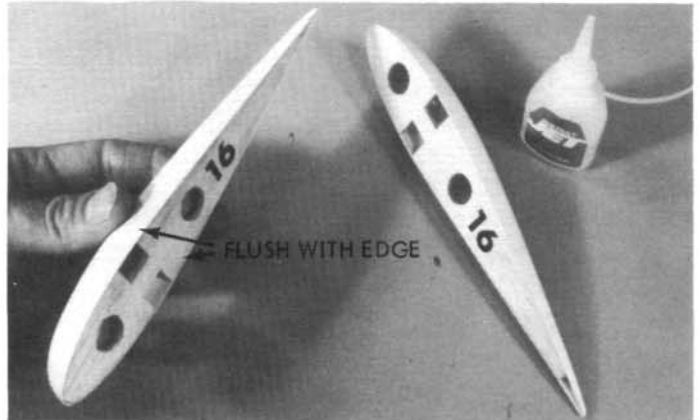
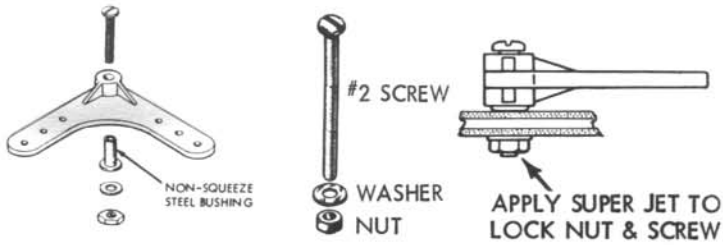

□ Fit 1/8" balsa rib 16 inside plastic tip. Slide rib towards tip front and flush it along all edges. Hold rib in position with a few drops of CA, then apply more along all seams for permanent bond. Repeat for other tip.

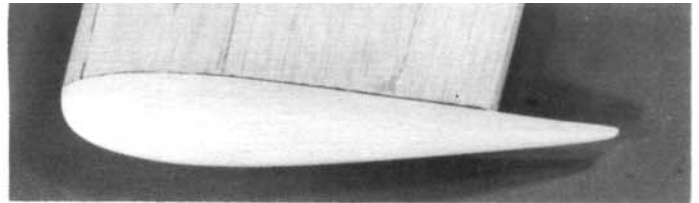

□ Check fit of tips on wing. Using CA, glue tips in place.

- 27.** □ Install aileron bellcranks on bottom side of mounts as shown in sketch and photos (IMPORTANT! for proper aileron function, one bellcrank must be installed in inner drilled hole and the other in outer hole). Refer to plan views.
- Connect Mini-Snaps to outer hole in forward bellcrank arms.



- 28.** □ Cut and bend two 7" long threaded rods to exact size and shape shown in sketch above. Roughen bent end with sandpaper. Insert bend from under bellcrank up into outer hole. Secure rod in bellcrank by pressing a nylon snap-nut over bend end and apply a drop of Super Jet.

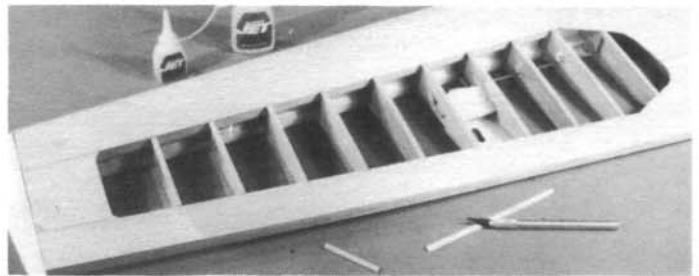
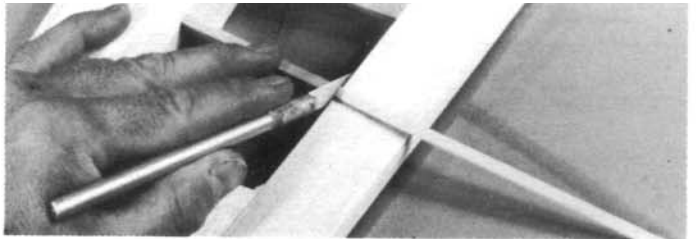

□ From 5/64"x3/16" strips of balsa, cut cap strips to cover the exposed edges of all ribs top and bottom. Glue cap strips so they are centered over each rib.

□ From the three 24" ailerons provided, choose the better two for the ailerons, the remaining one to be cut up for inboard T.E.s (and optional flaps.)

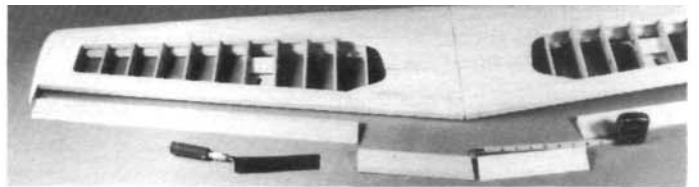

- 31.** □ For "aileron only" wing cut parts over plan as shown above; two 24" long ailerons, and two 7-9/16" T.E. inboard sections.

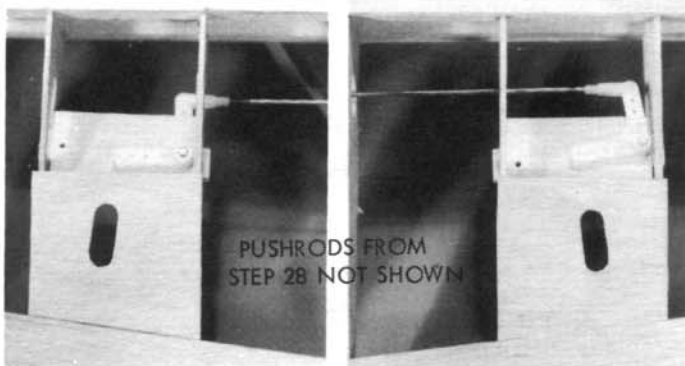
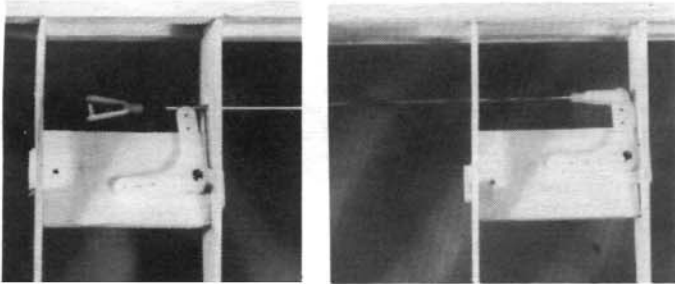

- 29.** □ Position aileron exit sheeting pieces as shown on plan and glue in place (run aileron pushrods through slots.)

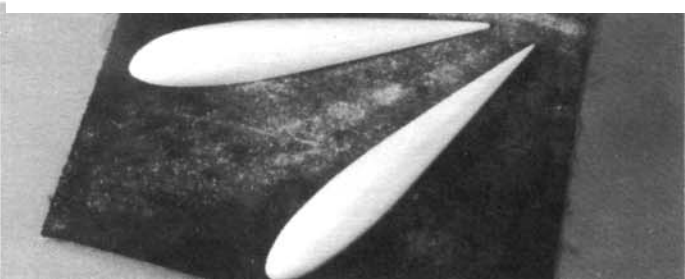

- 30.** □ Position pre-cut opening of wing tips face down on flat sandpaper and wipe lightly a few times. Then, run your finger nail along edges to remove burrs.

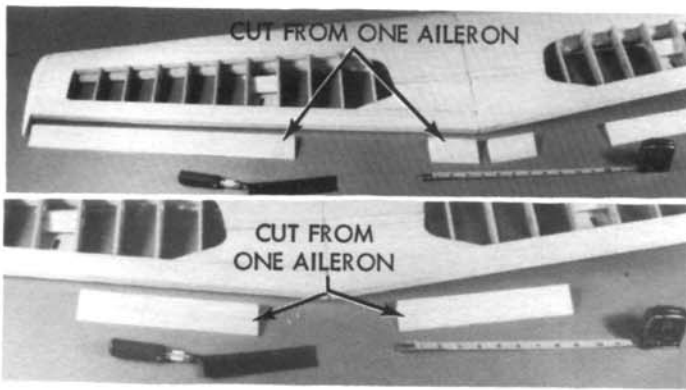

□ For “aileron/flap” wing cut parts as shown: two 19” ailerons, two 9-1/8” flaps, and two 3-1/4” T.E. inboard center sections. Cut over plan for exact size.

**32.** □ Using the center-line marker, make a center line along entire length of ailerons, (flaps), and wing T.E.

**33.** □ FOR AILERON-ONLY WING, continue with this step, for FLAP wing proceed directly to Step 34.



□ Glue inboard T.E. in position as shown above. Proceed to Step 35.

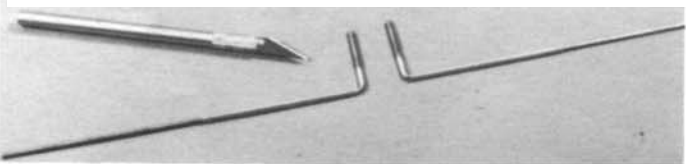

**34.** □ FOR FLAP WING ONLY, cut nylon tubes to 3” length. slide nylon tube onto aileron horn wire. Repeat for other tube and wire.

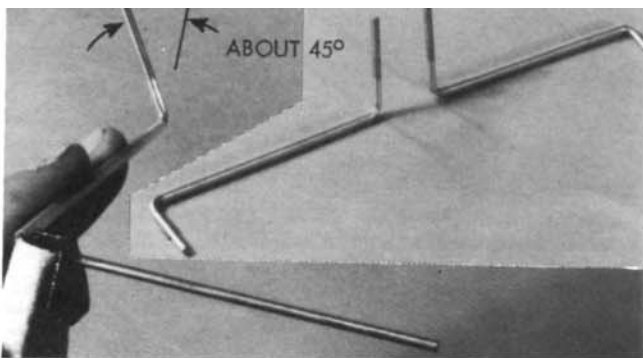

□ Bend one flap horn as shown above. Hold threaded portion of wire at about a 45 degree angle. Firmly grasp UNTHREADED end of wire about 1/2” from end of nylon tube and bend wire horizontally 90 degrees. Check on table, adjust as necessary.

□ Make second flap horn opposite to first by bending UNTHREADED end as shown above.

□ File bent ends to a slightly pointed shape for easier mounting of flaps later.

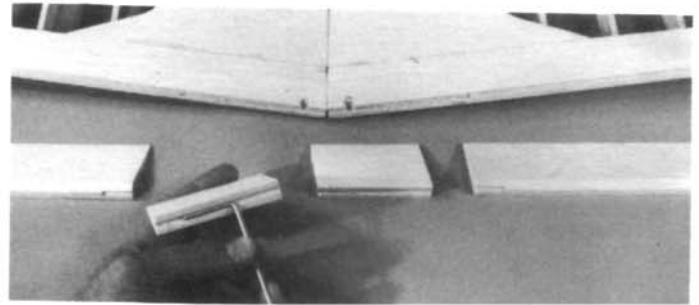

□ Using a sharp tool, make 1/16” deep grooves in T.E. and in inboard sections. Using threaded end of flap wire, file grooves to a rounded shape so half the nylon tubing will lie recessed in both the inboard section and the T.E.



□ Cut two clearance slots about 5/8” from center joint in wing T.E. and from inner ends of T.E. inboard sections.

□ Using no glue at first, temporarily place horns in wing grooves, position both inboard sections and check for horn movement-top to move about 1” total fore and aft.

□ Remove T.E. inboard sections, and carefully glue horn wire tubing and T.E. inboard sections in place (CAUTION: keep glue off wires).



**35.** □ Working over Wing Plan, transfer hinge locations shown on the plan to aileron (and flap) and wing T.E. When fitting aileron, keep it centered to allow clearance at ends.

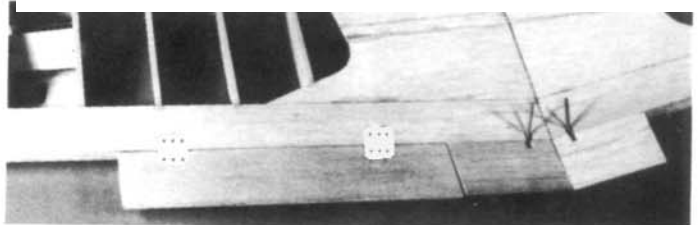

□ Press flap onto end of flap wire to make a mark, with a small nail, make a hole for the wire. Work carefully, keeping the hole centered inside the flap. Repeat for the other flap. Work carefully so that when finished, the threaded ends of horn wires tilt forward evenly with the flaps in position on pointed wires.



**36.** □ Using beveling tool “EA,” bevel front edge of aileron to centerline. Turn aileron over and repeat sanding. Repeat for other aileron.



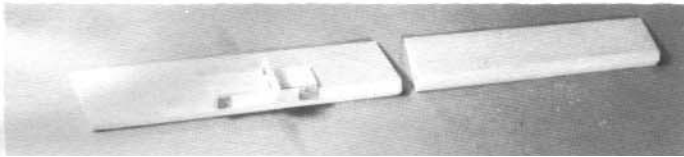

□ For flaps, follow this instruction carefully. Lay flaps side by side and upside down as shown. Using sanding tool “RF”, bevel only the front bottom edge of flaps up to center line (flaps only have to move one direction-down).

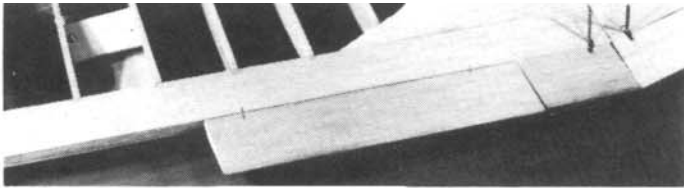

**Flaps “up”**



**Flaps “down”**



**37.** □ Fill gaps, joints, etc. with a filler appropriate for balsa. Smooth out with applicator.

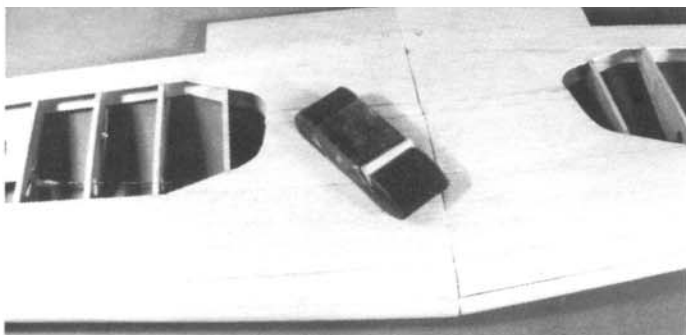

**38.** □ Using 240 grit sandpaper, flat sand entire wing to blend surfaces and remove high spots.

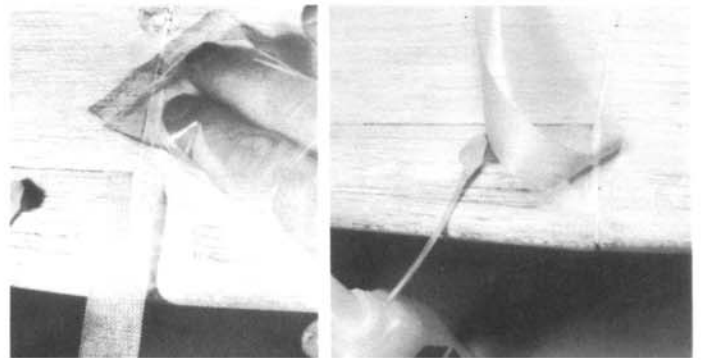

**39.** □ Apply a dab of CA to wing and stick one end of 3/4” nylon fabric to it. Let dry until the nylon is glued solidly to the balsa.

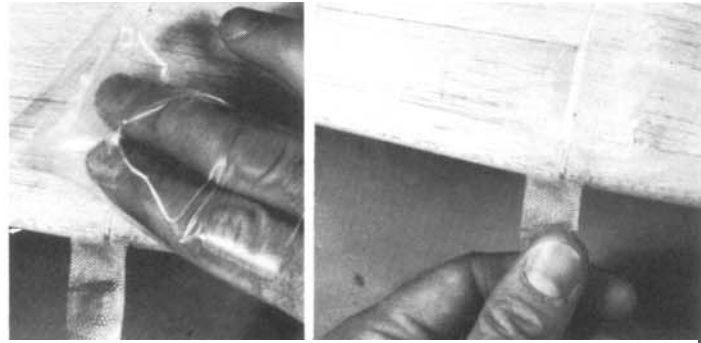

□ Apply a squiggle of CA to wing and pull nylon fabric down into it. Rub nylon into glue with your finger (cover finger with plastic bag or similar).

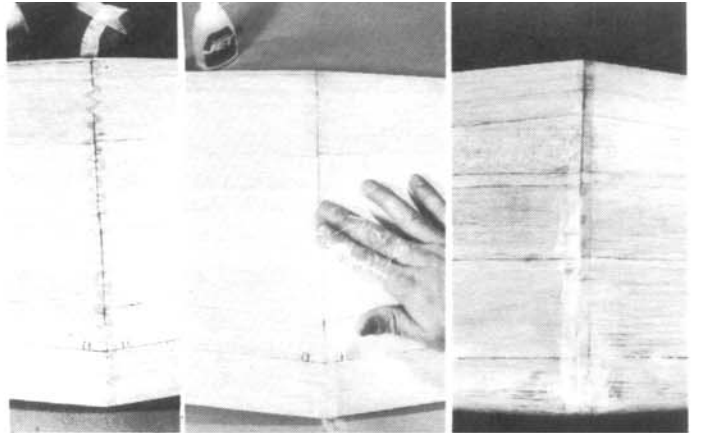

### AILERON SERVO INSTALLATION

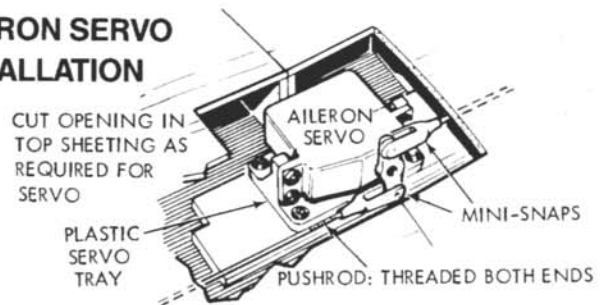

- 1.** □ Refer to plan and cut an opening of similar size in top center sheeting for the aileron servo (and flap servo).
- 2.** □ Install aileron servo (& flap servo) on plastic servo mount furnished with your radio.
  - Remove servo wheel from aileron servo and install large arm furnished with radio, as shown on plan.

□ Temporarily hook-up the aileron servo to the receiver and battery, turn R/C system on and with the transmitter aileron stick and trim tab at neutral, make sure the aileron servo arm is in vertical position (pointing straight up & down relative to wing).

□ Position servo inside wing on ply mount, carefully align bellcrank pushrods with servo arm. Drill holes as required through plastic mount and screw it to ply mount with #2x3/8" sheet metal screws.

□ Mount optional flap servo in same manner behind aileron servo as shown on plan.

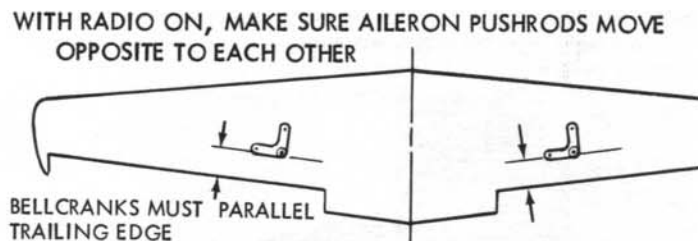

3. □ Connect Mini-Snaps to opposite ends of servo arm. For balanced aileron movement, check that both aileron bellcranks are parallel to the wing T.E., make adjustments as required to Mini-Snap connections at bellcranks.

## WHEEL PANTS & LANDING GEAR

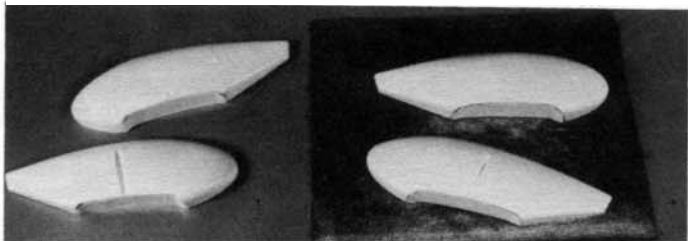

1. □ Rub cut edge of wheel pants over sandpaper and clean burr off edges.

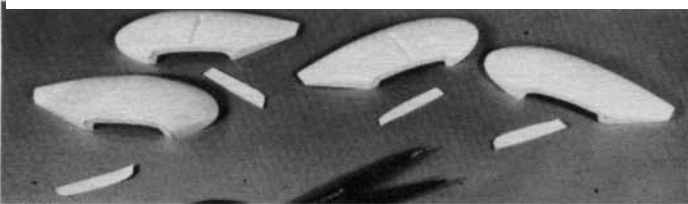

2. □ In the bottom of the four pant halves there is a slightly raised area, this will be removed for the wheel opening. Cut a rough opening in this area of all four pant halves as shown-but stay about 1/8" in from raised line.

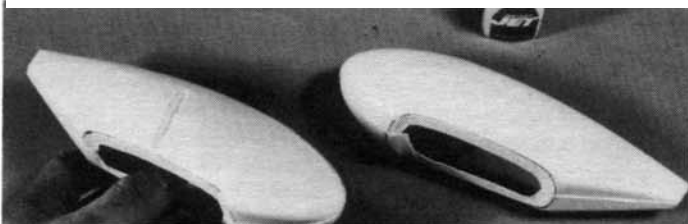

3. □ The pants are designed so one half fits inside the other. Position one pant half (with side slot) inside pant half without slot. Adjust parts for good fit, with about 1/16" to 1/8" overlap. Glue halves together with a few drops of CA around seam.

□ Assemble other pant in same manner.

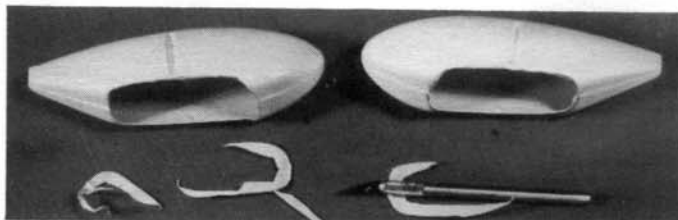

4. □ Enlarge rough wheel opening by lightly tracing the raised outline with a sharp knife. Work slowly, making several passes, making the cut deeper each time.

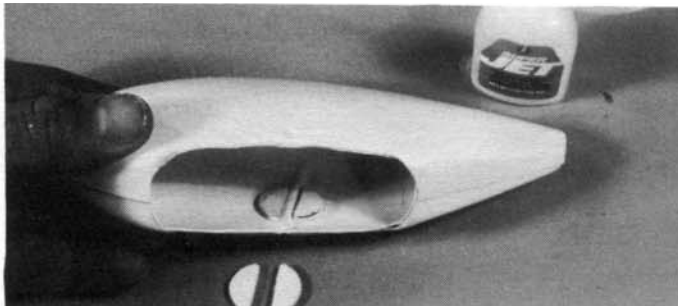

5. □ Glue a pair of half round ply pieces inside pant, on both sides of slot.



6. □ Using a 3/16" dia. drill, open hole on side of pant (do not drill slotted side).

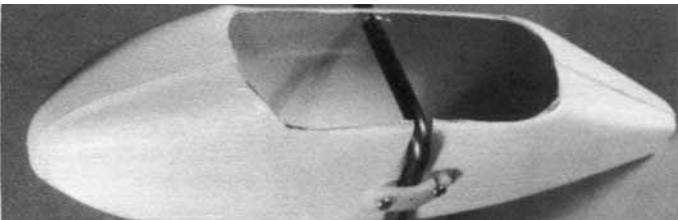

7. □ Using L.G. axle (longer end) into pant. Axle should protrude out pant. Position nylon hold-down over wire at pant side as shown.



Mark, drill, and mount with a #2x3/8" sheet metal screw. At side slotted end, use #2 shoulder screw. If L.G. wire fits loose under hold-down, remove L.G. and glue scrap plastic shim in slot. To remove pant, simply snap hold-down off shoulder screw and rotate it away from L.G. wire.

□ Reglue all pant joints using CA. glue.

This completes the wheel pants. They can be used as is and simply apply decals to them later. Or, if desired, the seams can be filled, sanded smooth and the pants painted.

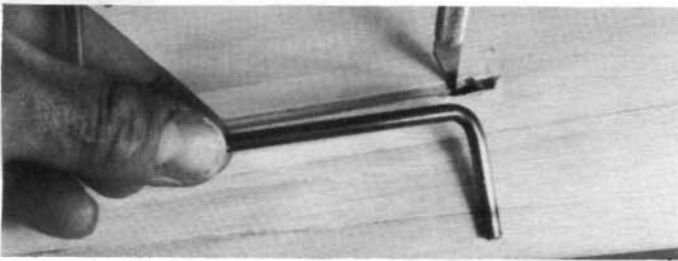

8.  Install the main landing gear in wing. Corner of drilled hole in wing may need to be carved to fit bend in wire.



THIS COMPLETES THE WING ASSEMBLY

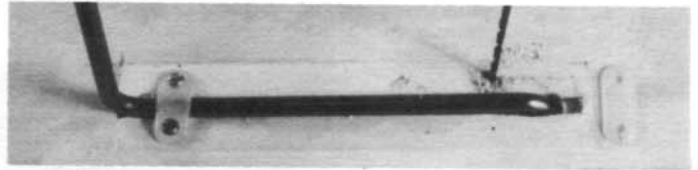

- Position nylon landing gear straps, then mark, drill, and mount with #2 x 3/8" sheet metal screws.

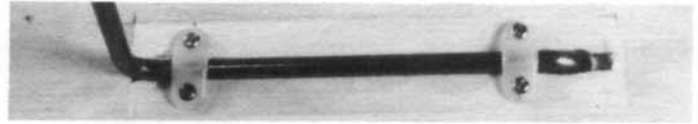

## PLEASE NOTE!

The following information about balancing your model airplane should be considered at all stages of construction. However this diagram should also be used in conjunction with the section noted as "Balancing" on page 32.

# IMPORTANT

**TAKE THE TIME TO PROPERLY BALANCE YOUR MODEL AS SHOWN HERE!  
THIS INFORMATION APPLIES TO ALL AIRPLANES**

Don't be afraid to add whatever weight is necessary to balance your plane according to your needs.



Use the most forward balance point **recommended** for the first flights of any new model, and **for flight training**. Balanced here the model will be "easier" to fly.

Use the most rearward balance point for those experienced in sport and aerobatic flying. The model will be more responsive to elevator control. As balance is moved rearward, more pilot skill will be required.

**WARNING!** If you try to fly a plane with the balance point further behind the rear of the recommended range, you run the risk of having an unstable aircraft and there will be a stronger likelihood of crashing.

## FUSELAGE ASSEMBLY

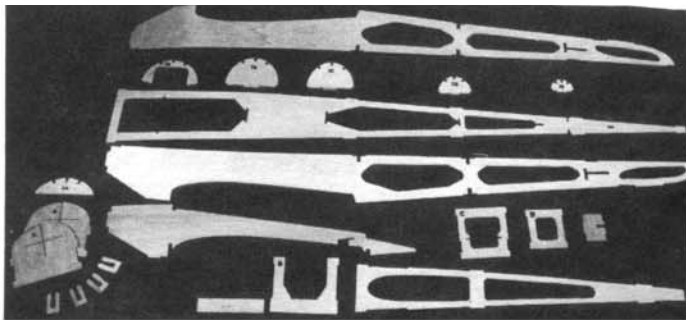

1.  Carefully remove all fuselage (fuse) parts from laser-cut sheets. Lightly sand any rough edges.

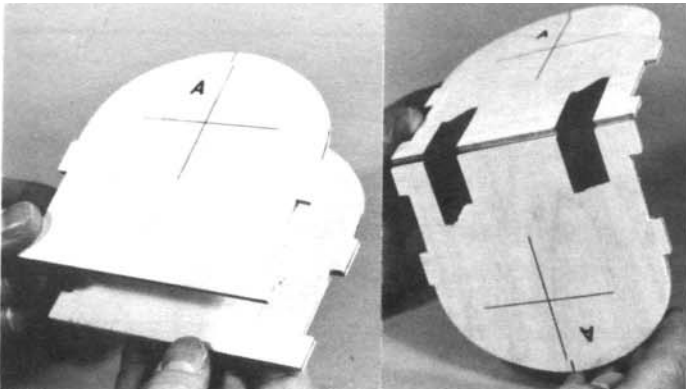

2.  With side stamped "A" facing out, position two 1/8" ply formers "A" (firewall) together, matching all edges. To hold them in alignment, tape them securely together along one edge as shown at right. Have four ply clamps ready for next operation.

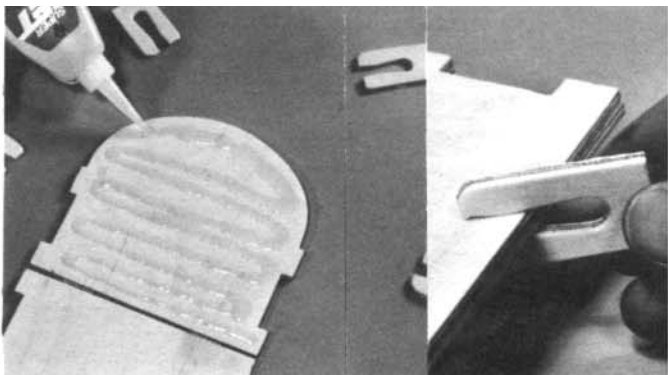

3.  Open firewalls and apply a liberal amount of glue to one part as shown on left.

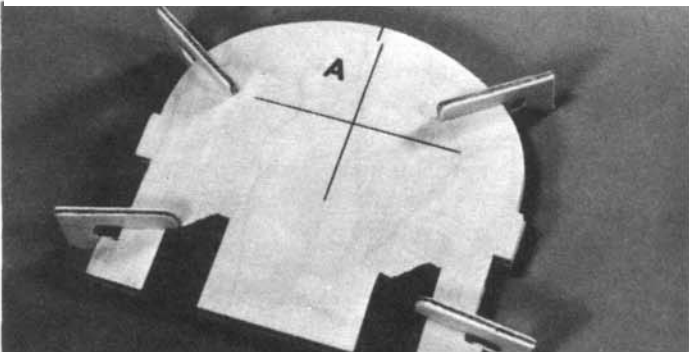

- Keep edges aligned as you close firewalls and tape opposite edges together, squeeze firewalls together using laser-cut clamps. When dry, remove clamps and tapes; set clamps aside for use later.

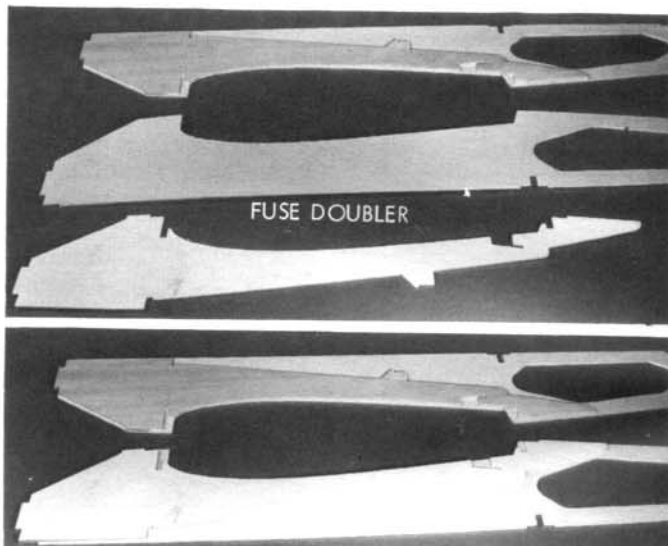

4.  Be sure sides are laid down left and right as shown.  
 Temporarily position fuse doublers on fuse side, checking fit and placement before gluing.  
 Glue fuse doublers in place.

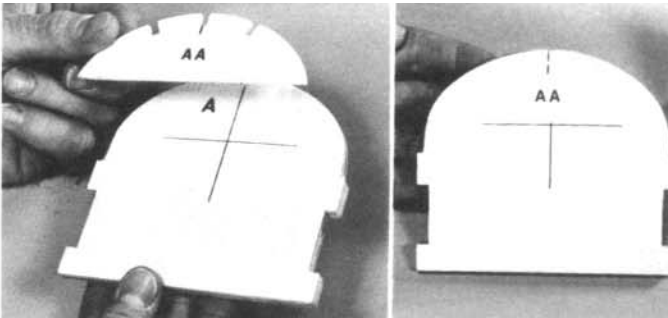

5.  Position former doubler "AA" on firewall so that mark at top of firewall is centered in notch in "AA" and match curved edges of parts.

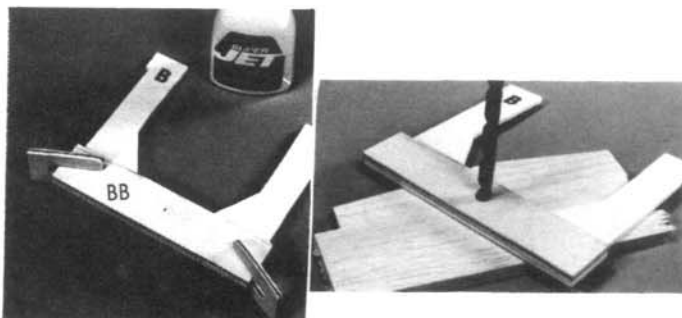

6.  Glue ply former doubler "BB" to bottom of former "B". Hold until dry with firewall clamps.

- From 1/8"x1/2" balsa, cut and glue strips to match formers as shown. Apply strips as shown below.

- At center-punch mark drill a 1/4" hole through former.

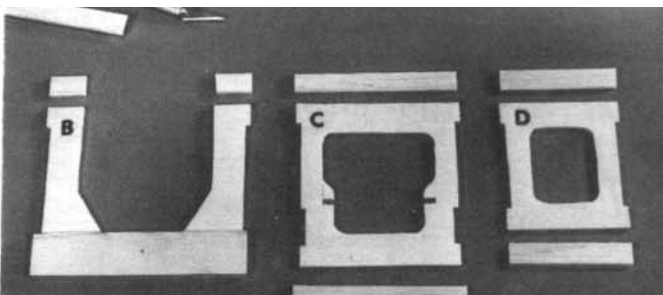

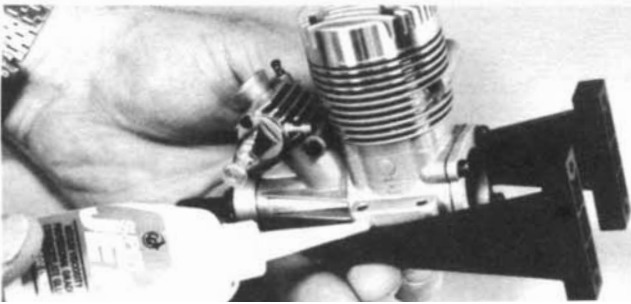
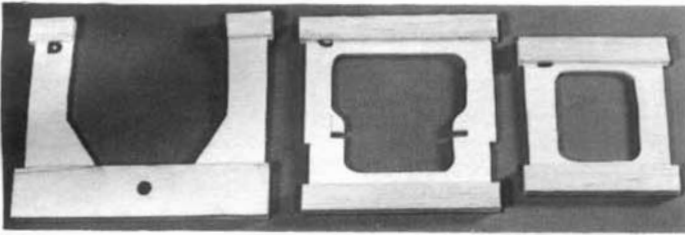

7. □ Tack-cement the engine between plastic engine bearers, holding it vertical and parallel to mounts.

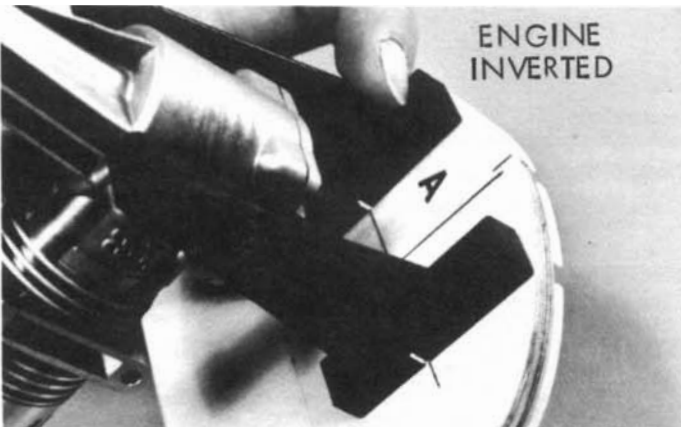

□ Position engine/mounts on firewall for side mounted or inverted installation. Center-alignment marks are molded into engine mount bases; align these marks directly below the engine mounting flanges with the corresponding laser-marked line on firewall. Then measure and position mounts so they are equally spaced from second laser-marked line

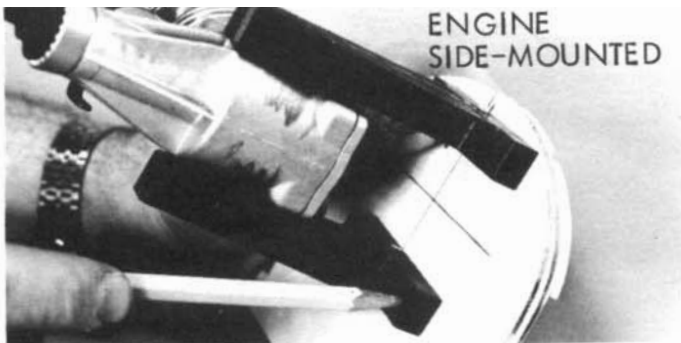

□ Mark straight down through holes in mounts.



8. □ Drill four 5/32" holes at marked locations.

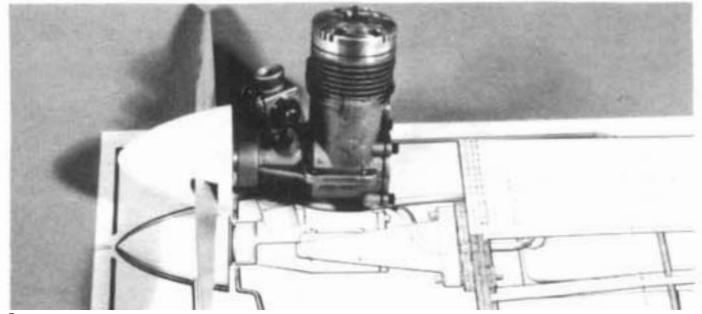

9. □ Mount propeller and spinner on your engine. Position engine over fuse top view on plan and compare it to the installation shown. Back of spinner, should protrude about 1/8" beyond the cowl front as shown on the plan. Hold engine in this location. For long 4-cycle engines, check for at least 1/8" clearance between engine rear and firewall; to obtain this clearance the engine may have to be shifted forward as required. Measure the distance from the engine rear to the firewall. Write this measurement down it will be used later for engine mounting.



10. □ Position one engine mount, butting its rear flange against the firewall location shown on the plan. Observe how the front engine mounting holes relate to the engine mount. If there is at least 1/4" of mount forward of this hole location, the spacer plate shown on the plan is not needed and you should proceed directly to step 11. If there is doubt that the mounts do not project far enough for adequate drilling and engine mounting, the spacer must be installed by completing the steps below. (Note for 4-cycle engines, make sure the spacer does not obstruct the carburetor, cut out spacer center if required for clearance).

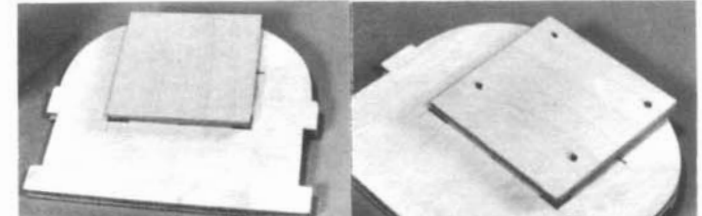
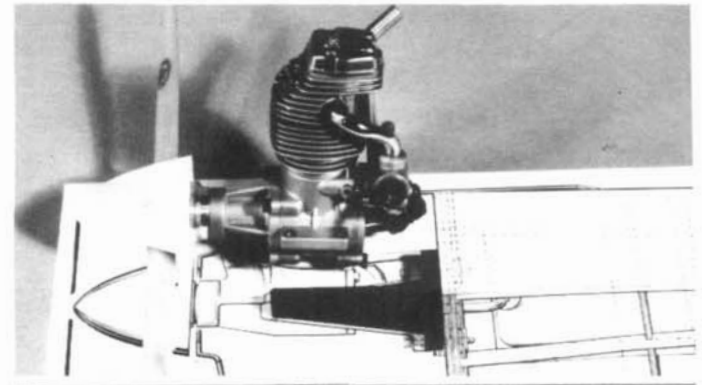

□ Position 1/4"x2-1/8" ply spacer on firewall so that it lies equally spaced over holes (trace spacer shape on firewall, to check position). Glue spacer in place.



□ Turn firewall over, at hole locations, drill 5/32" holes through 1/4" spacer plate.

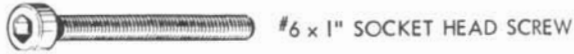
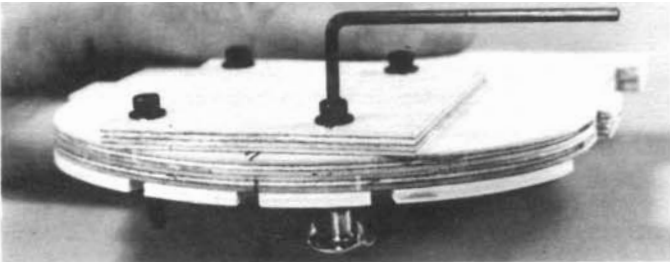

#6 x 1" SOCKET HEAD SCREW

**11.** □ Permanently install four blindnuts in back of firewall using socket head screws and washers to pull blindnuts up into the screw holes as shown (firewall with spacer plate shown for clarity). Remove screws after seating blindnuts. Glue blindnut flanges to firewall.

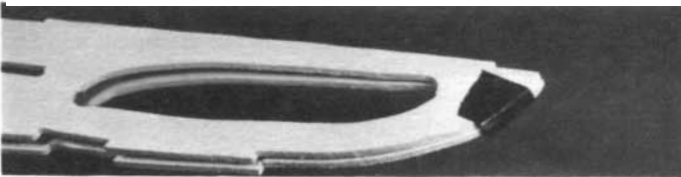

**12a.** □ Place fuse sides one on the other, tape rear together around the back end. Spread fuse fronts apart, and plug former "B"

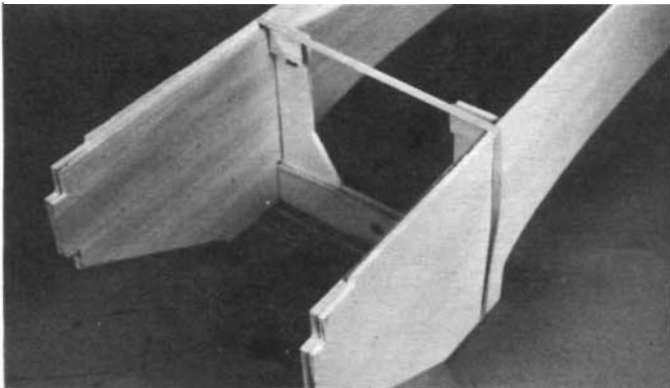

into holes in body sides (doubler "BB" must face forward). Hold parts together with a rubber band.

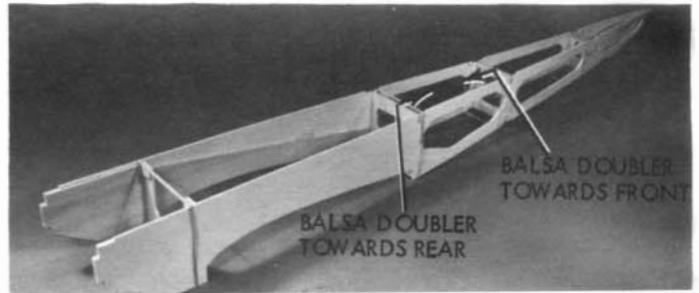

**12b.** □ Hold fuse tail ends up, carefully spread fuse rear open, and plug former "E" in place, hold with a rubber band. Working towards front, install formers "C" and "D" (balsa doublers facing in towards each other) in same manner, using rubber bands to hold parts.

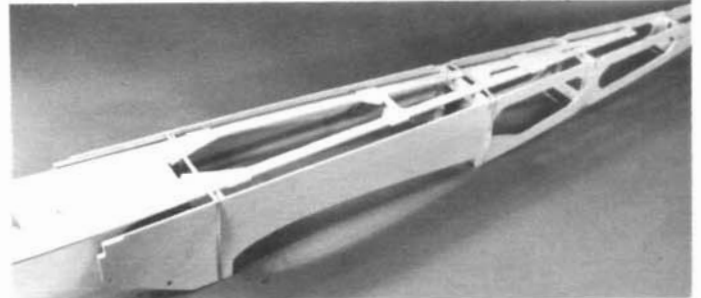

**12c.** □ With laser-cut separation at tail end facing down, insert top sheet under rubber bands at former "B", and work it towards tail, slipping it under bands as you go.

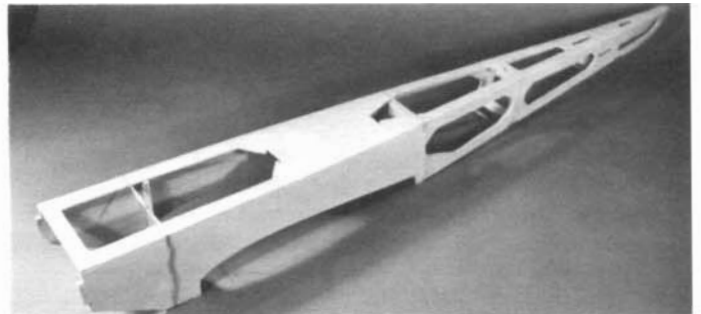

**12e.** □ Lock tabs at sides and ends of top sheet into corresponding notches in fuse sides. Hold parts with tape.

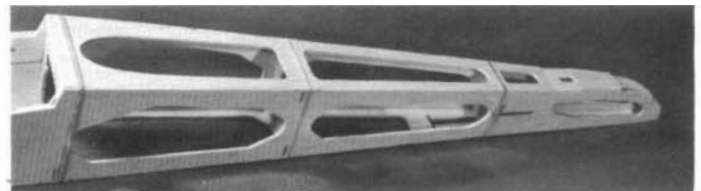

**12f.** □ Position bottom sheet in same manner, sliding it towards rear.

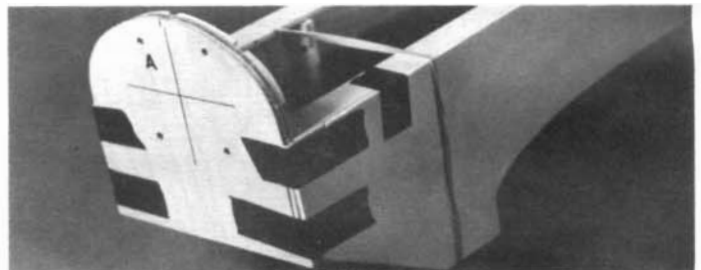

**13.** □ Install firewall and pull fuse fronts together with tape as shown.

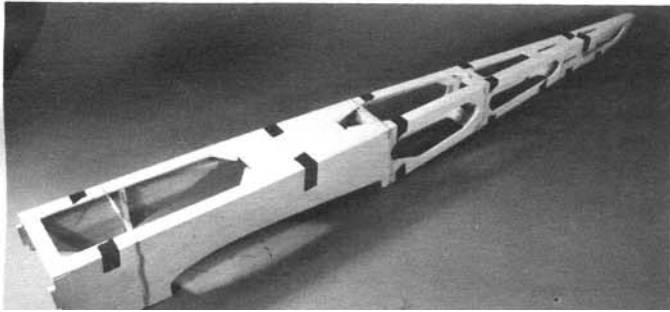

**14.** □ Place fuse over TOP VIEW on plan sheet. Viewing from above, carefully align the fuse to match plan outline. If an area of the fuse is off, adjust that position in the direction required. Tape parts to hold in position.

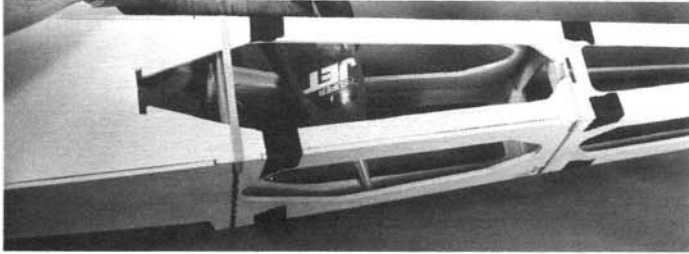

**15.** □ When satisfied with alignment, permanently glue sides, formers and sheet parts in place. Apply a bead of CA along all joints inside and outside, or from both sides.

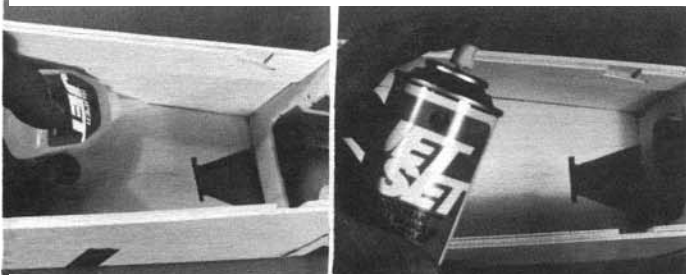

In the case of formers-it will penetrate the joint and leave a slight reinforcing fillet.

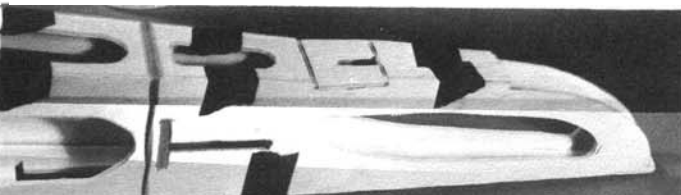

□ At tail end, glue bottom sheet to conform to slight bend in fuse sides.

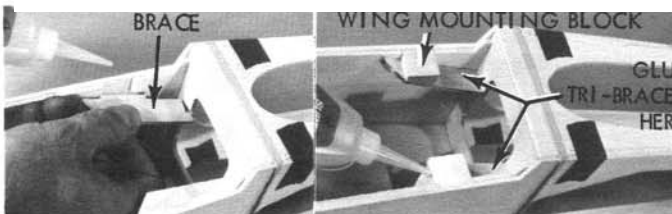

**16.** □ Plug 1/8" laser-cut braces into slotted locations in fuse doublers and glue securely in place.

□ Position and glue wing mounting blocks. reglue these joints thoroughly, the wing attaches here-it must be strong.

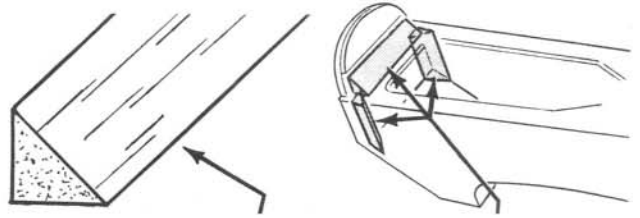
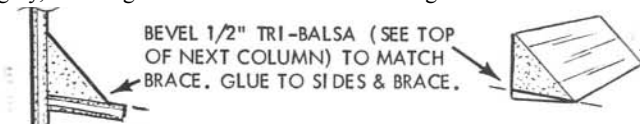

□ From 1/2"x1/2" triangular balsa, cut reinforcing gussets to fit behind firewall. Glue in place.

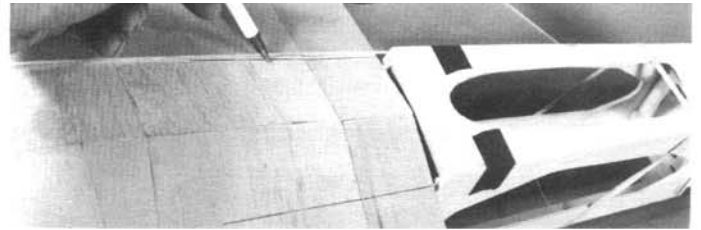

**17.** □ Set wing in place on fuse, then check and adjust until wing tips are equidistance from rear end.

□ Project two lines straight forward from fuse sides on wing bottom.



□ Position a 1/8" ply bolt plate about 1/8" away from line and so that laser-marked line is aligned with T.E. joint as shown. Glue in place. Repeat for second bolt plate.

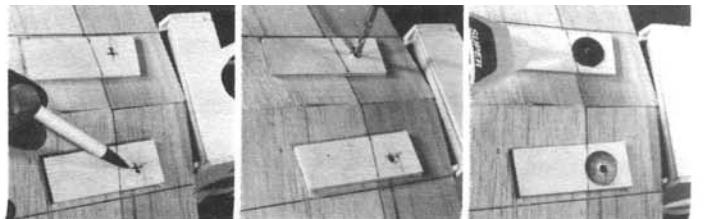

□ Measuring carefully 1-7/16" from wing T.E. and 9/16" in from fuse sides, drill two holes 5/32" dia. down through wing and bolt mounting blocks.

□ Glue two large washers at hole locations.

□ Remove wing from fuse. Install blindnuts in bottom of mounting blocks, pulling them up in place using screws and washers.

□ Install wing using bolts. Check alignment of wing and fuse at front. At hole in former "B", drill a 1/4" dia. hole about 3" deep into wing (try to hold drill square and level into wing).

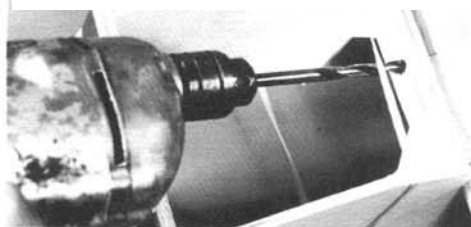

□ Cut 1/4"x4-1/2" dowel to 3" length. Remove wing and glue this dowel securely into wing, leaving about 1/4" protruding.

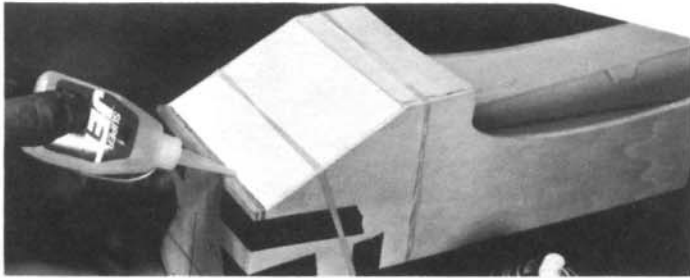

**18.** □ With laser-cut separation facing out, bend and position front bottom sheeting. Glue in place.

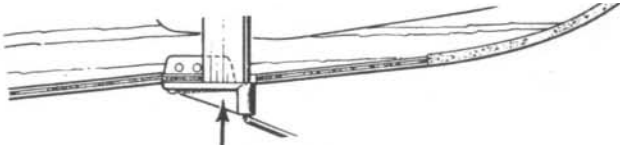

**19.** □ Trial fit the tail wheel bracket at laser-cut separation in bottom sheet. Using a knife or small saw, make a slot for bracket flange as required for correct fit. DO NOT GLUE bracket in place at this time!

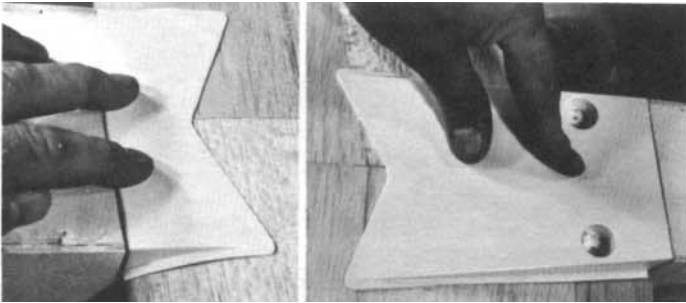

**20a.** □ Cut wing fairings from vac-formed sheets and try fitting them at L.E. and T.E. Cut out bottom of fairing holes and trim hole walls to match washers. Position fairings for best fit with fuse and glue to wing.

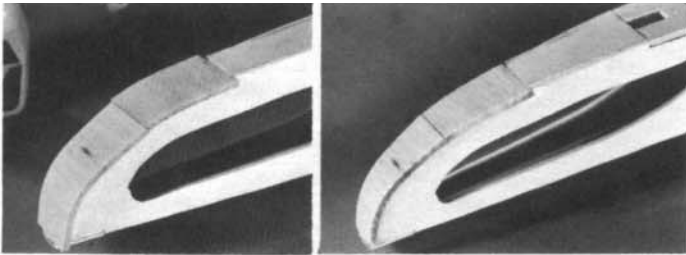

**20b.** □ From scrap 1/8" balsa, glue and trim lower tail end sheeting.



**21.** □ Install top formers "TA", "TB", "TC", "TD" and "TE" in their respective slots in top fuse top (IMPORTANT: tilt formers TB and TC using gauge "TBTC" as shown below).

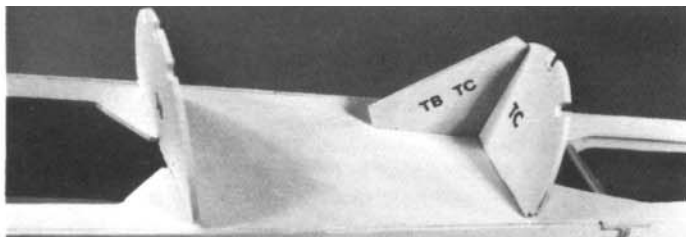

**22.** □ A 1/8" square balsa strip must be glued to the fuselage top to serve as a gluing brace for the top sheeting. Since the front sheeting is thicker than the rear, the front strips are spaced differently than the rear as described below.

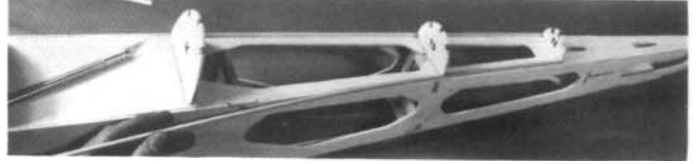

□ From 1/8" square balsa strip cut two pieces to fit from bottom notch in former "TC" to "TE". Keeping strips about 1/16" in from and parallel to fuse edge, glue to top.

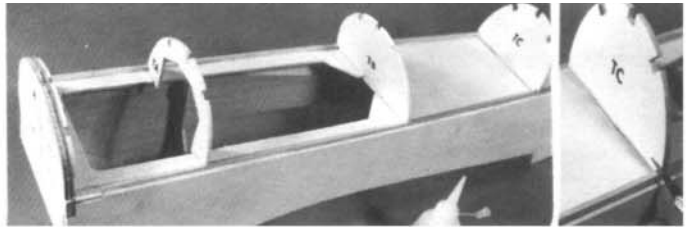

□ Install remaining 1/8" balsa strip in bottom notches in former "TC" forward to firewall-position this strip 1/8" in from fuse side.

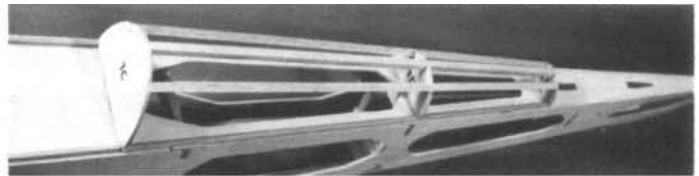

**23.** □ From 1/4" square balsa cut and glue three top sheeting supports to fit notches in formers "TC", "TD", and "TE".

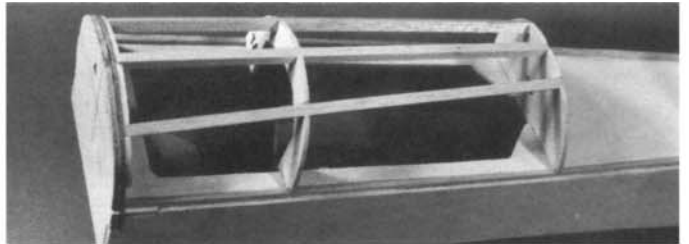

□ Cut three more supports and glue to notches in forward formers "TB", "TA" and firewall.



**24.** □ The three rear sheeting pieces are oversize wedge shapes and are designed to be shifted back and forth for best fit.

□ Begin sheeting installation with one side. Slide sheet in position so lower edge butts against fuse side and upper edge fits about centered on 1/4" balsa support. When satisfied with fit, glue sheet in place (slight dampening of outer balsa surface will help curve it to fit fuse shape).



□ Install opposite side sheet in same manner. Trim sheets flush with front of former "TC" and rear of "TE".



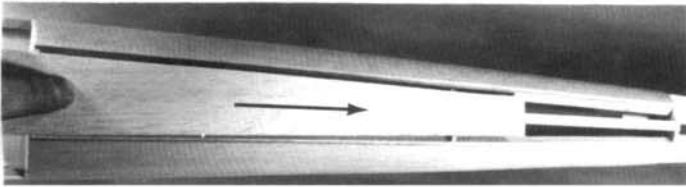

Slide top center sheet in position and glue in place. Trim to fit with side sheets.

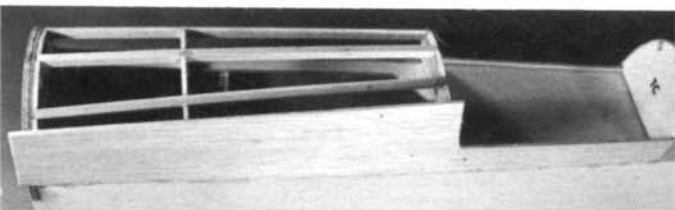

**25.**  Install 1/8" laser-cut front sheeting in same manner, applying side pieces first. Where 1/8" balsa butts against former "TC" glue a scrap of 1/8" sq. inside to reinforce the joint.

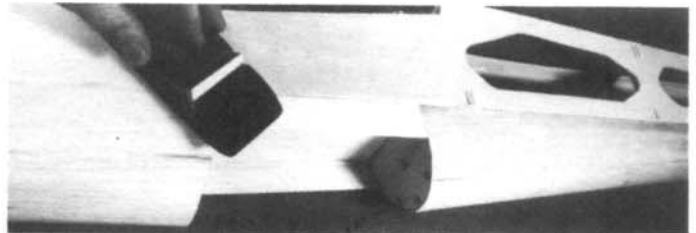
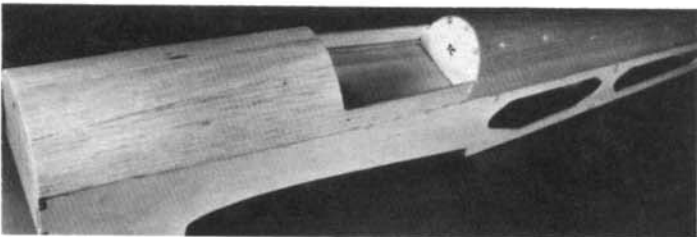
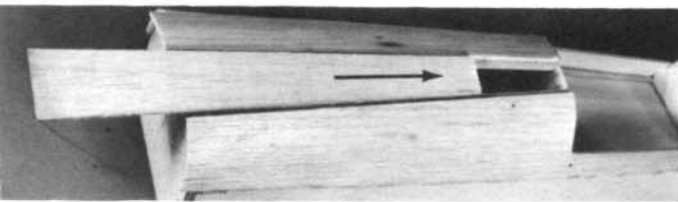
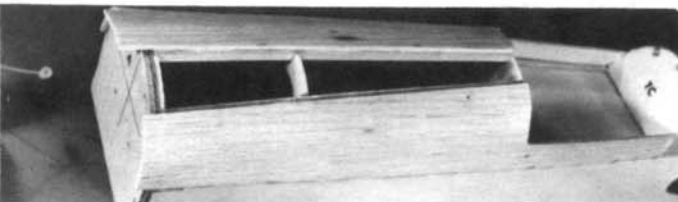

**26.**  Flat sand fuse and round off corners, except the following areas: top of tail mounting area, and wing saddle-repeat: do not sand these areas, except very lightly to remove burrs.

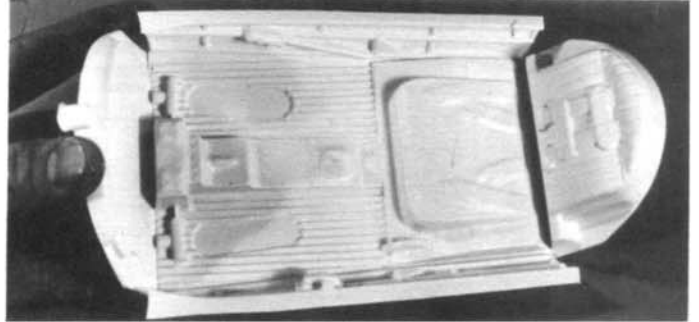

**27.**  Carefully remove scrap areas from formed cockpit as shown above.

Gently bend cockpit front, rear, and sides along formed seams-do not bend sharp or plastic will crack.

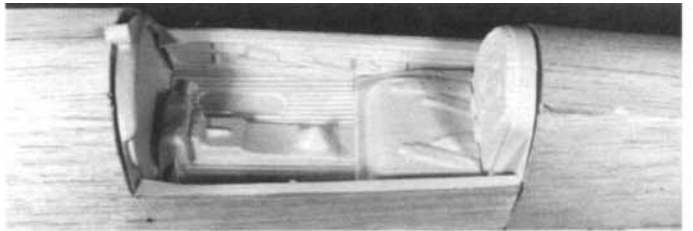

Temporarily place cockpit inside fuse, trimming as required for good fit.

Remove cockpit and set aside for painting.

**28.**  Bolt wing in place.

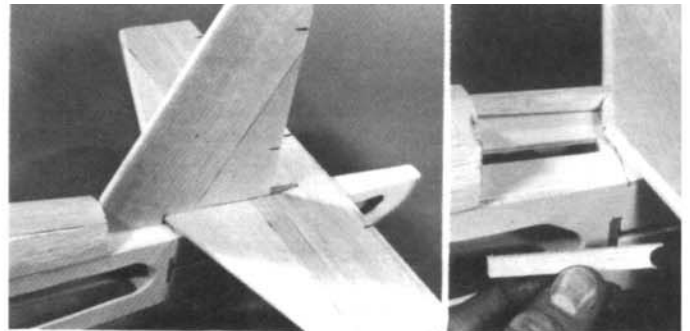

Center stab on fuse, measuring to obtain equal distance from side to side, and from nose of fuse to rear corner of each stab tip. View from rear to make sure that stab is level in respect to wing.

Trial fit fin in place, making sure that it points dead straight ahead.

When tail parts are aligned and square with fuse, make several reference marks. Remove fin and stab.

Using slow CA or epoxy, glue stab and fin in place. While drying, check parts for square and alignment.

Glue balsa filler pieces to fuse at front of stab.

## COWL ASSEMBLY

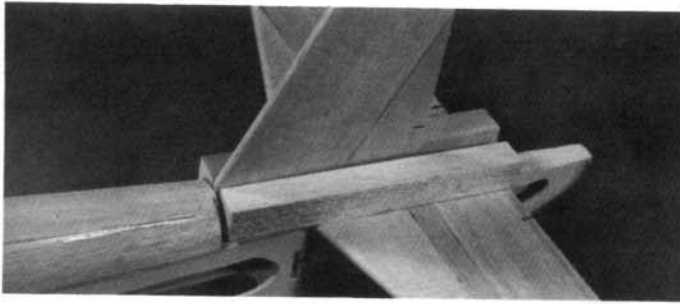

**29.**  Cut 7/8" sq.x16" balsa block into two 8' pieces. Then, taper sand to pointed fairing shape as shown in photos above and fuse views on plan.

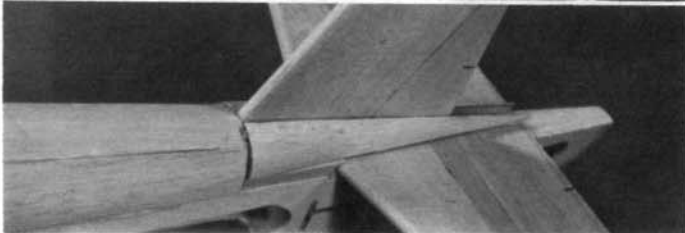
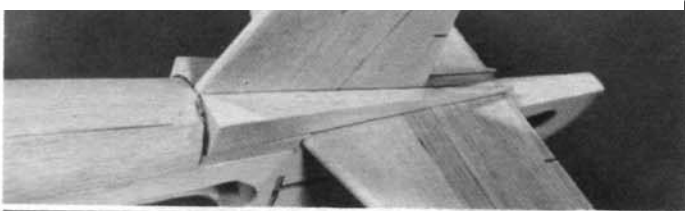

Glue fairings in place.

**DORSAL FIN- MAKE FROM 5/16" x 3/16" x 12" Balsa GLUE IN PLACE**

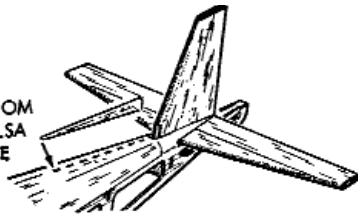

**30.**  Refer to fuse views on plan for installation of rudder pushrod guide tube through balsa fairing. Using a sharpened 1/8" wire, drill a hole for the rudder pushrod guide tube through balsa fairing and former "TE".

Position nylon rudder and elevator guide tubes in fuse as shown on plan (insert long threaded rods to hold tubes straight). Glue nylon tubes in place where they exit fuse rear. From scrap ply, cut braces to support tubes at formers "C" to "D". Glue tubes to former "C".

Remove wire rids and trim nylon tubes flush where they exit fuselage at rear.

Later, when installing your radio equipment, we recommend running the receiver antenna into the rear of the fuse. To make this easier to do, glue a length of plastic tubing, drinking straws, etc. from former "C" to "E".

To protect the engine area from becoming oil soaked, it needs to be "fuel-proofed". Either polyurethane, CA, or epoxy is good for this. Apply your fuel proofer to entire engine area, firewall, sides and fuse front. Open up screw holes with toothpick while paint is wet. Let dry thoroughly.



**1.**  Using the measurement from step 9, position and tack-cement engine on mounts (engine must parallel mounts and point straight out from firewall).

Carefully mark through engine mounting holes to mounts. Remove engine. Drill four 1/8" holes straight into and through mounts.



Install engine, muffler, and propeller and spinner.

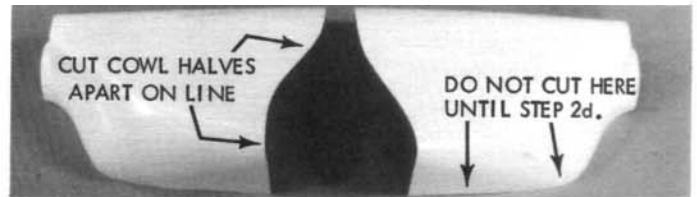

**2a.**  Cut cowl halves apart at center. Trim to match formed curved lines as shown in photo above.

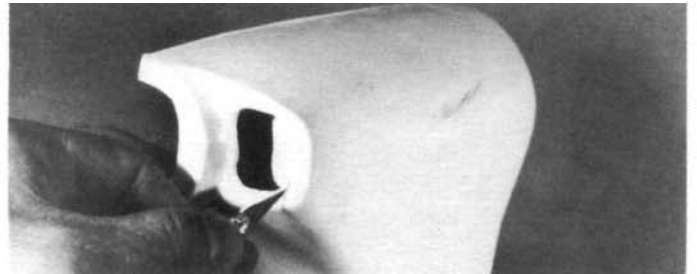

**b.**  Cut out opening for prop shaft and front air intakes.

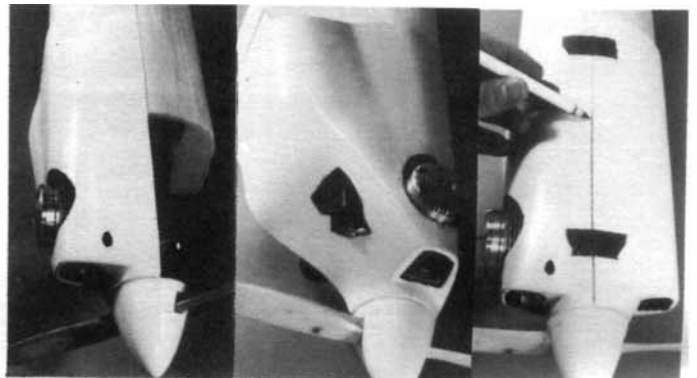

**c.**  Try fitting cowl half in position over engine (allow about 1/8" space between cowl and spinner). Observe and mark where openings must be made in cowl for engine/muffler clearance. Begin making these openings, cut a little at a time, trying and fitting and enlarging openings as needed. Do not try to rush this or you may ruin the cowl or worse yet cut yourself.

Try fitting other cowl half in place, cutting openings for engine/muffler as required.

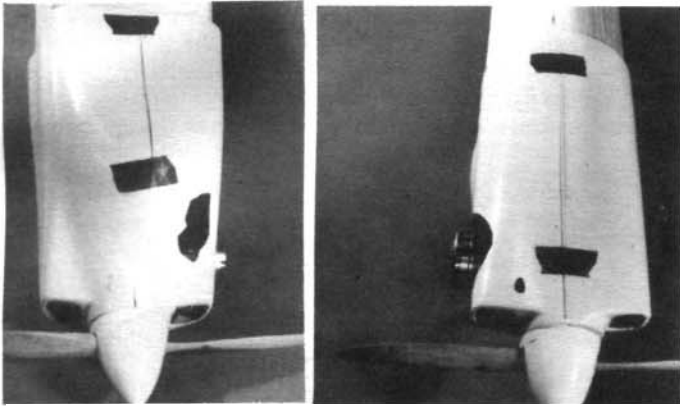

**d.** □ When both cowl halves fit around engine, tape them together at center joint. Check for overall fit of cowl, match-up with spinner, etc. If cowls must be overlapped to fit, mark and trim the overlap until both halves butt fit at center joint.

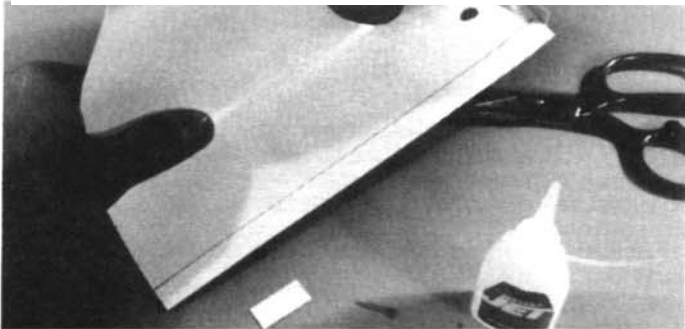

□ From long plastic strip furnished, cut and glue a joining tab along the inside edge of one cowl half as shown.

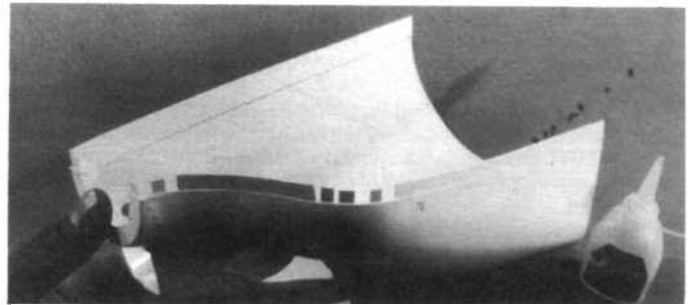

Lower strip must be cut into small segments in order to fit around curves.

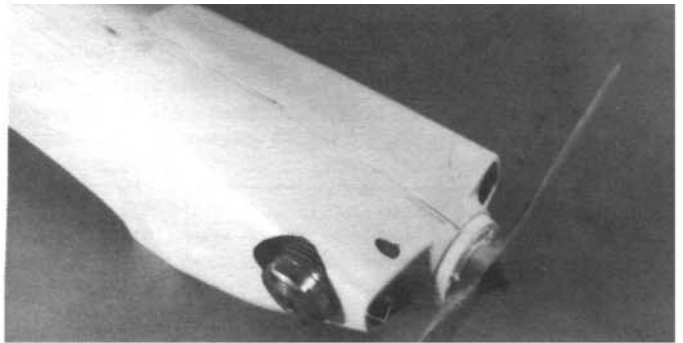

**e.** □ Glue cowl halves together.

□ Attach cowl to fuse using #2 x 3/8" screws and washers. At lower side screw locations, make spacers from scrap ply to fill gap between cowl and fuse. Glue spacers to fuse sides.

## IV COVERING

**General.** A good covering job should be preceded by careful sanding, filling nicks and dents, then more sanding. Use filler appropriate for balsa such as CG Model Mate. Any irregularities in the wood surface will show on the covering so a smooth sanding job is a must for good appearance. For final sanding, use fine sandpaper (grade 240 to 320) and a sandpaper block.

As mentioned earlier, the easiest way to finish your Chipmunk is to cover it in one color and then either paint it or apply the color scheme cut from covering material. Follow the manufacturer's instructions regarding applying multiple color paint schemes. If painting the color scheme, polyurethane spray paint is recommended.

Now is a good time to paint the cowl and canopy frame detail so they can be set aside to dry while you are covering the airframe. Cowl should be sanded smooth and joints filled with material suitable for plastic. Wipe down completely with a tack rag to remove all dust. Mask areas to be painted.

**IMPORTANT!** Raw fuel and engine oil residue, if allowed to puddle or stand, can eventually deteriorate the finish, resulting in loose edges of the covering and striping, peeling paint, etc. Wiping the model down after each flight will help maintain your plane's finish for years. Engine exhaust often affects details such as striping, etc. Careful applications of CA along the edges will hold them down securely in place.

Read instructions on paint can, and follow them. The first coat should be applied very lightly. Do not try to cover in just one coat or the paint will run! Repeat applications, gradually building up color density while allowing time between coats as specified by the paint manufacturer. Let final coat set a bit, then remove the masking tape carefully. Set aside away from your work area so it can dry free from dust or other damage.

**PAINING PLASTIC FILMS.** Modeling grade polyurethane or epoxy paints are recommended. To assure good paint adhesion to the plastic covering, the area to be painted should be washed with soap and water to remove surface grease and oil. Then dry thoroughly. You can also clean the surface with acetone. The design is then carefully masked; vinyl tape is best for this. Optional: gently wipe masked area with 000 steel wool to dull plastic surface for increased paint adhesion, being careful not to disturb the masking tape.

## COVERING THE WING

□ Using a fresh razor knife or blade, cut a piece of covering 1" larger in each dimension than one-half of the wing bottom. Strip protective backing from adhesive side.

□ With iron at proper working temperature, tack covering to perimeter edges of the panel, gently pulling out the main wrinkles as you go.

IMPORTANT: DO NOT cover plastic wing tips—the hot iron will permanently deform them. Align edge of covering so it butts or just covers the wing tip joint.

□ Pull the covering slightly taut as you go. Don't rely entirely on shrinkage to eliminate wrinkles and sagging.

□ Seal all around edges.

□ Glide iron over interior to tighten covering. Seal covering to all ribs. Trim edges.

Following the same procedure, cover entire bottom, then top. Immediately go back and slit covering to open aileron hinge slots while the locations are still fresh in your memory. Also, open the four strut mount holes in wing bottom. See plan for help in locating slots and holes.

□ Cover the ailerons (and flaps) in same manner, first the bottom, then the top, overlapping the covering around the edges.

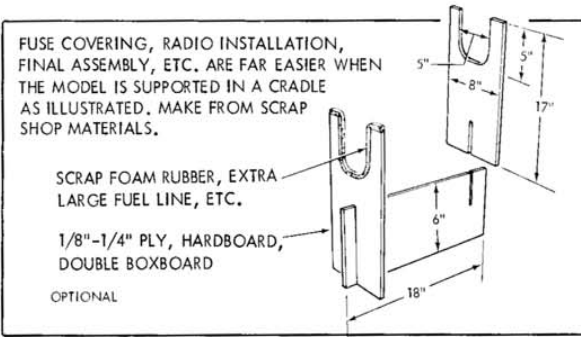

## COVERING THE TAIL

Following same procedure as the wing, cover the stab/elevator and fin/rudder. After covering over hinge slots, go back and slit covering to open slots while the locations are still fresh in your memory.

- Cover elevator (and elevator center section)
- Cover rudder
- Cover stab & fin & dorsal
- Cover fuse bottom

DRILL 1/8" HOLE FOR  
TAIL WHEEL WIRE

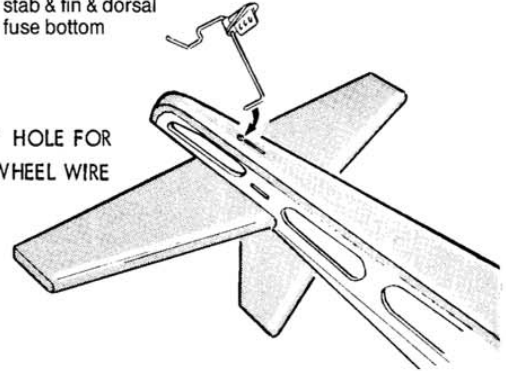

- Insert long end of tail wheel wire into nylon bracket until bent end contacts , hold with tape. Place tail wheel assembly over fuse side view on plan and bend to match shape as drawn.
- Insert this bent end up through fuse, then glue and screw nylon bracket securely to fuse.
- From scrap balsa, seal small gap between tapered tail filler blocks behind fin.

## FINAL ASSEMBLY

□ When the wing is in place, a seal is needed to protect against the entry of exhaust oil and dirt into the radio compartment. Also the seal acts as a cushion between wing and fuse to prevent abrasion of the covering. For this seal we recommend the use of silicone caulk. Since it dries slowly, save this step as the last of a building session. Tape plastic kitchen wrap around the wing center section. Apply a thin ribbon of caulk to the wing rest surfaces on top of the fuse. Install wing and bolt down moderately—do not wipe off the silicone that squeezes out. Let dry overnight. Remove wing and using a sharp blade, trim excess flush with fuse sides.

## FUEL SYSTEM

□ Install your fuel tank, hold it level by supporting the rear end with foam rubber as shown on the plan.

## OPTIONAL PRESSURE FEED

□ If your muffler has a fuel-line type fitting on it, you can use it to "pressure feed" to the engine for smoother and more reliable running. In this case, the vent line is connected to the muffler fitting.

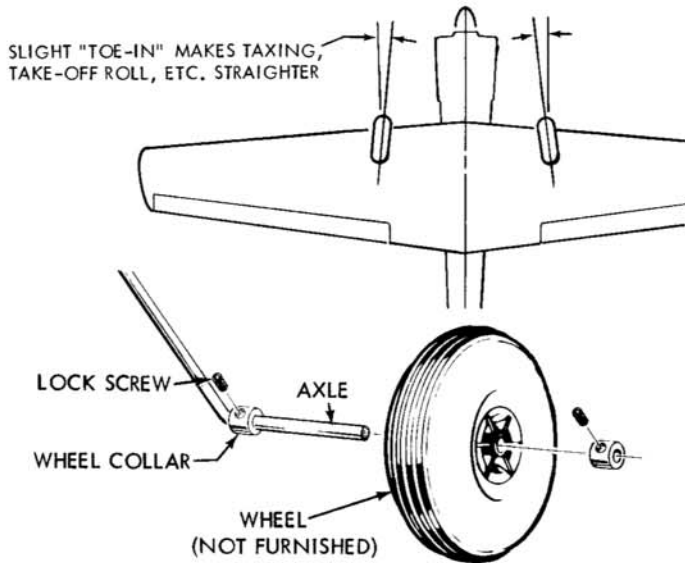

□ Install wheels on axles as shown: wheel collar and set screw first, wheel, then second wheel collar. If the axle hole in your wheels do fit the L.G. wire, enlarge holes with a 3/16" drill. Hold wheel loosely so it will center itself while drilling, and use slow drill speeds if possible.

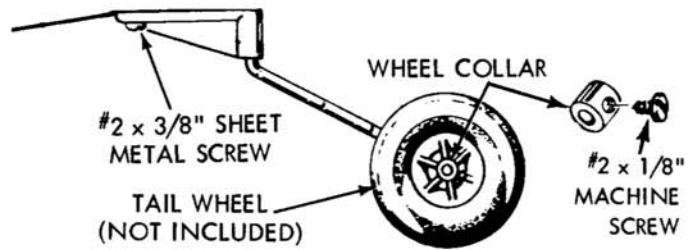

## LANDING GEAR STRUT FAIRING

□ From scrap balsa, make fairings as shown in fuse side view. The fairings must be installed so they do not interfere with the mounting or removal of the wheel pants. Also notice the top angle to allow clearance for rearward strut bending. Groove for wire strut and glue to wire. Apply covering material.

## PILOT FIGURE.

A pilot figure adds a final touch of realism especially during those low & slow fly-bys. Assemble and paint the pilot per manufacturer.

## CANOPY INSTALLATION.

□ Before gluing the canopy in place, temporarily set it in place on fuse and note where its outline contacts fuse. For better gluing lightly sand the covering in this outline area—light sanding only, just dulling the surface. And on the inside edge of the canopy, lightly sand a 1/8" band all around. For added gluing strength, make a series of pin-hole punctures through covering so glue can grab wood underneath. The most durable means of attaching the canopy is to strip a 1/8" wide ribbon of covering from the entire canopy/fuse contact area so the canopy can be glued directly to the balsa.

## DECAL

Clean model surfaces thoroughly before applying decals. Cut decal sheets apart in sections as needed. Fold decal in half, front to rear. Open at fold and lay decal out straight, the protective backing will bubble away from decal at fold location. Using scissors, cut backing along bubble, removing about 1" wide strip of backing. Carefully position decal on model and stick in place. Working from center, rub decal down while peeling off backing.

## OPTIONAL SMOKE SYSTEMS

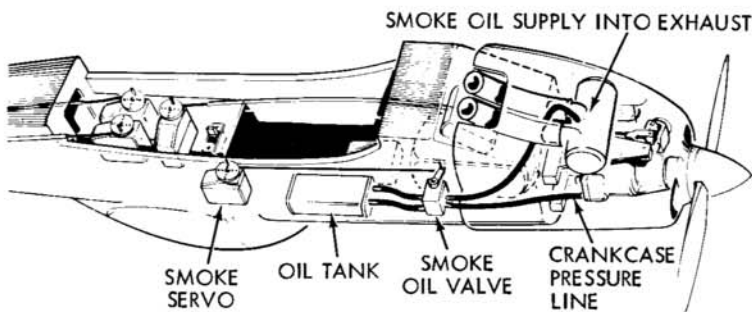

FOR 2-CYCLE ENGINE

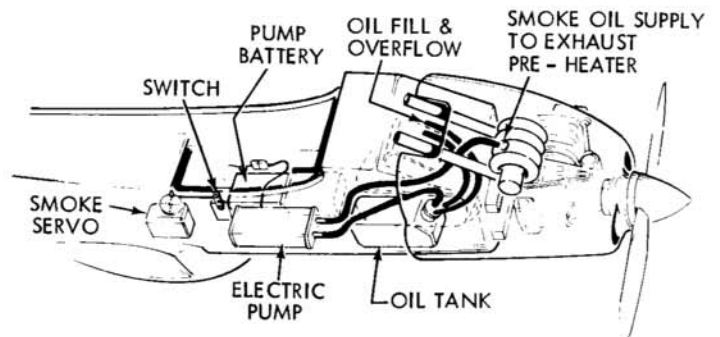

FOR 4-CYCLE ENGINE

## RADIO INSTALLATION

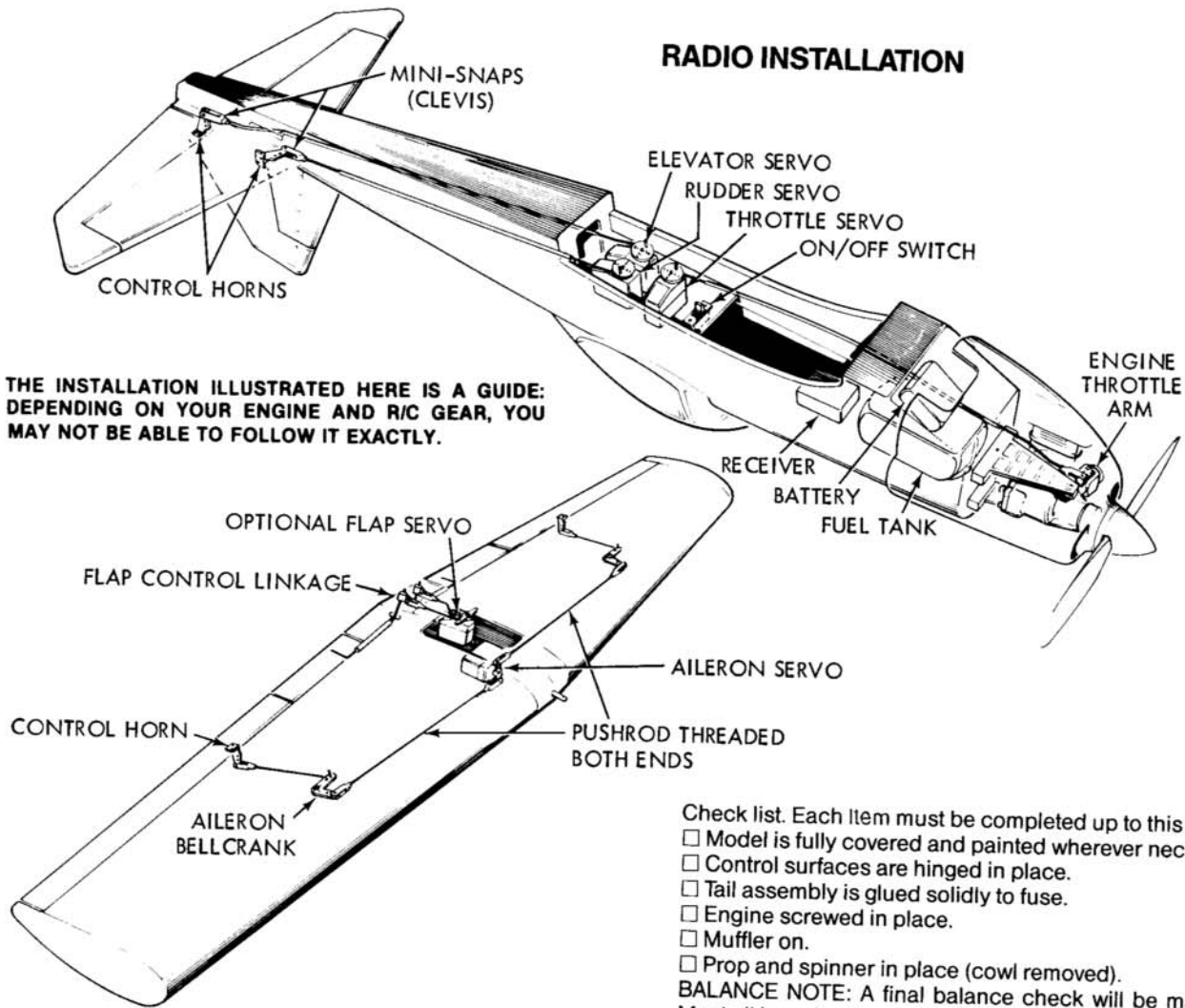

- Check list. Each item must be completed up to this stage.
- Model is fully covered and painted wherever necessary.
  - Control surfaces are hinged in place.
  - Tail assembly is glued solidly to fuse.
  - Engine screwed in place.
  - Muffler on.
  - Prop and spinner in place (cowl removed).

**BALANCE NOTE:** A final balance check will be made later on. Most all brands of equipment when installed as shown will result in a properly balanced condition.

### 1. Radio Installation.

- A. Read and follow the instructions that come with your radio.
- B. Your batteries should be fully charged.
- C. Hook-up Radio and Try Operation.

- Refer to "Transmitter Function Sketch" and observe which servo wheels move when stick is moved for various controls.

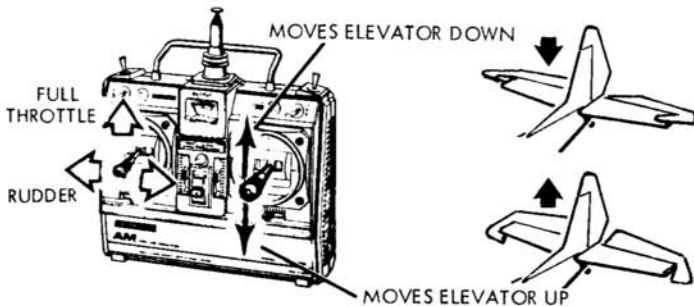

- Apply tape (which you can write on) to each servo. Identify each servo for its control function. Mark the plug to each servo the same way: "R" for rudder, "E" for elevator, "T" for throttle, "A" for ailerons. If your receiver doesn't have separate plugs for each servo, but places for the servos to plug in, apply a piece of tape nearby that you can mark for each application.

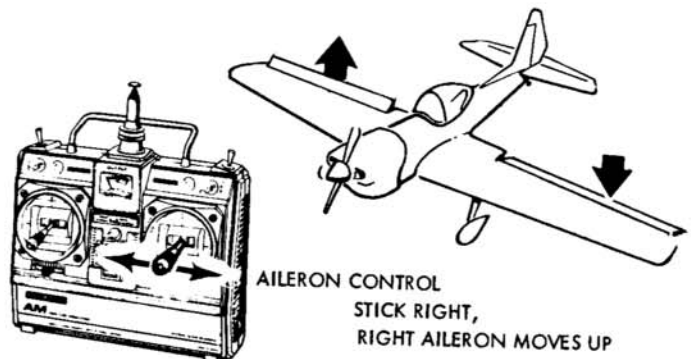

### 2. Servo Movements.

As mentioned in the introduction on page 2, radio systems with "servo reversing" simplify radio installation. With a **regular non-reversing** system, you must match each pushrod to its corresponding servo's rotation. With "servo reversing," pushrods can be hooked up to either side of the servo's output wheel, and after checking the control response, a servo responding in the wrong direction is easily switched to correct action (see your radio manufacturers instructions).

The arrangement on the plan shows standard servo placement for a "servo reversible" system. Check your equipment out with the following procedure.

"REVERSE" SERVO CAN BE IDENTIFIED BY A DOT IN MOUNTING FLANGE AS SHOWN HERE. OR A DIFFERENT COLOR CASE OR MARKINGS.

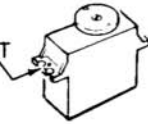

In radio sets without a "servo reversing" feature, the rudder servo is usually a "reverse" servo. A "reverse" servo can be identified by a dot (see above), or a different color case or markings.

- Move the elevator stick up, and observe where the elevator pushrod must be attached to the elevator servo to pull the elevator down. Mark servo.
- Move the aileron stick to the right, and observe that the right aileron must be connected so it moves up.
- For flap, smoke, or retract options, keep servo movements for these functions in mind as you install the various systems.

### 3. Mounting the Control Horns and Pushrods.

#### Rudder Horn

- Refer to fuse side view on plan for correct location.
- Position control horn on rudder so mounting screws straddle the tail wheel wire, captivating it between them. Tack-cement in position.

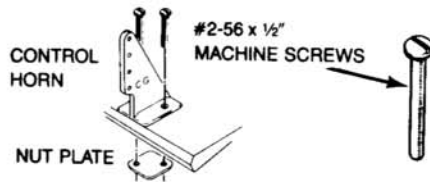

- Drill through holes in horn, and mount nut plate on other side using screws as shown. Trim screws flush with nut plate.
- Lay long threaded wire over pushrod views on plan, and make bends at tail as required. Feed wire into nylon guide tube at tail and insert it through to the radio compartment area.



- Twist Mini-Snap (clevis) onto threaded end. Hold wire with pliers while installing mini-snap. Connect to rudder horn.

#### Elevator Horn

- Position elevator horn so that screws will captivate the elevator joiner.
- Tack-cement horn in position. Drill through holes in horn, and mount nut plate on other side using screws as shown. Trim screws flush with nut plate.
- Insert unthreaded end of other long threaded rod into side guide tube and forward into fuselage. Allow about 2" of threaded end to remain out tail.
- Install Mini-Snap, and connect to elevator horn.

#### Aileron Control Horns

- Install Mini-Snap on aileron pushrod.
- Refer to plan and position horn on aileron. With aileron pushrod centered in wing slot, align horn with it (do not connect yet). Tack-cement horn in place, drill and mount. Repeat for other aileron.

### 4. Mounting Servos, Using Die-Cut Servo Tray.

- Insert the soft rubber grommets into your servos.
- Glue 1/8" ply front servo tray support into notch locations in fuse doublers.
- Refer to plan views and engage rear of die-cut servo tray with side notches in former "C". Glue servo tray to former "C" and to front support rail.

- Correctly position servos in tray and gently fasten them in place with #2 x 3/8" sheet metal screws.

### 5. Installing The Throttle Pushrod.

- Determine the most direct practical route from the throttle servo to the engine throttle arm. Mark and drill a 3/16" hole through firewall for outer pushrod tube. Insert 3/16" tube through firewall hole, side slot in former "B" and into radio compartment, allow about 3/8" nylon tube to project out front from firewall. Cut rear end of tube about 3-1/2" from throttle servo. Slide 3/32" inner tube through it.

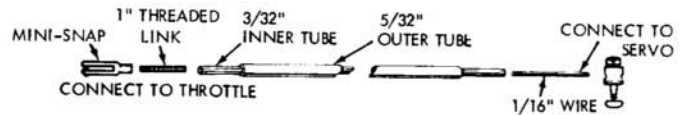

- For throttle hook-up, screw 1" long threaded link into front end of inner tube. Install Mini-Snap on threaded link and connect to throttle arm.
- At rear end, make connection to servo by gluing a straight length of 1/16" wire into the inner tube; first roughen the wire with sandpaper, then Super Jet about 1/2" of it into tube.



- On long 4-cycle engines with rear mounted carbs, the throttle arm may be very close to the firewall. In this case, the pushrod installation shown on the main plan view should not be used. Instead, substitute this method. Install the outer pushrod flush with the firewall as shown in sketch above. Cut the inner tube to a shorter length so that it lies recessed inside the outer tube and only the wire protrudes for hookup to throttle arm. This results in a very direct, neat installation.

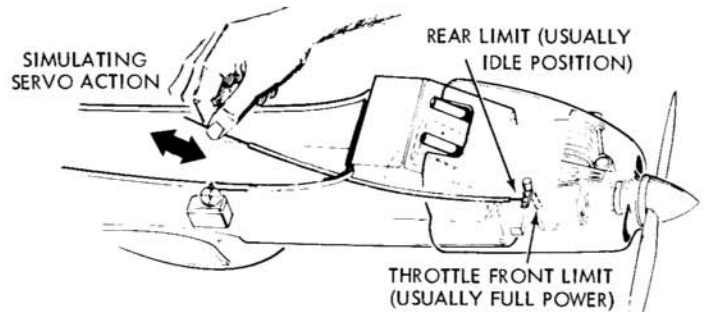

- Move pushrod back and forth to simulate servo action. The pushrod should move freely; if not, adjust where necessary. Feel the front and rear "limits" of the throttle arm. Later, when setting controls, be sure to set the throttle servo linkage within the range of throttle arm movement. Glue guide tube to firewall, former B, and fuse side. If the guide tube needs support, make a "stand-off" from 1/4" scrap balsa (see plan). Tailor the stand-off to suit the curvature of your installation, glue it only as required so it doesn't interfere with pushrod sliding action.



- Remove servo wheel, and install the CG Pushrod Connector as shown. This device lets you easily adjust throttle pushrod movement. Remount servo wheel.

Make sure throttle servo is at idle position. Engine throttle arm also should be at rear or idle position. Align and cut the pushrod wire so it extends 1/4" to the rear of the pushrod connector, and attach. Check action with radio, and if OK, throttle pushrod hookup is completed.

### 6a. Hooking Up Elevator and Rudder Pushrods.

- Remove elevator and rudder servo wheels (or arms). Using a 5/64" dia. drill, carefully enlarge respective holes for connection of 5/64" elevator and rudder pushrod wires.
- Position elevator pushrod so that the elevator is flat with stab. Allow additional 5/16" past servo wheel hole, then cut and bend forward end of pushrod. Roughen bent-up wire with sandpaper, remove servo wheel and insert wire, and retain with snap-nut.
- Position rudder pushrod so that the rudder is aligned with fin. Cut and bend forward end of pushrod as above, and attach to rudder servo wheel.

### 6b. Hooking Up Optional Flaps.

- Bend and solder pushrod wires together as shown on plan, but do not cut pushrod at servo end yet, when radio is operational the final hook-up and setting of flap movement will be done. Install all linkages as shown on Wing Plan.

### 7. Installing Switch and Charging Jack.

- Drill a 1/16" dia. hole through switch tab for 1/16" wire. Mount switch in opening provided in servo tray. On fuse side opposite exhaust, drill a 1/16" dia. hole in line with switch. From scrap 1/16" wire, make a switch pushrod as shown in Fuse Bottom View on plan. Glue wire into switch, or retain with optional 3/32" wheel collars as shown.
- Position charge jack cover plate on outside of fuse and mark through plate for holes and openings. Make holes and mount jack.
- Later when radio is operating, identify ON and OFF position with decals provided.

### 8. Battery Pack.

- You must have fully charged nicads for flying.
- Wrap battery in 1/2" very soft foam rubber to cushion it from vibration and shock. Use rubber bands or tape to hold the foam around the battery. It is also good to place battery and Rx in individual plastic bags to protect against fuel and oil.
- Position battery in fuse, and hold in place with scrap ply rails.

### 9. Receiver (Rx).

- Do not cut the antenna wire attached to the Rx.
- Wrap Rx carefully in foam like the battery.
- Re-connect all cables so R/C system is operational; be sure that each servo is plugged into its respective Rx terminal.
- Place Rx in fuse behind the battery.
- Insert antenna in rear fuse antenna tube.

### 10. Setting Control Surfaces.

All pushrods must move freely, without binding; adjust if required for smooth operation. When setting control travel, be cautious that no servo is hooked to a control in a manner that prevents the servo wheel from moving through its complete range of rotation. For example, if the throttle servo "buzzes" when moved to "full-throttle" position, the servo still has movement left, but is jammed against the engine's full-throttle limit position. This can damage the servo and drain the battery, leading to loss of control, and a crash.

The following instructions describe how to set the control surfaces measuring up and down movement using the angle templates provided.

For first flights, it is recommended that you set controls per the angle templates for "softer" control response. Later, after you are more familiar with the airplane, you can always increase the throws as you prefer.

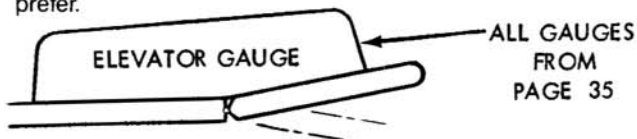

- With elevator trim tab on Tx set in center, adjust elevator mini-snap until top of elevator is flat with top of stab as shown above.
- Move the elevator stick on Tx full up and down. The elevator should move to match template angles, up and down.
- With rudder trim tab on Tx set in center, adjust mini-snap until rudder aligns perfectly with fin. Tail wheel should point straight ahead.
- Move the rudder stick on Tx full right and left. The rudder should move to match the rudder template angle, left & right.
- Move throttle lever on Tx to cycle the throttle from idle to full power. Minor adjustments can be made by shifting the mini-snap location on the engine throttle arm.



- With aileron trim tab on Tx set in center, adjust and connect mini-snaps until ailerons are neutral with wing. Move the aileron stick full right and left. The ailerons should move respectively up and down to match aileron template.

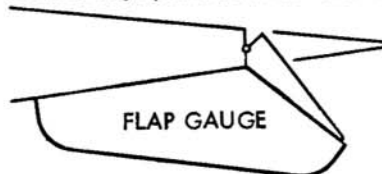

- Move the flaps from full "UP" position to full "DOWN" position (use the gauge for DOWN position). Observe the movement of the control horns as compared to the distance the flap servo arm moves when the Tx flap lever is moved from flaps "UP" to "DOWN". Determine the best nylon bracket position on horns and servo arm hole combination that will provide the required flap movement. Cut and bend pushrod wire and complete the flap hook-up as shown on plan.



- Enlist someone's aid to help you balance the model as shown. If you must balance it alone, make the simple balance stand at left from scrap lumber (2x4, etc.) to assist you. **IMPORTANT!** Also refer to balancing instructions on page 19!



## PRE-FLIGHT & BASIC AEROBATICS

The following is presented as a pre-flight review for safe and enjoyable flying. If you have been flying only tricycle gear models, you should have little, if any problem getting used to take offs and landings with a tail wheel. For take off, remember to feed in right rudder as required to keep the model rolling straight ahead. Very little right rudder is needed.

If you have never successfully flown an R/C model before, do not try to teach yourself to fly this higher performance model.

Even full-scale pilots have problems learning to fly models, because it's different - they're not in the cockpit. We strongly recommend that you learn with a high wing trainer, such as the

### GETTING READY TO FLY YOUR CHIPMUNK

Taking your time here really pays off at the flying field. Many modelers rush the last stages of building and setting up and never realize the full potential of their airplane. The Chipmunk, if you follow our instructions, is a very easy to fly performance model capable of executing all maneuvers very well.

Lets start with what type of flying you intend to do. If you are a relative new comer to aerobic flying or this is one of your first low wing planes use the more forward balance location and the GENTLE CONTROL deflections as provided by the angle gauges

### VIII RADIO CHECK

Before going to the field to fly, with batteries fully charged, turn on receiver and transmitter and actuate all controls many times until you are satisfied with all functions. Stand behind the model, and make sure that the control responses are correct. Move the control stick to the right and the right aileron should go up. Moving the stick back or down on the Tx should move the elevator up, and vice versa.

Check also to see that your tail wheel turns to the right when you give right rudder. Your throttle should open to permit full power when the stick is moved forward or up. Make sure that everything is neatly and firmly in place—engine fastened down, servos snugged down, receiver and battery wrapped in foam rubber, tank properly supported, etc. Prop must be tight. Nothing should be loose, or unfinished, or unchecked. Receiver antenna must be extended, not coiled up inside the model.

Prior to the beginning of each day's flying, make a range check of your equipment in accordance with the manufacturer's instructions. In general, with transmitter antenna collapsed to 6" to 8", you should have at least 100 feet range on the ground. To check this, turn on both the transmitter and receiver switches, set the model heading away from you, and walk away while transmitting signals. Watch to see that no signals are missed until you are at least 100 feet away. Only if the equipment works perfectly should any flights be attempted. **Be careful not to use your transmitter when someone else on the field is flying or testing on the same frequency.**

### FIRST FLIGHT

After everything checks out—check it again! Many models have been lost due to reversed ailerons, a mini-snap or unreliable engine idle.

After performing a range check, taxi around to get a feel for all controls while taxiing always use full up elevator and try not to "blip" the throttle. Smooth is the way to go. You may even want to do some high speed runs down the runway.

To take off, follow this procedure. Point plane into wind. While holding full up elevator apply full power (not too quickly) you might need about 1/3rd right rudder to keep it straight. After about 15 feet you will need to slowly release the full up elevator just a bit in order to lift when the model has reached flying speed. After take off you may want to hold some right rudder during the climb out.

EAGLE 63 or EAGLET 50, and that you ask your dealer for guidance.

### VII WHERE TO FLY YOUR MODEL

Fly only in areas sanctioned for R/C and known to be free of radio interference. If you don't know the whereabouts of an R/C club near you, write the Academy of Model Aeronautics (AMA) and ask if they have a club on file in your area. Most clubs are chartered with the AMA, and we recommend you become a member. Their address:

Academy of Model Aeronautics  
1810 Samuel Morse Drive  
Reston, VA 22090

### GETTING READY TO FLY YOUR CHIPMUNK

(the idea that the more control movement you have the better is totally wrong). Finally, even the experienced pilots should start with the gentler set up and work their way to what they feel most comfortable with.

	GENTLE CONTROLS	AEROBATICS
AILERONS	11°	13°
ELEVATOR	11°	12°
RUDDER	17°	20°

ALL THE ABOVE SETTINGS ARE AT HIGH RATE

### CHECK STEERING THE MODEL ON THE GROUND

With everything ready, the engine should be started and broken in for at least a tank or two at no more than moderate speed. While the engine is running, the control surfaces should not jitter or move until you command them. The throttle also should respond to your command.

Apply minimum throttle so that it just keeps the model moving at a walking pace. With rudder stick and rudder trim in neutral position, the model should move straight ahead. If it constantly turns left or right, the tail wheel is not pointing straight ahead, and should be adjusted until it is correct. After taxi runs are completed, thoroughly examine the model, and tighten loose screws, etc.

### PRE-FLIGHT CHECK LIST, THINGS TO DO, AND THINGS TO TAKE TO THE FIELD

- Flight batteries fully charged
- Radio transmitter (DON'T LEAVE IT AT HOME!)
- Fresh 1-1/2 volt starting battery & Glo plug clip
- Tools to tighten anything that can vibrate loose
- Fuel and fuel bulb or pump
- Paper toweling (for clean up)
- SUPER JET
- Extra props
- Prop wrench

The first flight should be short, 2 to 3 minutes to trim out the ailerons and elevator, and to get a general feel of the controls. Then land, you will find the approach is average—not tricky. Just keep the airspeed up until on the ground. Hold up elevator to prevent nose overs during roll-out.

Before second flight, take off wing and check all screws, etc. make sure everything is snug. Especially engine, muffler, etc.

## AEROBATICS MADE EASY

Before starting any aerobatics you must have your Chipmunk totally trimmed for straight and level flight and a reliable engine.

Almost all maneuvers are a combination of loops and rolls, so if you can do a good loop and roll—you're on to a great start!

We highly recommend the book **Flight Training Course, Volume II**, published by **R/C Modeler Magazine**, a small portion of which they have graciously permitted us to reprint here.

On your previous R/C plane, you probably have already tried some of the maneuvers shown here. We present them as an introduction and review of a rewarding aspect of R/C flying — carefully planned and executed flying technique. It's something even expert pattern flyers must practice diligently. An apparently simple thing such as "Touch and Goes," and flying a tight, well-defined traffic pattern are really basic to performing accurate and precise advanced maneuvers.

"Touch and Goes" are an exercise in approach planning, airspeed control, and smooth use of the throttle. These are important

elements for all advanced maneuvers. And they will be flown only as crisp and graceful as you want them to be since "practice does make perfect!"

"Which Side is Up?" The business about learning to recognize which side is up may sound foolish, but many a plane has bitten the dust because the pilot thought it was flying one way and it was going another. Other than learning to recognize the plane's silhouette at different angles and attitudes, the best insurance is to learn to keep your head on what you're doing. That is, force yourself to remember where you've come from as well as where you're going. For example, if you concentrate on the fact that you're making a left turn, you'll probably never mix up that silhouette in the sky. If you look away though or forget what the plane is doing, coming back to it can cause a few new grey hairs!

## TOUCH AND GOES

In doing a Touch and Go you'll be putting three things together that you've already worked on: the final leg of the Traffic Pattern Approach, the Landing Perfection, and the Takeoff. The only thing that's added is making the transition from the touchdown to the takeoff while the plane is still rolling. And, you have to be able to put your plane down on the runway with enough room left over for a smooth takeoff and gradual climb out.

*What The Touch And Go Looks Like.*

The plane is flying at about 25-foot altitude at about 200 feet from the end of the runway flying into the wind. The engine is either running at an idle or nearly so with the plane sinking gradually toward the runway in a slightly nose-down attitude. When the plane reaches about 6-foot altitude, the glide path levels off in preparation for the flare out and final touchdown.

When the plane touches down, it slows down to approximately 1/4 the flight speed. Without stopping the plane begins accelerating and lifts off. The lift off and climbout is gradual and smooth.

PLANE THROTTLED DOWN HOLDING SOME UP ELEVATOR FOR DESCENT

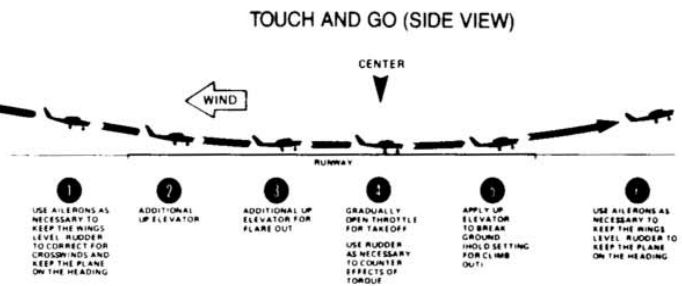

## THE LOOP

This is a good one to start with because it's usually the first "stunt" the new pilot has the guts to try. Another reason is that, at first glance, there seems to be nothing to it.

*What The Maneuver Looks Like.*

The model starts the maneuver flying straight and level into the wind. Then it pulls up into a smooth, round loop. The up and down portions should be straight up and down with reference to the ground. That is, the plane shouldn't fall off to the left or right. The speed of the plane should be constant throughout the loop.

As the plane finishes the loop, it should pull out in a straight and level flight at the same heading and altitude as it entered the loop and fly off for 50 feet.

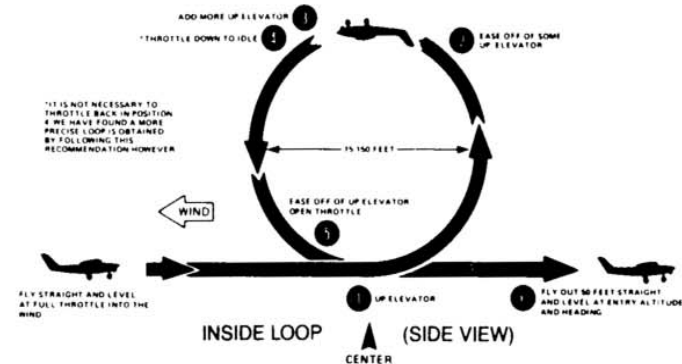

## THE HORIZONTAL ROLL

Before you get going on this one, here are some things you should know. First, and perhaps most important to keep in mind, is that **when the plane is inverted the elevator works backwards**. When the plane rolls through the inverted position, you give **down** elevator to keep the plane's nose up. Think about that one for a minute. It's important.

And don't forget:

1. Fly at an altitude that will give you a good margin for error, especially since you'll probably end up in a 30-degree dive on your first tries.
2. Practice with the plane in front of you rather than over your head, and with the sun behind you.

FLY STRAIGHT AND LEVEL AT FULL THROTTLE DOWNWIND

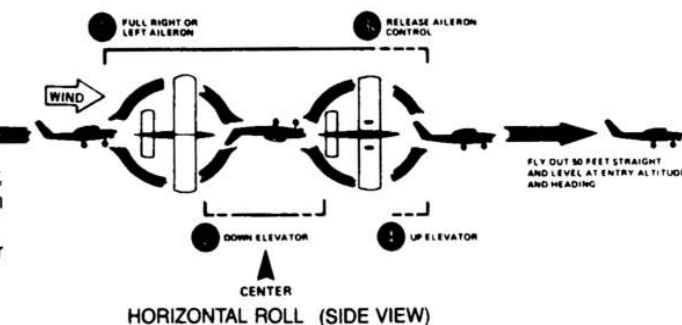

## THE STALL TURN

Getting the plane in a vertical climb and applying rudder at the proper time is what the Stall Turn is all about. Too soon, and you'll only wag your tail. Too late, and it won't do any good — the plane will just stall out and fall off. So, to get the Stall Turn to happen as it

should, you have to be able to get the vertical climb vertical. Recognize that second or two just before the plane stalls out — while there is still enough air moving over the rudder and apply the rudder. That gets the tail moving so it will continue to coast around while the plane stalls out.

**What The Stall Turn Looks Like**

The Stall turn, or hammerhead, is one of those smooth, pretty maneuvers. Flying straight and level, past center about 100 feet, the plane pulls up sharply into a vertical climb. As it climbs, the engine idles down and the plane begins to slow down as if it has run out of gas. When it looks as though there's no more oomph left, the plane pivots 180° on its left or right wing tip and heads straight down. Under control all the way.

When the plane gets to the entry altitude, it pulls out, heading in a direction opposite the entry and levels off. The throttle opens up and the plane flies off. Neat.

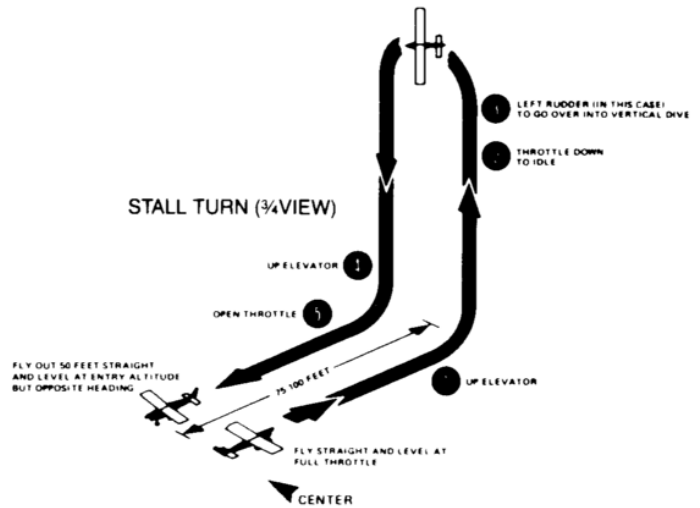

**INVERTED FLIGHT**

Perhaps the easiest and safest way of getting your plane inverted the first time is through the "stretched loop." You just fly into the first part of a loop. When the plane gets to the top, it's inverted. Then to come out of it, finish the loop. That's all there is to it. Get your plane out a bit. Then make a turn so it's flying full throttle downwind toward you.

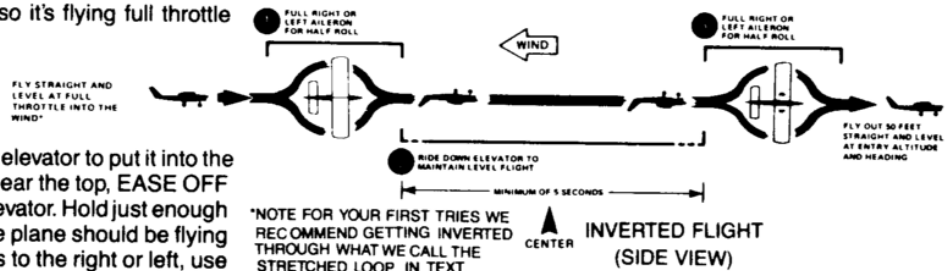

As the plane passes in front of you pull up elevator to put it into the "up" side of a loop. When the plane gets near the top, EASE OFF of the up elevator and put in some down elevator. Hold just enough down elevator to keep the plane level. The plane should be flying away from you inverted. If the plane banks to the right or left, use the ailerons to straighten out. Aileron response is the same inverted, put in some more down elevator. If it climbs, because you're giving it too much down, ease off of some down elevator. Find the right amount of down elevator to hold for a level inverted flight path. After the plane has flown inverted a couple of seconds or so, reduce throttle and finish your loop. Ease off of the down elevator and pull up elevator. The plane should dive down to finish the loop you started earlier and come out in straight and level flight toward you.

\*NOTE FOR YOUR FIRST TRIES WE RECOMMEND GETTING INVERTED THROUGH WHAT WE CALL THE STRETCHED LOOP IN TEXT.

used to seeing what the plane is doing up there. Practice flying inverted using the stretched loop entry until you feel comfortable keeping pressure on that down elevator and can hold straight and level flight inverted. As you get it working for you, increase the length of your inverted flight.

After you're more comfortable with flying the plane inverted, try getting into it using a half roll to the left or right to get inverted, fly inverted, then, half roll to the left or right to come out of it. To get into it, get your plane up to a safe altitude. Pull up a bit into about a 30 degree climb for more insurance.

Fly only a couple of seconds or so on your first times until you get

**MEASURING GAUGES FOR GENTLE CONTROLS.**

