

Lanier R/c Stinger .60 ARF

STINGER .60 ARF

INSTRUCTIONS



WARNING! THIS IS NOT A TOY!

THIS IS NOT A BEGINNERS AIRPLANE

This R/C kit and the model you will build from it is not a toy! It is capable of serious bodily harm and property damage. It is your responsibility, and yours alone - to build this kit correctly, properly install all R/C. components and flying gear (engine, tank, radio, pushrods, etc. and to test the model and fly it only with experienced, competent help, using common sense and in accordance with all safety standards as set forth in the Academy of Model Aeronautics Safety Code. It is suggested that you join the AMA and become properly insured before attempting to fly this model. If you are just starting R/C modeling, consult your local hobby dealer or write to the Academy of Model Aeronautics to find an experienced instructor in your area.

Write to : Academy of Model Aeronautics, 5151 Memorial Dr, Muncie, IN 47302

LIMITED WARRANTY

Lanier R/C is proud of the care and attention that goes into the manufacture of parts for its model kits. The company warrants that for a period of 90 days, it will replace, at the buyers request, any parts or material shown to the company's satisfaction to have been defective in workmanship or material at the time of purchase.

*Lanier R/C INC. P.O. Box 458 Oakwood, GA. 30566
Phone 770 532 6401 FAX. 770 532 2163*

© Copyright 2002 Lanier R/C Inc.

Lanier R/c Stinger .60 ARF

No other warranty of any kind, expressed or implied, is made with respect to the merchandise sold by the company. The buyer acknowledges and understands that he is purchasing only a component kit from which the buyer will himself construct a finished flying model airplane. The company is neither the manufacturer of such a flying model airplane, nor a seller of it. The buyer hereby assumes the risk and all liability for personal or property damage or injury arising out of the buyers use of the components or the finished flying model airplane, whenever any such damage or injury shall occur.

Any action brought forth against the company, based on the breach of the contract of sale to the buyer, or on any alleged warranty thereunder, must be brought within one year of the date of such sale, or there after be barred. This one year limitation is imposed by agreement of the parties as permitted by the laws of the state of Georgia.

*Lanier R/C INC. P.O. Box 458 Oakwood, GA. 30566
Phone 770 532 6401 FAX. 770 532 2163*

Lanier R/C Stinger .60 ARF

Wing Assembly

Locate the 1/4" x 1-3/8"x 117/8" dihedral brace and trial fit it into the slot in the wing. Align the hole for the hold down dowel in one half with the hole in the wing. If it does not line up perfectly try turning the brace end for end or flip it over. When the holes are aligned slip a dowel or a pencil in the holes and put the other wing half in place. When satisfied with the fit, take the wing apart, remove the dihedral brace and mark it so you can put in back in the same direction.

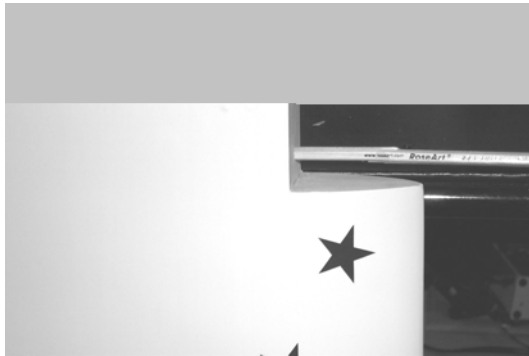

Apply a liberal amount of 30-minute epoxy in the slot on both wings, coat the mating surfaces of both wing panels, and coat the dihedral brace. Put the dihedral brace in one wing panel, apply epoxy in the dowel holes, and insert the 9mm wing hold dowels in the hole to keep it in alignment and slide the other wing panel in place. Let the wing hold down dowels extend 1/2" out in the front.

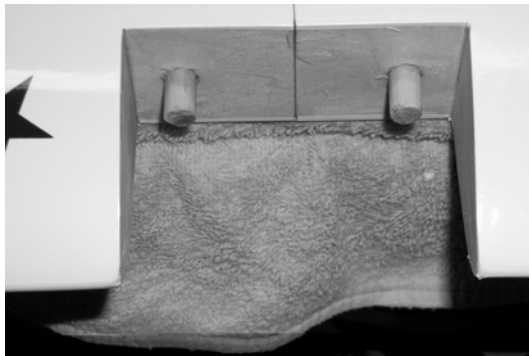

Use 4 pieces of masking tape about 2 feet long and pull them across the center span wise. Use two on top and two on bottom.



Use alcohol and paper towels and clean off all the excess epoxy before the glue dries. Set the assembly aside to cure.

Stab and Fin Mounting

Remove the elevator from the stab and slide it into the slot on the rear of the fuselage. Measure from the fuselage side to the tip on both sides and move the stab till it is the same.



Measure from the tip of the stab to the front edge of the turtle deck on both sides and move the stab till both sides are the same.

Lanier R/C Stinger .60 ARF



This should have the stab centered up in the fuse and the trailing edge of the stab perpendicular to the centerline of the fuse. Mark the stab along the sides of the fuselage top and bottom on both sides. Remove the stab and very carefully cut the covering 1/16" inside the line. Don't cut so deep that you cut the wood, as this would weaken the stab.

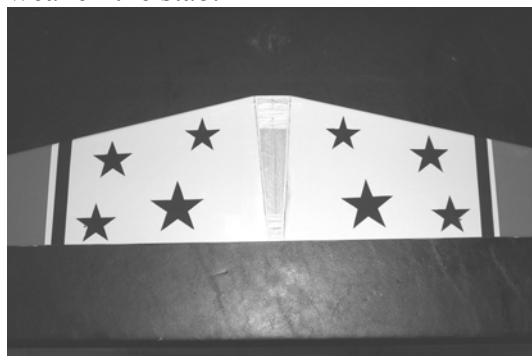

Remove the covering on top and bottom of the stab between the lines. You can now reinstall the stab in the fuselage. Carefully realign the stab on the marks you made. Now set the wing in place and viewing the plane from the rear make sure the stab is parallel to the wing. You can move the stab a small amount without removing any wood from the opening in the fuselage. It should not take more than this to align the stab.

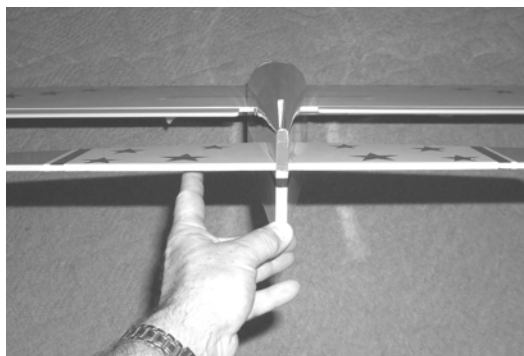

When satisfied with the alignment, glue in place. You can use medium CA or epoxy here.

Slip the vertical fin in place in the slot on the top of the fuselage, and check that it is square to the stab. You can move it a small amount without removing any wood. When satisfied with the alignment glue in place.

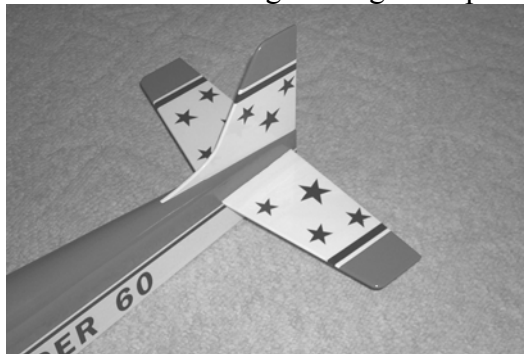

Landing Gear

Locate the landing gear, the three 5mmx16mm bolts and the three flat washers. Use locktite and bolt the gear in place on the fuselage. The blind nuts are already installed.

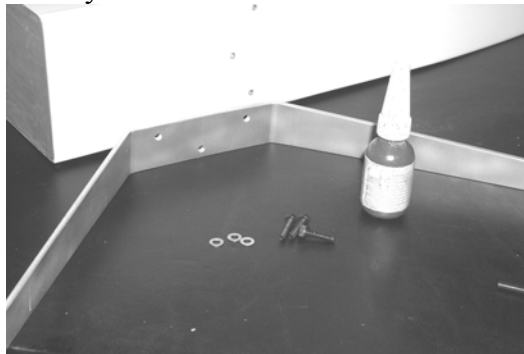

Lanier R/c Stinger .60 ARF

Locate the two axels, two washers, and two aircraft lock nuts.

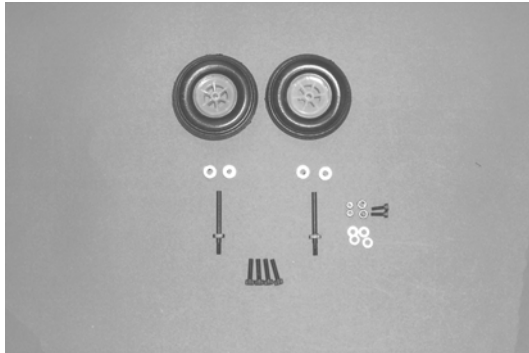

Attach the axel to the gear.



Locate the wheel pants and the two 3mm x10 mm screws and blind nuts. Using one of the screws and a washer set the blind nut into the mounting plate on the inside of the wheel pant.



Remove the 3mm screw and glue the blind nut in place with medium CA. Be careful not to get glue into the threads of the blind nut. Install one of the wheel collars on the axel on each side. Slide the wheel pant over the axel and put the wheel in place on the

inside and then install the outer wheel collar.



This is easiest done with the wheel pant flipped upside down. You can now rotate the wheel pant into position and install the 3mm screw through the landing gear to hold it in place. Use locktite on the screw.

Locate the tail wheel bracket and align it on the bottom of the fuselage with the tiller wire flush against the rear of the fuselage.

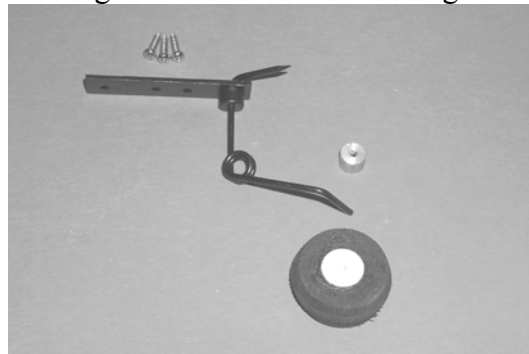

Make sure the wire is in the center of the fuselage and aligned vertically.

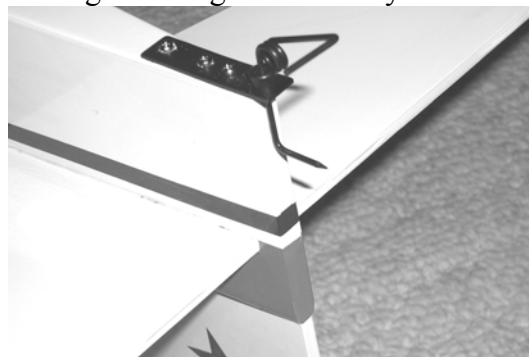

Mark the location of the three mounting holes and drill a # 55 (.052) pilot hole for

*Lanier R/c INC. P.O. Box 458 Oakwood, GA. 30566
Phone 770 532 6401 FAX. 770 532 2163*

Lanier R/c Stinger .60 ARF

the mounting screws. Mount the bracket using the three 3mmx20mm screws.

Control Horns

Locate 3 of the nylon control horns, three nylon nut plates and 6 of the 2mm screws. Locate the control horns on the bottom of the elevator as close to the inside edge as possible (stay on the flat part of the elevator, not where the corners are rounded off). Align the holes for the clevis in the control horn so they will be directly over the hinge line. Mark the location of the holes and drill a # 48 (.076) hole for the mount screws. Insert the screws through the control horn and elevator and screw into the plate on top.



Locate the rudder and remove the covering from the slot at the bottom of the leading edge where the tail wheel tiller will be installed. Place the control horn on the rudder with the center of the horn 7/8" from the bottom of the rudder and the holes for the clevis aligned over the hinge line.

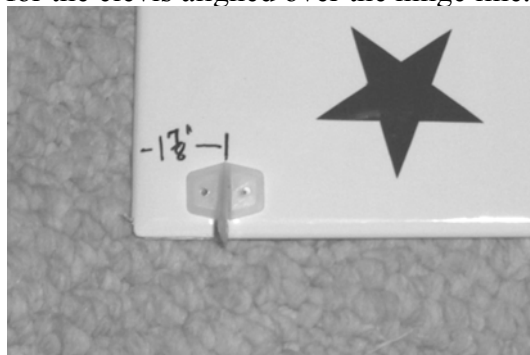

Mark the hole location and drill with the #48 drill(.076). Insert the screws and install with nut plate on opposite side.

Stab, Ailerons, and rudder hinges.

Check the hinges in the elevator, ailerons, and rudder and make sure they are approximately half way in the control surface.

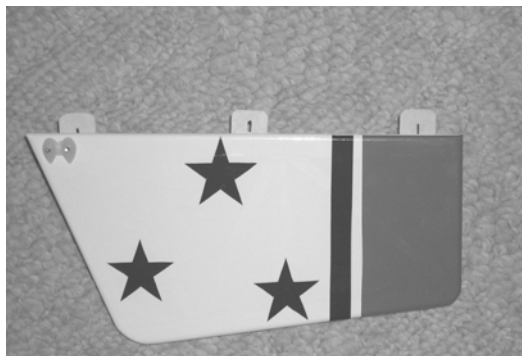

You can now install the elevator on the stab. Push the elevator against the stab and then deflect it 45 degrees down. You can now put one drop of thin CA on each hinge.



Turn the plane over and deflect the stab 45 degrees again and put one drop of CA on each hinge. Repeat for the other elevator. Use the same procedure and hinge both ailerons.

To hinge the rudder, take a strip of wax paper 1-1/2" square and slip behind the tail wheel bracket wire.

Lanier R/c Stinger .60 ARF

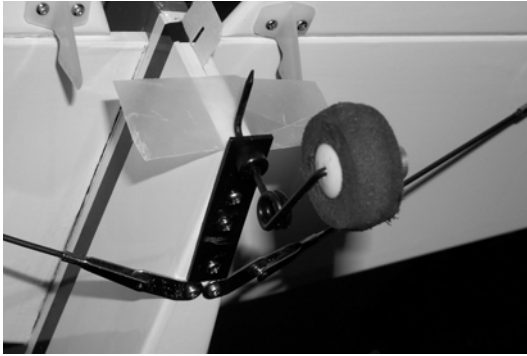

Make sure hinges are centered in the rudder and apply epoxy in the hole and slot where the rudder tiller fits. Install the rudder on the plane and deflect all the way to one side against the elevator half. Put one drop of thin CA on each hinge.

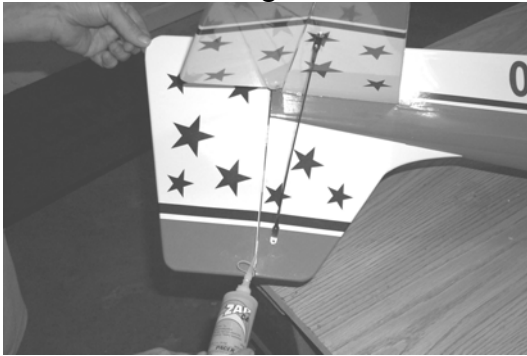

Deflect the rudder in the other direction and apply one drop of CA to the other side of all hinges. When the epoxy has cured you can remove the wax paper.

Engine Mounting

Locate the two engine mounts, four blind nuts, four 4mm x 20 bolts, four 4mm x 25mm bolts, four aircraft locknuts, and 8 flat washers.

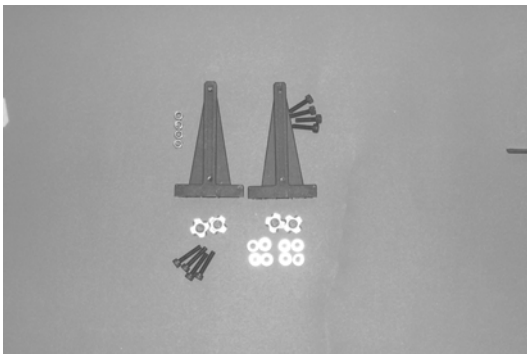

Determine where on the motor mounts your engine will fit. A four stroke will have to be mounted further out than a two stroke. Most two strokes will be approximately 4-1/2" from the firewall to the back of the prop shaft. You would not want it to be much shorter than this. The cowl will slide in and out to accommodate a large range of engine sizes. When you have determined where to mount the engine on the mounts, drill #22 (.157) holes in the mounts to match your engine.



Mount the engine to the mounts using the four 4mm x 20 mm bolts and aircraft lock nuts.

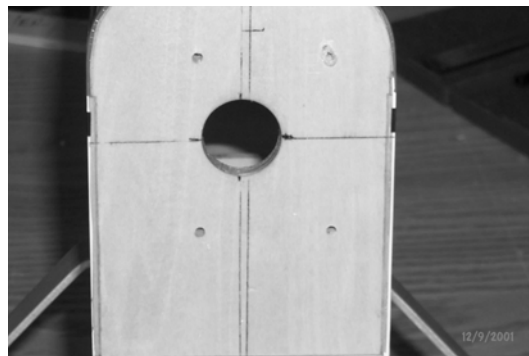

Draw a centerline on the fuselage vertically. If you are going to use right thrust, measure over 1/8" to the left side of the fuselage and draw another vertical line. Measure 3" from the bottom of the fuselage and draw a line horizontally. Center the engine up on these lines and mark for the blind nuts. Drill

Lanier R/c Stinger .60 ARF

the firewall and set the blind nuts with one of the 4mm bolts.

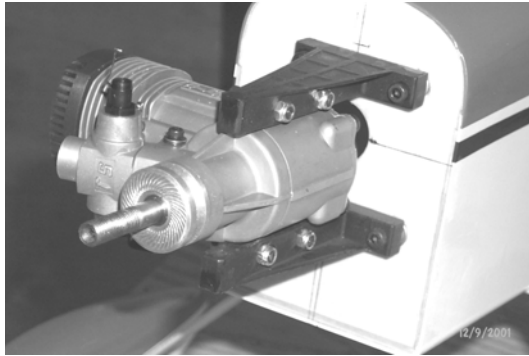

Bolt the engine in place using two washers under the left side of the motor mount for the right thrust. Use Loctite on the bolts.

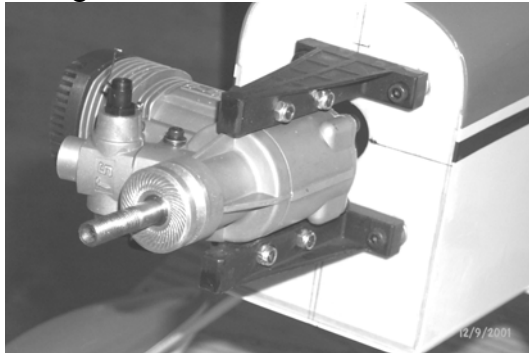

Drill a 5/32" hole in the firewall directly in line with the throttle arm on the engine. Take the 1/16" wire with the plastic sleeve and solder a clevis on the end. Insert this through the hole in the firewall and connect the clevis to the throttle arm using a piece of fuel tubing over the clevis.

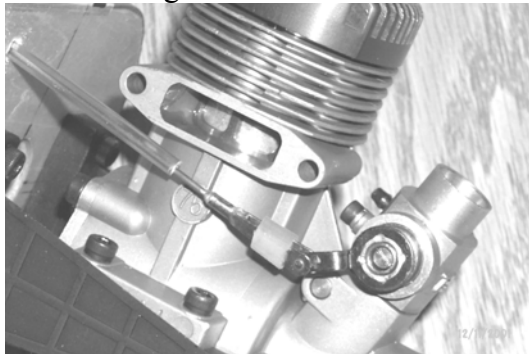

Tank assembly.

Locate the tank and its hardware.

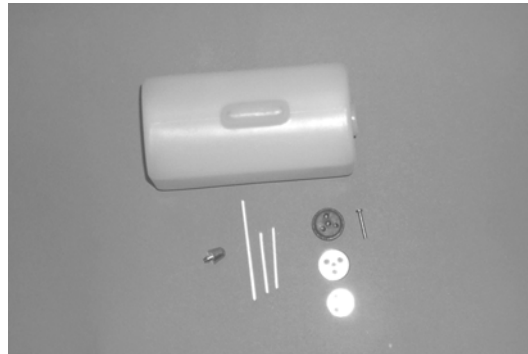

Assembly the tank stopper, with the small washer on the inside and the large one on the outside. Take the longest piece of tubing and bend it into an L shape being careful not to kink it. Keep a 1" radius in the corner. Insert it and one of the short pieces of tubing into the holes in the tank cap. Put the piece of fuel tubing on the short piece and install the clunk on the end of the tubing.

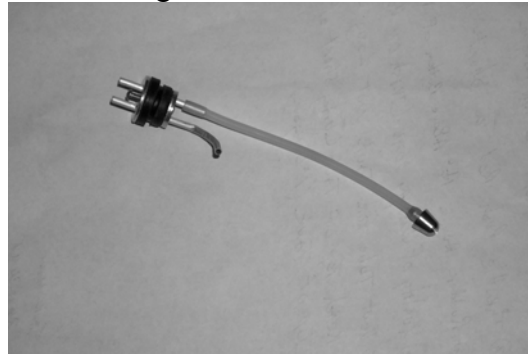

Install the assembly in the tank. The clunk on the end of the tubing should be 1/4" from the rear of the tank when held vertically. The vent tube should be turned to the top of the tank and be 1/8" off the top. When lined up properly tighten the screw.

Install the tank in the fuselage with the cap fitting in the hole in the firewall.

Lanier R/c Stinger .60 ARF

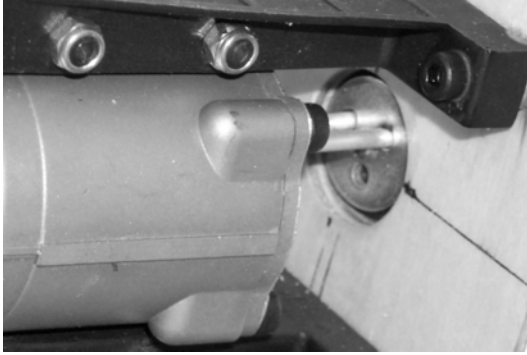

You can connect a piece of fuel tubing(not supplied) from the vent tube to the muffler and another from the pickup line to the carburetor. Using foam rubber, pad the tank on all sides inside the fuselage.



Cowl Mounting

Trial fit the cowling in place after making the cut out for the engine head and muffler.



Install the spinner back plate and align the cowl with it leaving 1/8" clearance between them. Drill a 1/8" hole in the cowl on the top center so the screw will go into the firewall. Install the 3mm screw to hold

cowl in place. Install another screw in each lower corner of the firewall on both sides of the cowl. Using the spacer blocks on each side, install another screw in the cheek cowl area.

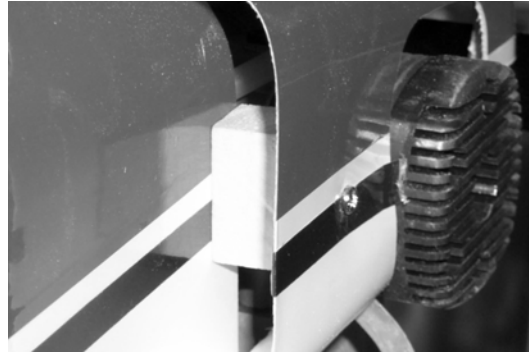

Those 5 screws will be enough to hold the cowl firmly in place.

Flying Wires

The flying wires on the tail are functional and must not be left off. Locate the four wires with clevises, the three 2mmx20mm bolts and nuts, the aluminum mounting plate and the 2mmx8mm screw.

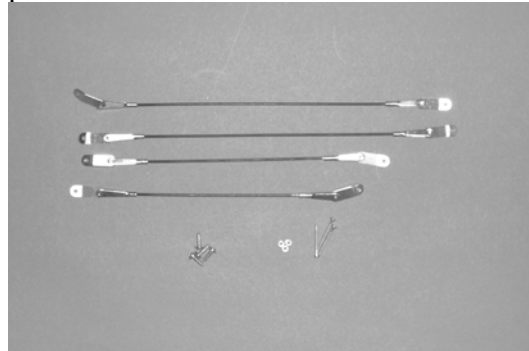

Mount the aluminum bracket on the bottom of the fuselage directly in front of the tail wheel bracket using the 2mm x 8mm screw.

Lanier R/c Stinger .60 ARF



Using the 2mm x 20mm bolts and nuts, bolt the two long flying wires to the fin in the pre drilled holes.



Insert the bolts through the tab on the other end of the wire and insert into the stab. Turn the plane over and attach the short flying wire to the bolt on the bottom side of the stab. Attach the clevis on the other end of the short flying wire to the aluminum bracket. Adjust the tension on the flying wires by removing the clevis on one end and turning. Be careful not to warp, bow, or twist the stab and fin when adjusting the tension. When adjustments are correct tighten the lock nuts in place.

Hatch Mounting

Remove the covering from the screw holes on the rear of the wing and install the 4mmx20mm bolts.

Bolt the wing in place and fit the hatch into the dowel holes in F2. Take a marking pen and mark along the sides of

the hatch from 2 to 3 inches in front of the trailing edge.

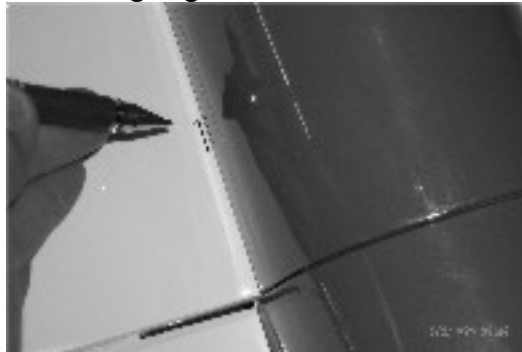

Remove the hatch and measure over 3/16" from the mark you made and make another line. Locate the 3/8"x 11/16"x 1" hardwood blocks and position them on the inside mark at the front edge of the bolt reinforcement plate.



Mark around the block then remove the covering where they will glue down. Use epoxy and glue in place. Use a small piece of tri stock(3/8"x1") on the back side to reinforce the part. Remove the covering under it and epoxy in place.

Mark the location of the block on the hatch cover.

Lanier R/c INC. P.O. Box 458 Oakwood, GA. 30566
Phone 770 532 6401 FAX. 770 532 2163

Lanier R/c Stinger .60 ARF



Measure up from the bottom edge of the hatch 3/8" and make a mark. Fit the hatch in place and drill a 3/32" hole on this mark into the block inside. remove the hatch and open the hole on the hatch up to 9/64". Put the hatch back in place and install a #6x3/4" sheet metal screw with a washer to hold the hatch in place. Repeat for the other side.

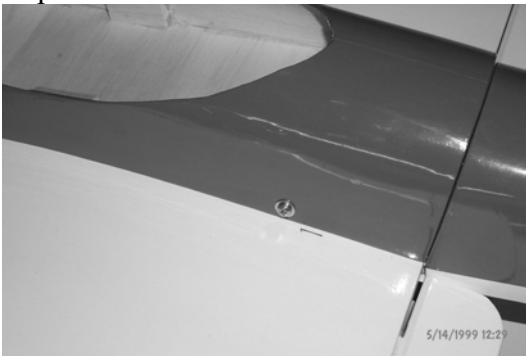

Finish the interior of the cockpit with pilot and instrument panel if desired(not included). Cut the clear canopy to the scribe line and apply a bead of canopy glue around the inside edge about 1/4" wide.

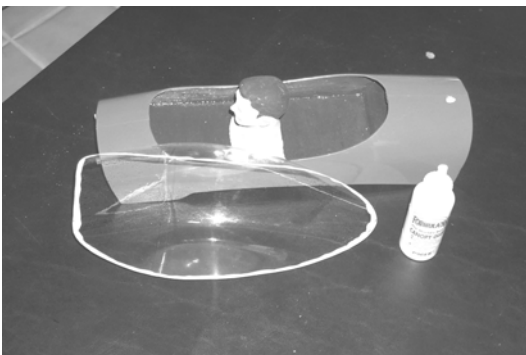

Carefully put the canopy in place and use masking tape to hold down till the

glue has dried. The ZAP canopy glue can be cleaned up with water while wet and will dry clear.

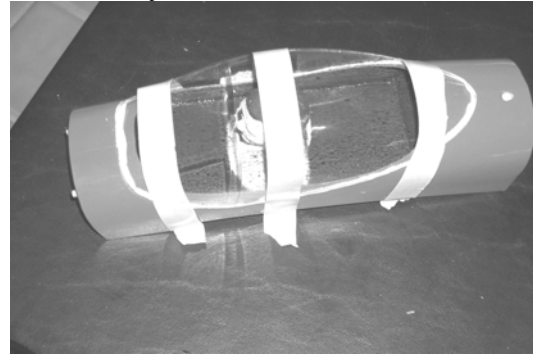

Installing Radio

Locate the two wooden pushrod and the five 2mm rods threaded on one end. Take two of the treaded rods and bend 90 degrees at 7-1/4" and cut the bent end at 1/8" long.



Locate the wooden dowel with two holes in one end.

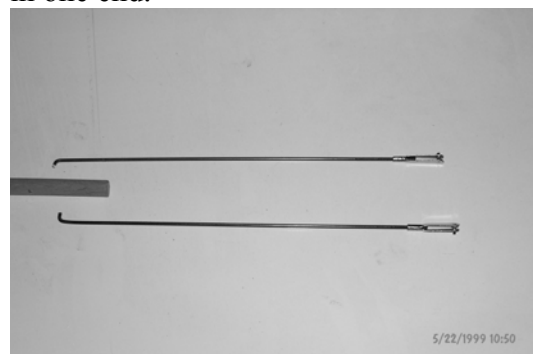

Insert the 1/8" end into the holes, wrap with thread, and glue with thin CA.

Lanier R/c INC. P.O. Box 458 Oakwood, GA. 30566
Phone 770 532 6401 FAX. 770 532 2163

Lanier R/c Stinger .60 ARF

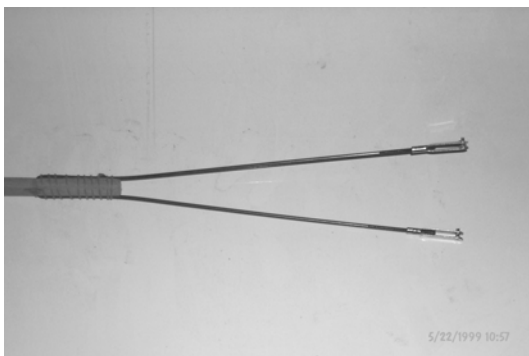

Bend the wire at the end of the wooden push rod out on each side 1-1/4" so the two clevises are 2-1/2" inches apart.



Take the piece of wire you cut off and bend the end at 1/4". Insert this into the other end of the pushrod and wrap and glue it. This completes the elevator push rod.

Now take another 2mm wire and clevis and cut it at 7-1/2", bend a 1/4" leg on the opposite end from the clevis and attach it to the other wooded dowel.



Use the piece of wire you cut off, bend a 1/4" leg in it and attach to the other end of the wooded pushrod. This completes the rudder pushrod.

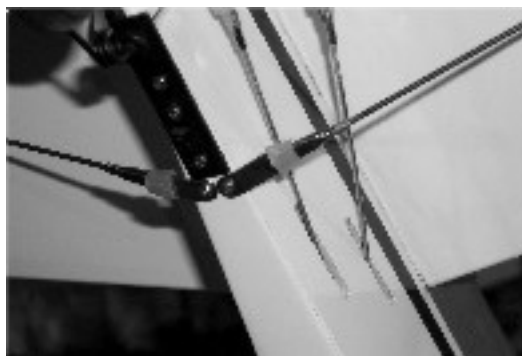

Locate the pushrod exits in the fuselage at the rear. With a sharp knife remove the covering from the slot of both the upper slots for the elevators and the one lower slot on the right side for the rudder. Insert the pushrod through the holes and install the clevises and keepers.

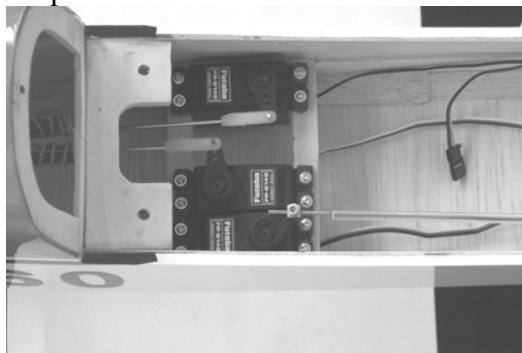

Install the servos in the tray with the elevator servo all the way against the left side with the arm turned forward and the throttle servo against the right side with the arm turned forward. Mount the rudder servo against the throttle servo with the arm turned to the rear. Install servo arms, center them up with the radio on, and bend the end of the pushrod up at 90 degrees with the bend over the center of the hole. Cut the end off leaving 1/4" and install the swing in nylon keeper. Do this for the rudder and elevator. Install the e-z connector on the throttle arm and install the throttle pushrod with the nylon sleeve. You will

Lanier R/C Stinger .60 ARF

need to drill a hole in the firewall in line with the throttle area.

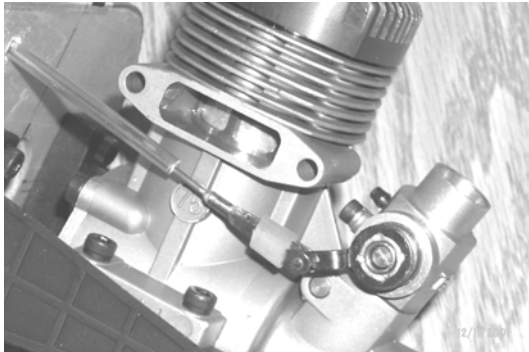

Install a clevis on the end and solder it in place. Connect to throttle arm and install fuel tubing keeper.

Install the aileron servos using extensions to get the wires out the center of the wing.

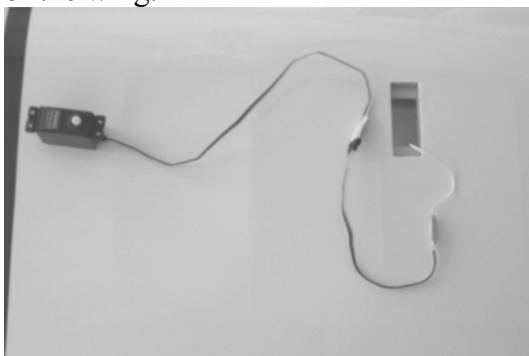

There is a string installed in the servo cavity to use to pull the wire through the hole. Install the servo arm and mark the location of the control horn on the aileron straight back from the hole in the servo horn so the pushrod will be perpendicular to the hinge line.



Install the control horn using the two screws and the nylon plate on top. Take the aileron control rod with clevises on both ends and attach to the control horn.



With the arm centered with the radio on install on servo arm. Adjust rod with clevises till aileron is level and tighten the jam nuts. Put a drop of locktite on the nuts. Do this to the other aileron being sure to put both pushrods on the outboard side of the servo.

Install the switch on the left side of the plane just in front of the servo tray. Wrap the receiver and battery pack in foam and install in the opening between the tank and servo tray.

Getting your model ready to fly.

Assemble the plane using the two 4mm x20mm bolts on the wing. Install the cockpit cover and accurately mark the balance point on the bottom of the wing, on both sides, next to the fuselage. The CG should be between 4" and 4-1/2" behind the leading edge. All components should be in the model and it should be ready to fly when balancing, the fuel tank should be empty. Pick the model up on the CG marks and it should hang nose down about 10 degrees.

The control throws on low rate should be 3/8" up and down on the ailerons, 3/4" up and down on the elevators, and 3" left and right on the rudder.

Lanier R/C INC. P.O. Box 458 Oakwood, GA. 30566
Phone 770 532 6401 FAX. 770 532 2163

Lanier R/c Stinger .60 ARF

Double check all servos and make sure the servo arms are secure and that all clevis are secured with a retainer.

Make sure the control surfaces move in the proper direction and the throttle is not reversed.

We hope you enjoy your Stinger 60.

Thanks

Parts list

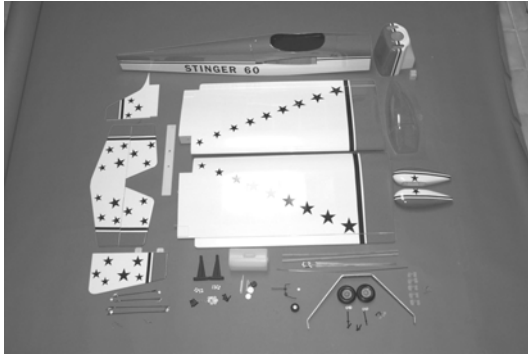

Fuselage
Left wing panel
Right wing panel
Dihedral brace
Stab
Left elevator
Right elevator
Fin
Rudder
Left wheel pant
Right wheel pant
Cowl
Cowl mount blocks
Wing cover
Wing cover mount blocks
Clear canopy

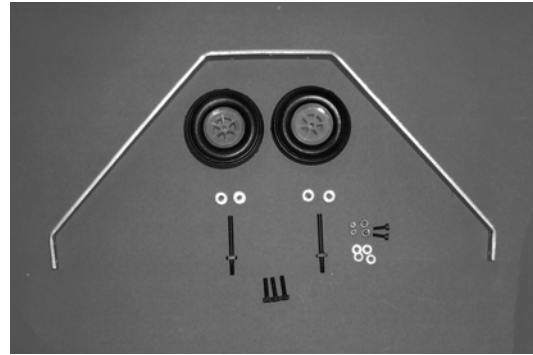

Landing gear
Two wheels
Two axels with nuts
Three 4mm bolts
Two 3mm bolts with washers and blind nuts
Four Wheel collars

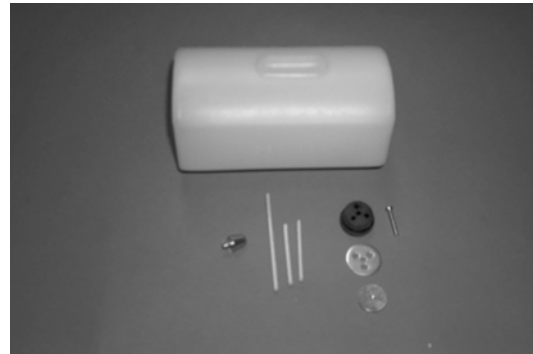

Fuel tank
Rubber stopper
Front and rear washer with screw
Klunk
Aluminum tubes (3)

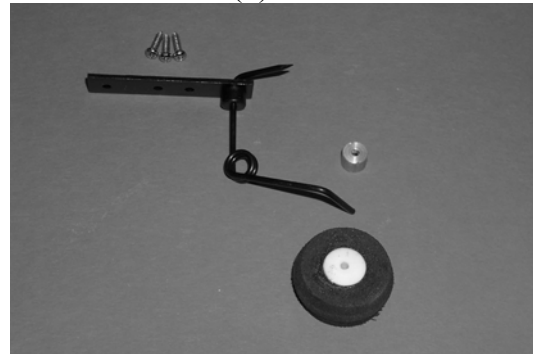

Tail wheel bracket
Tail wheel
Wheel collar

Lanier R/C INC. P.O. Box 458 Oakwood, GA. 30566
Phone 770 532 6401 FAX. 770 532 2163

Lanier R/c Stinger .60 ARF

Two 3mm screws

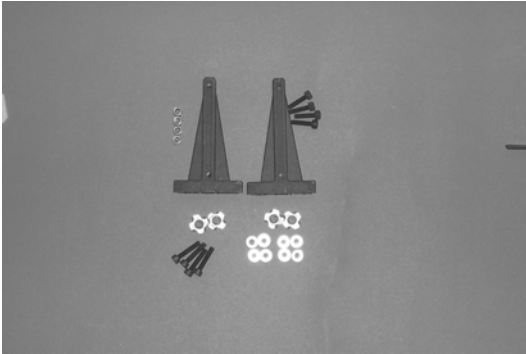

Two motor mounts
Four 4mmx20mm screws
Four 4mmx15mm screws
Four blind nuts
Eight washers

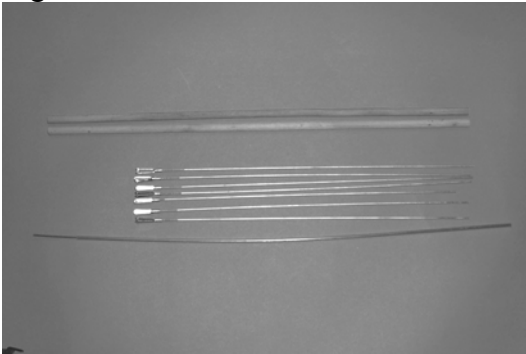

Two wooden pushrods for rudder and elevators
Five 2mmx12" threaded rods
One throttle rod 1/16"x17-1/2"
One plastic tube for throttle rod



Two aileron pushrods with clevis



Two long flying wires with hardware
Two short flying wires with hardware
Three 2mmx 17mm bolts
Three 2mm nuts
One aluminum bracket
One 3mm screw

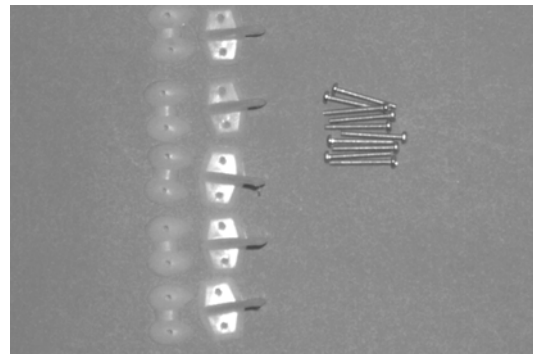

Five nylon control horns with plates
Ten 2mm x17mm screws

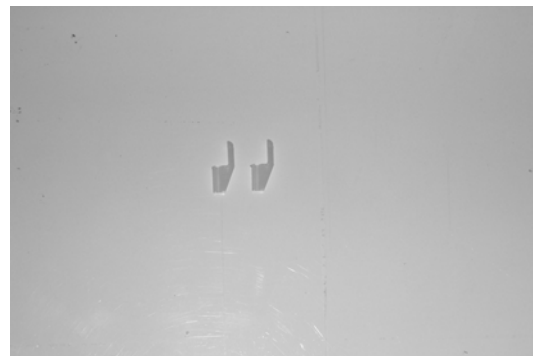

Two nylon swing in keepers

*Lanier R/c INC. P.O. Box 458 Oakwood, GA. 30566
Phone 770 532 6401 FAX. 770 532 2163*

Lanier R/C Stinger .60 ARF

Additional Equipment needed to complete your Stinger .60.

.61 to .90 2-Stroke or 4-stroke engine
Propeller for your engine.
Four channel radio with 5 servos.
Two 12 inch servo extension leads
Fuel line.
2-1/2" spinner

Adhesives

Thin CA (cyanoacrylate) glue
Medium CA (cyanoacrylate) glue
30 minute epoxy
Z-42 threadlock
Zap canopy glue