

**Futaba****R304SB**

T-FHSS-2.4GHz System  
S.BUS2, 4-Channel  
Receiver for Model Car



### ⚠ WARNING

⊘ **NEVER** use dry batteries for the power supply of the **R304SB** as this may cause difficulties with the receiver's operation.

❗ Wrap the receiver with something soft, such as foam rubber, to avoid vibration. Do not splash water over the receiver.

❗ Since the receiver generates a certain amount of heat, install the place with good ventilation.

Thank you for purchasing the **R304SB** receiver. The **R304SB** is designed for use with the Futaba **T-FHSS** system transmitter.

The **R304SB** receiver has adopted the newly developed bidirectional communication system "T-FHSS".

#### •Telemetry system

With the **telemetry system**, the running status can be displayed at the transmitter. The telemetry data can be checked at the transmitter by connecting the **telemetry sensor** sold separately to the **S.BUS2** connector of the **R304SB** receiver.

#### •Normal mode/High Speed mode

The "Normal mode" accepts any type of servos or the peripheral. The "High Speed mode" only accepts the digital servos, including BLS series, and most peripheral equipments such as the brushless ESCs. Please pay special attention to the information contained within this manual and transmitter's manual in order to have a pleasant running experience.

## Link Procedure

Each transmitter has an individually assigned, unique ID code. In order to start operation, the receiver must be linked with the ID code of the transmitter with which it is being paired. Once the link is made, the ID code is stored in the receiver and no further linking is necessary unless the receiver is to be used with another transmitter.

- 1 Place the transmitter and the receiver close to each other within half (0.5) meter.
- 2 Place the transmitter into the linking mode, and turn on the receiver.
- 3 During countdown, push the receiver tact switch for approximately 2 seconds. The LED will begin to blink red. After the receiver LED switches from blinking red to green → red steady light, If the transmitter and receiver are linked normally, set the power switch to the OFF position and then return it to the PWR ON position. If the receiver LED lights green, linking was successful. Actually check servo operation.

\*Please refer to the table below for LED status and receiver condition.

No signal reception	LED: Red
Receiving signals	LED: Green
Unrecoverable failure (EEPROM, etc.)	LED: Red and Green turn on alternately

\*Refer to the transmitters operation manual for complete details on how to place the transmitter into the linking mode.

\*If there are many T-FHSS systems turned on in close proximity, your receiver might have difficulty establishing a link to your transmitter. This is a rare occurrence. However, should another T-FHSS transmitter/receiver be linking at the same time, your receiver could link to the wrong transmitter. This is very dangerous if you do not notice this situation. In order to avoid the problem, we strongly recommend you to double check whether your receiver is really under control by your transmitter.

**Note: The R304SB is compatible with the T-FHSS system transmitters.**

**The receiver type setting of the transmitter is set in T-FHSS.**

\*Futaba T-FHSS system does not work with current Futaba S-FHSS/FHSS/FASST-est/FASST system.

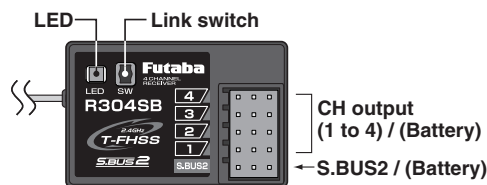

#### Operating Precautions:

Once the **R304SB** detects the **T-FHSS normal mode** or **T-FHSS high speed mode**, the detected mode is locked as long as the power is ON. When need to change the mode, please cycle power.

## Usage condition on "High Speed mode"

### ⚠ CAUTION

❗ When using the high-speed mode, use a Futaba digital servo (including brushless servo). Analog servos cannot be used.

•The use of analog servos may cause servo trouble.

### ⚠ WARNING

❗ After the linking is done, please cycle receiver power and check if the receiver to be linked is really under the control by the transmitter to be linked.

⊘ Do not perform the linking procedure with motor's main wire connected or with the engine operating as it may result in serious injury.

## The Example of Connection

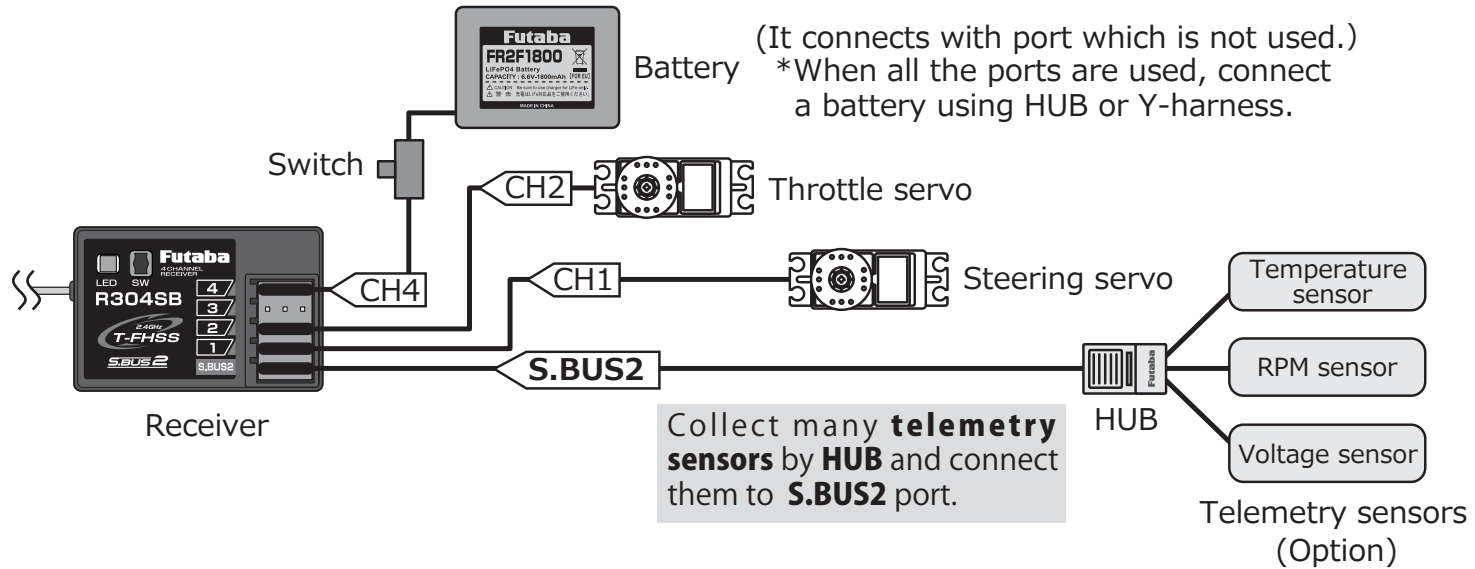

### Compliance Information Statement (for U.S.A.)

This device, trade name Futaba Corporation of America, model number R304SB, complies with part15 of the FCC Rules. Operation is subject to the following two conditions:

- (1) This device may not cause harmful interference, and
- (2) This device must accept any interference received, including interference that may cause undesired operation.
- (3) This module meets the requirements for a mobile device that may be used at separation distances of more than 20cm from human body.

To meet the RF exposure requirements of the FCC this device shall not be co-located with another transmitting device.

The responsible party of this device compliance is:

Futaba Service Center

3002 N Apollo Drive Suite 1, Champaign, IL 61822 U.S.A.

TEL (217)398-8970 or E-mail: support@futaba-rc.com (Support)

### R304SB Specifications:

(T-FHSS system, S.BUS2, 4-channel receiver)

- Receiving on 2.4GHz band
- System: T-FHSS system  
At Normal/High speed mode (auto detection)
- Power requirement Rated voltage: 4.8V-7.4V / Usable voltage: 3.5-8.4V
- F/S and Battery F/S function: It is set according to the transmitter used.
- Battery F/S voltage: Set it with the transmitter arbitrarily.
- Size: 1.38x0.91x0.33" (35.1x23.2x8.5mm)
- Weight: 0.23oz. (6.6g)

FUTABA CORPORATION

1080 Yabutsuka, Chosei-mura, Chosei-gun, Chiba-ken, 299-4395, Japan

Phone: +81 475 32 6982, Facsimile: +81 475 32 6983

©FUTABA CORPORATION 2013, 4 (1)