



# Futaba

DIGITAL PROPORTIONAL  
RADIO CONTROL

**PCM**  
PULSE CODE MODULATION SYSTEM

## INSTRUCTION MANUAL

**FP-8SGAP**  
PCM 8 CHANNELS,  
FOR F3A AIRCRAFT



FUTABA CORPORATION OF AMERICA  
FUTABA CORPORATION

***Thank you for purchasing a Futaba  
digital proportional radio control set.  
Please read this manual carefully before using your set.***

## TABLE OF CONTENTS

### GENERAL INFORMATION

Features	2-3
Contents and Ratings	4
Glossary of Terms	5-6
Basic Transmitter Controls	6-9
Batteries and Charging Instructions	10
Tachometer/Timer Operation	11-13
Receiver and Servos	14
FP S130 and FP-S130G Exploded Views	15
Splined Horns	16

### ADJUSTMENTS AND FLIGHT TECHNIQUES

Basic Linkages and Installation	17
Using ATV (Adjustable Travel Volume)	18-19
2ND ATV (Conventional)	20
Servo Reversing Switches	20
Using Dual Rate (Aileron, Elevator, and Rudder)	21
Rudder Auto Dual Rate	22
Using VTR (Variable Trace Ratio)	22
Suggestions on ATV, D/R, and VTR	23
Using ATL (Adjustable Throttle Limit)	24
FS (Fail Safe) and HOLD Functions	25
BFS (Battery Fail Safe) and BFS Memory	25
Servo Test Functions	26
Aircraft with Variable Pitch Prop	27-28
Throttle Position Trimmer	28
Aircraft with Flaps	29
Elevator/Flap Mixing	30
Flap/Elevator Mixing (Pre-Set Flaps and Elev. Trim)	30
Aircraft with Flaps and Spoilers (Airbrake)	31
Flap Trim Function	31
Snap Roll Switch	32
Programmable Mixing and Examples	32-33
Mutual (Bi-directional) Mixing (FLPRON, ELEVN, V TAIL, DIFF)	34-35

## INDEX FOR TRIMMER PANEL FUNCTIONS

Switch or Trimmer Number	Description	Ref. Page
1	Aileron Dual Rate 1 Trimmer	31
2	Aileron Dual Rate 2 Trimmer	31
3	Aileron Linear/VTR Safety Switch	31
4	Throttle Delay Trimmer	27, 28
5	Pitch Delay Trimmer	27, 28
6	Throttle/Pitch Mixing Trimmer	27, 28
7	Throttle/Pitch Mixing Safety Switch	27, 28
8	Throttle Position Trimmer	27, 28
9	Elevator Flap Mixing Trimmer	30
10	Elevator Flap Mixing Safety Switch	30
11 & 12	Programmable Mixing Rate Trimmers	32, 33
13	Slave Channel Mixing Board	32, 33
14	Master Channel Mixing Board	32, 33
15	Aileron Differential Trimmer	34-35
16	ELEVN/V. Tail Mixing Switch	35-36
17	FLPRON/DIFF Mixing Switch	34-35
18	Flap Switch	31
19	Airbrake Elevator Trimmer	30
20	Airbrake Flap Trimmer	31
21	Rudder Dual Rate Trimmer	21
22	Rudder Linear/VTR Safety Switch	21
23	Elevator Dual Rate Trimmer	21
24	Elevator Linear/VTR Safety Switch	21
25-28	Snap Roll Timer Setting Trimmers (Optional)	32
29	Snap Roll Safety Switch	32
30	Switch 16 Function Select Switch	32
31	Automatic Dual Rate Rudder Safety Switch	21
32	Flap, Spoiler Elevator Mixing Switch	30
33	Throttle Flap, Spoiler Elevator Mixing Switch	31
34-35	Aileron 2ND ATV Trimmers	20
36-37	Elevator 2ND ATV Trimmer	20
38-45	Servo Reversing Switches	20
46-47	ATV/FS Buttons	18, 24-25
48	Channel Select Switch	19, 24-25
49	Function Select Switch	19, 24-25

### NOTE:

Please read and follow instructions for installation and usage in their entirety and follow carefully. Failure to follow instructions could result in serious property damage and/or personal injury. This system is intended for use by experienced R/C hobbyists. Beginners should seek expert advice and Assistance before operating this system.

## •FEATURES

The FP-8SGAP was specially developed to use PCM (pulse code modulation) for FAI RC aerobatics F3A aircraft. It is an extremely noise and dead-point resistant digital proportional RC set with a microprocessor in the transmitter and the receiver. Please read this manual before using your set.

### TRANSMITTER FP-T8SGAP

- RF module system. The frequency band can be changed with one touch.
- DSC (Direct Servo Controller) allows operation of the servos without turning on the transmitter. Wire operation is possible by using the special cord supplied (FSC.1)
- Servo reversing switch for all channels allows reversing of the servos with the flip of a switch.
- Dual rate or non-linear VTR (variable trace ratio) aileron, elevator, and rudder. Two-stage dual rate on aileron.
- Rudder auto dual rate. Rudder dual rate is turned on and off automatically with operation of the throttle stick.
- Newly designed slantable open gimbal sticks provide maximum operation feel. Stick angle and spring strength can be adjusted.
- Non-slip adjustable lever head. The stick length can be adjusted by turning the knob head.
- New throttle -> pitch control mixing is perfect for variable pitch propeller which maximizes engine power and propeller efficiency.
- Mutual mixing function allows aileron + elevator, aileron + flaps, and aileron + rudder mixing and aileron differential operation.
- Elevator -> flap mixing is especially advantageous in circle aerobatics.
- Flap, spoiler -> elevator mixing allows control of the aircraft attitude while using the air brake (flap, spoiler).
- Throttle -> (flap, spoiler) -> elevator mixing allows enhancement of the air braking effect by throttle stick operation when diving and landing.
- Programmable mixing function permits mixing with the desired channel.
- Four-function snap roll switch (timer is optional)
- Idle-up lever, the engine idling speed can be independently adjusted during throttle -> pitch control mixing.
- New single-chip microprocessor allows one-touch fail safe setting and introduction of an automatic transmission system which eliminates the need for fail safe setting at the beginning of each flight and improves safety.
- Pitch control lever. HIGH side pitch of variable pitch propeller can be adjusted during throttle -> pitch control mixing.
- New ATV (Adjustable Travel Volume) on all channels allows independent adjustment of servo left, right, up, and down throw.
- Second ATV. Besides new pushbutton ATV on aileron and elevator, conventional trimmer ATV is also installed.
- Monitor lamp comes on when throttle -> flap, spoiler -> elevator mixing or throttle -> pitch control mixing and flap, spoiler -> elevator mixing and snap roll are set and goes out when they are in use.
- Fail-safe switch (function OFF switch) is provided for each function so that only the desired functions need be turned on.
- Throttle ATL (Adjustable Throttle Limiter) makes throttle linkage simple and positive.
- Two servo test functions. A slow sweep to check neutral characteristic, trackability cycle servo to test servo operation.
- Tachometer/timer with built-in tachometer, up timer, down timer, integrating timers, and battery alarm functions.
- Built-in power error back-up circuit. When the internal Nicd battery approaches the fully discharged state, an LED flashes to indicate that the memories presetted (memory, ATV, FS, etc.) are gone. Please charge battery and set all memory functions again.
- Highest quality extruded aluminum case. Sophisticated transmitter design gives easy fitness and comfortable feeling to your hands.
- Neck strap supplied as a standard accessory. The numerous functions of the transmitter can be easily performed by supporting the transmitter from your neck.

## RECEIVER FP-R118GP

- The receiver of this set is a miniature PCM receiver in which the highest reliability has been pursued. It is the first R/C receiver in the world to incorporate the newest computer technology.
- Miniature PCM receiver with high speed single microprocessor. Resistance to adjacent band and spark noise interference has been increased by one full order of magnitude.
- Microprocessor servo hold function eliminates erroneous operation when a "dead point" area is entered.
- Microprocessor provides fail safe and battery fail safe functions for greater safety.
- Error lamp display allows checking of the receiver operating state.
- DC-DC converter in the power supply improves low-voltage operation characteristics.
- High sensitivity design with RF amplifier.
- Ultra narrow-band ceramic filter and PCM system are invulnerable to adjacent band interference.
- Gold plated connector pins eliminate poor contact. Polarized housing improves reliability against shock and vibration.
- DSC circuit. Each servo can be controlled from the transmitter without turning on the transmitter by connecting the transmitter directly to the C terminal.

## SERVO FP-S130

- Small, double ball bearing, water-tight & dust-tight servo. High output torque 55.6 oz-in (5kg-cm), high-speed .24sec/60 .
- New indirect drive potentiometer improves vibration and shock resistance and neutral precision.
- Futaba low-power custom 1C provides high starting torque, narrow dead band, and excellent trackability.
- Fiberglass reinforced PBT (polybutylene terephthalate) molded servo case is mechanically strong and invulnerable to glow fuel.
- Strong polyacetal resin ultra-precision servo gear features smooth operation, positive neutral, and very little backlash.
- Fiberglass reinforced epoxy resin PC board with thru-the-hole plating improves servo amp vibration and shock resistance.
- Thick gold plated connector pins ensure positive contact and improve reliability against shock and vibration. The connector housing is polarized to prevent reverse insertion.
- Six special adjustable splined horns.

## SERVO FP-S130G

- Small retractable landing gear servo with high class 5-pole micromotor. High output torque 4.7kg-cm, high-speed 0.34sec/60°, waterproof type.
- Since forward/reverse operation is controlled by the pulse width of the signal generated by turning the transmitter snap switch on and off, the motor stops at the end of its throw in either direction.
- Unlike other proportional servos, motor drive current does not flow when the servo is stopped even if a load is applied. Thus current drain is extremely low.
- Fiberglass reinforced PBT (polybutylene terephthalate) injection molded servo case is mechanically strong and invulnerable to glow fuel.
- Strong polyacetal resin ultra-precision servo gear features smooth operation, positive neutral, and very little backlash.
- Fiberglass reinforced epoxy resin PC board with thru-the-hole plating improves servo amp vibration and shock resistance.
- Thick gold plated connector pins ensure positive contact and improve reliability against shock and vibration. The connector housing is polarized to prevent reverse insertion.

# ●CONTENTS AND RATINGS

Ratings and specifications are subject to change without prior notice.

Model	FP-8SGAP
Transmitter	FP-T8SGAP x 1 with module FP-TF-FM
Receiver	FP-R118GPx 1
Servos	FP-S130x4
Switch	SWH-5x 1 (R4-SWJx 1)
Nicd battery	NR-4J x 1
Accessories	Battery charger, landing gear adaptor, DSC cord, CHG adaptor, DSC-CHG cord, servo tray, frequency flag, spare horn, neck strap, screws

## Transmitter FP-T8SGAP

**Operating system** : Two-stick, 8 channels for F3A pattern

**Transmitting frequency** : 50/53MHz BANDS } Chosen band  
72/75MHz BANDS }  
53MHz ↔ 72MHz  
Frequency change to any of above bands is possible by merely changing RF module.

**Modulation** : PCM, FM

**Power requirement** : 9.6V 8/500mA internal Nicd battery

**Current drain** : 250mA

## Receiver FP-R118GP

**Receiving frequency** 50/53MHz BANDS Chosen  
72/75MHz BANDS band  
455kHz

**Intermediate frequency** 455kHz

**Power requirement** 4.8V Nicd battery (shared with servo)

**Current drain** 42mA (4.8V reception)

**Dimensions** 2.23 x 1.65x0.94 in  
(57 x 52 x 24mm)

**Weight** 1.85oz (53g)

**Receiving range** 500m on the ground  
1000m in the air  
When FP-T8SGAP used.  
(At the best radio wave condition of environment)

## Servo FP-S130

**Control system** +pulse width control, 1520  $\mu$ S.N

**Operating angle** One side 45° or greater (including trim)

**Power requirement** 4.8V (shared with receiver)

**Current drain** 5mA (at idle)

**Output torque** 55.6oz.in (4kg-cm)

**Operating speed** 0.24 sec/60°

**Dimensions** 1.52x0.77 x 1.36 in  
(38.5 x 19.5x34.5mm)

**Weight** 1.47oz (42g)

## Landing Gear Servo FP-S130G (Option)

**Control system** +pulse width control

**Operating angle** Rotary approx 160°

**Power requirement** 4.8V (shared with receiver)

**Current drain** 8mA (at idle)

**Output torque** 65.3oz.in (4.7kg-cm)

**Operating speed** 0.34 sec/60°

**Dimensions** 1.52 x 0.77 x 1.36 in  
(38.5 x 19.5 x 34.5mm)

**Weight** 1.48oz (42g)

## Battery Charger FBC-8B(2)

**Input voltage** : 120 VAC, 50/60 Hz

**Output** : TX side 9.6V/45mA  
RX side 4.8V/45mA

## Receiver Servo Nicd Battery NR-4J

**Voltage** : 4.8V, 4/500mA

**Dimensions** : 2.01 x 2.28 x 0.59 in  
(51 x 58 x 15mm)

**Weight** : 3.35oz (95g)

# •GLOSSARY OF TERMS

NOTE: Please take the time to familiarize yourself with the terms and abbreviations below. They will be used throughout the instructions and are important in understanding the operation and potential of your system.

## PCM (Pulse Code Modulation)

Pulse Code Modulation utilizes a precise digital code to convey information from the transmitter encoder to the receiver. This state of the art method makes many of the sophisticated functions of the FP-8SGAP possible, as well as providing far superior immunity to noise and interference than is possible with conventional encoding methods.

## ATV (Adjustable Travel Volume)

This feature allows independent adjustment of servo travel in each direction. ATV is sometimes referred to as "endpoint adjustment". Two different types of ATV are standard with this system, (1) Pushbutton or Programmed (Memory) ATV and (2) 2nd ATV (Conventional).

## MEMORY ATV

This type is available on all eight channels. These adjustments are stored in the transmitter memory circuit and are retained when the power switch is turned OFF. They are lost however, if the transmitter Nicd batteries reach full discharge.

## 2ND ATV

Available on Aileron (CH 1) and Elevator (CH 2). This is the conventional type ATV which is set by using trimmer pots on the transmitter back panel. These settings are NOT affected if the transmitter batteries are discharged.

## DUAL RATE

Rate switches allow the pilot to select different servo travel limits (for varying control sensitivity) in flight. Servo travel is affected equally in both directions from center.

## SAFETY (ACT/INHIB) SWITCHES

These switches, located on the transmitter trimmer panel allow mixing and certain other functions to be deactivated when not desired. When the Safety Switches are set to the INHIB position, the function will remain OFF even if the transmitter control switch is set to ON.

## VTR (VARIABLE TRACE RATIO)

This is a special type of non-linear control response. When VTR is used, servo travel is normal and linear up to about 80 percent of the transmitter control stick movement where the servo travel is abruptly increased to a higher rate (both rates adjustable). This allows a normal feel for most flying with extra movement available for emergencies and certain aerobatic maneuvers. Another way to think of this function is as "automatic Dual Rate".

## SERVO REVERSING

This function allows the modeler to reverse the direction of servo movement (in relation to control stick movement) for various installation requirements. This can be done by conveniently flipping a switch on the trimmer panel. Servo travel and neutral position are not affected.

## BFS (Battery Fail Safe)

This function provides a warning to the flyer when airborne battery voltage reaches a critically low level by moving the throttle servo to medium slow or slow position.

## ATL (Adjustable Throttle Limit)

This feature makes adjusting the throttle linkage much easier. The throttle trim lever affects only the LOW or IDLE position and not the HIGH throttle servo position. Therefore, the linkage can be set for proper opening at high throttle and the trim lever used to set the proper idle speed without changing the maximum opening.

## MIXING

In general, mixing functions allow two or more different channels to be operated by moving a single transmitter control. Many useful and versatile functions are made possible in this manner. Three types of mixing functions are provided.

(1) Unidirectional mixing — This function allows one or more channels to be "slaved" to a "master" channel. Movement of the master channel control causes movement of both master and slaved servos simultaneously. Operation of the slave channel control however, does not cause movement of the master channel servo. An example is Aileron/Rudder mixing (see page 33) where the Rudder is slaved to Ailerons for coordinated turns.

(2) Mutual (Bi-Directional) Mixing — With this type of mixing, two channels are mixed so that operation of the control for either channel causes movement of both servos. This is useful in providing sophisticated functions such as V-tail operation, flaprons, and elevons on tailless designs.

(3) Switch-Activated Mixing — Two or more channels can be programmed so that the servos involved move to a preset position when a transmitter control switch is pulled or button pushed. Snap roll switches, roll buttons, and pre-set flap switches are examples of this type of mixing.

### PROGRAMMED MIXING

Unidirectional mixing of any two channels desired is possible using the pin board and jumper connectors on the transmitter back panel. Either channel may be designated as "master" or "slave"

### DSC (Direct Servo Control)

Operation of the entire system with the transmitter switch in OFF position is possible using the DSC cord. This is useful for checking and adjusting control movements on the ground while someone else is flying on your frequency.

### FAIL SAFE

The Fail Safe function moves servos to a pre-set position if the transmitter signal is lost or interrupted by strong interference. The servos will be held in the pre-set position until a proper signal is again received at which time Fail Safe is released.

### HOLD

The Hold function holds servos at the same position as immediately prior to signal interruption. Hold is released when a proper signal is resumed.

---

## •BASIC TRANSMITTER CONTROLS

The servo reversing switches are assumed to be in the normal position in the descriptions in this section. When the reversing switches are in the reverse position, servo operation is the opposite of that described here.

6

- 1 Aileron stick Controls the ailerons.
- 2 Elevator stick Controls the elevators.
- 3 Throttle stick Controls the throttle.
- 4 Rudder stick Controls the rudder.
- 5 Landing gear switch Controls the landing gear.
- 6 Flap and flap trim control (CH6) knob
- 7 Spoiler (CH7) control knob
- 8 Pitch control (CH8) lever and pitch control HIGH side trimmer
- 9 Idle-up lever
- 10 Flap, spoiler -> elevator (6, 7 -> 2) mixing ON-OFF switch
- 11 Throttle -> (flap, spoiler) -> elevator (3 -> 6, 7 -> 2) mixing / Throttle -> pitch control mixing ON-OFF switch
- 12 Elevator -> flap (2 -> 6) mixing ON-OFF switch
- 13 Snap Roll ON-OFF switch (self off)
- 14 Aileron dual rate switch (2-stage)
- 15 Elevator dual rate switch
- 16 Rudder dual rate/Programmable mixing ON-OFF switch
- 17 Aileron trim lever
- 18 Elevator trim lever

19 Throttle trim lever with ATL

20 Rudder trim lever

21 Tachometer/timer

The tachometer/timer has the following functions:

#### 7. TACHOMETER

- Measurement by external sensor.
- Two blade propeller specifications:

LOW range	100 to 30,000 rpm
	Error 100 rpm
HIGH range	100 to 60,000 rpm
	Error 200 rpm

#### 2. UP TIMER

- 0 to 60 minutes with seconds display.

#### 3. DOWN TIMER

- 60 to 0 minutes with seconds display.

#### 4. INTEGRATING TIMER

- 0 to 60 hours with minutes display.

#### 5. BATTERY ALARM

- Alarm sounds when the transmitter Nicd batteries approach the usage limit.



## 22 Monitor Lamps

**IMPORTANT:** In all instructions on control functions. Items designated by a number inside a circle (For example 10) are transmitter controls normally accessible and operated in flight.

Items designated by a number within a box (For example 10) are adjustment functions not operated while in flight.

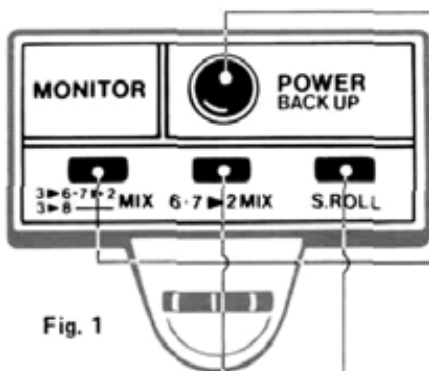

When the power switch 23 is set to ON, lamp A will go out momentarily. This indicates automatic data transmission on and is not a failure.

### Lamp A Power Monitor

- When the power switch 23 is set to ON, this lamp flashes on briefly and then goes out momentarily as the Fail Safe data is automatically transmitted to the receiver. Fail Safe data is transmitted every 60 seconds at which time the lamp also goes out momentarily. If the transmitter Nicd battery nears full discharge, this lamp starts blinking, indicating that the power error backup function is activated. When this occurs, transmitter memory function settings are lost and must be reset.

### Lamp B 3 -> 6, 7 -> 2 / 3 -> 8 Mix

This lamp comes on when Safety Switch 7 and/or 33 is set to ACT position, indicating that throttle — flap, spoiler -> elevator mixing and/or throttle — pitch control mixing functions are activated. This lamp will blink when transmitter control switch 11 is set to ON (placing these functions in operation).

### Lamp C 6, 7 -> 2 Mix

32

- This lamp comes on when Safety Switch 32 is set to ON (flap, spoiler — elevator mix) or CH7 OFF (flap -> elevator mix) position. This lamp blinks when transmitter control switch 10 is set to ON.

### Lamp D Snap Roll

- When Safety Switch 29 is set to ACT (snap roll function activated), this lamp blinks. When the Snap Roll switch 13 is pulled, this lamp continues blinking.

## 23 Power switch

- The transmitter power ON-OFF switch is provided with a locking feature to prevent accidental movement. To operate the switch, pull the knob gently outwards and set to the desired position (UP=ON, DOWN=OFF).

## 24 Hook

Metal hook for the accessory neck strap.

## 25 Level meter

- This meter indicates the transmitter battery voltage and output power.
- When the antenna 26 is extended fully and the power switch 23 is set to ON, the pointer should move to the white zone.
- If the transmitter RF Module 32 is not installed, the meter pointer will not move.
- If the meter pointer moves to the red zone, indicating that the Nicd battery voltage is low, the signal range will become shorter. If the Tachometer/timer 21 power switch is ON, the battery alarm function will operate after about one more flight. When the meter pointer stops at the boundary between the white and red zones, recharge the battery.

## 26 Antenna

Strong 1m 10cm telescoping antenna. Extend the antenna to its full height when using the transmitter. The antenna will lock in place with a click when pulled up to its full height.

## 27 Carrying handle

## 28 Tachometer sensor connector

- When not using this connector and the charging socket 29, cover them with the rubber-backed cover supplied to protect them against dust.

## 29 Charging socket and DSC (Direct Servo Controller) connector

- This connector is used as both the charging socket and DSC connector. See page 10 for charging instructions.

## 30 Non-slip adjustable lever head

The length of the lever head can be adjusted to fit the operator.

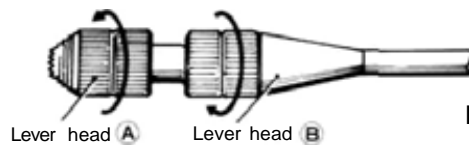

Fig. 2

Unlock lever heads A B, by turning them and in the arrow direction, and adjust the head to the most comfortable length.

- 31 Slantable stick adjusting screws  
The angle of the stick levers can be changed.

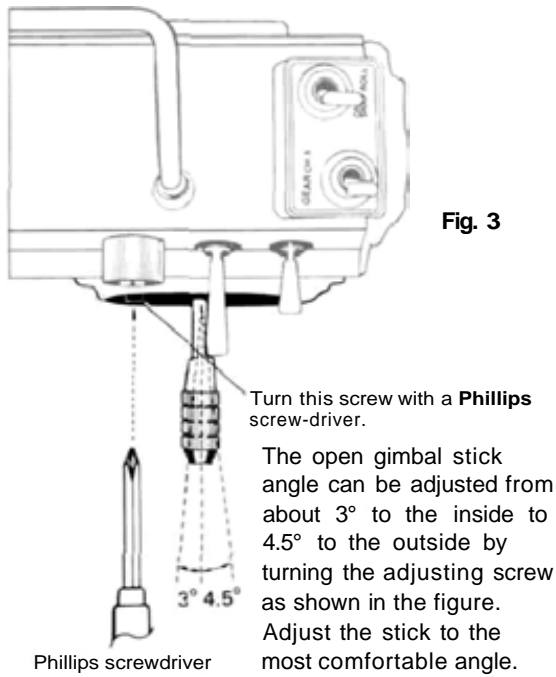

Fig. 3

The strength of the stick lever spring can be adjusted.

8

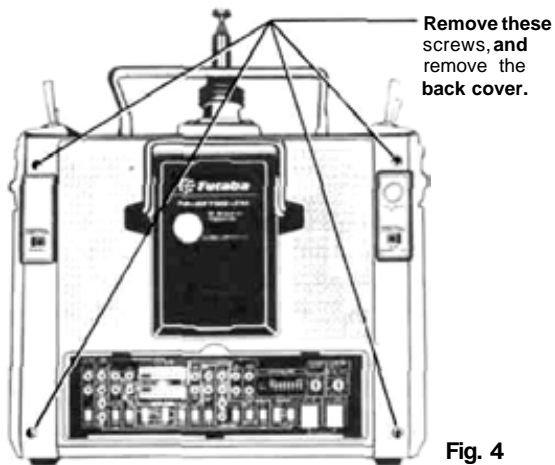

Fig. 4

### 32 Transmitter RF module

- Change this module when switching frequency bands (50, 53, 72, and 75MHz).

A temperature rise at the RF module section during use is normal.

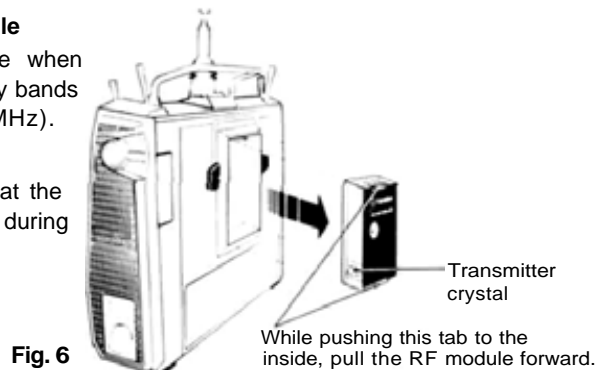

Fig. 6

### MODE I

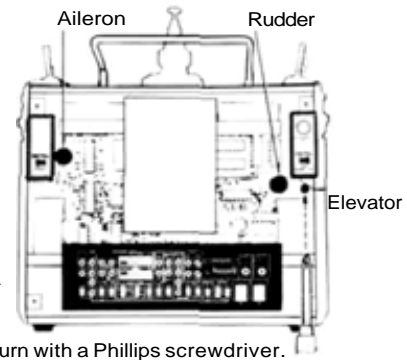

Fig. 5-A

Turn with a Phillips screwdriver.

The spring strength can be adjusted as desired by removing the transmitter back cover and turning the adjusting screw of each stick. Adjust the spring strength for the best stick feel.

### MODE II

- 1 Remove the three screws shown and remove the transmitter righthand side panel as shown in Fig.5-B.
- 2 Displace the side panel away from the case. (slid down-off)
- 3 Disconnect the power connector.
- 4 Adjust the spring tension.
- 5 Cautions
  - Be sure that the PC board attached to the side panel does not touch the transmitter case.
  - Disconnect the power connector before side panel completely off, while side down-ward, to avoid touching with TX case.
  - When the power connector is disconnected, the memorized contents (ATV, FS, etc.) are cleared. When flying again, reset the contents.

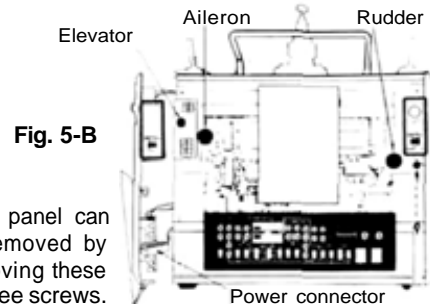

Fig. 5-B

The side panel can be removed by removing these three screws.

Power connector

**33 Mini stand**

- Use this stand as shown in Figure when laying the transmitter down. This makes operation easier and protects the RF module and transmitter back. The 4 rubber feet supplied can also be installed using the transmitter back screws.

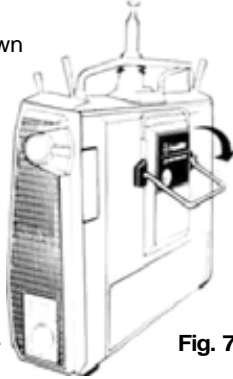

**Fig. 7**

\* NOTE: The 4 rubber feet supplied as accessories can be installed on the transmitter back (using the longer back cover retaining screws) to provide additional protection.

**Snap roll direction switch (R/L)**

**Snap roll direction switch (UP/DOWN)**

- These switches control the direction of the snap roll when the Snap roll switch 13 is used.

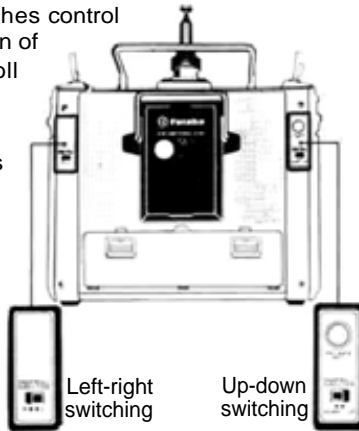

**Fig. 8**

**36 Fail safe set button**

- This pushbutton is used when setting the Fail Safe servo positions (FS instructions Page 25).



**Fig. 9**

**37 Back Cover**

- Removal of this cover exposes the trimmer panel. Remove as shown in Fig. 10.

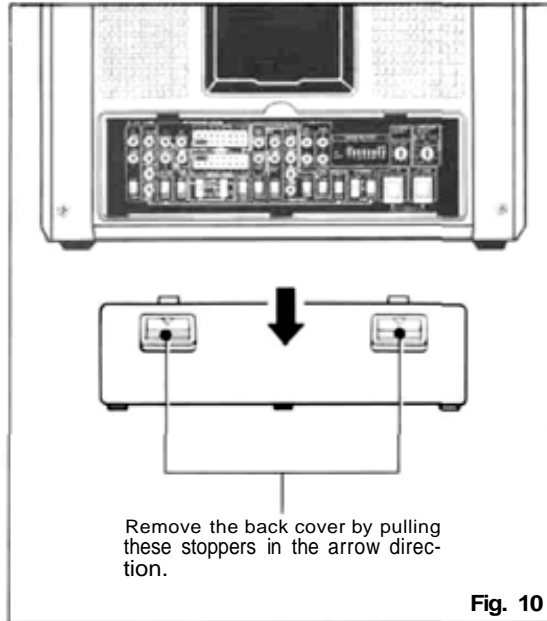

**Fig. 10**

**38 Trimmer Panel**

- This panel contains switches, buttons, and trimmers for setting and adjusting the many versatile transmitter functions. Use the small screwdriver supplied with the set for making adjustments.

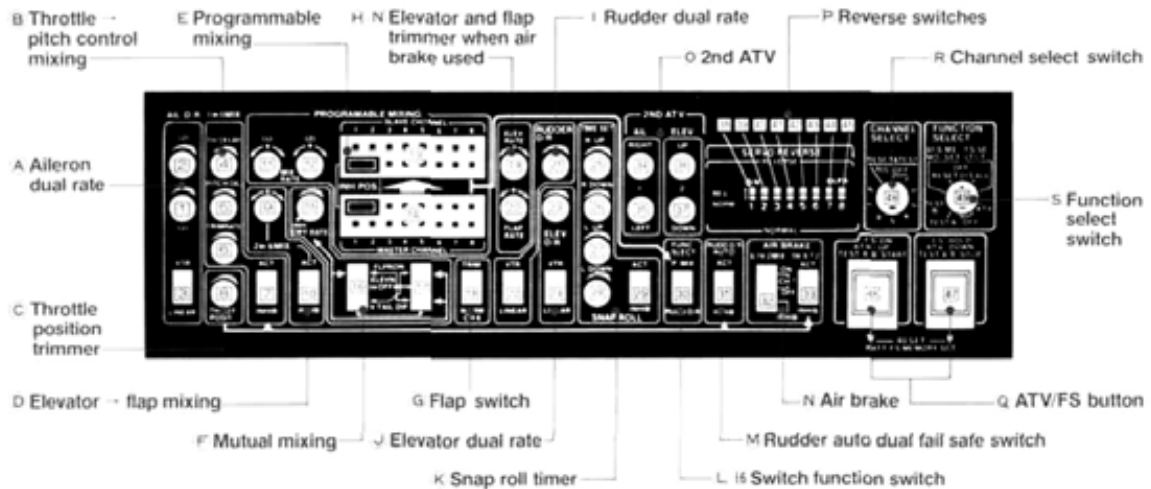

Use the transmitter with fail-safe switches 7, 10, 29, 31, 32, and 33 in the INHIB (function off) position until you become familiar with the set.

**Fig. 11**



# •TACHOMETER/TIMER OPERATION

## NOMENCLATURE AND FUNCTIONS

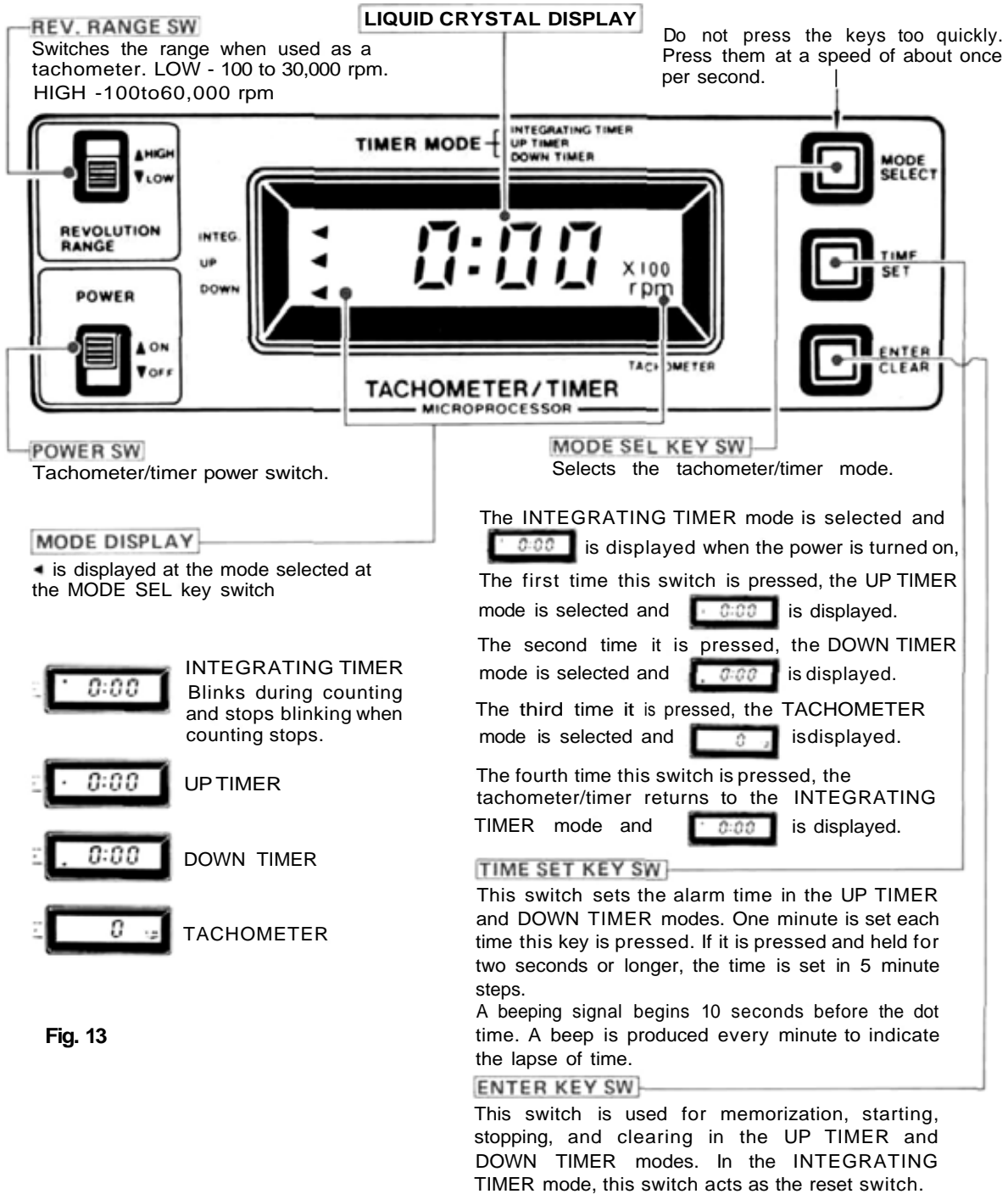





Fig. 13

**Do not expose the display to direct sunlight for a long time.**

## OPERATING INSTRUCTIONS

### 1 Tachometer

Set the tachometer/times POWER switch to ON.  appears on the display. Next, press the MODE SEL key switch at the upper-right corner three times. The display changes to  and the tachometer mode is selected. Hold the sensor about 20 to 30 cm from the rotating propeller (two blade). The propeller speed is displayed on the LCD.

 indicates that the propeller is rotating at 12,300 rpm. For propeller speeds up to 30,000 rpm, set the REVOLUTION RANGE switch at the upper left-hand corner to LOW and for propeller speeds above 30,000 rpm, set the REVOLUTION RANGE switch to HIGH.

The speed of a three blade propeller is displayed value- 3 x 2 .

The speed of a four blade propeller is 1/2 the displayed value.

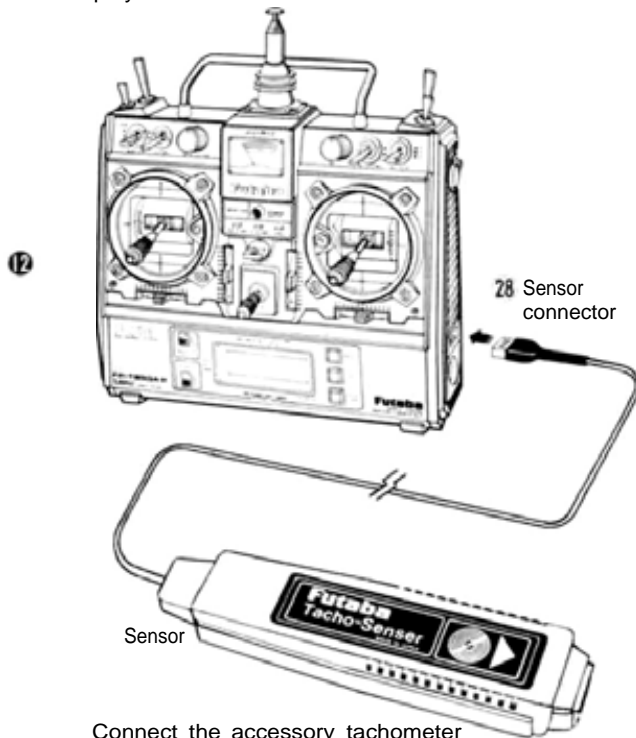

Connect the accessory tachometer sensor to the sensor connector 28 as shown above.

Fig. 14

Make all speed measurements outdoors under natural lighting. Accurate speed measurements cannot be made indoors under artificial lighting because of the affect of the 50 or 60 Hz power.

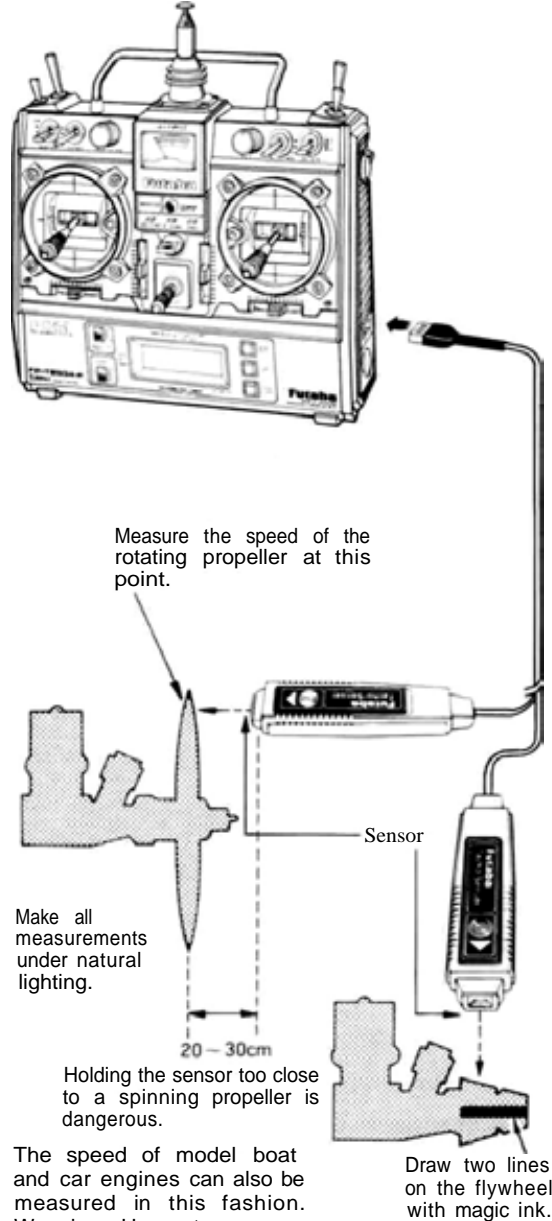

Fig. 15

To measure the speed of the main rotor of a model helicopter, measure the speed of the tail rotor as shown in Fig.16. and calculate the exact speed from the equation.

$$\text{Main rotor speed} = \frac{\text{Tail rotor speed}}{\text{Main rotor and tail rotor gear ratio}}$$

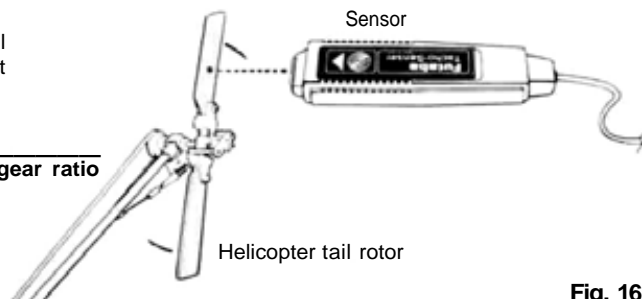

Fig. 16

Note do not expose the liquid crystal display to direct sunlight for a long time.



Fig. 17

## 2 UP TIMER

Set the tachometer/timer POWER switch to ON.  $0:00$  is displayed. Next, press the MODE.SEL key switch at the upper right-hand corner one time. The display changes to  $0:00$ , and the UP TIMER mode is selected. When the ENTER key switch at the bottom right-hand corner is pressed, a beep is heard and the timer starts and the second digit of the display changes every second. A beep is

produced every minute to indicate the passage of time. To stop counting, press the ENTER key switch again. The usage time is displayed on the display. For example,  $12:05$  means that 12 minutes 05 seconds had elapsed. The UP TIMER mode can be used as a second stop watch. To clear the display, press the ENTER key switch again.

## ALARM SETTING

The alarm can be set with the TIME SET key. Clear the display, by pressing the ENTER key, then press the TIME SET key twice.

$2:00$  appears on the display indicating that two minutes was set. Next, press the ENTER key once to memorize this two minutes. The display changes to  $0:00$  and is memorized. Start the timer by pressing the ENTER key. The display changes every second. When the display reaches  $1:51$ , the timer keeps ten times, every once a second, to indicate that two minutes have elapsed. Thereafter the timer continues to count up to 60 minutes. If the TIME SET key is pressed and held for two seconds or longer when memorizing the alarm time, the time is set in five minute steps and the set alarm times are memorized until

the power is turned off or reset. If the timer is started without setting the time after the display has been cleared, the previously set alarm time remains effective. An arbitrary alarm time up to 59 minutes can be set.

## 3 DOWN TIMER

Set the tachometer/timer POWER switch to ON and press the MODE SEL key twice.

$0:00$  appears on the display to indicate that the DOWN TIMER mode was selected. Next, press the ENTER key. The timer keeps  $50:00$  appears on the display, and the display begins to count down every second. The timer keeps every second from 10 seconds before the end of the count-down, the same as the UP TIMER.

## TIME AND ALARM SETTING

Set the time and alarm with the TIME SET key, the same as the UP TIMER. To set the alarm to  $3:00$  at the display, clear the display by pressing the ENTER key, then press the TIME SET key three times. Next, memorize this time by pressing the ENTER key again. The display begins to count down in seconds. When the display begins to count down in seconds. When the display reaches  $0:09$ , the timer begins to keep every second to indicate that three minutes have elapsed. If the TIME SET key is pressed and held for two or more seconds, the time is set in five minute steps, the same as the UP COUNTER, and the alarm can be set to any desired time up to 33 minutes.

## 4 INTEGRATING TIMER

Set the tachometer/timer POWER switch and the transmitter power switch to ON. The  $\blacktriangleleft$  blinks, counting begins, and the elapsed time is displayed in minutes. For example,  $0:03$  indicates that three minutes have elapsed. If the transmitter power switch is set to OFF, counting stops. When the transmitter power switch is turned back on, counting continues. The integrating timer function can be started and stopped as long as the tachometer/timer POWER switch is on even if another mode is selected with the MODE.SEL key. This can be used to monitor the transmitter operating time. If the ENTER key is pressed in the INTEGRATING TIMER mode, the old integrating time is cleared and a new count begins.

This can be used to forecast the remaining Nicd battery capacity and other applications.

# •RECEIVER AND SERVOS

## Receiver, Servo Switch, and Battery Connections

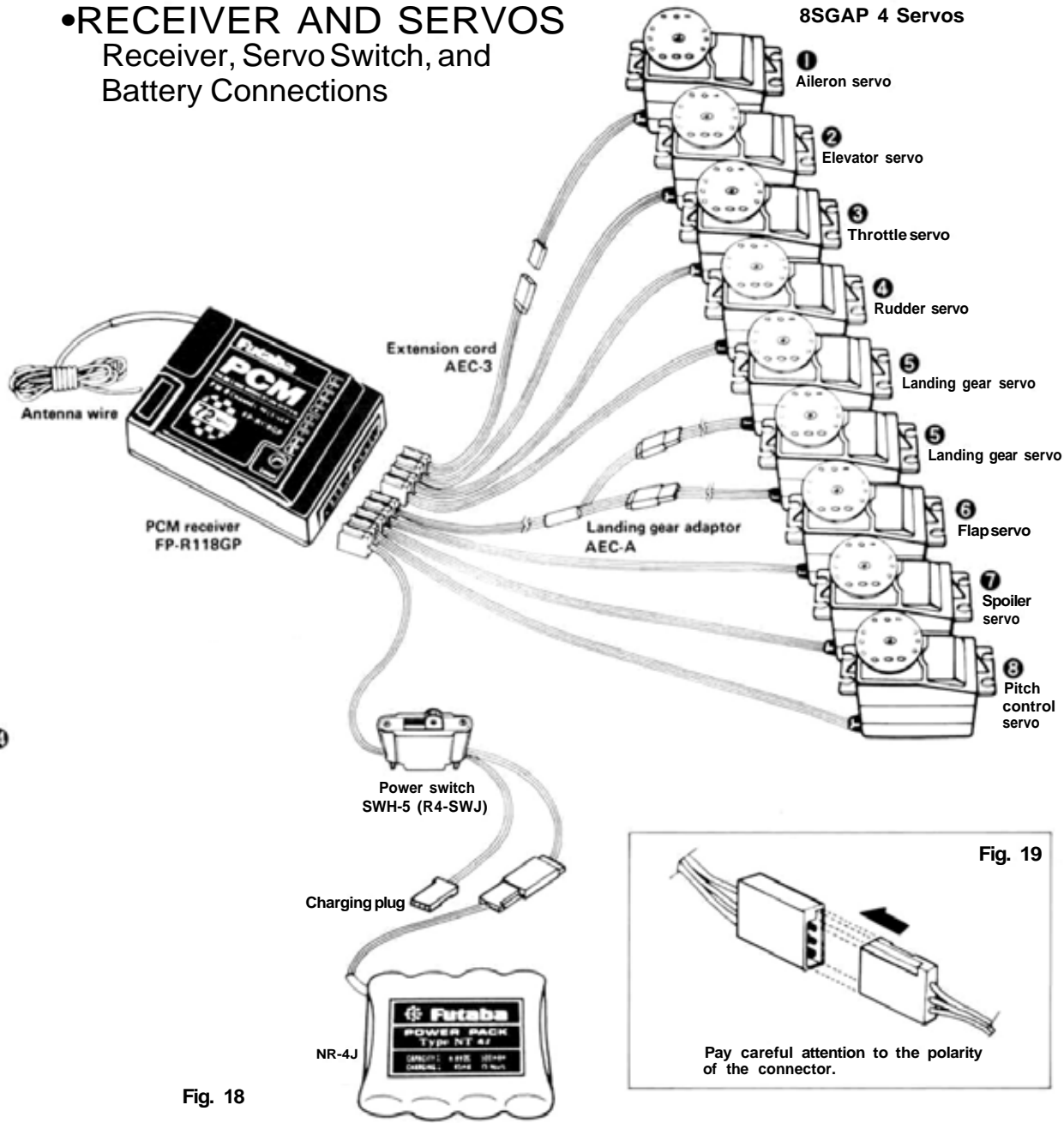
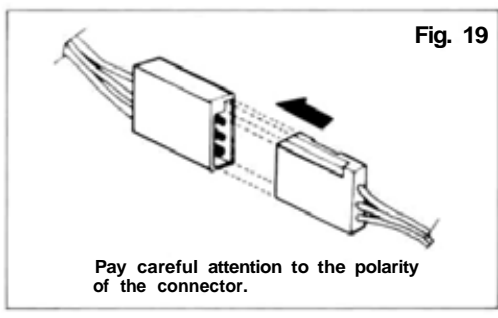

Fig. 18



**PCM RECEIVER FP-R118GP**

Antenna wire

Crystal

**Error lamp**

- This LED comes on when the receiver operated erroneously.
- When the receiver and servo side Nicd is connected and this LED is on, radiowaves are not being received from the transmitter, check to be sure the frequency is correct. Checking is possible by the lamp being on.
- When strong noise has been received, or the radiowaves from the transmitter are intermittently interrupted, this lamp will blink. This is usually not a problem.

Remove the receiver crystal by pulling it in this direction.

Receiver crystal

Fig. 20

Fig. 21



# •FP-S130 AND FP-S130G EXPLODED VIEWS

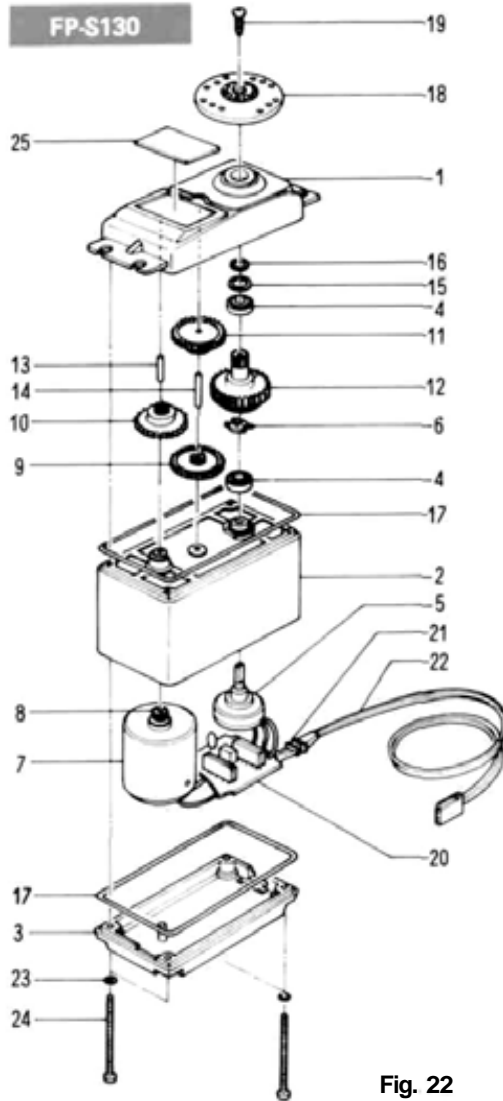

Fig. 22

No.	PartName	Part No.
1.	Upper case	FCS-30
2.	Middle case	FCS-30
3.	Bottom case	FCS-30
4.	Ball bearing	S04130
5.	Potentiometer	139995
6.	VR drive plate	S02753
7.	Motor	S91243
8.	Motor pinion	S02461
9.	1st gear	FGS-30
10.	2nd gear	FGS-30
11.	3rd gear	FGS-30
12.	Final gear	FGS-30
13.	2nd shaft	S02481
14.	Intermediate shaft	S02480
15.	Spacer washer 0.3T	S02486
16.	Seal ring	S90415
17.	O-ring	S90426
18.	Servo horn D	FSH-6W
19.	Horn mounting screw	FSH-41
20.	S130 printed wiring board	AS1220
21.	Lead wire packing	S90045
22.	S1303PB-WRB-300	FPC-8M
23.	Screw O-ring	S90410
24.	Case mounting screw	J50085
25.	S130Nameplate	S60101

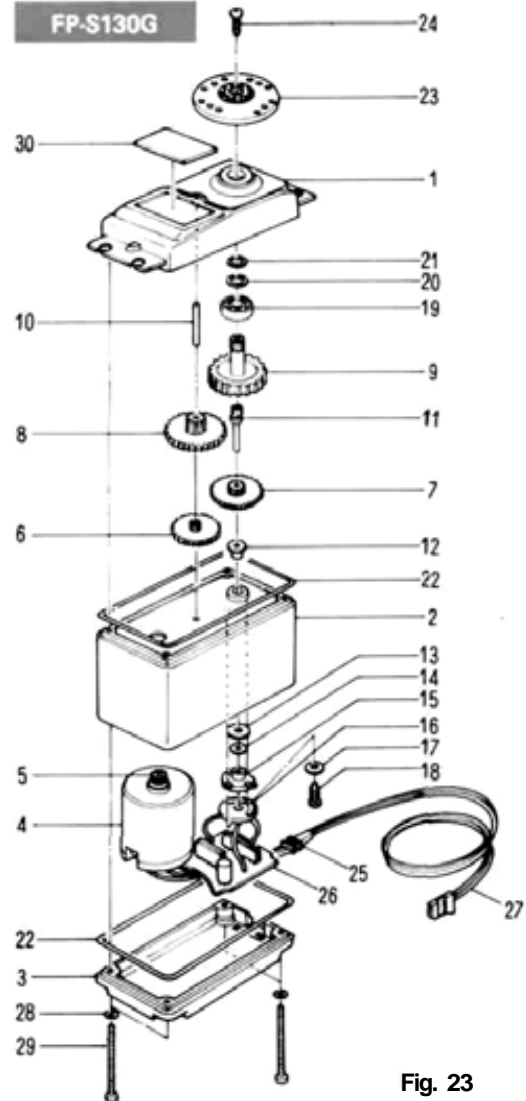

Fig. 23

No.	Pan Name	Part No.
1.	Upper case	FCS-30G
2.	Middle case	FCS-30G
3.	Bottom case	FCS-30G
4.	Motor	S91243
5.	Motor pinion	S02461
6.	1st gear	FGS-30G
7.	2nd gear	FGS-30G
8.	3rd gear	FGS-30G
9.	Final gear	FGS-30G
10.	Intermediate shah	S02480
11.	Output shaft	S02803
12.	Output shaft bearing	S02804
13.	Bent washer for SX	S11043
14.	Push nut	J60070
15.	Metal slider 0.08T	140002
16.	TR.13VR Body 165D	140000
17.	Fiber washer 20	S90332
18.	Binding head lapping screw	J55016
19.	Ballbearing	S04130
20.	Spacer washer 0.3T	S02486
21.	Seal ring	S90415
22.	O-ring	S90426
23.	Servo horn 0	FSH-6W
24.	Horn mounting screw	FSH-41
25.	S130G Printed wiring board	AS1224
26.	Lead wire packing	S90045
27.	S130G 3PBWRB-300	FPC-8M
28.	O-ring	S90410
29.	Case mounting screw	J50085
30.	S130G Name plate	S80706

# •SPLINED HORNS

The following splined horns are optional.

Fig. 24

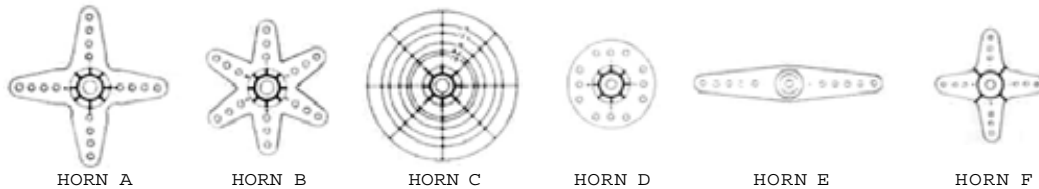

This horn permits shifting of the servo neutral position at the servo horn. Setting and shifting the neutral position

a) Angle divisions

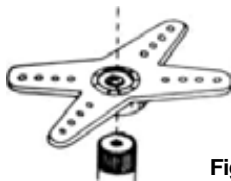

Fig. 25

- 1) The splined horn has 25 segments. The amount of change per segment is;  $360-25=14.4^\circ$
- 2) The minimum adjustable angle is determined by the number of arms or number of the holes. For four arms, the minimum adjustable angle is:

$$360^\circ \div \frac{(25 \times 4)}{\text{Number of divisions}} = 3.6^\circ$$

b) Effect

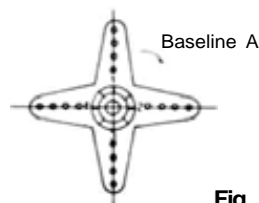

Fig. 26

To shift the holes center line to the right (clockwise) relative to baseline A, shift arm 2 to the position of arm 1 and set it to the position closest to baseline A. (Example] For a four arm horn, the angular shift per segment is  $14.4^\circ$ . The shift to the right is  $90^\circ - (14.4 \times 6) = 3.6^\circ$ . To shift by the same angle in the opposite direction, use the opposite arm number.



Fig. 27

For a six arm horn, turn the arm counterclockwise and set arm 2 to the position of arm 1. The adjustable angle is  $60^\circ - (14.4 \times 4) = 2.4^\circ$ .

Arm 3 shift  $4.8^\circ$  to the right, arm 6 shifts  $2.4^\circ$  to the left, and arm 4 shifts  $7.2^\circ$  to the right and left.



Fig. 28

## Futaba Digital Proportional Frequencies (FOR U.S.A.)

- The frequency of Futaba digital proportional sets can be changed among bands (1)-(6) on the 27MHz band only.
- However, a 27MHz band set cannot be changed to 72MHz band, and vice versa.
- Therefore, always attach the correct frequency flag to the end of the transmitter antenna. Each frequency band has its own designated color, as stated above. The frequency flag is intended for identification purposes.
- Also change the frequency flag when frequency is changed.
- Futaba paired crystals are precisely matched. Always use a Futaba crystal set (transmitter, receiver) when changing the frequency.
- It is illegal to change crystals of transmitter on the 72-75MHz bands in the U.S.A.

Frequency Channel No. Flag Color	
<b>26-27MHz - Aircraft/Car/Boat</b>	
26.995	- Brown
27.045	- Red
27.095	- Orange
27.145	- Yellow
27.195	- Green
27.255	- Blue
<b>72/75MHz - Aircraft only *Shared</b>	
72.030	12 Brown-Red (Top Flag/Ribbon- Bottom Flag/Ribbon)
72.080	- White/Brown
72.160*	- White/Blue
72.240	- White/Red
72.320*	- White/Purple
72.400	- White/Orange
72.550	38 Orange-Grey
72.590	40 Yellow-Black
72.630	42 Yellow-Red
72.670	44 Yellow-Yellow
72.710	46 Yellow-Blue
72.750	48 Yellow-Grey
72.790	50 Green-Black
72.830	52 Green-Red
72.870	54 Green-Yellow
72.910	56 Green-Blue
72.960*	- White/Yellow
75.640	- White/Green
<b>75MHz - Car &amp; Boat only</b>	
75.430	62 Blue-Red (Top Flag/Ribbon- Bottom Flag/Ribbon)
75.470	64 Blue-Yellow
75.510	66 Blue-Blue
75.550	68 Blue-Grey
75.590	70 Purple-Black
75.670	74 Purple-Yellow
75.710	76 Purple-Blue
75.750	78 Purple-Grey
75.790	80 Grey-Black
75.830	82 Grey-Red
75.870	84 Grey-Yellow
<b>53MHz - Aircraft/Car/Boat - FCC Amateur License Required</b>	
53.100	- Black/Brown
53.200	- Black/Red
53.300	- Black/Orange
53.400	- Black/Yellow
53.500	- Black/Green
53.600	- Black/Blue
53.700	- Black/Purple
53.800	- Black/Grey

Not generally in use

# ADJUSTMENTS AND FLIGHT TECHNIQUES

## •BASIC LINKAGES AND INSTALLATION

The FP-8SGAP has a servo reversing switch and ATV (Adjustable Travel Volume) for each channel. Mount the servos without regard to their direction. Select and link servo horns somewhat larger than those specified by the model manufacturer.

- Install the servos securely. Tighten the mounting screws until the rubber grommets are slightly compressed. Note: If the screws are too tight, the vibration dampening effect of the grommets will be lost.
- Use extension cords as needed.
- It is suggested that a separate servo be used on each aileron as this will allow use of the versatile mixing and differential functions built into the transmitter. Retractable landing gear can be operated with a single servo to save weight or with two servos to simplify the mechanical linkage as desired.
- Connect the pushrod to each servo horn, then check to see if the direction of travel in relation to stick movement is correct. If the direction of travel is reversed, use the servo reversing switches to correct.
- When installing the switch harness, cut a rectangular hole slightly larger than the full stroke of the ON/OFF switch and install the switch so that it operates smoothly. It is best to install the switch inside the fuselage and attach a piece of wire to the switch so that it can be operated from outside the aircraft. Locate the switch where it will not be exposed to engine oil, dust, etc.
- Wrap the receiver in soft foam rubber. Water- and dustproof the receiver by placing it in a plastic bag and tying the mouth of the bag with a rubber band. Do the same with the airborne battery pack. Caution: The foam rubber should be loosely wrapped and not compressed. This will provide maximum protection from vibration.
- Use the rubber bands wrapped around the receiver to hold the servo and switch leads.
- Even though the receiver antenna may appear to be too long, do not shorten it or fold it back.
- Be alert for possible electrical noise. This system has noise rejection circuits, however noiseless parts are recommended.
- Operate each servo to its full throw and check for slop or binding in the linkage. Unreasonable force applied to the servo horns can damage the servo or horns and will greatly shorten battery life. Adjust linkages and servo horns so that the servos move smoothly even when the trim lever and stick are operated simultaneously in the same direction.
- After installation is complete, recheck each part, then perform a range check by collapsing the transmitter antenna and extending the receiver antenna to its full length. Operate the transmitter at a distance of 60 to 90 feet from the receiver. The servos should operate normally at this distance.

### Normal 8 channel use (mixing and other functions not used).

Set the switches on the trimmer panel at the back of the transmitter as shown below. The switches are set as shown in Fig. 29. Connect the aileron servo to CH1, elevator servo to CH2, throttle servo

to CH3, rudder servo to CH4, landing gear servo to CH5, flap servo to CH6, spoiler servo to CH7, and the pitch control servo to CH8.

Fig. 29

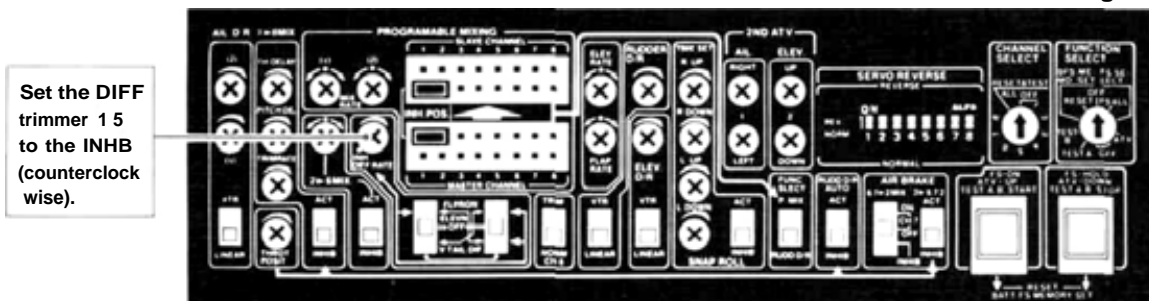

DIFF trimmer 15 set to INHB Counterclockwise. Note: Monitor Lamps (B), (C), and (D) do not come on at this time. Check if the direction of operation of each servo is correct under this state. If the direction of operation of a servo is incorrect, reverse the position of the corresponding servo reversing switch [38] to [45]. Next, set the 2ND

ATV trimmers on aileron and elevator to the desired deflection angles on the aircraft. The deflection angle decreases when the 2ND ATV trimmer is turned counterclockwise. Throttle control can be adjusted with the ATL trim lever 19. This completes the settings for basic 8 channel use.

## •USING ATV (ADJUSTABLE TRAVEL VOLUME)

GENERAL - **ATV** (Adjustable Travel Volume) allows independent adjustment of servo maximum throw in each direction (without affecting the neutral position). This is also sometimes referred to as "separate endpoint adjustment". ATV is very convenient when for example: a model requires more DOWN elevator deflection than UP for equal inside and outside loops (with equal control stick

deflection). Other aircraft may require slightly different RIGHT or LEFT aileron or rudder deflection to give equal response in each direction (due to engine torque, precision of the model, etc.). Two different ATV functions are possible with this system. Memory (Pushbutton) ATV and 2ND ATV.

### MEMORY (PUSHBUTTON) ATV

This type of ATV is available on all eight channels. Servo travel is adjusted as outlined in the example below.

NOTE: Memory ATV settings are retained in the transmitter memory circuit even when the power switch is turned OFF. They are lost however, if the transmitter Nicd battery nears full discharge or is removed for servicing.

#### ATV SETTING

Switch switches (S), [49] and (R) [48]

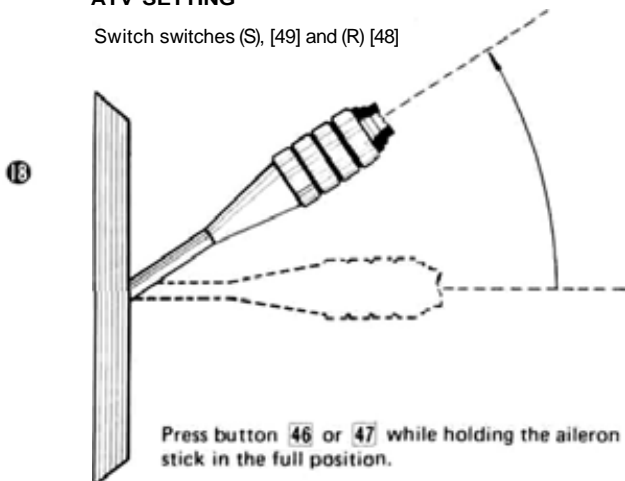

Fig. 30

### MEMORY (PUSHBUTTON) ATV - (Aileron CH1 used as example)

- 1 First, set Function Select Switch [49] to ATV position.
- 2 Set Channel Select Switch [48] to 1 (Ail.).
- 3 Set the transmitter and receiver power switches ON and check for proper servo operation.
- 4 Move the Aileron stick to full RIGHT aileron, hold it in that position, and set servo movement to the desired Right aileron deflection angle by pressing Button [46] or 47.
- 5 Repeat Step 4 for LEFT aileron.
- 6 For other channels, select the channel with switch 48 and adjust ATV as desired.
- 7 When all adjustments are completed, set the Function Select and Channel Select switches ([48] and [49]) to OFF.
- 8 To clear the ATV settings on all channels, set the Function Select switch [49] to RESET and Channel Select switch 48 to POSITION 2 (Pos. 2 = ATV when 49 is on RESET) and press Buttons 46 and 47 simultaneously. ATV is cleared on ALL CHANNELS and servos will move to 100% of their maximum throw.
- 9 If only one channel is to be cleared or changed, simply repeat Steps 1 through 5 with Channel Select Switch [48] set to the appropriate channel.

### ATV/FS BUTTON

•These two pushbutton switches are used for servo deflection angle setting of ATV, FS or HOLD function, servo test start & stop; reset; battery FS memory set, etc.

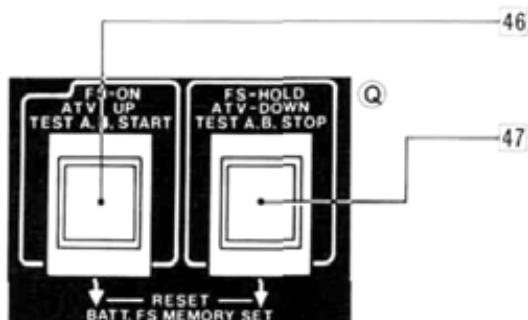

Fig. 31

This pushbutton switch is used when:

- 1 Making the ATV servo deflection angle larger.
- 2 Turning the FS function on.
- 3 Starting the servo test.

This pushbutton switch is used when:

- 1 Making the ATV servo deflection angle smaller.
- 2 Turning the HOLD function on.
- 3 Stopping the servo test.

When button 46 and 47 are pressed at the same time, reset or battery FS memory setting is possible. At this time, lamp A of memory lamps 22 goes out momentarily so that setting can be monitored.

# ADJUSTMENTS AND FLIGHT TECHNIQUES

## CHANNEL SELECT SWITCH

- This switch 48 selects the channel when setting FS and HOLD functions. It also acts as the channel select switch for SERVO TEST function. When switch 49 is set to RESET, the Channel Select switch is used to designate the function (ATV, FS, BFS memory, or ALL) to be cleared by Buttons 46 and 47. Note that the positions on switch 48 have a different meaning when the Function Select Switch is set on RESET. This is summarized in the table below:

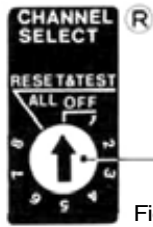

48 Channel select switch  
Fig. 32

[48 Relationship among channel select switch number, servo and reset.

No.	At switch [49] FS SELECT, ATV, TEST A.B	At switch [49] RESET
1.	Aileron	FS (fail safe)
2.	Elevator	ATV
3.	Throttle	BFS memory
4.	Rudder	
5.	Channel 5 switch (landing gear)	
6.	Flaps	
7.	Channel 7 knob (spoiler)	
8.	Channel 8 lever (variable pitch)	
RESET & TEST ALL	All the servos are operated at servo test.	FS, ATV, and BFS memory are reset simultaneously.
OFF	Usually set to this OFF position.	

## FUNCTION SELECT SWITCH

- This switch selects the function to be set (ATV, FS, BFS memory) or test (A or B) to be performed. It is also used in the RESET position to clear ATV, FS, and BFS memory (in conjunction with 46, 47, and 48). Note: In RESET position, the Channel Select Switch 48 is used to designate the function(s) to be cleared.

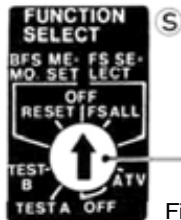

49 Function select switch  
Fig. 33

- Normally set it to OFF.

### 1 FS ALL

Switch to this position when setting fail safe for all channels, FS is described in the "HOW TO USE FS" section.

### 2 FS SELECT

This position allows setting of fail safe and hold as described in the "HOW TO USE FS" section.

### 3 ATV

This position allows setting ATV as described in the "HOW TO USE ATV" section.

### 4 TEST A

This position allows servo test A as described in the "SERVO TEST" section.

### 5 TEST B

This position allows servo test B as described in the "SERVO TEST" section.

### 6 BFS MEMO SET

Switch to this position when setting the BFS release point as described in the "BATTERY FS MEMORY SETTING" section.

### 7 OFF

Normally set to this position.

## PCM GREEN CHARACTER NAMEPLATE AND RED CHARACTER NAMEPLATE RC SET COMPATIBILITY

- When a red character nameplate transmitter and a green character nameplate receiver are used as a pair, only the 2 FS SELECT function of the FUNCTION SELECT switch described above is operative. In this case, switch is set to 1 FS ALL and the receiver mode selector switch is set to FS. The fail safe function is ON for all channels.

(When using the hold mode, set the receiver mode selector switch to HOLD.)

- When a green character nameplate transmitter and red character nameplate receiver are used as a pair, all the function of the transmitter are operative.

## •2ND ATV (CONVENTIONAL)

2ND ATV is available on the aileron and elevator channels. This is the conventional type ATV and is set using trimmers [34], [35], [36], and [37] on the transmitter back panel.

Servo movement can be adjusted from 0 to 100%. These adjustments are retained even if the transmitter battery reaches a full discharge state (Memory ATV settings are not.).

When the ATV trimmer is turned clockwise, the steering angle increases. When the ATV trimmer is turned counterclockwise, the steering angle decreases. The steering angle can be adjusted from 0 to 100%.

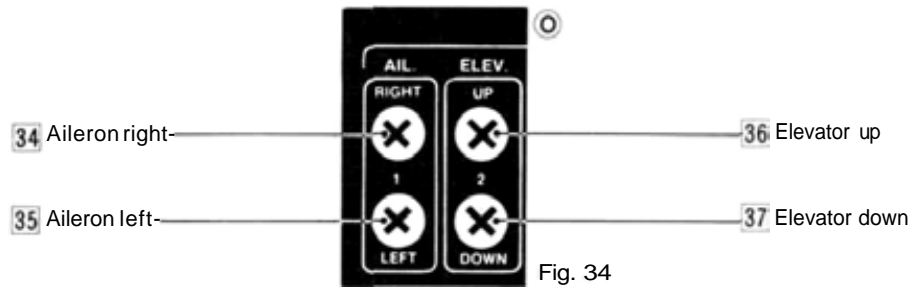

20

## •SERVO REVERSING SWITCHES

These switches reverse the direction of rotation of the servos. They are convenient when connecting the linkage.

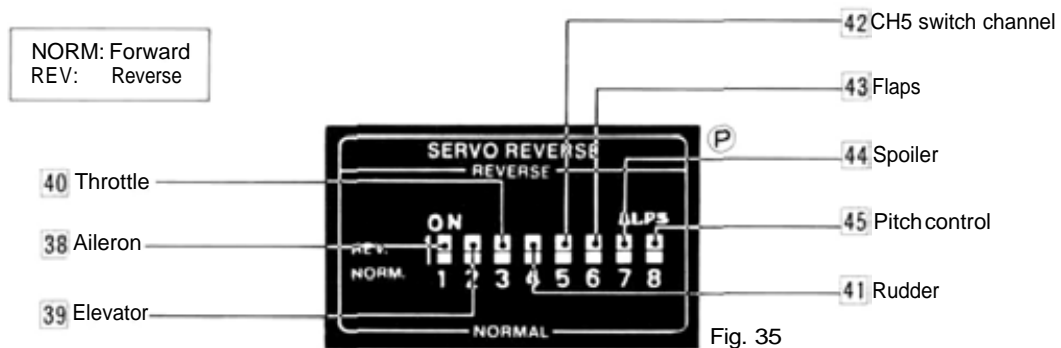

## • USING DUAL RATE (AILERON, ELEVATOR, AND RUDDER)

Dual rate functions allow the flyer to alter the maximum servo travel (and therefore control sensitivity) during flight by using the appropriate rate switch. At D/R OFF, servo deflection is maximum in both directions (unless limited by ATV set-

tings). At D/R ON, servo deflection is reduced by a percentage set with the D/R trimmers. Dual rate adjustments always effect both directions of servo travel.

### AILERON DUAL RATE

- The aileron rate switch 14 has two D/R ON positions. Thus three different servo travel rates are available on aileron. Rates can be adjusted to suit varying aircraft and maneuver requirements.

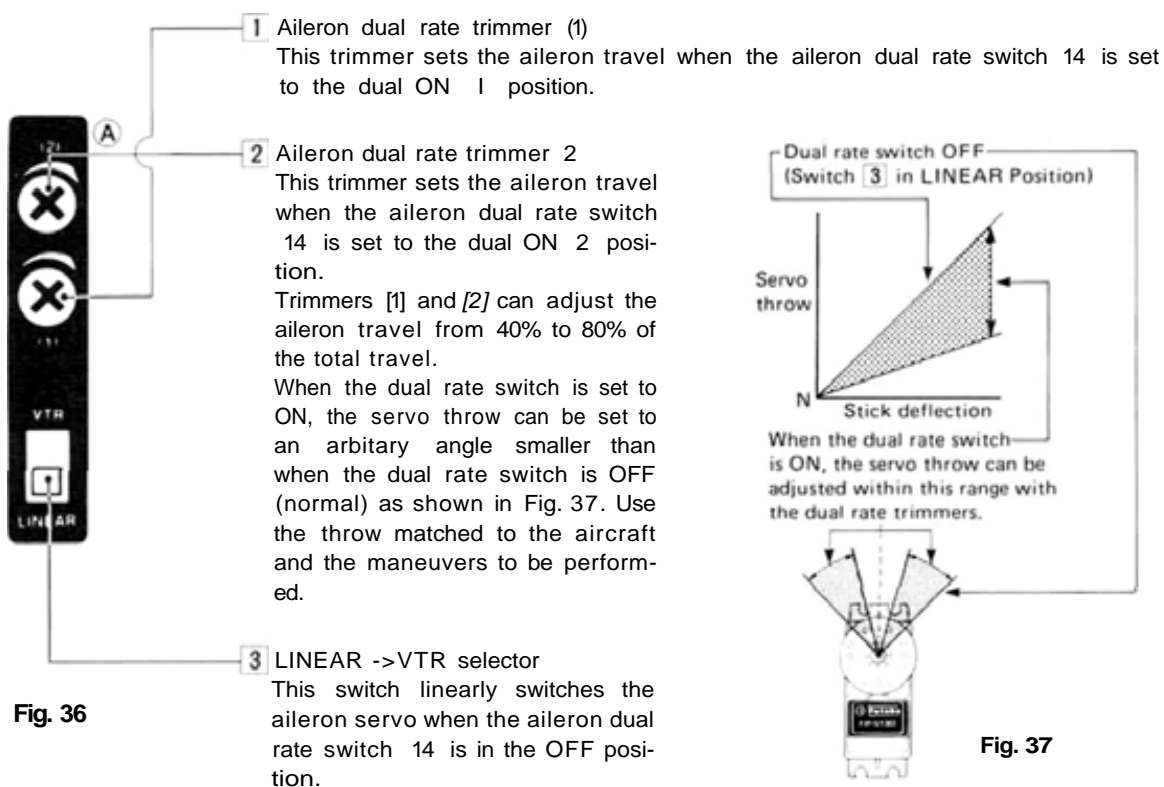

### ELEVATOR DUAL RATE

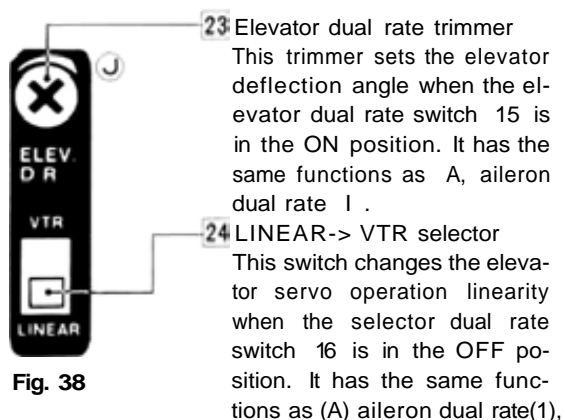

### RUDDER DUAL RATE

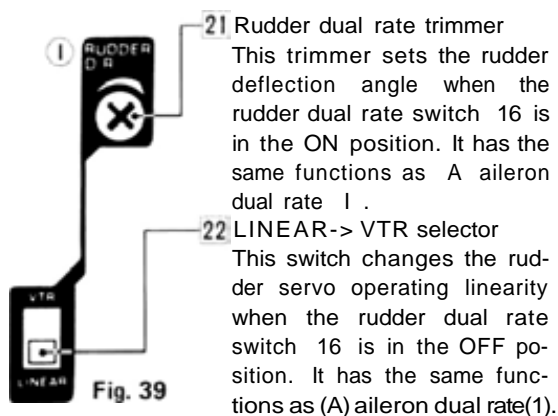

## •RUDDER AUTO DUAL RATE

•This function automatically switches rudder D/R to ON as the throttle lever is moved from LOW to HIGH position. This allows a smaller rudder throw for precise inputs during rolling maneuvers (at HIGH throttle) and increased throw (at LOW throttle) during stall turns, taxing, etc.

- 1 Safety Switch [31]<sup>1</sup> is set to ACT.
- 2 Adjust desired Rudder travel in D/R ON using Trimmer [21].
- 3 Throttle Position Trimmer 8 can be used to set the throttle stick position at which D/R is turned ON and OFF. Medium slow is recommended.

### SWITCH 16 FUNCTION SELECTOR

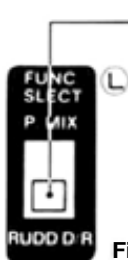

Fig. 40

•Transmitter control switch 16 can be used as a Rudder D/R switch or for turning the programmable mixing function ON and OFF. Usage is determined by the Function Select switch [30] on the transmitter back panel.

•When switch 30 is set to the P MIX position the programmed mixing function can be turned ON

or OFF with switch 16. The Rudder D/R function will not operate unless Rudder Auto D/R function is used.

•When switch [30] is set to the RUDD D/R position, the rudder D/R can be turned ON or OFF with Switch 16. In this mode, the programmed mixing function will remain on regardless of Switch 16.

### RUDDER AUTO DUAL RATE SAFETY SWITCH

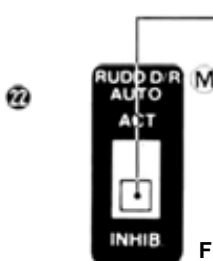

Fig. 41

•When the Rudder Auto D/R Safety Switch 31 is set to ACT, rudder auto D/R is ON. If Function Select Switch [30] is also set to RUDD D/R, the rudder D/R can be turned ON and OFF with control switch 16 but the rudder auto D/R function will still remain activated regardless of Switch 16.

•When switch [31] is set to INHIB, the rudder auto D/R function is inoperative. If Function Select switch [30] is in the RUDD D/R position, the rudder D/R function can be turned ON or OFF with control switch 16. Trimmer 21 sets the rudder D/R and Auto D/R deflection angles.

## •USING VTR (VARIABLE TRACE RATIO)

•VTR (Variable Trace Ratio) is a new type of non-linear control response. It is similar to Exponential Control, but is easier to use. Aileron will be used as an example.

•When the Aileron LINEAR/VTR Switch [3] is in the LINEAR position, servo travel is linear and directly proportional to the deflection of the transmitter control stick as shown in Fig. 42. In the VTR position (Ail. D/R Switch 14 must also be in D/R OFF pos.), servo maximum throw is unchanged. However servo tracking is the same as when the rate switch is in the D/R ON position up to about 80% of the transmitter stick deflection. Servo throw then abruptly increases to the same deflection as when D/R Switch 14 is in D/R OFF position. Fig. 42 shows the servo movement curve when VTR is used. Another way to think of VTR is as "automatic dual rate" that is switched off automatically as the control stick is moved past the 80% deflection point.

- Note: Maximum servo travel is the same in both LINEAR and VTR modes and is determined by ATV settings or maximum travel of the servo itself if no ATV is set.
- If rate switches are set to D/R ON while in the VTR mode, servo tracking will revert to LINEAR and travel is set by the D/R trimmer.

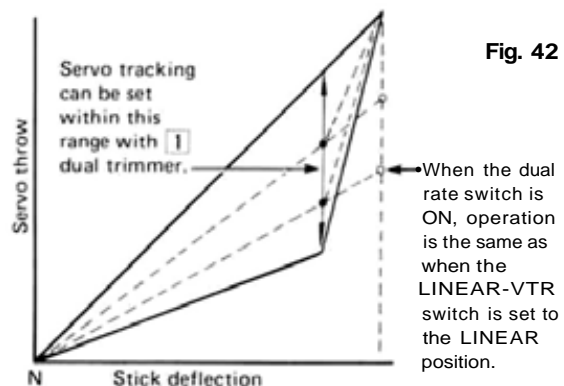

Fig. 42



## •SUGGESTIONS ON ATV, D/R, AND VTR

### POINTS TO REMEMBER (ATV, D/R, VTR)

- Servo maximum deflection is always determined by ATV. If no ATV is set, maximum travel is governed by the servo itself and is approximately 45 degrees in each direction from neutral.
- When Dual Rate is ON, servo travel in each direction is reduced by the same percentage (adjustable using D/R trimmers). For example, in Fig. 43 one direction has been limited using ATV. Both sides are reduced 20% when D/R is ON. In other words, the ratio of UP to Down will be maintained when D/R is ON or OFF.
- VTR operates only when D/R is set to OFF position (LINEAR/VTR switch must also be set to VTR position).
- Servo tracking is always LINEAR when Dual Rate is ON (regardless of LINEAR/VTR switch).

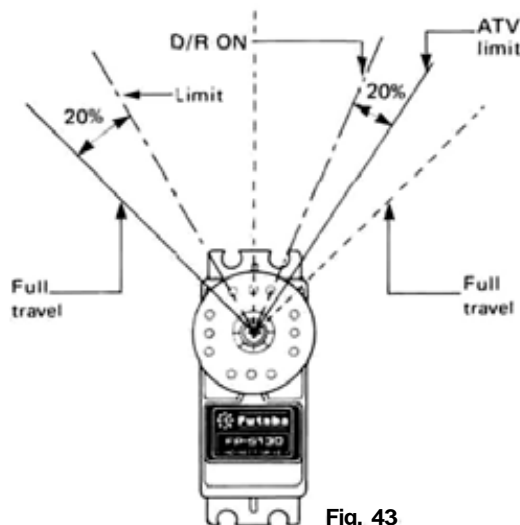

Fig. 43

### SUGGESTIONS

- VTR is useful when different throw rates are desired for different portions of the same maneuver or when there may be insufficient time between maneuvers for changing rate switches manually such as in the FAI F3A or "Turn-around" Pattern event.
- When preparing to test fly a new model, if **you** are unsure as to the amount of Aileron deflection needed, set up as follows.
  - 1 LINEAR/VTR switch 3. on LINEAR
  - 2 Aileron D/R 1 at best estimate of desired throw for normal flying or deflection specified on aircraft plans.
  - 3 Aileron D/R 2 less movement than D/R (1)
  - 4 D/R OFF set to provide somewhat more throw than specified.
  - 5 Set Ail. D/R Switch 14 to 1, position for takeoff.
  - 6 If aileron response is not comfortable, it can easily be increased or decreased while airborne.

- Try this set-up for AMA Pattern:

- 1 Aileron LINEAR/VTR Switch [3] set to LINEAR.
- 2 Adjust D/R 1 to give 3 rolls in approximately 5 seconds.
- 3 Use ATV to adjust for a fast roll rate when D/R Switch 14 is OFF.
- 4 Adjust D/R 2 for slow roll (1 roll in 5 seconds).

OR

Same as above except Aileron LINEAR/VTR Switch [3] set to VTR position.

# ADJUSTMENTS AND FLIGHT TECHNIQUES

## • USING ATL (ADJUSTABLE THROTTLE LIMIT)

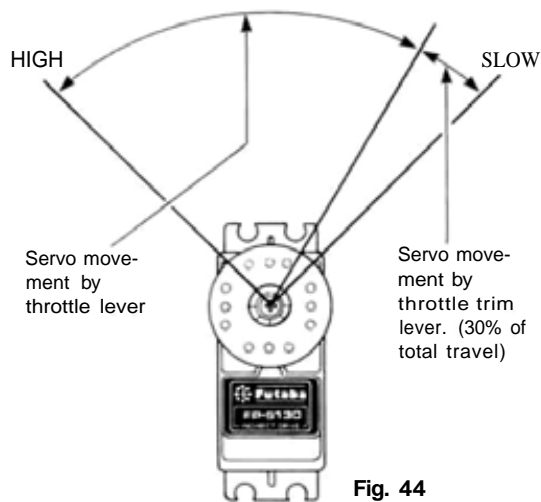

Fig. 44

The Throttle Trim Lever 19 affects the servo position only when the throttle control stick is in the LOW (IDLE) position. HIGH throttle position remains unchanged. Adjustment of the throttle linkage is therefore very convenient.

- 1 Use a servo horn that allows slightly more throw than needed.
- 2 Set the maximum opening at HIGH throttle using Memory ATV (Page 18).
- 3 Use Memory ATV to set the extreme LOW position to prevent servo binding when the throttle barrel closes against the idle stop screw.
- 4 With the engine running, use ATL Throttle Trim Lever 19 to set the optimum idle speed.

### FS FUNCTION/HOLD FUNCTION

Fail Safe (FS) is a function which moves the servo of each channel to a position preset (at the transmitter) when an erroneous signal or continuous strong noise is received for about 1 second or longer. When the proper signal is lost or strong interference received, the airborne system will operate in the HOLD mode for about 1 second before switching to the FS mode. When a normal signal is received again for about 1 second, FS is released and normal control resumes.

The HOLD function stops all servos selected (by button [47] at the position just before noise or interference was received. When a normal signal is resumed, HOLD is released.

A combination of FS and HOLD functions can be selected on each channel at the modeler's discretion.

FS, HOLD, and SERVO TEST functions are operated using three switches on the trimmer panel.

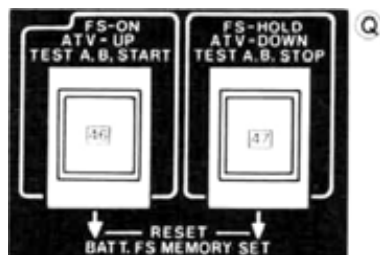

Fig. 45

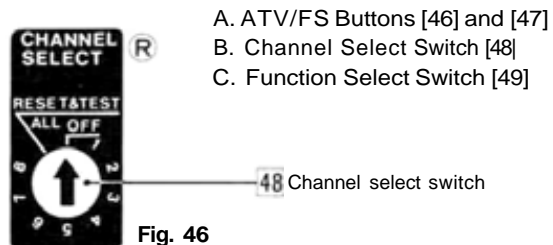

Fig. 46

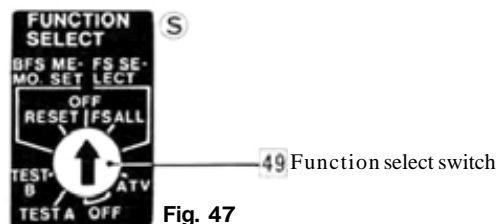

Fig. 47

## •FS (FAIL SAFE) AND HOLD FUNCTIONS

### HOW TO USE FS (FAIL SAFE) (THROTTLE CHANNEL AS AN EXAMPLE.)

- ❶ Set Function Select Switch 49 to FS SELECT.
- ❷ Set transmitter and receiver power switches to ON and check servo movements.
- ❸ While switching the Channel Select Switch 48 from 1 to 8 in order, set the channel(s) to be used with FAIL SAFE by pressing Button 46 and those to be used with HOLD by pressing Button 47. (In this example, set CH3 to FS with Button 46.)
- ❹ Move the throttle lever to maximum slow position, and press the FS Set Button 36 on the transmitter back.
- ❺ CH3 is now set to LOW throttle for the FS function. After setting FS, turn the Channel Select Switch 48 and Function Select Switch 49 to OFF.
- ❻ Test FS by turning the transmitter power switch to OFF. (In this example, all servos should move to neutral except the throttle servo which should move to the LOW position that was just set.)
- ❼ Fail Safe for all channels selected can be set with one touch by moving the sticks and switches of all the channels to the desired positions and pressing the FS Set Button 36 once. (Switch 49 previously set to FS ALL.)
- ❽ FS settings are retained in the transmitter memory circuit and transmitted automatically every 60 seconds (Monitor Lamp A goes out momentarily during data transmission.) Therefore, resetting before each flight is unnecessary even though the receiver switch has been turned OFF.
- ❾ After FS settings have been made, always set Function Select Switch 49 to OFF to prevent erroneous settings.
- ❿ To clear all FS settings, set Switch 48 to Position 1, then press buttons 46 and 47 simultaneously.

### FS/HOLD CAN BE CONFIRMED BY MONITOR LAMP.

25

- Function status can be confirmed by means of Monitor Lamp A.  
When Function Select Switch 49 is at FS SELECT: Lamp A ON = HOLD  
Lamp A; OFF = FS
- When Switch 49 is set to FS ALL, Lamp A is OFF.
- When Switch 49 is set to ATV and Button 46 or 47 is pressed. Lamp A, blinks.

## •BFS (BATTERY FAIL SAFE) AND BFS MEMORY

- BFS (Battery Fail Safe) is a warning function which moves only the throttle servo to the same position as set for FS when there is only a small amount of power left in the receiver Nicd batteries. (If no FS position is set, the throttle servo is moved to medium slow.)
- When BFS occurs, the throttle servo can be released and throttle control regained for 36 seconds by lowering the throttle lever to IDLE.
- The throttle stick position at which throttle control is regained is programmable. This is known as BFS Memory and is set as follows:
  - ❶ Set Function Select Switch 49 to BFS MEMO SET and set Channel Select Switch 48 to Pos. 3 (Throttle).
  - ❷ Set the Throttle stick to the desired release point (between Slow and Medium Slow recommended) and press Buttons 46 and 47 simultaneously. BFS Memory is now set.
  - ❸ Set Switches 48 and 49 to OFF.
  - ❹ Whenever BFS occurs in flight, lower the throttle stick to regain control and immediately land the aircraft.

## •SERVO TEST FUNCTIONS

- The operation of the servos can be checked by setting the transmitter and receiver power switches to ON.
- When switch 49 is switched to TEST-A, the servos move half-side first and then, come back to neutral and repeat the other-half from channel 1 to channel 8. (Channel select switch (R) 48 to TEST-ALL position at this time.) The servos set by the channel select switch do not operate. (If set to 5, the landing gear servo does not operate.)
- When switch 49 is switch to TEST-B, all the servos operate linearly over their full travel. (Channel select switch R 48 in TEST-ALL position at this time.) Only the servos set at the channel select switch are operated.

- The servo test is started by pressing button [46]] and is stopped by pressing button 47.

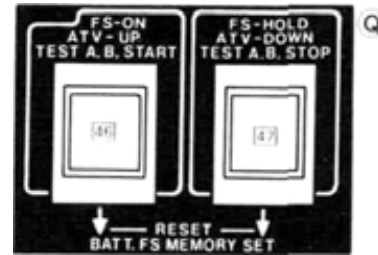

Fig. 48

In this case, set switch [31] to the AUTO ACT position. Rudder dual rate is then automatically turned on and off with the throttle stick. Adjust the throttle stick rudder auto dual rate ON and OFF positions with trimmer [8].

VTR operation is the same as that for aileron dual rate and elevator dual rate. Used it as desired.

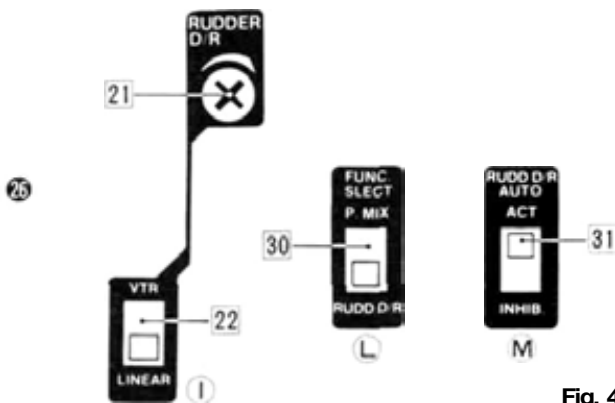

Fig. 49

## •AIRCRAFT WITH VARIABLE PITCH PROP

### ADVANTAGES OF VARIABLE PITCH PROPELLER

The variable pitch propeller offers such advantages as:

1. The desired speed and pull can be adjusted.
2. Speed matched to the engine is obtained.
3. Low noise.
4. Air braking effect by zero pitch.
5. Idling is unnecessary.

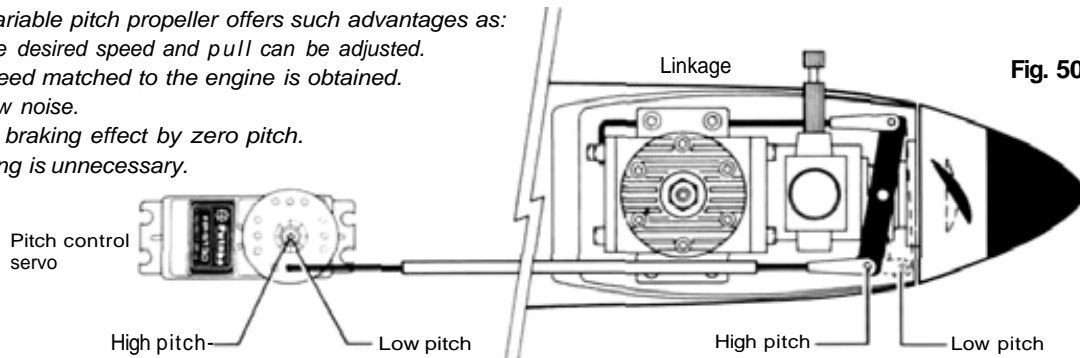

Fig. 50

Matching of the variable pitch propeller to the digital proportional RC set is essential. Improper use is extremely dangerous. Therefore, read this section carefully.

Connect the pitch control servo to channel 8. A variable pitch propeller can be adequately controlled by a common servo. Handle the servo the same as any other servo.

Install the servo and linkage as specified by the manufacturer. (Note) This section explains how to use a MK variable pitch propeller.

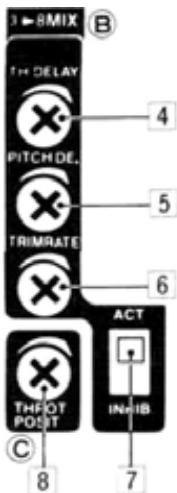

Fig. 51

Set switch [7] to the ACT position. Turn trimmers [4] and [5] fully counterclockwise.

Since trimmer 6 is adjusted after making a test flight, set it to about the center.

Switch II is the mixing ON-OFF switch. When it is set to the OFF position, monitor lamp 22 B comes on. When it is set to the ON position, the lamp goes out. Set the switch to the ON position and check the pitch control (channel 8) servo stroke and direction. Set the servo so the propeller is pitched when the throttle stick is set to HIGH and is zero pitch when the throttle stick is set to LOW. If the servo turns in the wrong direction, reverse the setting of servo reversing switch 57 .

Next, adjust the servo stroke. First set the transmitter pitch control lever 8 to the HIGH position. Then adjust the pitch control servo stroke with the ATV trimmers 48 and 49 so a load is not applied to the linkage. Set the mixing throttle position is 1 stop from the SLOW position (Fig. 52) with the THROT POSIT trimmer [8], and check if:

\* The pitch is zero (minimum) when the throttle lever is set to minimum slow.

\* The pitch becomes 11 (maximum) when the throttle lever is raised one stop.

Next, adjust the transmitter upper side pitch control HIGH side trim lever 8 throw. Set the throttle lever to the HIGH side before making this adjustment. Since lever 8 should be linked with pitch 11 (maximum) the propeller pitch when this lever is set to the lowest position must be checked. A variable pitch propeller is difficult to measure with a pitch gauge. Therefore, adjust trimmer [6] for a pitch somewhat lower than the maximum pitch 11 .

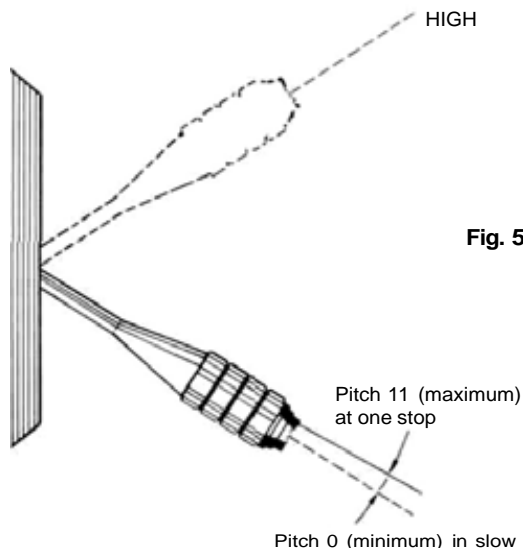

Fig. 52

## ADJUSTMENTS AND FLIGHT TECHNIQUES

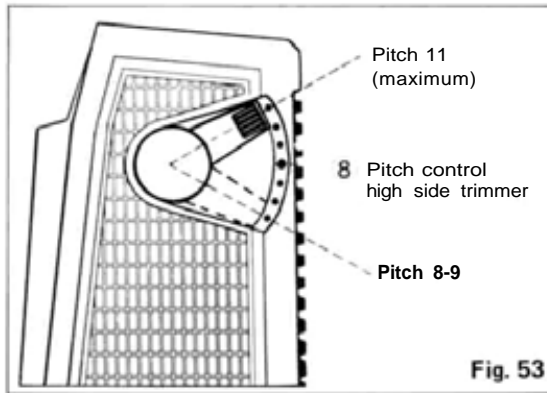

Fig. 53

**NOTE:**

When lowering lever 8, be careful that the pitch does not go negative. This is adjusted during flight. For example, flight is affected by the temperature, air pressure, wind, and other conditions. Use this lever adjusting the speed, pull, etc. to your liking. Also select the engine tone quality by adjusting the propeller pitch. Make quiet flights by fine adjusting the propeller pitch.

Next, adjust the throttle. First, set switch II to the OFF position. Adjust the engine idling speed to 2,200~2,500 rpm with the throttle trim lever 19. Then set switch II to the ON position and set the throttle lever to the maximum slow (zero pitch) position. Adjust idle up lever 9 for an engine speed of 3000 ~ 4000 rpm. Lever 9 is inoperative when switch II is in the OFF position. Use the variable pitch propeller as an air brake during dives.

Pitch zero does not have an air braking affect. If the engine is running at a speed of 3000 ~ 4000 rpm, the air braking effect will not appear if the propeller diameter is too small.

Adjust the throttle so the pitch is positive and the engine idles when switch II is set to the **OFF** position. Since lever 8 is also operative in this state, optimum pitch adjustment is possible.

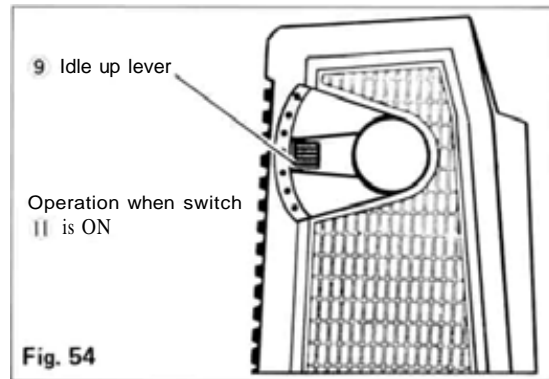

Fig. 54

**NOTES:**

- The pitch always becomes maximum when the throttle switch is set to HIGH.
- The speed cannot be increased with the idle up lever 9 when the propeller pitch is zero.
- Since the air braking effect is higher than normal when landing at zero propeller pitch, be careful until you become familiar with the setting.
- Best result is often obtained by making the tuned pipe longer.

### VARIABLE PITCH PROPELLER AND ENGINE POWER MATCHING IS ESSENTIAL FOR MAXIMUM PERFORMANCE

If the throttle stick is operated quickly during flight, the engine will make an abnormal sound (sputter). If the engine sound remains unnatural, the pitch control or throttle servo operation timing can be delayed.

When the throttle lever is suddenly moved from a high speed to a low speed, the throttle operates before the propeller pitch changes to zero. If the throttle lever is moved from HIGH to SLOW, the pitch will change before the throttle operates.

Set the throttle delay time with trimmer [4] and the pitch delay time with trimmer [5]. This provides the same feeling as fixed propeller aircraft and allows natural flight.

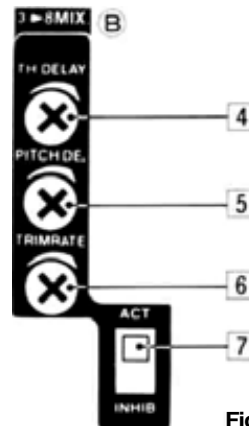
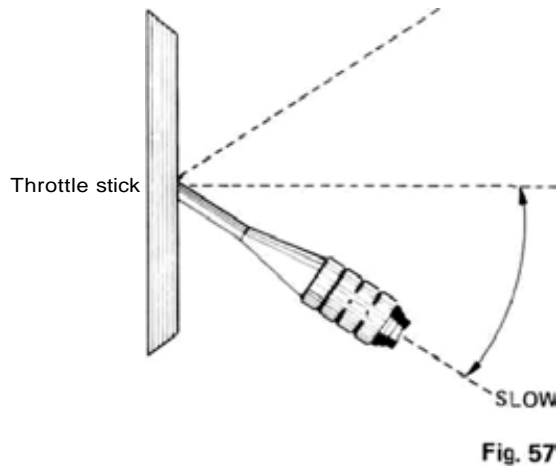
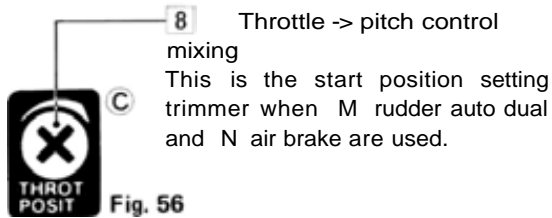

Fig. 55

## •THROTTLE POSITION TRIMMER



- (B) Throttle -> pitch control mixing  
The pitch control servo mixing point can be set to an arbitrary point between throttle lever 3 maximum slow and medium slow. When the throttle lever is moved from SLOW to HIGH, the mixing function is turned on. When the throttle lever is moved from HIGH to SLOW, the mixing function is turned off.  
The start point can be set to the point at which maximum engine torque and propeller air braking affect is displayed. (Normally, set it to within a range of one or two stops from the slowest position.)
- M Rudder auto dual rate  
Rudder dual rate can be automatically turned on and off from any point between the throttle lever 3 maximum slow and medium slow positions. (When M switch is in the ON position.)  
When the throttle lever is moved from SLOW to HIGH, rudder dual rate is turned ON. When the throttle lever is moved from HIGH to SLOW, rudder dual rate is turned off. Rudder dual rate trimmer 21 set the deflection angle when rudder dual rate is on.
- (N) Air brake  
Air brake (flap, spoiler -> elevator, throttle -> flap, spoiler -> elevator) mixing can be set to any point between the throttle lever 3 maximum slow and medium slow positions. When the throttle lever is moved from SLOW to HIGH, mixing is turned off. When the throttle lever is moved from HIGH to SLOW, mixing is turned on.

79

## •AIRCRAFT WITH FLAPS

Connect the flap servo to channel 6 of the receiver.

- Flaps are normally controlled by the CH6 Knob 6 on the transmitter front. Wide or narrow (Flap Trim) travel may be selected by Flap Switch 18 on the trimmer panel.

'Wide throw is often best for normal landing flaps and airbrake operations.

Narrow (Trim) throw allows Flaps or Flprons (see page 31 ) to be used for pitch trim adjustments in knife edge and vertical maneuvers. Narrow throw may also may also be best for Elevator -> Flap (2 -> 6) mixing.

## •ELEVATOR/FLAP MIXING

### ELEVATOR -> FLAP MIXING

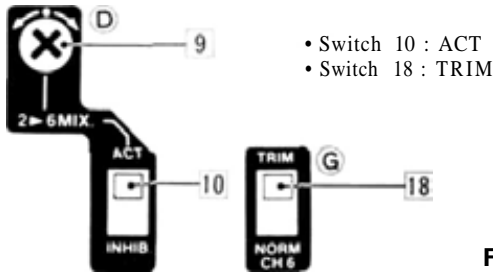

Fig. 58

• Elevator -> Flap (2 -> 6) mixing is unidirectional with elevator (CH2) acting as the Master channel. This function can be helpful in looping, square cornered, and circular acrobatic maneuvers. Set up the function as follows:

- 1 Set Safety Switch 10 to ACT and Flap Switch 18 to TRIM.
- 2 Set Control Switch 12 to ON and adjust Trimmer [9] to give DOWN flaps with UP elevator stick movement. Initially, set deflection angles so that the flap down angle is approximately the same as the elevator up angle.
- 3 Transmitter Control Switch 12 is used to turn this function ON and OFF in flight as desired.

### FLIGHT ADJUSTMENT

- 1 Make a test flight with Switch 12 OFF and adjust the Elevator trim and deflection to suit.

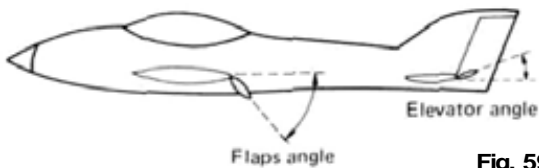

Fig. 59

- 2 Turn Switch 12 ON and test control response. If the response is not correct, turn switch 12 OFF, land and adjust flap deflection with Trimmer 9 .
- 3 Most common maneuvers can be performed with the mixing function ON. Rolls and spins may be better without the mixing depending on the aircraft. Mixing is generally not recommended for landing.

## •FLAP/ELEVATOR MIXING (PRE-SET FLAPS AND ELEV. TRIM)

### FLAP -> ELEVATOR MIXING (ELEVATOR DOWN MIXING) ADJUSTMENT

• This is a pre-set or switch-activated type of mixing and is ideal for landing approaches with stunt and scale aircraft. An airbrake effect is produced which is very realistic and makes short field landings easier.

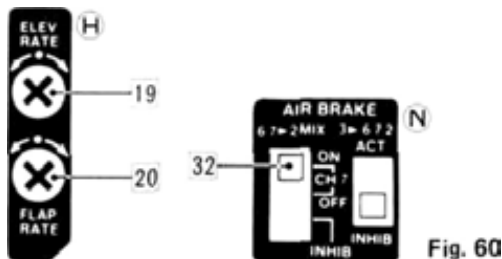

Fig. 60

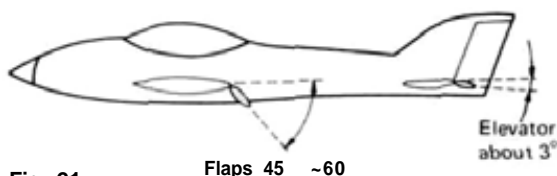

Fig. 61

- 1 Set Airbrake Switch 32 (6, 7 -> 2 MIX) to ON. Monitor Lamp (C) comes ON. Control Switch 10 can be used to turn the function ON and OFF in flight. When Switch 10 is ON, Lamp C Blinks.
- 2 Turn Switch 10 ON and set Flap Knob 6 to Zero. Lower the flaps 45 to 60 degrees using Trimmer 20 and set the Elevators about 3 degrees down using Trimmer 19. NOTE: These settings are estimates and will vary depending on elevator and flap areas, etc.
- 3 Set Switch 10 to OFF for takeoff. When at a safe altitude, reduce the throttle to medium slow and after the aircraft has slowed somewhat, turn Switch 10 to ON. The aircraft should maintain level flight. If the aircraft climbs or dives, set Switch 10 to OFF, land, and readjust the elevator angle as necessary with Trimmer 19 . Remember, do NOT try to adjust back panel trimmers while in Flight. Make adjustments in small steps.
- 4 Flap Neutral position can be changed in flight using the Flap Knob 6 . This applies whether mixing is ON or OFF.



## •AIRCRAFT WITH FLAPS AND SPOILERS(AIRBRAKE)

- 1 Connect the Flap servo to CH6 and the Spoiler servo to CH7 on the Receiver. Set Switch [32] to ON.

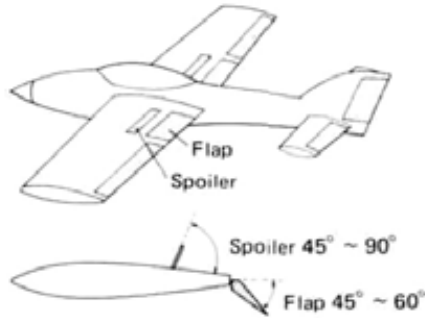
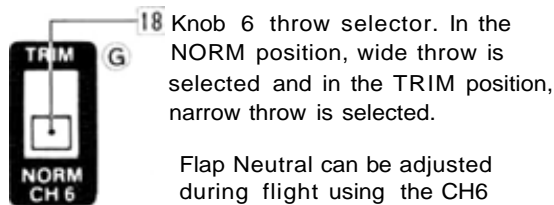

Fig. 62

- 2 Set Control Switch 10 to ON and adjust the flaps as shown in Fig. 62 with Trimmer 20. Adjust the spoiler servo travel with Memory ATV Trimmers [46] and [47]. (See Page 17)
- 3 When used in this manner, flaps and spoilers will be deployed simultaneously to the pre-set positions when Switch 10 is set to ON. This acts as an airbrake. NOTE: In this mode, the Spoiler Knob 7 will be inoperative and its function transferred to Switch 10. Alternatively, Switch 32 can be set to CH7 OFF and Knob 7 used for spoiler control.
- 4 Elevator Trimmer 19 can be adjusted if necessary so that the aircraft maintains level flight with the airbrake deployed.

## •FLAP TRIM FUNCTION

### FLAP TRIM



Knob 6 throw selector. In the NORM position, wide throw is selected and in the TRIM position, narrow throw is selected.

Flap Neutral can be adjusted during flight using the CH6 Flap Knob 6.

- This is helpful in making pitch axis trim adjustments for knife edge and vertical maneuvers.
- This function can be used whether Mixing Switches 10 and 12 are ON or OFF.

- Flap Switch 18 on the trimmer panel can be set to TRIM position to provide a finer adjustment if desired. (This may not be possible however, if wider angles are needed for other flap functions.)

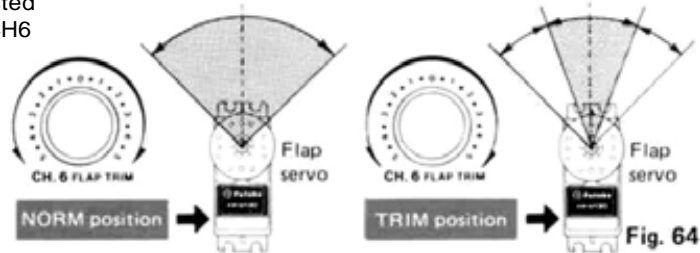

31

### AUTOMATIC AIR BRAKING (THROTTLE STICK OPERATION)

- This feature permits automatic deployment of the airbrake (flaps and elevator or flaps, spoilers, and elevator) as the throttle stick is lowered.

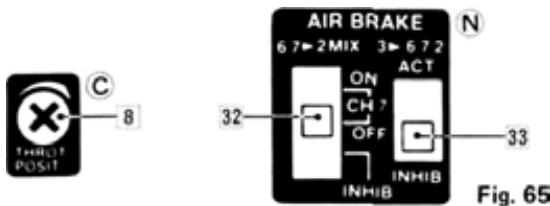

Fig. 65

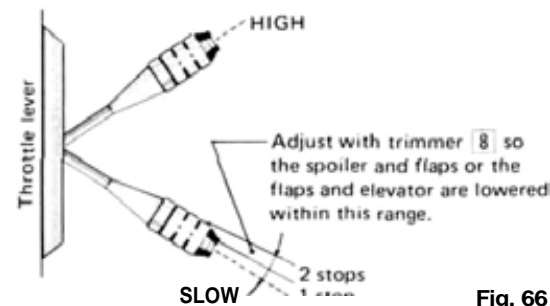

Fig. 66

When the throttle is again moved to HIGH, the airbrakes are retracted automatically. Operation in this manner is very efficient as it allows the use of the airbrake function while leaving the pilot free to concentrate on the primary controls.

- 1 Set Switch [32] to INHIB and Switch [33] to ACT. Monitor Lamp B comes on.
- 2 Set Control Switch 11 to ON. Lamp B blinks.
- 3 Trimmer 8 is used to set the throttle stick position at which the airbrake is deployed. Deployment at one or two stops from the maximum Slow position is usually the most suitable.
- 4 The Auto Airbrake function can be turned ON and OFF in flight by using Control Switch II.
- The Automatic Air Brake Function is very useful for slowing the aircraft during maneuvers and landing approaches. When executing a "go around" for a missed approach, the airbrake will be immediately released as the throttle is moved to HIGH.

## •SNAP ROLL SWITCH (TIMER IS OPTIONAL)

•When this function is used, snap rolls can be performed by pushing the Snap Switch 13. Snap roll directions can be set using Control Switches 34 and 35.

- 1 Set Safety Switch 29 on the trimmer panel to ACT. Monitor Lamp D will blink.
- 2 A snap roll in the direction set by switches 34 and 35 can now be performed by pushing Control Switch 13 to ON. The aircraft will continue to roll as long as the switch is held ON unless the optional timer function is installed.
- 3 The optional timer function can be used to automatically stop the snap roll. Trimmers (25), [26], [27], and [28] can be used to set the time in each direction. The time can be varied from 0.2 to 2 seconds.

NOTE: The Snap Switch 13 is positioned so that it is easy to reach. When the snap roll function is activated, you must use great care not to push the switch inadvertently. When the snap roll function is not desired, always set Safety Switch [29] to INHIB.

### SNAP ROLL TIMER (OPTION)

These are the snap roll time setting trimmers and snap roll function safety switches.

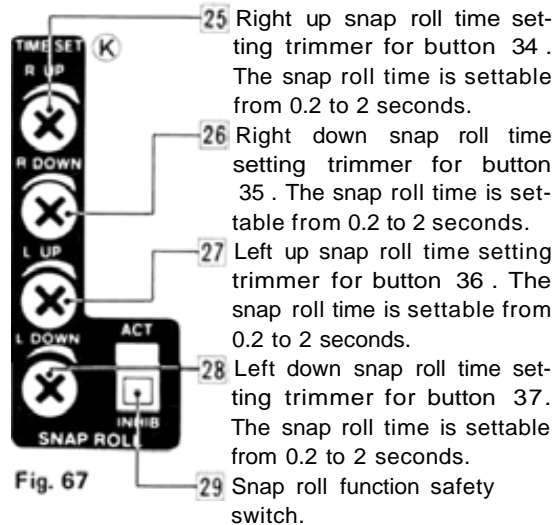

32

## •PROGRAMMABLE MIXING AND EXAMPLES

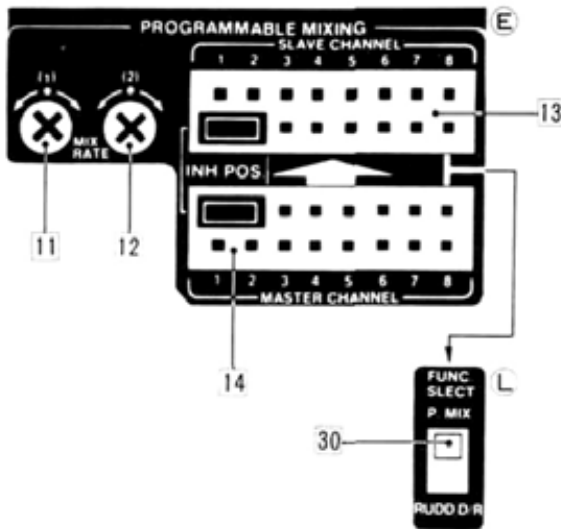

- Programmable mixing of any two channels desired is possible using the mixing board on the trimmer panel. Programmable mixing is NOT a memory function and all programmed mixing is of the unidirectional type.
- The Master and Slave channels can be designated using Jumper Connectors 13 and 14. The mixing amount in each direction of servo movement is adjustable using Trimmers 11 and 12.
- When Programmed Mixing is not in use. Connectors 13 and 14 should be placed in the INHIB position as shown in Fig. 68.
- When Function Select Switch 30 is set to P. MIX, programmed mixing can be switched ON and OFF in flight using Control Switch 16. When Switch 30 is set to RUDD D/R, programmed mixing will remain ON if activated using Connectors 13 and 14, and Control Switch 16; can be used to turn the Rudder Dual Rate function ON and OFF.

# ADJUSTMENTS AND FLIGHT TECHNIQUES

## EXAMPLE 1. Fig. 69. AILERON -> RUDDER MIXING

- This function is sometimes referred to as "CAR" (Coupled Ailerons and Rudder) and is useful on sailplanes and certain scale models where aileron and rudder must be used together for coordinated turns.

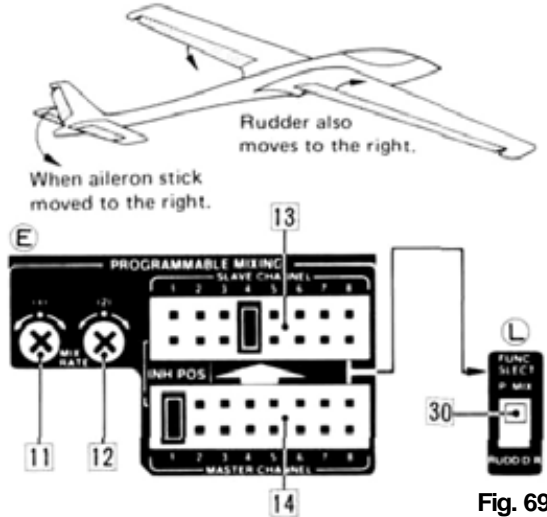

- 1 Connector 4 designates the Master channel and is set vertically at the CH1 (Aileron) position.
- 2 Connector 13 designates the Slave channel and is set vertically at the CH4 (Rudder) position.
- 3 Set Switch 30 to P. MIX if it is desired to turn the mix function ON and OFF in flight. Otherwise, it will remain ON and Control Switch 16 is available for use as the Rudder Dual Rate ON/OFF Switch.  
NOTE: If Switch 16 is used as the P. MIX ON/OFF Switch, Rudder Dual Rate cannot be switched manually, but Auto Dual Rate Rudder can still be used.
- 4 Use Trimmers 11 and 12 to set the amount and direction of desired Rudder movement when the Aileron stick is deflected.

## EXAMPLE 2. Fig. 70.

- Programmed Mixing can be used to correct an unwanted UP or DOWN pitch movement of the aircraft when Rudder is during knife edge and rolling maneuvers.

- 1 Set the Mixing Board as shown in Fig. 70 to provide mixing from Rudder -> Elevator.
- 2 Use Trimmers 11 and 12 to adjust the desired amount and direction of Elevator compensation when Rudder is applied in both Left and Right directions.

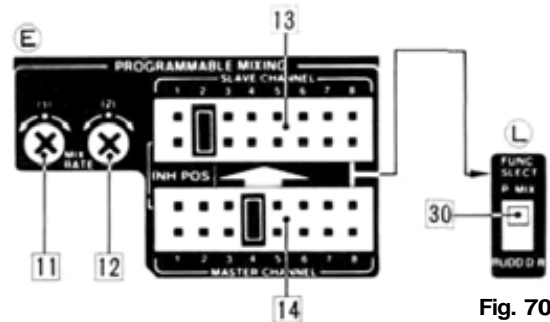

## EXAMPLES. Fig.71.

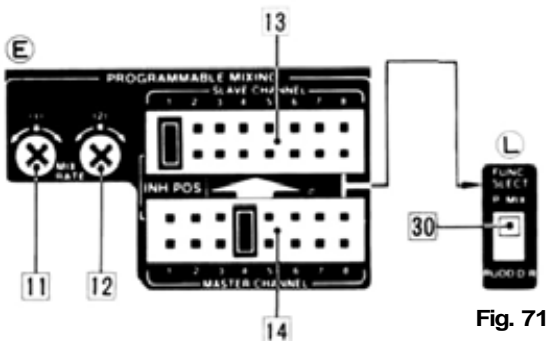

- Certain aircraft such as scale models with large dihedral or stunt aircraft with incorrect dihedral may exhibit an unwanted rolling tendency when Rudder is applied (as opposed to a pure Yaw motion). This can cause variations in the roll rate during slow rolls and/or a "roll out" tendency during point rolls and knife edge maneuvers. This can be corrected with Programmed Mixing.

- 1 Set the mixing panel as in Fig. 71 to provide mixing from Rudder to Aileron.
- 2 Trimmers 11 and 12 can be adjusted so that a small amount of corrective Aileron is automatically applied with Rudder movement. Both directions of Rudder movement can be adjusted for.

## EXAMPLE 4.

- An unwanted Left or Right Yaw tendency during pull ups can be adjusted by setting the mixing panel for Elevator to Rudder mixing (Elevator CH2 is the Master channel).

## •MUTUAL (BI-DIRECTIONAL) MIXING (FLPRON, ELEVN, V-TAIL, DIFF)

Aileron + flap (FLPRON), aileron + elevator (ELEVN), rudder + elevator (V.TAIL), and aileron differential (DIF) mixing can be selected with a switch.

### FLPRON (AILERON + FLAP)

- This function allows the use of flaps on aircraft with full length "strip" ailerons.
- Use a separate servo on each aileron and connect as shown in Fig. 61 . NOTE: Always connect the servo on the Right Aileron to CH1 (Aileron). The Left servo to CH6 (Flap).
- Set Switches 16 and 17 as shown in Fig. 72.
- Aileron differential can be varied to suit using Trimmer 15 . Trimmer 15 will vary the amount of DOWN travel available on each aileron. UP movement is not affected.

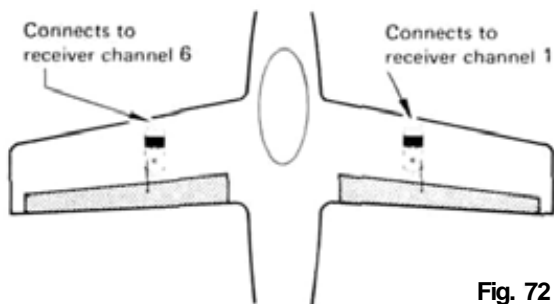

Fig. 72

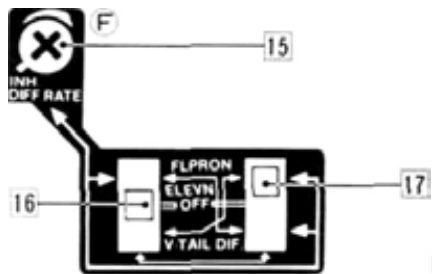

Fig. 73

- The Flap function can be operated by using the Flap Knob 6 or better by using Switch 10 to activate the Flaps and Elevator trim if necessary (See Flap -> Elevator Down mixing Page 30).
- Elevator -> Flap mixing is possible by setting trimmer panel Switch 10 to ACT and Control Switch 12 to ON. (See Elevator -> Flap mixing Page 30)
- Pitch trim in vertical maneuvers and point maneuvers can be adjusted easily by using the Flap Knob 6 .
- NOTE: When the ailerons are operated while in the Flap DOWN mode, an additional downward movement of the Aileron occurs. Wing tip stall can occur easily if the Aileron is down too far. To prevent this, it may be necessary to use the aileron differential (Trimmer 15) to reduce the downward travel.

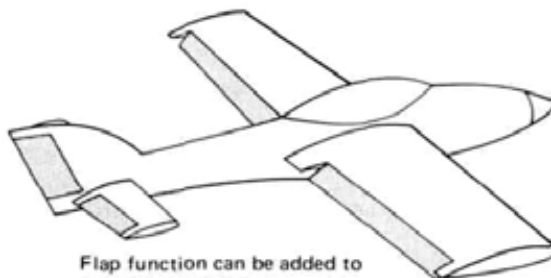

Fig. 74

- \* Always connect the servo at the right wing to receiver channel 1 (aileron).

# ADJUSTMENTS AND FLIGHT TECHNIQUES

## ELEVN (AILERON + ELEVATOR)

- This type of mixing can be used with tailless and delta wing aircraft and flying discs.
- Install and connect the servos as shown in Fig. 75. Always connect the Right side servo to CH1 (Aileron).
- Aileron differential can be adjusted with Trimmer 15.

Connect to-  
channel 2  
(elevator).

-Connect to  
channel 1  
(aileron).

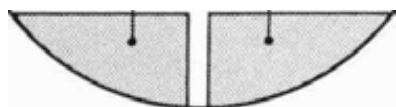

Fig. 75

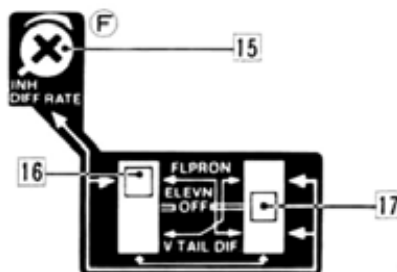

Fig. 76

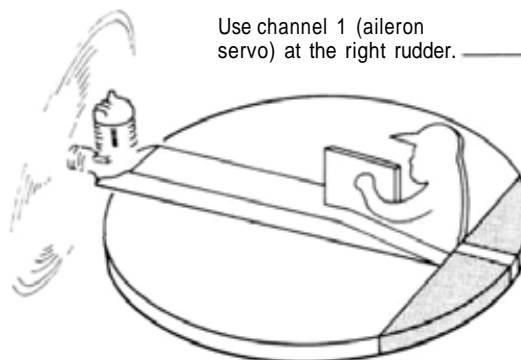

Fig. 77

## V.TAIL (ELEVATOR + RUDDER)

- This mixing is used for gliders, scale model Bonanzas, and other V-Tail aircraft.
- Install and connect the servos as shown in Fig. 78. Always connect the servo to the Right Rud-dervator to CH2 (Elevator).
- Set Switches 16 and 17 as shown in Fig. 79.

Connect to  
channel 4 (rudder)

Connect to  
channel 2 (elevator).

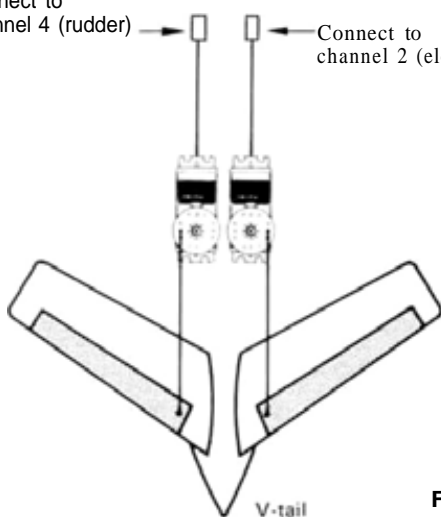

Fig. 78

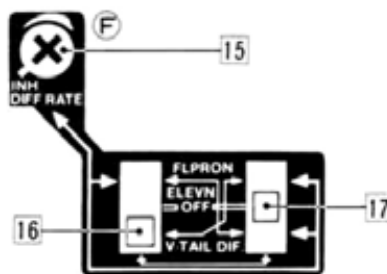

Fig. 79

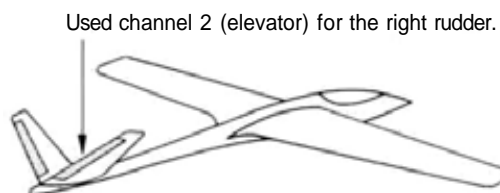

Fig. 80

\* When connecting the linkage, connect channel 2 (aileron servo) to the right wing rudder.

